

# BORGOO

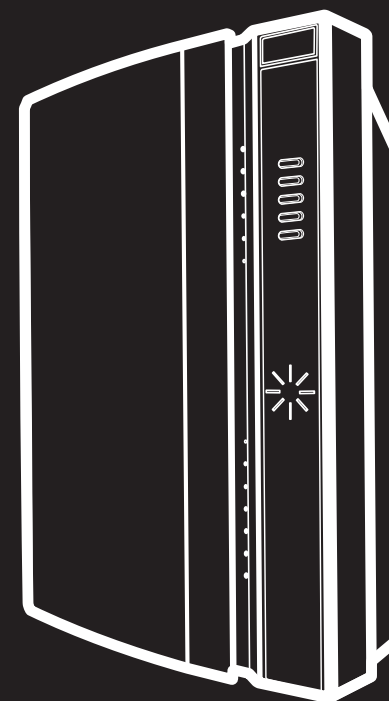

## 佛山市首冠电器有限公司

地址：广东省佛山市南海区里水镇邓岗北牌村西门工业区北面1号厂房  
香港办公地址：香港长沙湾长裕街10号利行工业大厦1楼108室

Foshan Shouguan Electrics Co., Ltd.

ADD : No.1 North, Ximen Industrial Zone, Beiyu village, Denggang, Lishui town, Nanhai District, Foshan City, Guangdong Province, China

HK ADD : Unit108,1/F, Lee Hang Industrial Building, 10 Cheung Yue Street, Cheung Sha Wan, Kowloon, HK

TEL : 86-0757-85606277 85613883

FAX : 86-0757-85613883

[www.borgoo.com](http://www.borgoo.com)

佛山市首冠电器有限公司保留更改产品设计与规格的权利，如有变动，恕不另行通知

## 空气净化器 BA-1000

## 使用说明书

## 目录

|    |        |
|----|--------|
| 2  | 产品简介   |
| 2  | 产品特点   |
| 3  | 构件说明   |
| 4  | 注意事项   |
| 5  | 操作指南   |
| 11 | 清洁及保养  |
| 13 | 疑难解答   |
| 14 | 技术规格参数 |
| 14 | 执行标准   |
| 15 | 英文版说明书 |

## 产品简介

感谢您的选择，欢迎光临博格利佳。BA-1000 室内空气净化器，是采用香港科技大学全球独家专利研发的“NCCO”——纳米催化氧化技术的专业空气净化产品。能快速净化室内空气，让您随时仿若置身天然氧吧。为了获得至佳效果，请将该高效能空气净化器放置在您停留时间最长的处所，如客厅或卧室。

室内的污染物主要包含：甲醛、苯系物、氨、氡、挥发性有机化合物和浮尘，其主要来源于建筑材料、室内装修、装饰物和动植物等。长期接触，可导致慢性呼吸道疾病，妊娠综合症，引起新生儿体质降低，染色体异常，甚至引起鼻咽癌。

本产品所采用的“NCCO”——纳米催化氧化技术，结合了5层过滤，包括HEPA过滤网，其净化效果大大优于仅仅只有HEPA过滤网的传统净化器。能有效分解甲醛、苯系物、氨、氡等污染物，并过滤浮尘。其主要功能如下：

- 1、消毒、除异味
- 2、消除病毒、细菌、真菌
- 3、过滤空气中的尘埃、花粉、悬浮粒子
- 4、分解所有的挥发性有机化合物TVOC转换成无害物质

## 产品特点

- 1、国际专利NCCO纳米催化式氧化技术，5重极度净化，呵护全家健康
- 2、过滤尘埃、杀菌灭毒、去除异味、降解气体样样拿手，快速改善室内空气质量。
- 3、超静音设计，优享生活，犹如置身大自然
- 4、智能化设计，耗电率低，全天净化不足一度电，节能更环保
- 5、12小时定时预约功能，人性化设计，方便使用
- 6、LCD液晶显示屏动态显示运行状态，彰显豪华
- 7、超长纳米滤芯使用寿命，无需频繁更换，节省花费
- 8、智能使用寿命提示系统，准确提示HEPA滤网及纳米滤芯更换需要
- 9、前置过滤网可拆卸水洗，清洁、保养更方便
- 10、前盖特设安全装置，更有正确安装提示，贴心设计，更显人性化
- 11、三档风速调节，另特设极速档位，全面满足生活不同需要
- 12、强劲离心式风扇，输风量大，快速完成空气净化

## 构件说明

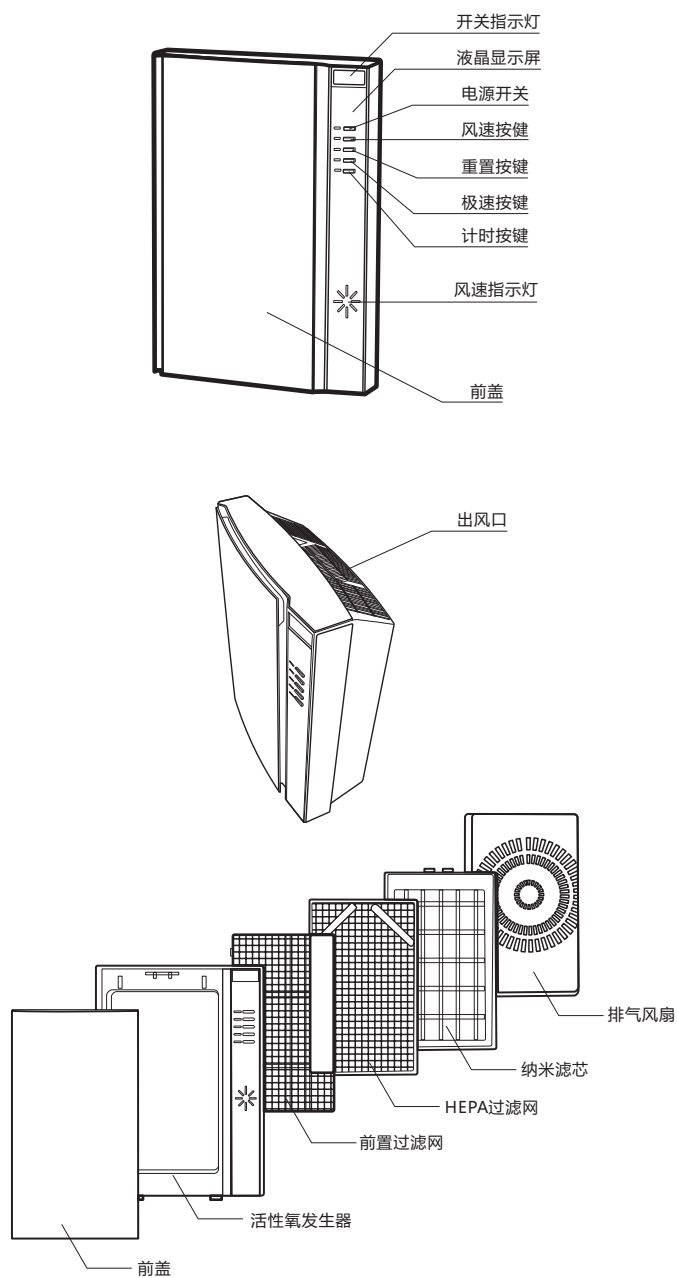

## 注意事项

使用BA-1000 室内空气净化器之前, 请仔细阅读本说明书并妥善保管, 以供日后参考。

## 危险

- 1、切勿让水或任何其它液体或易燃性清洁剂进入产品, 以免发生触电和(或)火灾。
- 2、切勿用水或任何其它液体或(易燃性)清洁剂来清洁产品, 以免发生触电和(或)火灾。

## 警告

- 1、在将产品接通电源以前, 首先确认产品底部所标示的电压是否与当地的电压相符。否则可能导致产品损坏。
- 2、请保持电源线完好。电源线请勿割伤、损坏、过度弯曲、拉扯、扭转、打结、或靠近高温处。并请勿压上重物、挤压、或重新自行组装。否则, 电源线损伤, 会导致短路、着火。
- 3、电源线、插头损伤时或插座松动时, 请勿使用。否则, 会有造成触电、短路、起火的危险。
- 4、请勿让肢体不健全、感觉或精神上有障碍或缺乏相关经验和知识的人(包括儿童)单独接触或使用本产品。否则会有触电危险。
- 5、请勿用湿的手插拔电源插头。否则, 会有触电、受伤的危险。
- 6、请勿堵塞进风或出风口, 否则会大大降低产品净化效果, 甚至导致产品受损。

## 注意

- 1、本产品专为家庭和办公室所设计, 请勿在灰尘或油烟过多的环境使用, 以免损害及缩短过滤网寿命。
- 2、请在干燥、稳固、平整且水平的表面上放置和使用本产品。避免发生意外。
- 3、产品的后侧及两侧均要留出至少 20 厘米的空间, 产品上方至少要留出 30 厘米的空间。
- 4、切勿在产品顶部放置任何物品, 也不要坐在产品上, 以免产品受损。
- 5、切勿将产品直接放在空调下方, 以防冷凝水滴到产品中。以免产品受损。

- 6、本产品配备安全装置，如果过滤系统安装不正确，产品将无法启动。
- 7、只能使用博格专门为本产品设计的原装过滤网，切勿使用任何其它过滤网。否则产品无法运作，甚至导致产品受损。
- 9、请勿用硬物敲击本产品，以免产品受损。
- 10、请始终用产品背面的手柄提拉或移动产品。以免导致产品受损。
- 11、请勿用手指或者异物插入进气口和出风口。否则可能导致产品受损，甚至触电危险。
- 12、请勿坐在本机上或依靠在本机上，以免发生身体受伤或损害本机。
- 13、当您使用室内喷雾式驱虫剂或在充满易燃气体的地方时，请勿使用本产品。否则可能导致火灾危险。
- 14、请勿在气体用具、加热装置或火炉附近使用本产品。否则可能导致产品受损，甚至起火。
- 15、请将本产品放在距离发出电波的设备至少2米的位置，放置电波对其产生干扰。
- 16、在使用暖气的同时，请保持空气流通，避免一氧化碳产生。
- 17、使用之后和清洁产品前，务必先将电源插头拔掉。以避免触电危险。
- 18、请勿擅自拆卸或维修产品。为避免危害，产品需要维修时，请咨询博格客户服务中心，由制造厂或指定维修中心维修。

## 操作指南

### 首次使用:

- 1、清点随机附件和资料，仔细阅读使用说明书并保存以备日后查阅。
- 2、移除所有包装，用柔软干布清洁所有可拆解部件、产品内腔后，将其组装好。（请参考清洁、安装及拆卸指南）。
- 3、把产品放在干燥、稳固、平整且水平的平面上，确保产品的后侧及两侧均要留出至少 20 厘米的空间，产品上方至少要留出 30 厘米的空间。
- 4、检测电源、插座等，确认符合产品“使用说明书”的要求，然后插入插座。产品便可开始正常使用。

### 部件拆卸方法：

安装时请按拆卸方法的相反顺序进行。

- 1、请确保产品在关闭状态，并已拔出电源。

- 2、抓住前盖顶部，向前拉开前盖扣，再向上取出前盖。

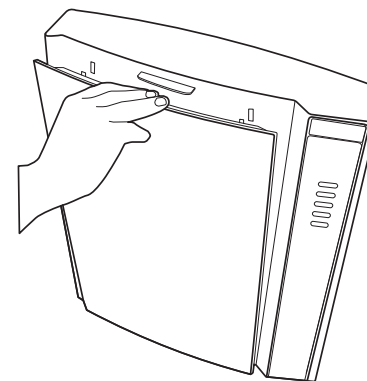

- 3、捏住过滤系统突出部位并向下压，将整个过滤系统取出。

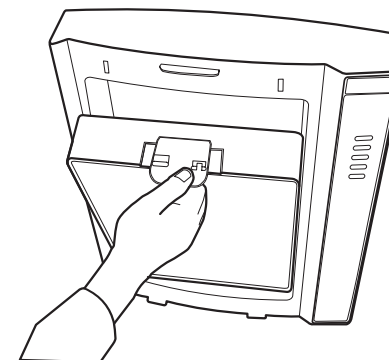

4. 捏住前置过滤网突出部位，轻轻将前置过滤网取出。

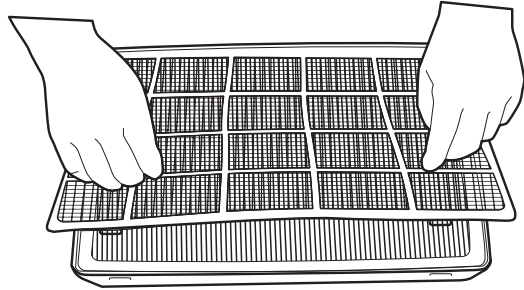

5. 轻提HEPA过滤网两侧拉带，将HEPA滤网取出。

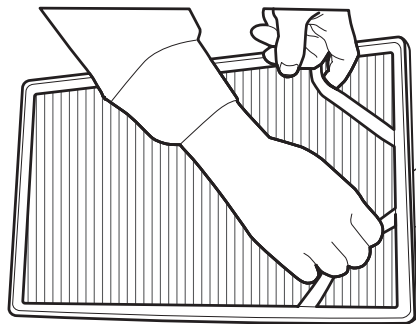

### 部件组装方法：

1. 抓住HEPA过滤网两侧拉带，将滤网装入纳米滤芯组件的凹槽中。

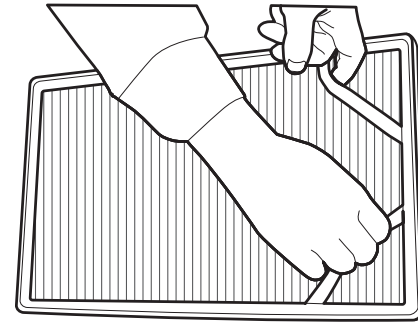

2. 捏住前置过滤网边缘，将滤网边缘的突出部位对准过滤系统侧边的插孔，再弯曲另一侧，将前置过滤网完全装入。

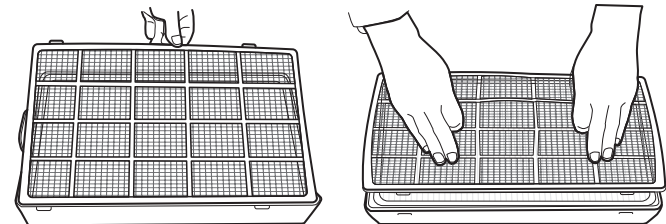

3. 将组装好的过滤系统装入机身。

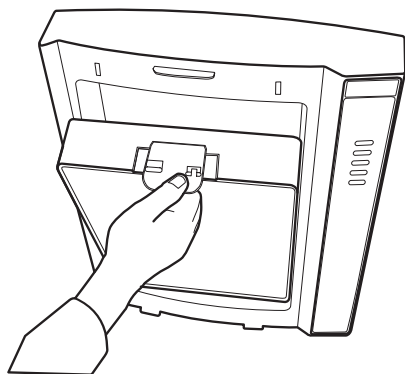

4. 将前盖底部卡扣对准机身卡扣座，然后轻推前盖顶端将前盖固定住。

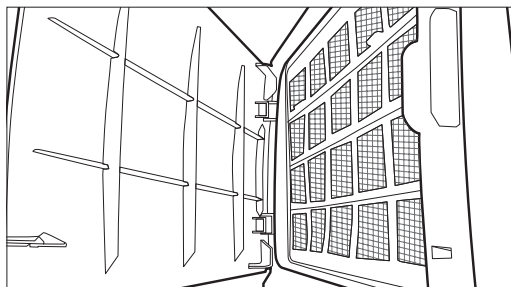

## 使用方法

### 待机模式

- 1、连接电源后产品所有按键指示灯都会亮，产品处于待机状态。如果在30秒内没有按下任何按键，所有指示灯将会自动关闭。
- 2、如需继续操作，请按下最上端“POWER”开关按键，指示灯亮，产品开始运作。

### 如何开关机

- 1、连接电源后，按下“POWER”开关按键，以启动空气净化器。
- 2、右上方的红色指示灯亮，表示产品开始运作。5分钟后指示灯转为绿色，表示产品运作正常。
- 3、开机后马达的转速默认为中档，液晶显示屏显示为“L2”。
- 4、如果过滤系统安装有误，按下“POWER”开关按键后，液晶显示屏将会显示“Er”，表示安装有误，需要重新安装。
- 5、需要关机时，按下“POWER”开关按键，产品停止工作。

### 如何设置风速

- 1、开机模式下按下“SPEED”风速按键，调整马达转速，设定风速。
- 2、液晶显示屏显示“L1”：马达转速为低档
- 3、液晶显示屏显示“L2”：马达转速为中档
- 4、液晶显示屏显示“L3”：马达转速为高档

### 重置功能

开机模式下按下“RESET”重置按键，取消HEPA过滤网和纳米滤芯更换提示功能，同时清除风速、极速净化、时间设置。产品回到默认设定：液晶显示屏显示“L2”，马达转速为中档。

### 设置活性氧

- 1、开机模式下按下“TURBO”极速按键，活性氧发生器开始运作，液晶显示屏显示“AU”。
- 2、活性氧发生器运作60秒后，将自动恢复到默认设定：液晶显示屏显示“L2”，马达转速为中档。
- 3、如需让活性氧发生器继续运作，请再次按下“TURBO”极速按键。
- 4、当您想在短时间内达到快速净化的时候可以开启此功能。

## 时间设置

开机模式下,按下“TIMER”计时按键,可选择1到12小时的运作时间,并开始倒计时。当倒计时到零时,产品将自动关机。

## 智能提示功能

- 1、当HEPA过滤网上吸附过多灰尘时,最上端的开关指示灯将会一直红灯闪烁并发出“哔哔”两声,提示您更换新的HEPA滤网。一般情况下HEPA过滤网的使用寿命可达18个月。
- 2、当纳米滤芯需要更换时,最上端的开关指示灯将会一直红灯闪烁并发出“哔哔哔”三声,提示您更换新的纳米滤芯。由于纳米滤芯自身有循环更新作用,其使用寿命可达4年。

# 清洁及保养

注意:

- 1、切勿将本产品机身浸入水中或任何其它液体中
- 2、切勿使用具有腐蚀性或易燃性的清洁剂(例如漂白剂或酒精)清洁本产品的任何部件。

## 机身的清洁

- 1、清洁空气净化器时,请务必拔出插头,切断电源。
- 2、请使用柔软的干布擦去产品身上的灰尘。
- 3、请使用柔软的干布清洁出、入风口。

## 过滤系统的清洁

- 1、过滤系统由前置过滤网、HEPA过滤网、纳米滤芯组成。过滤系统的使用寿命取决于使用环境的空气污染程度。
- 2、前置过滤网可用水洗,建议每1-3个月清洗一次。
- 3、HEPA过滤网不可水洗,一般情况下HEPA过滤网的使用寿命可达18个月。
- 4、纳米滤芯不可水洗,由于纳米滤芯自身有循环更新作用,其使用寿命可达4年。

## 如何清洗前置过滤网

- 1、清洗前请确保产品在关闭状态,并已拔出电源。
- 2、请按部件拆卸方法1、2、3,卸下前置过滤网。
- 3、请用水清洗或用吸尘器清洁,再将前置过滤网晾干。
- 4、按组装方法2、3、4组合产品。
- 5、按正常程序开机,产品即可如常运作。

## 如何更换HEPA过滤网

当您听到两声“哔哔”响,且最上端的开关指示灯一直红灯闪烁时,请更换新的HEPA滤网。

- 1、更换前请确保产品在关闭状态,并已拔出电源。
- 2、请按部件拆卸方法1、2、3、4,卸下旧HEPA滤网。
- 3、拆除新购置HEPA滤网的外包装。
- 4、按组装方法1、2、3、4组合产品。
- 5、开机后,请按下“RESET”重置按键2秒,重新设置提示功能。产品即可如常运作。

## 如何更换纳米滤芯

当您听到三声“哔哔哔”响,且最上端的开关指示灯一直红灯闪烁时,请更换新的纳米滤芯。建议同时更换HEPA过滤网。

- 1、更换前请确保产品在关闭状态,并已拔出电源。
- 2、请按部件拆卸方法1、2、3、4,卸下旧纳米滤芯。
- 3、拆除新购置纳米滤芯的外包装。
- 4、按组装方法1、2、3、4组合产品。
- 5、开机后,请按下“RESET”重置按键2秒,重新设置提示功能。产品即可如常运作。

## 疑难解答

委托修理前，请仔细阅读该使用说明书后检查以下项目。

|                         |                      |  |
|-------------------------|----------------------|--|
| 按下开关按键后产品不工作            | 请检查电源是否已连接           | 请连接正确电源。                                 |
|                         | 请检查过滤系统是否安装正确        | 请正确安装过滤系统。                               |
|                         | 请检查电源线是否损坏           | 请咨询博格客户服务中心，由制造厂或指定维修中心维修。               |
| 无法过滤灰尘                  | 请检查过滤系统是否安装正确        | 请正确安装过滤系统                                |
|                         | 请检查前置过滤网是否吸附了过多灰尘或毛发 | 请及时清洁前置过滤网                               |
|                         | 请检查HEPA过滤网是否吸附了过多灰尘  | 请检查HEPA过滤网并及时更换，一般情况下其使用寿命可达18个月         |
| 开关指示灯一直红灯闪烁并发出“哔哔”两声    | 提示您更换新的HEPA滤网        | 请检查HEPA过滤网并及时更换，一般情况下其使用寿命可达18个月         |
| 开关指示灯一直红灯闪烁并发出“哔哔哔”三声   | 提示您更换新的纳米滤芯          | 请检查纳米滤芯并及时更换，一般情况下其使用寿命可达4年。建议同时更换HEPA滤网 |
| 更换HEPA滤网和纳米滤芯后开关指示灯仍然闪烁 | 更换后未重置提示功能           | 请按下“RESET”重置按键2秒                         |
| 液晶显示屏出现“Er”，按任何键都无反应    | 过滤网安装错误              | 请重新安装过滤网，并确定滤网正确的卡紧于过滤系统内                |

## 技术规格参数

|      |               |                |                                  |                               |        |
|------|---------------|----------------|----------------------------------|-------------------------------|--------|
| 产品   | 室内空气净化器       |                |                                  |                               |        |
| 型号   | BA-1000       |                |                                  |                               |        |
| 额定电压 | 220V~         |                |                                  |                               |        |
| 额定频率 | 50Hz          |                |                                  |                               |        |
| 使用面积 | 46平方米         |                |                                  |                               |        |
| 产品尺寸 | 419*210*574mm |                |                                  |                               |        |
| 产品净重 | 9.5KG         |                |                                  |                               |        |
| 额定功率 | 55W           | 60W            | 75W                              |                               |        |
| 气流量  | 300立方米/小时     | 450立方米/小时      | 600立方米/小时                        |                               |        |
| 噪音   | 50分贝          | 55分贝           |                                  | 60分贝                          |        |
| 过滤系统 | 第一层           | 第二层            | 第三层                              | 第四层                           | 第五层    |
|      | 活性氧发生器        | 前置过滤网          | HEPA过滤网                          | 纳米滤芯                          | 排气风扇   |
| 功能   | 杀菌、除异味        | 过滤尘埃和毛屑        | 吸附更小的悬浮粒子，如尘埃和毛屑，以及过敏原、花粉、病毒、细菌等 | 分解、氧化有害物质，如挥发性有机物、甲醛等，转化成新鲜空气 | 新鲜空气排出 |
| 保养   | 无需更换          | 可水洗，每1-3个月清洗一次 | 6-18个月更换一次                       | 2-4年更换一次                      | 无需更换   |
|      |               |                | 开关指示灯一直红灯闪烁并发出“哔哔”两声             | 开关指示灯一直红灯闪烁并发出“哔哔哔”三声         |        |

## 执行标准

GB 4706.1-2005 家用和类似用途电器的安全第1部分：通用要求

GB 4706.45-2008家用和类似用途电器的安全空气净化器的特殊要求

本产品按家用标准设计制造，请勿用于商用或工业用途。



## CONTENTS

|    |                          |
|----|--------------------------|
| 16 | Product Introduction     |
| 17 | Product Features         |
| 18 | Parts Construction       |
| 19 | Precautions              |
| 21 | Operation Guide          |
| 27 | Cleaning and Maintenance |
| 29 | Problem shooting         |
| 30 | Technical Specifications |
| 30 | Applicable Standards     |

## Product Introduction

Thank you for your purchase and selection and welcome to visit BORGGO enterprise, BA-1000 indoor air purifier is the professional air purification which adopts the NCCO(Nano-Confined Catalytic Oxidation) Technology, the unique global patent developed by The Hong Kong University of Science and Technology. It can quickly purify indoor air, so that you can enjoy the clean air as if in the natural oxygen bar. For best results, place the high-performance air purifiers where you stay for the longest period in your daily life, such as living room or bedroom.

Indoor pollutants mainly include: formaldehyde, benzene, ammonia, radon, volatile organic compounds and dust, which mainly comes from construction materials, interior decoration, ornaments and animals and plants. Long-term contact can lead to chronic respiratory disease, pregnancy complications, neonatal body caused by reduced chromosomal abnormalities, and even lead to nasopharyngeal carcinoma.

This indoor air purifiers adopts the NCCO (Nano-Confined Catalytic Oxidation) Technology. Combined with the 5 layer filtration, including HEPA filters, the treatment efficiency is much better than the traditional pure HEPA filter purifier. Effectively decompose formaldehyde, benzene, ammonia, radon and other pollutants, and filter dust. Its main functions are as follows:

1. Disinfection, in addition to odor removal
2. To eliminate viruses, bacteria, fungi
3. Filter the air of dust, pollen, particulates
4. Decomposition of all volatile organic compounds TVOC transfer into harmless substance

## Product Features

1. International Patent NCCO Nano-Catalytic Oxidation Technology, 5 weight extremely clean, family health care
2. filter dust, bacteria Against Drugs, odor removal, degradation of gas everything good, fast to improve indoor air quality
3. super quiet design, superior to enjoy life, like exposure to nature
4. intelligent design, low power consumption, less than a kilowatt hour would be consumed for whole day service, more environmentally friendly energy
5. 12-hour time booking functions, humernized design, convenient in use.
6. LCD dynamic display operating status, luxury demonstrated.
7. Nano filter has long life so no frequent replacement and can save costs.
8. Intelligent life reminder system, accurately give notice when HEPA filter and nano filter should be replaced.
9. Front filter can be removed for washing or cleaning which make maintenance be more convenient
10. the former Gate has a safety device, which gives note for installing, more humanized design.
11. Three gears for speed regulation, the specially designed speed gear, fully satisfy the different needs of life
12. the strong centrifugal fans, large air transport volume, quick air purification

## Component Description

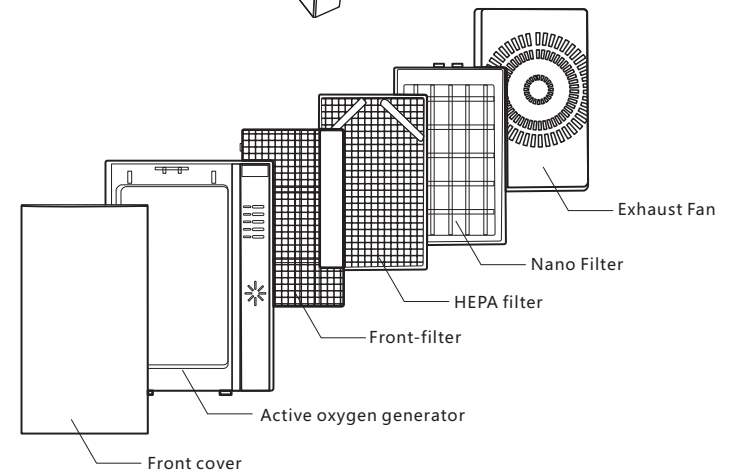
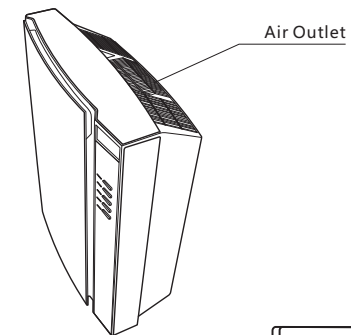
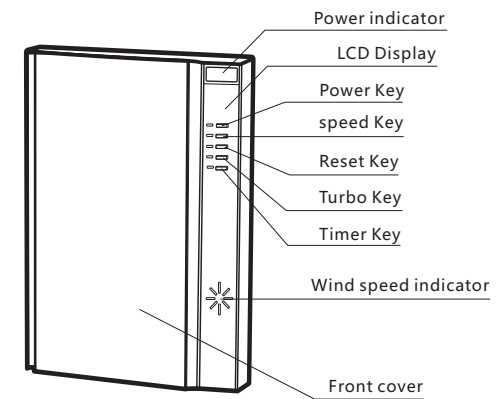

## Precautions

Read the instructions carefully and keep for future reference before using this BA-1000 indoor air purifiers

### Danger

1. Do not allow water or any other liquid or flammable detergent flow into the product, so as to avoid electric shock and (or) fire.
2. Do not use water or any other liquid or (flammable) cleaner to clean the product, so as to avoid electric shock and (or) fire.

### Warning

1. First make sure the voltage indicated on the bottom of product is compatible with the local voltage before plugging in, or it may damage the product.
2. Please keep the power cord intact. Power cord should not be cut, damaged, excessively bent, pulled, twisted, knotted, or close to heating area, and it should not be pressured or compressed or self-assembled, Otherwise, the damaged power cord will cause short circuit or fire.
3. When power cord, plug or socket get loose, do not use. Otherwise, it will cause electric shock, short circuit and fire.
4. Do not let people with physical disabilities, or with sensory & mental disorders or lack of related experience & knowledge (including children) private access to or use of this product. Or there will be risk of electric shock.
5. Do not use wet hand to unplug. Otherwise, there will be an electric shock, which results in injury.
6. Do not block air inlet or outlet, which would significantly reduce the product purification efficiency, even lead to product damage.

### Attention

1. This product is specifically designed for home and office, do not use it in those environments with much dust or fumes, so as not to damage and shorten filter life.

2. Please place & use this product on dry, solid, smooth level surface, so to avoid accidents.
3. At least 20 cm of spaces should be left for back and two sides of product, 30 cm should be left for the above of the product.
4. Do not place anything on top of the product, and do not sit on the product to avoid product damage.
5. Do not place the product directly below the air-conditioner to prevent condensation droplets into the product so to avoid product damage.
6. This product is equipped with safety devices, if the filtering system is not installed correctly, the product will not start work.
7. Only the original filter specifically designed by Borgoo can be used for the product, do not use any other filter. Otherwise the product does not work, or even results in product damage.
9. Do not knock the product with a hard object in order to avoid product damage.
10. Please always use the handle on the back to pull or remove the product, so as not to cause product damage.
11. Do not insert fingers or foreign objects into the air inlet and outlet. Doing so may lead to product damage, and even risk of electric shock.
12. Do not sit on the machine or rely in the machine, in order to avoid bodily injury or damage to the machine.
13. When you use insect repellent spray indoors or in a place filled with flammable gas, do not use this product. Or otherwise it may cause a fire hazard.
14. Do not use this product near to gas appliances, heating devices or stove, or otherwise it may lead to product damage, even fire.
15. Please keep this product away from the electric wave equipment for at least 2 meters, so as to avoid wave interference.
16. In the use of heating, please keep good ventilation to avoid carbon monoxide production.
17. Be sure to unplug the appliance before cleaning or after use.
18. Do not attempt to disassemble or repair products. If the product needs repair, to avoid injury, please contact Borgoo customer service center, for repair by manufacturer or designated service center.

# Operation Guide

## First use

1. Make an inventory for random accessories and documents, read the instruction manual and save for future reference.
2. Remove all packaging, use a soft dry cloth to clean all the removable parts, the product cavity, and then re-assemble parts. (Please refer to cleaning, installation and removal guide).
3. Put the product on a dry, solid, smooth and level surface on the rear and sides to ensure products are left with a reasonable space of at least 20 cm, 30 cm above the product.
4. Check power, sockets, etc., to confirm it complies with product "manual" requirement, and then plug into the wall socket. Product will start normally.

## Parts Disassembly Method

Install parts in the opposite order to the disassembly procedure.

1. Make sure the product off and unplugged.
2. Hold the top of the front cover, pull out cover locker from the front cover, and then remove the front cover upward.

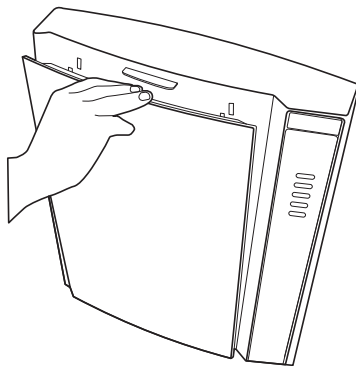

3. Pinch filtration system under the pressure to prominent positions, remove the entire filter system.

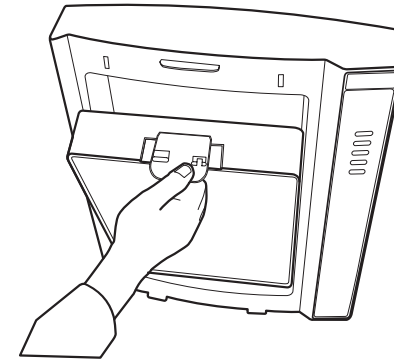

4. Pinch front filter prominent position, remove the front filter gently.

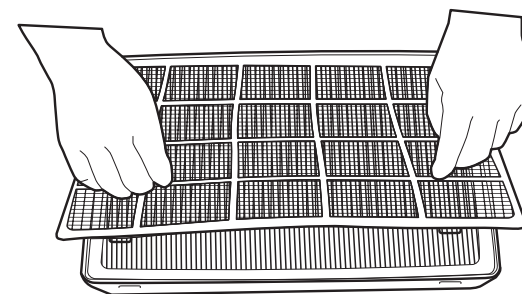

5. Pull the belts on both sides lightly, and HEPA filters can be taken out easily.

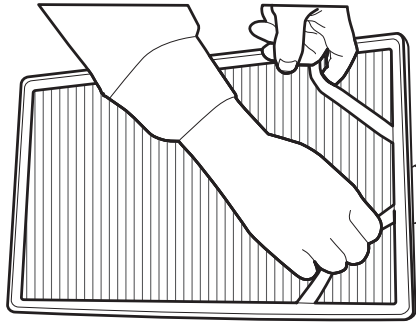

2. Hold the front edge of the filter, insert the protruding parts of the filter into the slot on filtration system side, and then bend the other side, the pre-filter to be fully loaded.

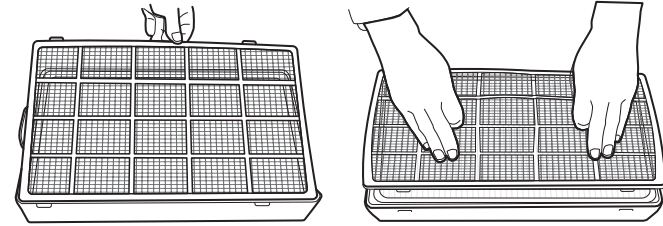

### Component assembly method

1. Seize the belt on both sides of HEPA filters, install filter into the groove of subassembly.

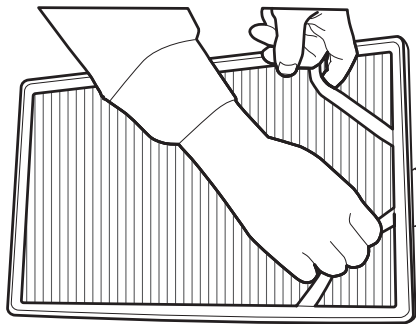

3. Filtration system will be assembled into the fuselage.

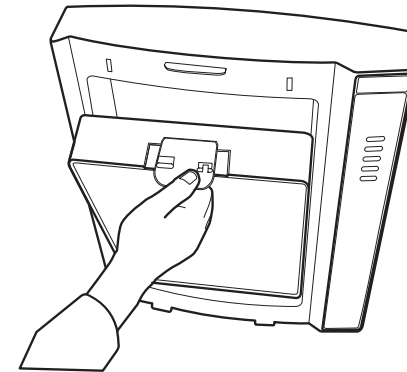

4. Install the bottom clip of front cover to the clip base of fuselage, then push upper end gently to fix the cover.

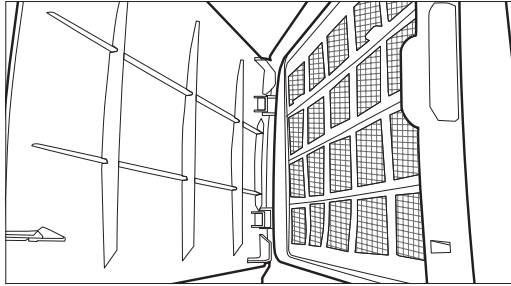

## Usage

### Standby mode:

1. All the lights of product are on when connected to the power. It is standby mode. Without pressing any key in 30 seconds, all lights will turn off automatically.
2. For further operation, press the top "POWER" button, indicator light and the product operate.

### How to switch machines:

1. To start the air purifier, press the "POWER" button after connect the power.
2. The red indicator at the top right corner illuminates up, indicating the product is in operation. 5 minutes later the light turns green, indicating product is operating normally.
3. Motor speed is default at the mid-range when turning on, liquid crystal display shows "L2".
4. If the filter system is installed incorrect, when pressing the "POWER" button, the LCD display will show "Er", indicating installation error. It needs re-install.
5. Press the "POWER" button to turn off, the product stops working.

### How to set up wind speed:

1. Boot mode, press the "SPEED" button to adjust the motor speed, set up the wind speed.
2. LCD display shows "L1": motor speed is low
3. LCD display shows "L2": the motor speed switches to mid-range
4. LCD display shows the "L3": motor speed is high

### Reset Function:

1. Boot mode, press the "RESET" button, cancel the indication function of HEPA filters and Nano filter, at the same time clear the wind speed, speed cleaning, time settings. Product switches back to the default settings: LCD display shows "L2", the motor speed to mid-range.

### Set of reactive oxygen species:

1. Boot Mode, press the "TURBO" button, active oxygen generators in operation, the LCD screen will display "AU".
2. After the active oxygen generator operates for 60 seconds, it will revert to the default settings automatically: LCD display shows "L2", the motor speed to mid-range.
3. If need active oxygen generator to continue to operate, press the "TURBO" button again.
4. When you want to achieve the rapid purification in a short time, you can do likewise.

### Time settings:

1. Boot mode, press the "TIMER" button, choose from 1 to 12 hours of operating time, and start the countdown. When it countdowns to zero, the product will shut down automatically.

### Intelligence functions:

1. When the HEPA filter absorb too much dust, the top switch indicator light will keep flashing in red and sound "beep" twice, to remind you to replace the HEPA filter. Under normal circumstances the service life of HEPA filter lasts for 18 months.
2. When the nano-filter needs to be replaced, the top switch indicator light will keep flashing in red and sound "beep" three times. As the nano-filter updates itself, the life can extend to 4 years.

## Cleaning and Maintenance

### Note:

Do not immerse this product in water or any other liquid.

Do not use any corrosive or flammable cleaning agents (such as bleach or alcohol) to clean any part of this product.

### Body clean:

1. Clean air purifier, make sure to unplug the machine, cut off the power supply.
2. Use a soft dry cloth to wipe the dust off the machine.
3. Use a soft dry cloth to clean the air inlet or outlet.

### Filtration system cleaning:

1. Filtration system consists of pre-filter, HEPA filter, nano filter component. Filter life depends on the air pollution degree of the use circumstances.
2. Pre-filter can be washed with water, the proposed cleaning frequency is once every 1-3 months.
3. HEPA filters can not be washed with water, on general condition the service life of HEPA filters can lasts for 18 months.
4. Nano filter can not be washed with water. Due to the function of updating itself, the life can extend to 4 years.

### How to clean pre-filter:

1. Make sure the power supply cut off before cleaning.
2. Take off pre-filter according to Parts Disassembly Procedure 1,2,3.
3. Please use water to clean or vacuum cleaner, and then dry the pre-filter.
4. Install product with Parts Disassembly Procedure 2,3,4.
5. Turn on with normal method. The product will operate as usual.

### How to replace the HEPA filter:

When you heard "beep " twice and the top switch indicator light keeps flashing in red, please replace the HEPA filter.

1. Make sure the power supply cut off before replacing.
2. Take off the old HEPA filter according to Parts Disassembly Procedure 1,2,3.
3. Remove the outer packing of the new HEPA filter.
4. Install product with Parts Disassembly Procedure 2,3,4.
5. Turn on and press the "RESET" button for 2 seconds to reset the reminding function. Product can operate as usual.

### How to replace the nano-filter:

When you heard three "beep" three times, and the top switch indicator light keeps flashing in red, please replace with the new nano-filter, and replace the HEPA filter at the same time will be better.

1. Make sure the power supply cut off before replacing.
2. Take off the old nano filter according to Parts Disassembly Procedure 1,2,3,4.
3. Remove the outer packing of the new nano filter.
4. Install product with Parts Disassembly Procedure 1,2,3,4.
5. Turn on and press the "RESET" button for 2 seconds to reset the reminding function. Product can operate as usual.

## Problem Shooting

Before entrust for repair, please read this instruction carefully and check below issues.

|   |  |  |
|---|--|--|
| Product does not work after pressing the switch button.                                   | Please check if the power supply is connected                | Connect the power supply correctly.  |
|   | Please check if the filtration system is installed correctly | Install the filtration system correctly.   |
|   | Please check if the power cord is damaged                    | Contact Borgoo customer service center for repair by the manufacturer or appointed service center.   |
| Can not filter dust   | Please check if the filtration system is installed correctly | Install the filtration system correctly.   |
|   | Please check if the pre-filter absorb too much dust or hair  | Please clean pre-filter in time.   |
|   | Check if the HEPA filter absorb too much dust                | Check the HEPA filter and replace in time. Its life lasts for 18 months generally.   |
| Switch indicator light flashes in red and sounds "beep" twice                             | Please replace with the new HEPA filter                      | Check the HEPA filter and replace in time. Its life lasts for 18 months generally.   |
| Switch indicator light flashes in red and sounds "beep" three times                       | Please replace with the new Nano filter                      | Check the Nano-filter and replace in time. Its life lasts for 4 years generally, and it's better to replace with the new HEPA filter at the same time. |
| Switch indicator light is still flashing after replacing the HEPA filters and Nano-filter | The reminding function was not reset after replacing         | Press the "RESET" button for 2 seconds   |
| LCD display shows "Er" and no response pressing any key.                                  | Filter installed incorrectly                                 | Please re-install the filter, and make sure it is in the clip base of filtering system properly.   |

## Technical Specification

|                   |   |  |  |  |                     |
|-------------------|---|--|--|--|---------------------|
| Product           | Indoor Air Purifier                       |  |  |  |                     |
| Model             | BA-1000                                   |  |  |  |                     |
| Rated voltage     | 220V~                                     |  |  |  |                     |
| Rated frequency   | 50Hz                                      |  |  |  |                     |
| Use area          | 46Square meters                           |  |  |  |                     |
| Dimension         | 419*210*574mm                             |  |  |  |                     |
| Net Weight        | 9.5KG                                     |  |  |  |                     |
| Rated power       | 55W                                       | 60W  | 75W  |  |                     |
| Gas flow          | 300 cubic meters / hour                   | 450 cubic meters / hour                                  | 600 cubic meters / hour  |  |                     |
| Noise             | 50 dB                                     | 55dB   | 60dB   |  |                     |
| Filtration system | First layer                               | Second layer   | Third layer  | Fourth layer   | Fifth layer         |
|                   | Active oxygen generator                   | Pre-filter   | HEPA filter  | Nano Filter  | Exhaust Fan         |
| Function          | Sterilization, cleaning up peculiar smell | Filter dust and hair                                     | Adsorption of smaller particulates such as dust and dander, allergens, pollen, viruses, bacteria, etc. | Decompose and oxidate harmful substances such as volatile organic compounds, formaldehyde, etc., change to fresh air | Fresh air discharge |
| Maintenance       | No replacement                            | Can be washed with water, cleaning once every 1-3 months | 6-18 months to replace<br>Switch indicator light flashes in red and sounds "beep" twice                | 2-4 years to replace<br>Switch indicator light flashes in red and sounds "beep" three times                          | No replacement      |

## Applicable Standard

GB 4706.1-2005 household and similar electrical appliances Part 1: General requirements

GB 4706.45-2008 household and similar electrical appliances

Particular requirements for air purifier

This product is designed and manufactured for household, not for commercial or industrial use.



文件尺寸：286\*216(含出血3mm)

成品展开尺寸：280\*210

成品折叠后尺寸：140\*210

颜色：PANTONE 8423C