

# mitsubishi

## Refrigerator-Freezer

### 冷藏冷凍雪櫃

# Easy Refrigerator Use

## 簡易使用說明



**MR-BF43B**  
**MR-BF36B**  
**MR-BF32B**

OPERATING  
INSTRUCTIONS  
使用須知



## Contents 目錄

### Before using your refrigerator

使用前準備

For your safety, please be sure to follow these instructions. 2  
為了安全請務必遵守

From installing to running your refrigerator. 4  
從安放冰箱到開始運轉

### Smart tips for using your refrigerator

雪櫃使用貼士

How to adjust the temperature. 5  
溫度的調節方法

### Using each compartment

各間格的使用

Refrigerator Compartment. 6  
冷藏室

Vegetable case and Freezer Compartment. 7  
蔬果盒・冷凍室

### Maintenance and troubleshooting

保養及故障處理

How to remove and clean accessories. 8  
附屬品的拆下方法與清潔

If you think “is this a problem?” 10  
認為可能發生故障時

### Accessories

配件

11

### MEMO

備忘

- Please read this manual carefully and follow the information contained within. In particular, be sure to read the safety precautions before using this refrigerator.
- Be sure to receive your copy of the warranty from the retailer and confirm that the purchase date and retailer name are written on the warranty.
- Store this operating instructions manual and the warranty in a safe place.
- This refrigerator was manufactured for refrigerating and freezing of foods in general households. For commercial use, please use a commercial refrigerator-freezer.
- The photographs and illustrations contained in this manual are for the MR-BF36B. While the capacity and dimensions of the MR-BF36B are different from the MR-BF32B, MR-BF43B the operation is the same.
- The principal plastic components indicate the material name to facilitate recycling.
- 請細閱此說明書，並依照書中指引使用雪櫃。使用雪櫃前，請務必細閱有關安全措施。
- 請確定已從經銷商處取得保養書。保養書上應列明購買日期及經銷商號。
- 請將此使用說明及保養書妥為保存。
- 此冷藏冷凍雪櫃只宜作為一般家居冷藏及冷凍食物用。如要作商業用途，請另購商用冷藏冷凍雪櫃。
- 此說明書內所載為 MR-BF36B 型號的相片及插圖。MR-BF36B 型號的容量及尺寸與 MR-BF32B, MR-BF43B 不同，但操作方式一樣。
- 主要塑料組成部份顯示有物料的名稱，以方便循環再用。

# For your safety, please be sure to follow these instructions.

■ The types of danger that can result from improper handling are explained in the sections below.

## Warning

Mishandling can lead to serious injury or death.

## Caution

Mishandling can lead to bodily injury or loss of home and household contents.

■ The symbols illustrated below have the following meanings.

	Do not do
	Do not touch
	Do not take apart, repair or convert
	Do not get wet
	Do not touch with wet hands
	Always follow instructions
	Always connect an earth wire
	Always unplug electrical plug from socket

■ When something abnormal or unusual occurs, turn off immediately and consult with “the store where you purchased the unit” or with a “Mitsubishi Electric repair counter.”

## Warning

### When installing your unit

#### Allow some space around the refrigerator.

If the refrigerant (gas) leaks, it can remain in the area and there's a risk that it may cause a fire or explosion.

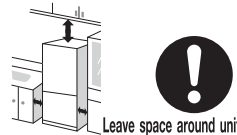

#### To be prepared for an earthquake, affix to a strong wall or column.

Not doing so may cause injuries from the refrigerator toppling over.



#### Do not install in an outdoor area where water can get on it or where there is a lot of moisture.

Due to insulation failure, it may cause an electric shock or fire.

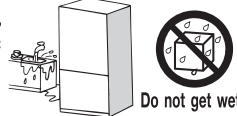

#### Use a dedicated outlet for the power supply that meets the rating specified on the rating label. (The rating label is located on the door-liner of the refrigerator compartment.)

Using an extension cord or plugging in too many power cords into the outlet can cause heat buildup or a fire.



#### If the power cord is damaged.

If the power cord is damaged call Mitsubishi Electric Service Centre for a technician to replace power cord. The power cord should be designed for this model.



Service Call

#### Keep the electrical plug cord facing downwards and insert the plug in fully.

If it is plugged with the cord facing upward, extra pressure gets exerted on it which can cause it to heat up or ignite.



### About the electrical outlet and electrical plug

#### When replacing the interior refrigerator light or when taking care of the unit, pull out the electrical plug.

Not doing so can result in an electric shock or injury.



#### Do not push the electrical plug with the back of the refrigerator. Do not damage the electrical cord.

If the plug is pressed by the refrigerator, or if the cord is bent, bundled, or a heavy object is placed on it, it can cause an electric shock or a fire.



#### Do not use damaged cords or plugs or loose outlets.

Using them can result in an electric shock or injury.



#### Do not remove the electrical plug by pulling the cord.

The cord can become damaged and can cause an electric shock or a fire.



#### Remove dust from the electrical plug.

Not doing so can cause a fire from insulation failure.



#### Do not plug or unplug the electrical plug with wet hands.

It can cause an electric shock.



## Caution

### Installing and Transporting

#### Install on a strong level floor and adjust the adjustable legs to fix firmly.

The refrigerator may move and cause injury.

Page 4

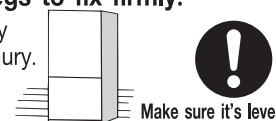

#### When carrying, use the handles made for carrying.

If other parts are held while carrying, it can cause injury.

Page 9



### About Using

#### Do not force food items into the refrigerator. Do not use force to pull out shelves.

Food items may fall out, causing injury.















#### Do not touch foods or containers in the freezer compartment with wet hands.

Doing so can cause freezer burn.









# Warning

## About using your refrigerator

<p><b>Do not put any vessels, jars, etc. that contain water on top of the refrigerator.</b></p> <p>If water gets onto electrical parts, it will cause an electric shock or a fire.</p>  <p>Do not get wet</p>	<p><b>Do not use electrical products inside the refrigerator unit.</b></p> <p>If the refrigerant (gas) is leaking inside the unit, there is a risk that a spark from the electrical product's contact can be a source for ignition or explosion.</p>  <p>Do not do</p>	<p><b>Do not store volatile products that can easily ignite.</b></p> <p>Benzene, cosmetics and hair styling products can be the cause for igniting fires and explosion.</p>  <p>Do not store</p>
<p><b>Do not place items on top of the refrigerator.</b></p> <p>Items may drop from opening and closing the door and can cause injury.</p>  <p>Do not do</p>	<p><b>Do not store pharmaceuticals or scientific test material.</b></p> <p>Anything that needs strict supervision must not be stored in a home-use refrigerator.</p>  <p>Do not store</p>	<p><b>Use the specified rated refrigerator light bulb.</b></p> <p>If you use one that is not specified, it may cause a fire.</p>  <p>Use specified products</p> <p>Page 9</p>
<p><b>Do not hang on the door or door handle, and do not get on compartment drawer-type doors.</b></p> <p>The refrigerator can topple over causing injury.</p>  <p>Do not do</p>	<p><b>Do not damage the refrigerant circuit (piping) of the refrigerator; do not drive in screws.</b></p> <p>Because a flammable refrigerant (gas) is used, there is the danger of igniting or explosion.</p>  <p>Do not do</p>	<p><b>If you sense a gas leakage, do not touch the refrigerator. Open the window and ventilate the room.</b></p> <p>A spark from the electrical contact can cause an explosion or a fire.</p>  <p>Ventilate the room</p>
<p><b>Do not wash with water or spill liquid food items on the unit.</b></p> <p>If water and food liquids get on the unit, it can cause an electric shock or a fire. If that happens, dry off immediately.</p>  <p>Do not get wet</p>	<p><b>Do not use flammable sprays nearby.</b></p> <p>A spark from the electrical contact can ignite and cause a fire.</p>  <p>Do not use</p>	<p><b>Do not use in a shed or a garage.</b></p> <p>If small animals damage the wiring, it can cause an electric shock or a fire.</p>  <p>Do not use</p>



## About Malfunctions / Long Term Care

<p><b>If the refrigerant circuit (piping) is damaged, do not touch the refrigerator, avoid using any heating flame, open the window and ventilate the room.</b></p> <p>When the refrigerant circuit is damaged, please consult the store in which the unit was purchased.</p>  <p>Ventilate the room</p>	<p><b>If something abnormal occurs (such as a burning smell), pull out the electrical plug and stop the refrigerator from running.</b></p> <p>If it continues to run in an abnormal state, it can cause an electrical shock or a fire.</p>  <p>Pull out the plug</p>	<p><b>Do not take apart, repair or convert. Do not continue to use with damaged parts.</b></p> <p>This can cause injury, an electric shock or a fire.</p>  <p>Do not take apart</p>
<p><b>If there is a possible danger of a child getting trapped inside while the refrigerator is not in use, please pull off the door seal.</b></p> <p>It is dangerous if the child gets shut inside.</p>  <p>Remove the door seal</p>	<p><b>If you will not be using the refrigerator for a long period of time, after pulling out the electrical plug, open the door and let the interior dry out.</b></p> <p>If it is not dried adequately, the cooling unit may corrode causing the refrigerant (gas) to leak which can then cause the danger of ignition or explosion.</p>  <p>Dry properly</p>	<p><b>When disposing of the unit, transfer it to the store that you purchased it or to the municipality.</b></p> <p>If it is neglected and refrigerant (gas) leaks, ignition or an explosion may be caused due to heat from a fire.</p>  <p>Transfer it over</p>

- This appliance is not intended for use by young children or infirm persons unless they have been adequately supervised by a responsible person to ensure that they can use the appliance safely.
- Young children should be supervised to ensure that they do not play with the appliance.
- This appliance is not intended for use by persons (including children) with reduced physical, sensory or mental capabilities, or lack of experience and knowledge, unless they have been given supervision or instruction concerning use of the appliance by a person responsible for their safety. Children should be supervised to ensure that they do not play with the appliance.

# Caution

## About Using Your Unit

<p><b>Do not store bottles in the freezer compartment.</b></p> <p>If the center freezes and bottles crack, it will cause injury.</p>  <p>Do not store</p>	<p><b>Do not eat foods that have a bad smell or are discolored.</b></p> <p>Doing so may cause food poisoning or other illnesses.</p>  <p>Do not do</p>	<p><b>When opening and closing the door.</b></p> <ul style="list-style-type: none"> <li>• Do not open or close the door while someone else is in the way.</li> <li>• Do not place your fingers at the top of drawer-type doors when closing the door.</li> <li>• Do not close the lower drawers with your foot (as it may get caught).</li> <li>• Do not open or close the door forcefully (food items may fall and cause injuries)</li> </ul>  <p>Do not do</p>
<p><b>Do not place your hands or feet under the refrigerator.</b></p> <p>You can get injured from something such as the steel plate.</p>  <p>Do not touch</p>	<p><b>Close the door by holding the handle.</b></p> <p>Hold it in a way so that you don't get your fingers caught in the door. Not doing this may cause injury.</p>  <p>Hold the handle</p>	

For your safety, please be sure to follow these instructions.

# From installing to running your refrigerator.

From installing to running your refrigerator.

## 1 Installation

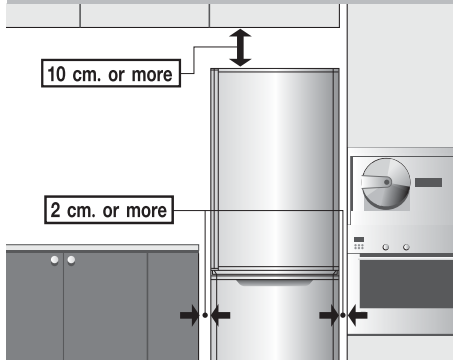

### Where to install your fridge

**Install in a place where there is no direct sunlight or heat, and with good ventilation.**

This protects against a decrease in cooling power and saves on electricity bills.

**Install in a place with low humidity.**

This prevents rust, electric shock or fires from occurring.

**Install on a solid and level floor.**

This prevents vibrations, noise, and partially open doors or doors left ajar.

● If the refrigerator adjustment feet sink easily into the flooring material, please lay a strong board on top of the flooring. (Prevent changes or discoloring by its mass or heat.)

**Install away from other appliances.**

This prevents noise or image disturbances to the television, etc.

### Leave a space around the unit for heat to escape

**Leave a space of more than 2 cm to the left and right, and more than 10 cm from the ceiling, and more than 5 cm from the back.**

This is to allow heat to escape from the top, the back and sides.

**The outside of the unit will get hot.**

When you first start running the unit, or in the summer, there may be times when the temperature can go over 50 – 60 °C.

### Warning

Do not block the refrigerator's ventilation opening or the spaces around the refrigerator.

If the refrigerator (gas) leaks, it may remain in the area creating the risk of ignition or an explosion.

## 2 Turning on the power / installing an earth wire

To get the refrigerator cooled down faster, plug it in right after installing.

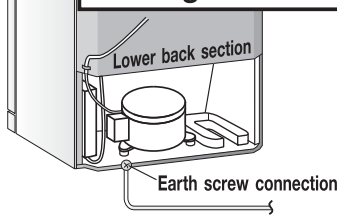

**Use a dedicated outlet for the power supply that meets the rating specified on the rating label.**

**(The rating label is located on the door-liner of the refrigerator compartment.)**

**To prevent electric shock, installing an earth wire is recommended.**

Install an earth wire or an earth leakage circuit breaker, especially when installing takes place where there is a lot of dampness (wooden floor, washing room, basement, etc.).

**If there is an earth terminal.**

Connect the earth wire to the earth connection screw (⊕), and attach the earth terminal. Also, for the earth wire (copper wire, diameter 1.6mm), please purchase at the store where you purchased your refrigerator.

**If you do not have an earth terminal.**

Request one at the store where you purchased your refrigerator and have the earthing done. (D-class earthing/grounding – to be paid for by customer.)

**If you are installing in an especially damp area.**

Besides the earthing, it is required that you have an earth leakage circuit breaker installed. Please consult with the store where you purchased your unit.

**Where connections are forbidden.**

- Water pipes, gas pipes (due to risk of electric shock, explosion.)
- Telephone lines or a lightning rod earth (dangerous if lightning strikes.)

## 3 Making adjustments and Affixing

Turn in the direction of the arrows and lower the adjustable legs to place on the floor.

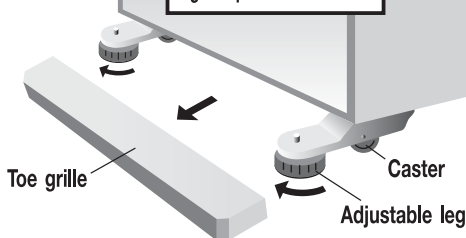

※ The adjustable legs covers are packed in together with the refrigerator for shipping.

**Turn the adjustable legs to get them to touch the floor and let the front casters up, then affix.**

Prevents vibration, noise, movement and the partial opening of doors.

### Caution

If it is not done properly, the refrigerator may move and cause injury.

- Make sure the left and right sides are level, and keep the front at a slightly higher angle. This makes closing the door easier and prevents the door from partially opening.

**When the tilt cannot be corrected with the adjustable legs.**

If installed in a corner of a room, there are times when one side of the back legs sinks into the floor. When that happens, please make adjustments in the back with casters (to be purchased) or lay a strong board underneath. (Normally, the thickness of the board should be 2 - 3 mm.) For casters, please inquire at the store where you purchased your unit. Model No.: MRPR-03CS

**About the direction of the door.**

If the installation space is not level, or if after a few days, the weight of the food causes the leg to sink, the door will look like it is sagging. (There are times that the weight of food stored in the refrigerator exceeds 100 kilograms.) Please adjust the adjustable legs by turning them in the direction indicated in the diagram.

If the left side of the door is sagging

If the right side of the door is sagging

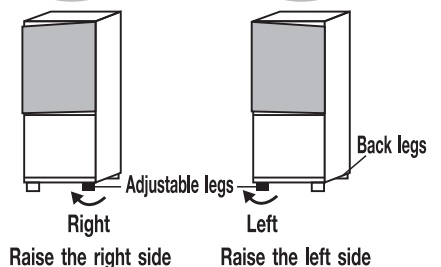

## 4 For Earthquake Preparation

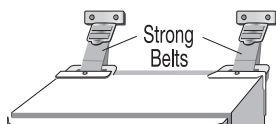

**Attach the strong belts in the upper back area (2 belts) and affix them to a sturdy place such as a wall or column.**

### Warning

The refrigerator can topple over and cause injuries.

For Tackle Prevention Belts (to be purchased) for your refrigerator, please inquire at the store in which you purchased your unit. Model No. MRPR-02BL

# How to adjust the temperature.

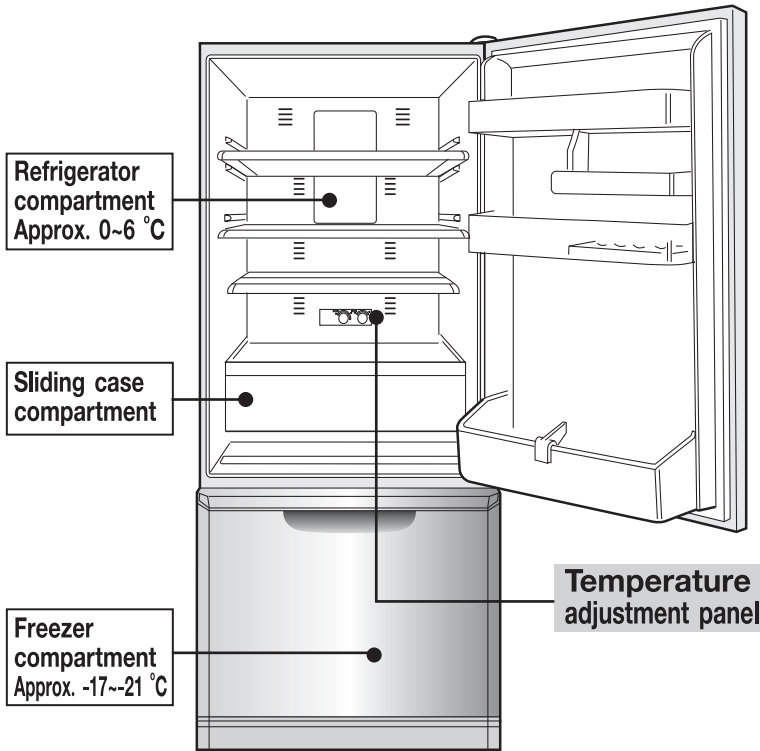

※ Illustration of the MR-BF36B

※ For the temperatures indicated, the freezer and refrigerator compartments were adjusted at the "Normal" position, with an ambient temperature of 30 °C, with refrigerator doors closed and containing no food; after the temperature stabilized, the temperature criteria was measured toward the lower-mid interior of the refrigerator.

Please follow these tips

## To cool the unit quickly

Since it takes time to cool down, please insert the electrical plug as soon as possible. It normally takes about 4 - 5 hours to cool down. If you insert the electrical plug immediately after installation, it will not cause damage to your unit.

- When inserting food, make sure to allow some space between items.
- Put in warm food items or ice cream after the refrigerator has been adequately cooled down.
- Keep opening and closing of the door to a minimum, and keep it open for only a short time.

In the summer time when it's hot, it will take approx. 24 hours to make the first batch of ice.

## About Non-Freon Refrigerators

Do not damage the refrigerant circuit (piping) and do not drive in screws.

Non-freon refrigerant (gas) has the possibility of igniting, but since the refrigerant circuit is tightly sealed, normally, it will not leak out.

⚠ Warning

If there is damage to the refrigerant circuit:

1. Avoid the use of any flame or electrical appliances.
2. Open the window and ventilate the room well.

After that, please contact the store where you purchased the refrigerator.

## About the Door Alarm

The number of times that the door alarm (beeping sound) sounds indicates the following situation.

Sounds off 4 times ※ Indicates that either the refrigerator or freezer door is open. Please close the door.

- ※ Each time the door is open for over 1 minute, the alarm will sound 4 times. If open for over 5 minutes, it will sound continually. Make sure that there is no food caught on the door (on the seal strip/behind the case).
- Please check for this once a month.
  - Please consult the store where you purchased your unit if the alarm sounds on even after the door is closed.

Usually set at "MID" setting

If it's too cold  
Gets 2~3 °C higher than "MID"

If you want it colder  
Gets 2~3 °C lower than "MID"

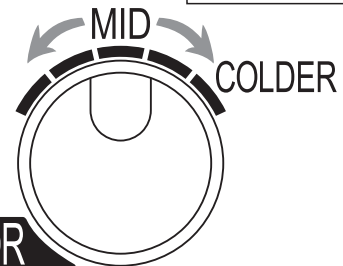

## REFRIGERATOR

- Slide compartment and vegetable compartment temperatures will change with temperature adjustments made to the refrigerator compartment.

Usually set at "MID" setting

If it's too cold  
Gets 2~3 °C higher than "MID"

If you want it colder  
Gets 2~3 °C lower than "MID"

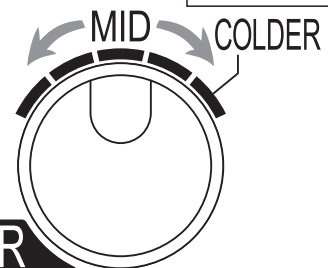

## FREEZER

## Hints on how to save on electricity.

### Electricity-saving tips

- Allow some space between food items.
- Cool down hot foods before placing them in the fridge.
- Keep door openings/closings to a minimum. And, keep the times short.
- When closing the door, do not let food, plastic bags, the electrical cord, etc. get caught in the doorway.

Even if the door is slightly ajar, frost or condensation may form and it will not cool properly. Or, water droplets may form.

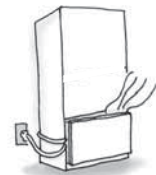

### Tips on Storing



Wipe



Wrap

This prevents drying or absorbing of odors.

# Refrigerator Compartment.

Refrigerator

Air blowing outlet

Adjustable shelf

Two-way flexishelf

LED light vitamin C increasing.

Sliding case

Free pocket

Small-Items pocket

※ Only with MR-BF36B,  
MR-BF43B

Free egg tray

Bottle stopper

Bottle pocket

※ Illustration of MR-BF36B

## Adjustable shelving

The position of the shelves can be adjusted to boost your storage space!

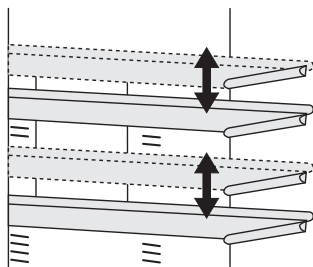

Pull out the shelves and place them in the position that suits your needs.

## Two-way flexishelf

1. Make it wider

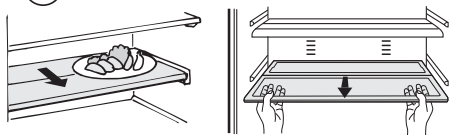

2. Push it inwards

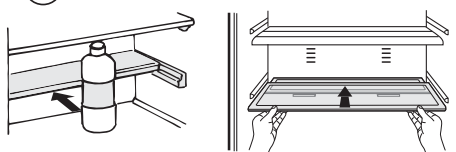

## Free egg tray

It's an egg case and a small items tray. By turning the egg case upside-down, it converts into a small items tray.

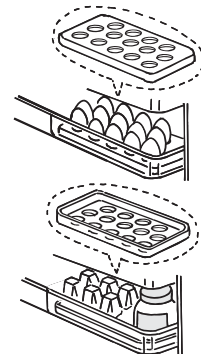

## Please follow these tips

Do not let food items protrude beyond the tray  
Do not place bottles in the front row of the bottle pocket that are too high for the pocket.

- It can cause the door to be partially open, or it can cause bottles to break.

Do not close the door if food is in front of the sliding case.

Make sure the sliding case is stored away properly.



Do not attach other types of cases sold in stores onto the outer side of the pocket.

- Cooling can get hampered due to a partially open door, food items can fall out causing injuries, or the case can get damaged.
- Do not block the air outlet with other store-bought cases.

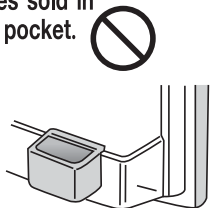

## Notice

In case your food items get frozen.

- When the ambient temperature is under 5 °C...Adjust the temperature in the refrigerator compartment to "less cold" and this will make the food less likely to freeze.
- For drinks or food items with a lot of moisture....Keep away from sections near the air blowing outlet and place in the front part of the shelf.

# Vegetable case and Freezer Compartment.

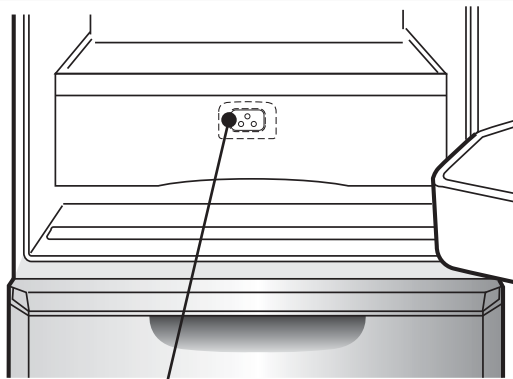

LED light vitamin C increasing.

### Please take heed

#### Do not put tall items in the sliding case.

- It can damage food items or damage the sliding case.
- If the sliding case is taken out and used separately, the Vegetable Compartment will become dry.

### Notice

- If you wrap fruit and vegetables, they will stay fresh longer. **Be avoid to disassemble, repair or alter or adjusts on LED light.**
- It might be cause damage on LED light operate.
- In case LED light damage or not operate, pls don't adjust or fix by yourself, pls contact service center.

### User tip

- Wrap fruit and vegetable with foil or plastic transparences will keep freshness, before storage them in refrigerator.
- Keep vegetable in transparence container or wrap with foil or plastic transparence; keep them touch direct to orange ray from LED light.
- The photosynthesis will proceeded and increases Vitamin C as long as the vegetable is green (Chlorophyll) such as Cabbage. The affection and difference will depends on freshness and types of the Vegetable.

### LED light vitamin C increasing.

The LED light will be installed inside of vegetable compartment, which visual light from LED, those green vegetable will increase Vitamin C and keep freshness live longer, by photosynthesis process.

The orange light from LED is visual light can see by eye, the light can pass through the transparence box or plastic bag . LED light will operate all time, even door shut or open.

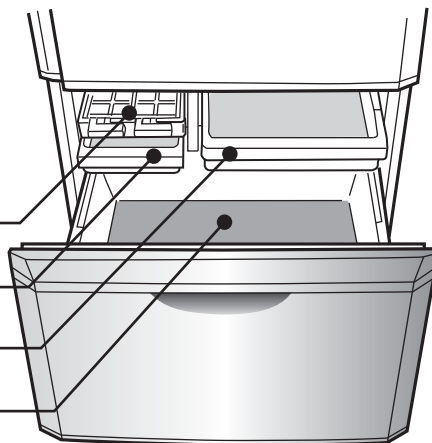
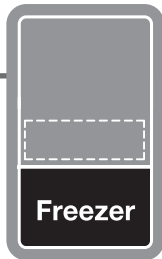

Ice tray

Ice cube box

Freezing Case (upper)

Freezing Case (lower)

### Notice

#### Put foods in the Freezing Case to below the red line seen at the front.

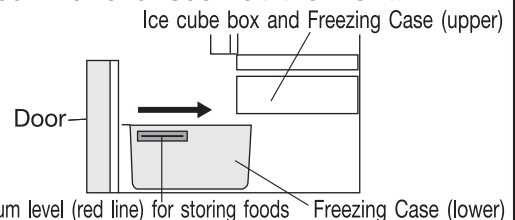

Maximum level (red line) for storing foods

- When closing the door, food can get in the way causing the door not to close properly. This can cause frost to form in the inside, or improper freezing, and will cause a malfunction.
- This may damage food and the Freezing Case, as well as the ice cube box.

## Ice making

1. Pour water into each of the sections of the ice tray up to the water line. Insert the tray completely into the ice tray holder. The ice cubes will not separate easily from the ice tray if you add too much water.
2. Once the ice cubes are made, turn the lever until the ice cubes fall into the ice cube storage box.

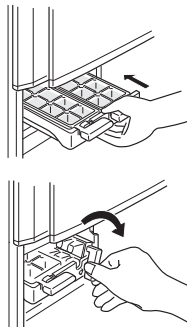

### Notice

- The ice cube storage box will break if you attempt to make ice directly in the ice cube storage box.

### User tip

- Ice made with water containing a lot of mineral substances such as mineral water, can cause to ice to form with a white sediment (white crystals). These are only mineral substances that have become crystallized. It is harmless.
- If ice is stored for a long period of time, the ice cubes may cling together or become smaller. (This is known as the phenomenon of sublimation.)
- If you're going to break clinging ice cubes apart, be careful that you do not injure your hands.

# How to remove and clean accessories.

## Before you begin cleaning

### Unplug the electrical plug.

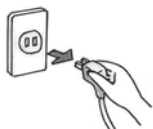

#### Warning

If it is not unplugged, it will cause an electric shock.

Wait 10 minutes or more before you replug the electrical plug into the outlet. If you plug it in immediately after unplugging it, the refrigerator will not run.

## How to clean your accessories

- Wipe with a soft cloth using warm water, or remove part and wash with water.
- For hard-to-remove dirt, first clean using a diluted kitchen detergent (neutral type). Then, finish off with a soft cloth and water. If oily substances remain for some time, the plastic may crack.
- Make sure detergents are wiped off thoroughly.
- If you use a chemical cloth, please be sure to follow the attached instructions.



### Please observe the following:

- Do not use alkaline/mild alkaline kitchen detergents, polishing powders, powder detergents, alcohol, benzene, thinner, kerosene, acid, scrub brushes, boiling water, etc. Plastic parts (door handles, caps, cases, etc.) can crack, and it will damage doors and surface paint.

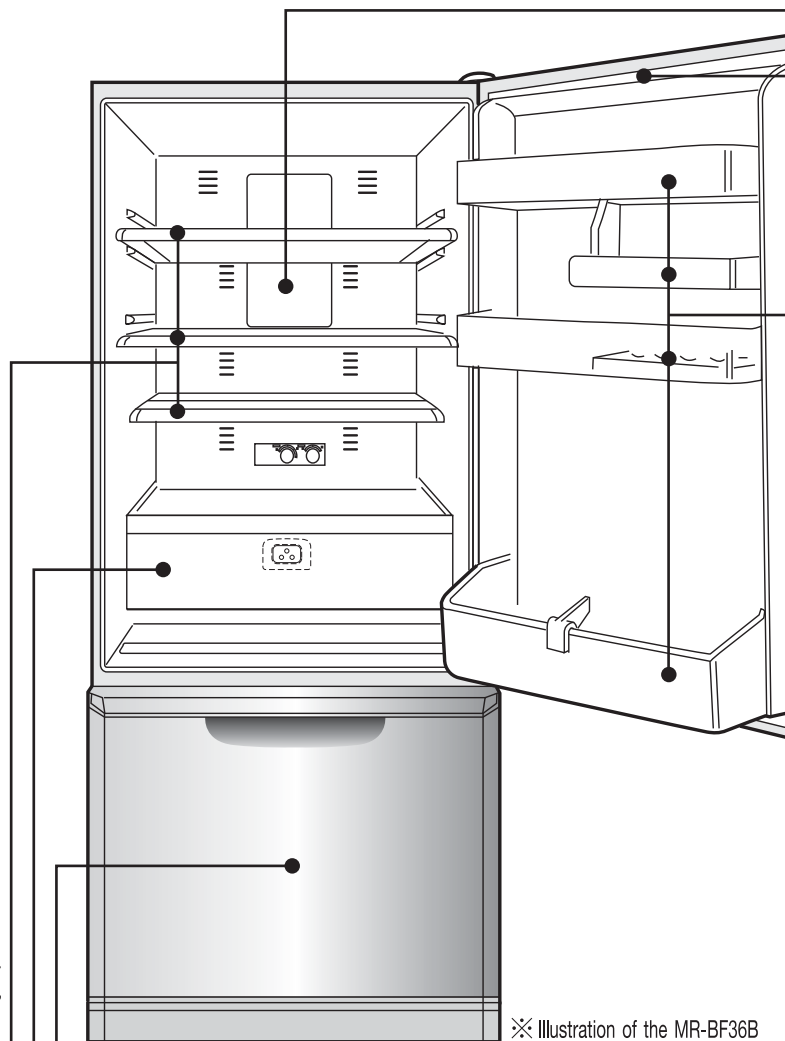

※ Illustration of the MR-BF36B

## Refrigerator Compartment

### Adjustable shelf

Draw forward, pull downward.



### Two-way flexishelf

Draw forward, pull downward.

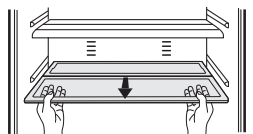

## Sliding Case

Lift the front part and draw out.

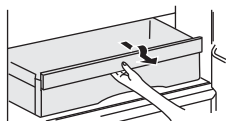

## Liquid-Catching Indentations

Wipe away any dirt, liquid or condensation.

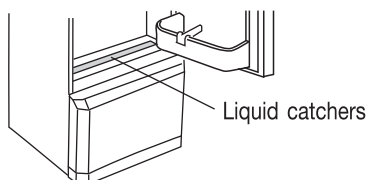

## Freezer Compartment

- ① Open the drawer-door fully and,
- ② Lift up the ice tray and take out.
- ③ Lift up the freezing case (upper) and ice cube box towards you.
- ④ Take out the freezing case (upper), and while slightly lifting up the door draw out and tilt downwards.
- ⑤ Lift up the freezing case (lower) towards you.

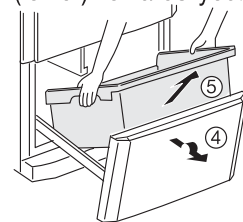
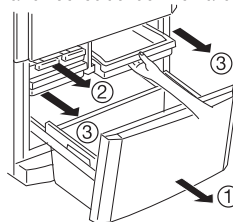

## The back of the refrigerator, and on the floor

- ① Turn the adjustable legs, let it rise above the floor, then move the refrigerator.
- ② Wipe the dirt off the back of the unit, the wall, and the floor. Dust can collect at the back side of the unit and on the floor because of the convection air flow, and it's an area that can easily get sooty dirt.
- ③ Check to make sure there's no water leaking on the floor.

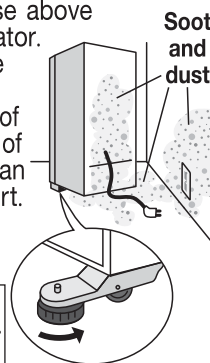

#### Warning

Do not put your hands or feet under the refrigerator. Doing so may cause injury.



# Use reverse procedures to put accessories back in place.

## The door seal strip

If the door seal strip gets dirty, it can be easily damaged and can cause cold air to escape.

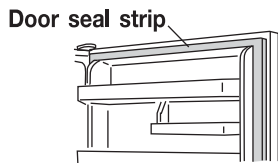

## Free Pockets/Bottle Pockets/Small Items Pocket

- ① Lift upwards holding right and left sides and (the piece is attached quite firmly).
- ② Then draw forwards to remove.
- ③ Make sure that that it is put back on properly.  
(If these accessories are not put back properly, they may fall off and cause injury.)

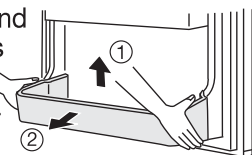

## How to change your refrigerator light bulb

- ① Unplug the electrical plug.
- ② Remove adjustable shelves, Two-way flexishelf.
- ③ While pushing up the tabs at the ▲ mark, pull out.
- ④ Change the inside light bulb.  
● Purchase a 240V 15W glass light bulb (metal cap E-12) from your refrigerator retailer.
- ⑤ After inserting the upper tabs, set in the lower tabs.

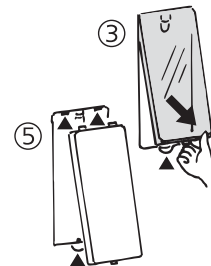

### Warning

If the specified refrigerator bulb is not used, it may cause a fire. Always unplug your refrigerator when changing the light bulb. If you work without unplugging the unit, there is the risk of electric shock or injury. Also, in the worst case, if the refrigerant (gas) is leaking, there may be the risk of ignition or explosion.

## After cleaning accessories, inspect at regular intervals

### Inspect your electrical plug and cord

- ① Unplug the electrical plug from the outlet and inspect.  
Is there any damage or abnormal heat coming from the plug or cord?
- ② Wipe away dust from the plug and around the plug area with a dry cloth.
- ③ Insert the electrical plug fully into the outlet.



### Warning

If dust collects on the electrical plug or cord, it can get damaged and can cause a fire.

## What to do in these situations

### ◆ When there's a power failure.

- Minimize opening/closing of doors and avoid putting in more food.

### ◆ When not in use for a long time.

- Clean the interior after unplugging the refrigerator, and keep the door open for 2 - 3 days to let it get dry.  
※ If not allowed to dry properly, mold and odors can occur, or refrigerant (gas) may leak due to corrosion of the cooling unit.

### ◆ When transporting.

1. Use protective gear (protective gloves).
2. Lay towels under the water discharge outlet and under the back corners of the refrigerator, and place a container or tray on the floor that's about 3 cms high to catch water.  
※ Towels prevent water from spilling on the floor and damage to the floor.
3. Slowly tilt the refrigerator back to an angle of over 30 degrees, discharge water of the evaporator tray through the water discharge outlet (the evaporator tray is not visible from the outside.)  
※ Have 2 or more persons do this work because the unit is heavy.  
※ Avoid having young children or those without confidence do this work.  
Please seek advice from a moving company.
4. With more than 2 persons, calmly and slowly transport the unit by grasping the front side's lower section inner edge and the back side's upper section handle.  
● Do not lay or load on its side (it will cause damage to the compressor.)  
● If you are moving, it won't be necessary to convert the electrical power frequency. (Can use 50 or 60Hz).

Water discharge outlet

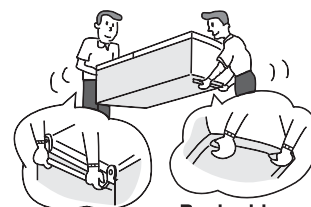
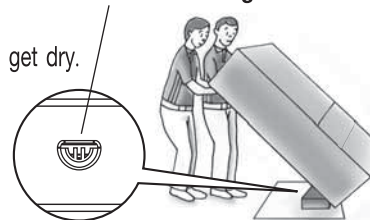

Front side - lower section inner edge

Back side - upper section handle

### ◆ When moving the unit / when changing the direction of the unit.

1. Lift the adjustable legs. **Page 4**
2. Move in a forward or backward direction. ● If moved other than a in forward or backward direction, there's a risk of damaging the floor.
3. When changing the direction of the unit, please use caster wheels or place a protective cloth under the back legs.

### Warning

**Do not damage the refrigerant circuit, do not drive in screws, etc.**

The unit uses a flammable refrigerant, so if the gas leaks out, there is the risk of ignition or an explosion.

# If you think “is this a problem?”

Please check the following points. If the problem cannot be solved, immediately contact the store where you bought the unit.

**If this happens... ➡ Please check this out. ➡ Please do this. This is the reason.**

It doesn't cool at all. ➡ ① Is it getting electrical power? ➡ ① Please check the electrical plug and breaker.

It doesn't cool properly  
It only makes small amounts of ice  
The ice is melting. ➡ ① Is the temperature adjustment set on a left of “MID”?  
② Is it right after installing the unit?  
③ Is there not enough space around the unit, is the sun directly on it, or is the radiation of heat being blocked?  
④ Is the flow of cold air being blocked? Are doors being opened often, or are doors improperly sealed shut?  
➡ ① Please adjust the temperature to “MID” or “COLDER.”  
② It will take about 4~5 hours to cool down. During summer, it may take about 24 hours to make ice.  
③ Please check to see that it's installed properly. **Page 4**  
④ Please check to see that too much food isn't placed in the refrigerator and that the door is properly sealed shut. **Page 5**

Foods get frozen in compartments besides the freezer. ➡ ① Is the refrigerator compartment temperature set at “COLDER”?  
② Are foods with a lot of moisture placed at the back end of the shelf?  
③ Is the ambient temperature less than 5 °C?  
➡ ① Please adjust the refrigerator compartment temperature to “MID.”  
② Please put foods such as tofu, vegetables, fruit, and foods with a lot of moisture or drinks towards the front part.  
③ If the freezer compartment temperature is adjusted to a left of “MID”, foods will be less likely to freeze.

Dew forms on the outside/inside of the fridge  
Frost forms in the freezer compartment  
Water drips on the floor. ➡ ① Are the doors being opened often? Are doors improperly sealed shut?  
② Is it a time of high humidity as in the rainy season?  
➡ ① When the moisture in the air gets cooled, frost or dew forms. Even if the door is just slightly open, frost or dew may form. Also, this dew may sometimes drip onto the floor. **Page 5**  
② There may be times when dew forms temporarily. Please wipe it off with a dry cloth. Also, there may be times when frost forms in the freezer compartment. Please open the door for shorter times.

Doors open easily  
Doors don't close. ➡ ① Is food or a case blocking the door?  
② Is there food caught at the back of the case of a drawer-door? Is the electrical cord caught between the body of the unit and the door?  
③ Does the refrigerator wobble or seem unstable? Are the adjustable legs touching the floor?  
➡ ① Put away items properly so that they don't interfere when closing the door.  
② Remove the item. Please do not let food items, the electrical cord, plastic bags, etc. get in the way.  
③ Bring the adjustable leg down, and raise the front higher, with a slightly raised front, closing doors becomes easier. **Page 4**

The odor bothers me (Food items / ice). ➡ ① Have you put in strong-smelling foods without using a food wrap?  
② Is the water supply tank unclean?  
➡ ① If the smell is strong, the odor-removing device cannot remove it all, so please wrap such items.  
② Please do a regular cleaning maintenance.

I get static noise from the TV, etc. ➡ ① Is the refrigerator installed near a TV?  
② Is the power source for the refrigerator taken from near the antenna cable inlet?  
➡ ① Please set your refrigerator at a distance from TVs, etc.  
② We recommend a single power outlet and that earthing is done.

It's got a loud sound  
It's got sounds that worry me  
The following sounds do not mean there's a problem. ➡ ① The sound suddenly gets louder. The sound changes.  
② There's a “phyoon” sound when I close the door.  
③ Sometimes there are sounds like “shuu” or “plub-plub” (boiling water sound) or “shaaa”(water flowing sound).  
④ When I open the door, there's sometimes a “krik” sound coming from the inside, or a sound like water running.  
⑤ Sometimes there's a “bzzzt” sound like a flying mosquito.  
➡ ① If it is right after installation, or hot out, or if doors are open/closed often, it goes into high-speed operation to chill with greater power.  
② This is the sound of the fan motor starting up.  
③ This is the sound of refrigerant (gas) flowing through.  
④ This creaking sound occurs when warm air enters and the plastic expands.  
⑤ This is the sound of the damper working to adjust the air flow.

The outside of the unit gets hot  
There's air coming from the floor. ➡ This is because there's heat radiating from the sides and top of the refrigerator, there's dew prevention piping and there's a fan below expelling radiating heat. Right after installation or during the summer, especially if it's hot outside (about 50-60 °C), warm air can come out from under the unit. This operation is necessary to keep the unit cool and there is no problem.

If you think “is this a problem?”

# Accessories.

	Model name	MR-BF32B	MR-BF36B	MR-BF43B
	Accessories	Quantity	Quantity	Quantity
Refrigerator compartment	Adjustable shelf	2	3	4
	Two-way flexishelf	1	1	1
	Sliding case (vegetable case)	1	1	1
	Free pocket	2	2	2
	Free egg tray	1	1	1
	Small-Item pocket	-	1	1
	Bottle pocket	1	1	2
	Bottle stopper	1	1	1
Freezer compartment	Ice tray	2	2	2
	Ice cube box	1	1	1
	Freezing case (upper)	1	1	1
	Freezing case (lower)	1	1	1
	Toe grille	1	1	1

■ This appliance is designed for use in countries listed below. No service is available outside of these countries.

MODEL NAME	COUNTRY NAME
MR-BF32B/36B/43B-H	HONG KONG
MR-BF32B/36B/43B-ML	MALAYSIA
MR-BF32B/36B/43B-P	SINGAPORE

## CAUTION

1. This appliance is designed for use in ambient temperature listed below.

MODEL NAME	AMBIENT TEMPERATURE RANGE	CLIMATIC CLASS
MR-BF32B, BF36B, BF43B-P	16 °C ~ 43 °C	T
MR-BF32B, BF36B, BF43B-ML	16 °C ~ 43 °C	T
MR-BF32B, BF36B, BF43B-H	16 °C ~ 38 °C	ST

The internal temperatures could be affected by such factors as the location of the refrigerating appliance, ambient temperature and the frequency of door opening, and, if appropriate, a warning that the setting of any temperature control device might have to be varied to allow for these factors.

2. A rise in temperature of the frozen food during manual defrosting, maintenance or cleaning could shorten the storage life.
3. Food to be frozen is not to be placed in direct contact with food in storage and, if appropriate, that it could be necessary to reduce the quantity to be frozen if freezing every day is anticipated.
4. The electrical power failure for 1-2 hour will only slightly effect the inside temperature. However, open & close of the door results in the temperature loss. In case there is more than 24 hours electrical power failure, the food should be taken out from the fridge.
5. In case you are leaving or there is no food in the fridge for more than 3 weeks, The fridge should be unplugged and cleaned.

# MEMO

MEMO



With low energy

Protect the environment Live well

## Power saving

Refrigerators use the most electricity of all household appliances. Even a little effort can help to save electricity. Let's all try to save power

Are you putting hot items directly into the refrigerator without allowing them to cool first?

Are you opening the doors more often than necessary?

Is the refrigerator cooling too much?

## Tender care inspection

### ● Inspect the refrigerator to get many years of use!



Have you noticed these symptoms?

- The power cord or plug is unusually hot.
- The power cord has a deep cut or is deformed.
- You smell something burning.
- Water is always collecting on the floor under the refrigerator.
- You get shocked when you touch the refrigerator.
- You notice any other abnormality or malfunction.

Stopping use

To prevent an accident or when there is a malfunction, remove the power cord plug from the outlet and be sure to contact your refrigerator retailer for inspections or repairs.

## Customer memo

Convenient information when requesting repairs or service

Purchase date

Year Month Day

Retailer

Telephone number

( )

# 爲了安全請務必遵守

■ 進行錯誤操作時，用以下的顯示來區別說明將要發生的危險及其程度。

## 警告

進行錯誤操作時，可能造成死亡或者重傷的情況

## 注意

進行錯誤操作時，可能造成傷害或者房屋、財產等的損害的情況

■ 圖片記號的含意如下所示。



禁止



絕對不要觸摸



絕對不要分解・修理・改造



絕對不要潑水、不要用水弄濕



絕對不要用濕手觸摸



務必按照指示進行操作



務必連接接地線



務必將電源插頭從插座中拔出

■ 發生異常以及故障時，請立即停止使用，並向「購買冰箱的銷售商店」或者「三菱電機修理窗口・諮詢窗口」諮詢。

## 警告

### 設置時

#### 安放時冰箱的周圍留有空隙

否則冷媒（氣體）  
洩漏時可能滯留，  
導致著火・爆炸。

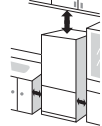

留有空隙

#### 爲了預防地震，將其固定在牢固的牆壁或柱子上

冰箱可能傾倒，  
導致受傷。

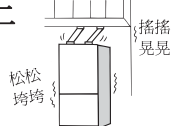

防止傾倒

#### 不要將冰箱設置在室外、接觸水的場所或濕氣較重的場所

否則由于絕緣不良，  
可能導致觸電・火災。



禁止沾水

#### 使用符合規格標籤上指定規格的專用電源插座。規格標籤位於冷藏室的門襯上。

使用延長導線，或於同一插座  
插上過多插頭，會造成過熱或  
引起火警。



第4頁

只使用符合指定規格的電源插座。

#### 如電線損壞，請通知三菱家庭電器服務中心更換。

如電線損壞，可於三菱家庭電器服務中心重新選購電線。請確定所購電線適用於此型號雪櫃。



聯絡服務中心

#### 使電源插頭的電纜線方向朝下，將插頭的插針插到根部

如果反方向插入，則電  
纜線將受到負荷，可能  
導致發熱・著火。



電纜線方向向下

### 關於電源・電源插頭

#### 更換或檢查冰箱照明燈時，拔出電源插頭

否則可能導致觸電・  
受傷。



拔出插頭

#### 不要將電源插頭擠壓在冰箱的背面。不要弄壞電源電纜線

如果進行擠壓、放置重  
物、彎折、捆束，可能  
導致觸電・火災。



禁止

#### 不要使用損壞的電纜線或插頭、插口鬆動的插座

否則可能導致觸電・  
著火。



禁止使用

#### 不要用力拉拔電源插頭的電纜線

否則電纜線可能損壞，導致  
觸電・著火。

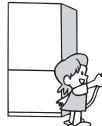

禁止

#### 去除電源插頭的灰塵

否則可能引起絕緣  
不良，導致火災。



去除灰塵

#### 不要用濕手插拔電源插頭

否則可能導致  
觸電。



禁止濕手觸摸

## 注意

### 設置・搬運

#### 在地面牢固且水平的場所通過調整腳座牢牢固定

否則冰箱可能移動，  
導致受傷。



水平安放

#### 進行搬運時，抓住搬運用把手

如果抓住其他  
部分，可能導致  
受傷。



抓住搬運用把手

### 關於使用的注意事項

#### 不要強行放入太多食品 不要用力拉出隔板架

否則食品可能落  
下，導致受傷。



禁止

#### 不要用濕手接觸冷凍室的食物或容器





















否則可能  
導致凍傷。

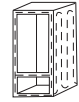

禁止濕手觸摸







## 警告

### 關於使用的注意事項

<p><b>不要將裝水的容器放置在冰箱上面</b></p> <p>如果水接觸到電子零件，可能導致觸電・火災。</p>   <p style="text-align: right;">禁止沾水</p>	<p><b>不要在冰箱內使用電子產品</b></p> <p>如果冰箱內發生冷媒（氣體）洩漏，則可能由于電子零件接點的火花導致著火・爆炸。</p>   <p style="text-align: right;">禁止</p>	<p><b>不要放入具有揮發性容易著火的物品</b></p> <p>如果放入汽油、化妝品、美髮劑，則可能導致著火・爆炸。</p>   <p style="text-align: right;">禁止儲藏</p>
<p><b>不要在冰箱的上面放置物品</b></p> <p>否則物品可能由于開關冰箱門而落下，導致受傷。</p>   <p style="text-align: right;">禁止</p>	<p><b>不要在冰箱內保存藥品或化學樣品</b></p> <p>不要在家用冰箱中保存必須進行嚴格管理的物品。</p>   <p style="text-align: right;">禁止儲藏</p>	<p><b>冰箱照明燈必須使用指定的額定產品</b></p> <p>如果使用非指定的產品，則可能導致火災。</p>  <p style="text-align: center;">第9頁</p> <p style="text-align: right;">使用指定產品</p>
<p><b>不要騎在冰箱門或拉門把手（把手）上，不要站在抽屜式冰箱門上</b></p> <p>否則冰箱可能傾倒，導致受傷。</p>   <p style="text-align: right;">禁止</p>	<p><b>不要損壞冰箱的冷媒回路（配管），不要打入螺絲等</b></p> <p>本冰箱使用可燃性冷媒（氣體），因此可能導致著火・爆炸。</p>   <p style="text-align: right;">禁止</p>	<p><b>如果發現氣體洩漏，不要接觸冰箱，立即打開窗戶讓空氣流通</b></p> <p>否則可能由于電子接點的火花，導致爆炸・火災。</p>   <p style="text-align: right;">進行換氣</p>
<p><b>不要進行水洗，不要打翻湯汁</b></p> <p>如果接觸水・湯汁，則可能導致觸電・火災。請立即擦拭幹淨。</p>   <p style="text-align: right;">禁止澆水</p>	<p><b>不要在附近使用可燃性噴霧劑</b></p> <p>否則可能由于電子接點的火花，導致著火・火災。</p>   <p style="text-align: right;">禁止使用</p>	<p><b>不要在小屋或車庫中使用</b></p> <p>否則小動物可能會損壞電子配線，導致觸電・火災。</p>  <p style="text-align: right;">禁止使用</p>

● 為了安全請務必遵守



### 關於故障・長期保管

<p><b>損壞冷媒回路（配管）時，不要接觸冰箱，避免使用火焰，打開窗戶讓空氣流通</b></p> <p>損壞冷媒回路時，請向銷售商店諮詢。</p>   <p style="text-align: right;">進行換氣</p>	<p><b>發生異常時（聞到焦臭味等），拔下電源插頭，中止操作</b></p> <p>如果在異常狀態下繼續操作，則可能導致觸電・火災。</p>   <p style="text-align: right;">拔出插頭</p>	<p><b>不要進行分解・修理・改造</b></p> <p><b>不要在零件損壞的狀態下進行使用</b></p> <p>否則可能導致受傷・觸電・火災。</p>   <p style="text-align: right;">禁止分解</p>
<p><b>進行保管時如果擔心幼兒被困在冰箱裏，則用力拉冰箱門軟壓條並將其拆下</b></p> <p>如果被困在冰箱裏，則十分危險。</p>   <p style="text-align: right;">拆下軟壓條</p>	<p><b>長時間不使用時，拔下電源插頭，然後打開冰箱門進行乾燥。</b></p> <p>乾燥不充分時，可能由于冷卻機腐蝕引起冷媒（氣體）洩漏，導致著火・爆炸。</p>  <p style="text-align: right;">進行乾燥</p>	<p><b>進行廢棄時，將冰箱交付給銷售商店或地方政府</b></p> <p>如果放置不管，可能發生冷媒（氣體）洩漏，並由于火焰導致著火・爆炸。</p>  <p style="text-align: right;">交付</p>

- 兒童不宜操作本冰箱，體弱者若無人監護亦不可操作，以確保操作安全。
- 請注意不要讓兒童在冰箱玩耍。
- 除非是得到適當人仕監督或指導如何操作此電器，以確保使用者的安全，否則此電器並不預期體格、知覺、精神上不足的人仕或缺乏相關經驗及知識人仕(包括小童)使用。小童必須受到監管以確保其不會玩弄此電器。

## 注意

### 關於使用的注意事項

<p><b>不要在冷凍室內放置瓶類物品</b></p> <p>否則瓶內物品可能由于結冰而碎裂，導致受傷。</p>   <p style="text-align: right;">禁止儲藏</p>	<p><b>不要吃變味、變色的食品</b></p> <p>否則可能導致食物中毒或生病。</p>   <p style="text-align: right;">禁止</p>	<p><b>開關冰箱門時</b></p> <ul style="list-style-type: none"> <li>● 其他人正在接觸冰箱時不要開關冰箱門。</li> <li>● 關門時不要將手指放在抽屜式冰箱門上面</li> <li>● 不要讓下面的抽屜夾住腳（可能夾傷腳趾）</li> <li>● 不要用力開關冰箱門（否則可能引起食品落下，導致受傷）</li> </ul>   <p style="text-align: right;">禁止</p>
<p><b>不要將手・腳放在冰箱底下</b></p> <p>否則可能由于鐵板等導致受傷。</p>   <p style="text-align: right;">禁止接觸</p>	<p><b>關閉冰箱門時抓住把手</b></p> <p>關閉冰箱門時請注意不要夾傷手指。否則可能導致受傷。</p>   <p style="text-align: right;">抓住把手</p>	

# 從安放冰箱到開始操作

從安放冰箱到開始操作

## 1 設置

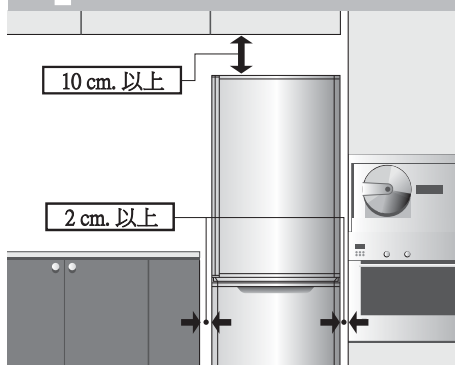

### 安放場所為

無太陽直射、遠離熱氣、通風良好的場所

防止冷凍能力下降，節約電費

濕氣較少的場所

防止生鏽、觸電、火災

牢固且水平的場所

防止振動・噪音・冰箱門半開・冰箱門下垂

●如果地面材料容易使冰箱的腳座沈降，請在下面鋪設牢固的墊板。

(防止由于重量或熱量導致的變形・變色)

遠離其他機器的場所

防止電視產生雜音或圖像失真

### 在周圍預留散熱空間

左右預留2cm以上的空間頂部預留10cm以上的空間以及背部預留5cm以上的空間。

由於從頂部、側面及背部散熱。

因此冰箱機體外側將變熱。

剛剛開始使用時或夏季使用時溫度可能達到約50~60℃以上。

### 警告

不要堵塞冰箱的通氣口或周圍的散熱空隙。否則冷媒(氣體)洩漏時可能滯留，導致著火・爆炸。

## 2 接通電源 接地

為了盡快制冷，請在設置完冰箱後立即接通電源。



使用符合規格標籤上指定規格的專用電源插座。規格標籤位於冷藏室的門襯上。

為了防止觸電事故的發生，我們建議您進行接地

特別是安放在未鋪地板的房間・洗衣房、地下室等濕氣較重的場所時，請安裝接地以及漏電斷路器。

### 配有接地端子時

將接地線連接在接地連接螺絲(Ⓧ記號)上，安裝接地端子。另外，請向購買冰箱的銷售商店等求購接地線(市售的銅線直徑1.6mm)。

### 未配接地端子時

委托購買冰箱的銷售商店，進行接地工事。(D類接地工事・有償)

### 設置在水氣特別多的場所時

除了接地以外，法令要求必須設置漏電斷路器。請向購買冰箱的銷售商店諮詢。

### 關於不得連接的場所

- 水管・煤氣管(存在觸電・爆炸的危險)
- 電話線或避雷針的接地(落雷時存在危險)

## 3 調整・固定

向箭頭方向旋轉，將調整腳座調下來抵住地面

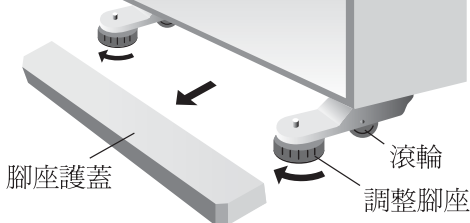

※出貨時腳座護蓋被包裝在冷藏室內。

旋轉調整腳座，使其抵住地面，擡高前滾輪進行固定

防止振動・噪音・移動・冰箱門半開

### 注意

固定不完全時，冰箱可能移動，導致受傷。

- 如果保持左右水平，使前側稍許偏高，則更容易關門，可以防止冰箱門半開。

### 不能通過調整腳座調整傾斜時

如果安放在房間角落等，則有時後部的一個腳座可能下沉，造成冰箱傾斜。此時，請在後部放置一台滾輪(有償)或牢固的墊板，並進行調整。(通常墊板的標準厚度為2~3mm。)求購一台滾輪，請向購買冰箱的銷售商店諮詢。型號 MRPR-03CS

### 關於冰箱門的傾斜

如果設置場所不水平，或者幾天後由于食品的重量導致腳座下沉，使得冰箱門看上去有點下降。(根據食品的數量不同，有時食品的重量可能超過100kg)請將調整腳座向圖片所示的方向旋轉，進行再調整。

冰箱門的左側下降時

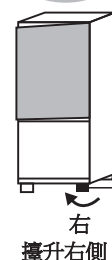

冰箱門的右側下降時

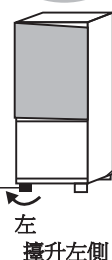

## 4 地震的預防措施

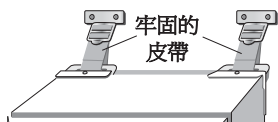

將牢固的皮帶穿過背面上部的手柄(2處)，將其固定在牆壁或柱子等牢固的場所

### 警告

否則冰箱可能傾倒，導致受傷。

請向購買冰箱的銷售商店求購冰箱用防止傾倒皮帶(另售)。

型號：MRPR-02BL

# 溫度的調節方法

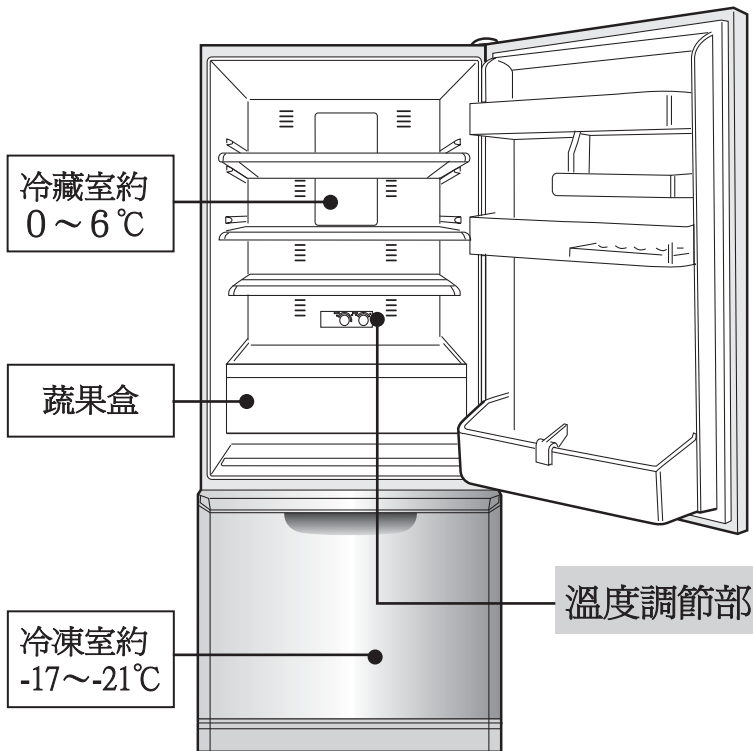

※ 圖片為MR-BF36B

※ 顯示溫度為冷藏室、冷凍室的溫度調節對准「中」的位置，周圍溫度為30°C，不放入食品並關上冰箱門，溫度穩定時，在冰箱內中央偏下的位置測量得到的溫度基準。

## 請求

### 為了盡快制冷

由于制冷需要時間，因此請盡早接通電源。通常制冷需要約4~5小時。

設置後，即使立即接通電源，也不會損壞機械。

- 放置食品時注意在食品之間保留空隙。
- 在冰箱充分冷卻後再放入沒有冷卻的食品或冰淇淋。
- 盡量減少冰箱門的開關次數，縮短開關時間。

特別在夏季炎熱時，到最初的冰塊成形有時需要約24小時。

### 關於無氟冰箱

不要損傷冰箱的冷媒回路（配管），不要打入螺絲等

無氟冷媒（氣體）雖然為可燃性氣體，但是冷媒回路被密封，通常不會漏出。

#### 警告

萬一冷媒回路受到損傷

1. 避免使用火焰或電子產品
2. 打開窗戶，讓空氣流通

此後，請聯系購買冰箱的銷售商店。

### 關於冰箱門警報

通過冰箱門警報（“吡吡”的聲音）的鳴響次數，表示以下的狀態。

4次※ 冷藏室・冷凍室中的某一個冰箱門打開了1分鐘以上。請關閉冰箱門。

※ 冰箱門打開後每過1分鐘鳴響4次，過5分鐘後則連續鳴響。請確認是否發生冰箱門半開、食品卡住（軟壓條・盒的後側）。

- 請每月檢查一次。
- 關閉冰箱門後，警報仍然鳴響時，請向購買冰箱的銷售商店諮詢。

制冷過強時

從「中」位置  
提高2~3°C

一般設置為  
「中」的位置

想要增強制冷時

從「中」位置  
降低2~3°C

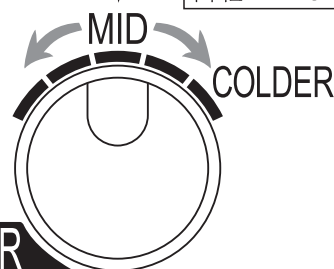

## REFRIGERATOR

- 蔬果盒內的溫度將隨著改變冷藏室的溫度調節的同時發生變化。

制冷過強時

從「中」位置  
提高2~3°C

一般設置為  
「中」的位置

想要增強制冷時

從「中」位置  
降低2~3°C

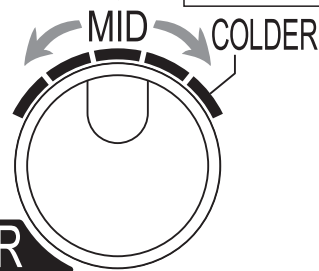

## FREEZER

## 節約用電的訣竅

### 節約用電的方法

- 放置食品時注意在食品之間保留空隙。
- 較熱的物品在冷卻後再放入。
- 盡量減少冰箱門的開關次數，縮短開關時間。
- 關閉冰箱門時，注意不要夾住食品・塑料袋・電源電纜線等。

即使只有很小的冰箱門空隙，也有可能結霜或結露，導致不能制冷。或者有時可能發生滴水。

### 儲存的訣竅



擦拭



包裹

防止乾燥或變味。



# 冷藏室

● 冷藏室

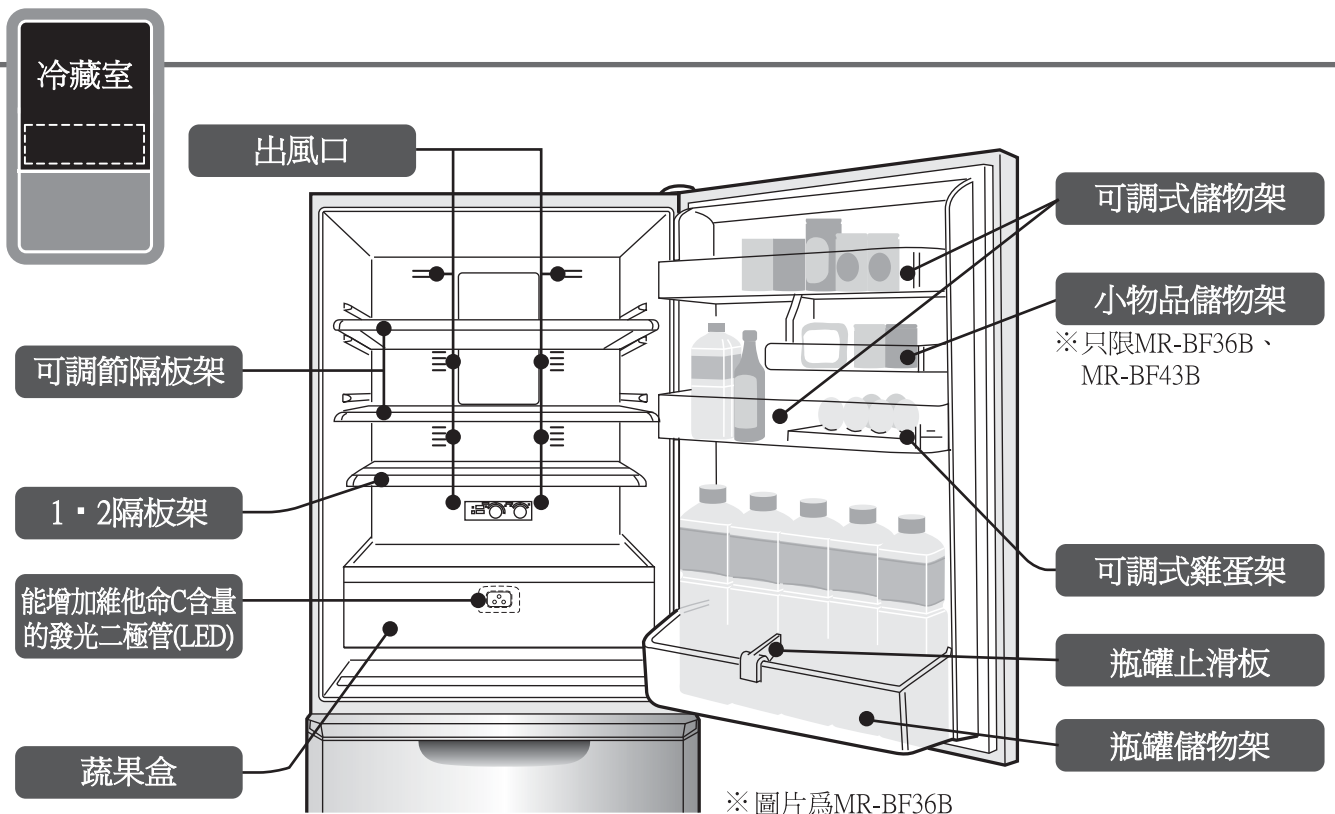

## 可調節隔板架

調節隔板架的位置，調節儲存量！

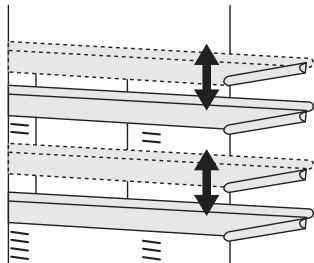

請拉出隔板架並拆下，將其安裝在您喜歡的位置。

## 1·2隔板架

①. 拉出

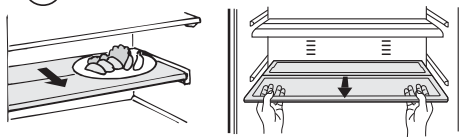

②. 壓入

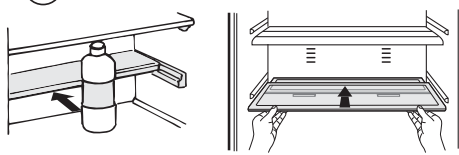

## 可調式雞蛋架

雞蛋架與小物品儲物架將其反置，可以用于2個方向。

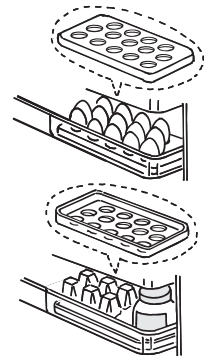

## 請求

放入食品時，不要讓食品寬度超出隔板架  
瓶罐儲物架前列上不要放置不能完全放到底下的瓶類。

- 可能導致冰箱門半開或者瓶類損壞。

不要在蔬果盒的外側放置食品的狀態下  
關閉冰箱門  
蔬果盒必須牢牢固定



儲物架的外側不要放置市售的盒類等

- 否則可能發生冰箱門半開導致制冷效果變差，或者發生食品跌落導致受傷，從而損壞盒。
- 不要讓市售的盒類堵塞在出風口上。



## 通知

食品凍結時

- 周圍溫度為 5℃ 以下，將冷藏室的溫度調節對准「弱」，則變得難以制冷。
- 水份較多的食品或飲料，請使其遠離出風口附近，放置在隔板架的外側。

# 蔬果盒 · 冷凍室

## 蔬果盒

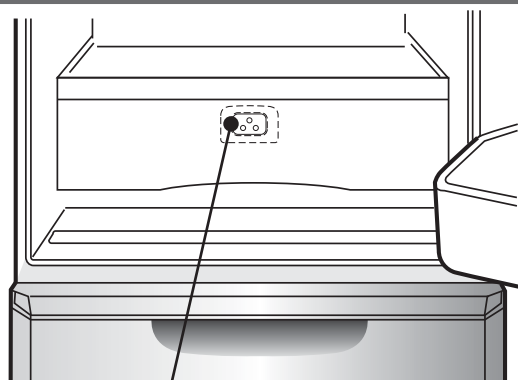

能增加維他命C含量的發光二極管(LED)

### 能增加維他命C含量的發光二極管(LED)

蔬果室內安裝了橙色LED，所發出的光線可引發光合作用，從而增加蔬果的維他命C含量，保持蔬果的新鮮度及延長其壽命。

LED能放射肉眼可看見的橙色光線，光線可穿過透明的蔬果盒或膠袋。無論機門關閉或開啓，它依然會持續運作。

### 請求

不要在蔬果盒的下方放置高度較高的物品

- 可能損壞食品或蔬果盒。
- 拆下蔬果盒進行使用，則蔬果盒將乾燥。

### 通知

● 用保鮮膜包裹蔬果或水果，則可以長時間保鮮。

**切勿拆除、修理、改裝或調校LED。**

- 這樣可能會損壞LED的操作。
- 如果LED損壞或不能正常操作，切勿自行調校或修理，請聯絡維修中心。

### 使用貼士

- 將蔬果放進雪櫃前，請以錫紙或保鮮紙包裹水果及蔬菜，以保持食物新鮮。
- 將蔬果保存在透明容器內或以錫紙或保鮮紙包裹，讓LED的橙色光線直接照射到蔬果上。
- 只要是含有葉綠素成份的綠色蔬果，例如椰菜，都會產生光合作用及增加維他命C含量。光合作用的效果，要視乎蔬果的新鮮度及種類而定。

● 蔬果盒 · 冷凍室

## 冷凍室

塑膠製冰格

冰塊儲存盒

冷凍盒(上)

冷凍盒(下)

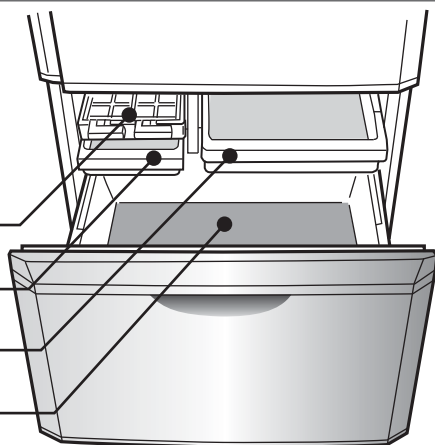

### 製冰

1. 請將水倒入製冰格中的每一格達滿水線。將製冰格完全推入製冰格支架。若您加的水太多，冰塊將不容易從製冰格中取出。
2. 當製冰完成後，請旋轉支桿直到冰塊落入冰塊儲存盒內。

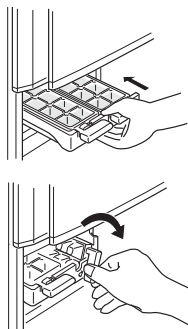

### 請求

請將食品放置在冷凍盒側面的標籤紅線以下的位置。

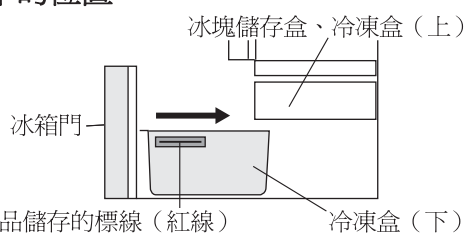

- 關閉冰箱門時，由于食品頂住導致冰箱門半開，或者冰箱內結霜導致不能制冷等原因，可能導致故障。
- 可能損壞食品或冷凍盒、冰塊儲存盒。

### 通知

- 用礦泉水等礦物質較多的水制作的冰塊有時會出現白色沈澱物(白色結晶)。這是礦物質成分的結晶，對人體無害。
- 長時間保持儲存冰塊狀態，則可能冰塊與冰塊結在一起，或者冰塊變小。(此現象稱之為升華)
- 打碎結在一起冰塊時可能弄傷手，請注意。

### 請求

- 若您嘗試直接在冰塊儲存盒中製冰，則冰塊儲存盒可能會破裂。

# 附屬品的拆下方法與保養

## 保養之前

### 拔出電源插頭

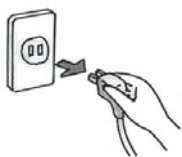

**警告**  
如果不拔下，則可能導致觸電。

再次將電源插頭插入插座時，請等待10分鐘以上後再插入。如果立即插入，則機械將不能運作。

## 保養的方法

- 用軟布蘸了溫水進行擦拭，或者拆下進行水洗。
- 難以除去的污垢使用稀釋的廚房用清洗劑（中性），並用濕布擦拭乾淨。特別是如果放任油污不管，則塑料可能碎裂。
- 將清洗劑擦拭乾淨。
- 使用化學抹布時，請遵守附屬的注意事項。



### 請求

- 請不要使用鹼性／弱鹼性廚房用清洗劑・拋光粉・肥皂粉・酒精・汽油・稀釋液・石油・酸・洗碗刷・熱水等。否則將導致塑料零件如冰箱門的把手・蓋子・盒等碎裂，或者冰箱門或塗裝面損壞。

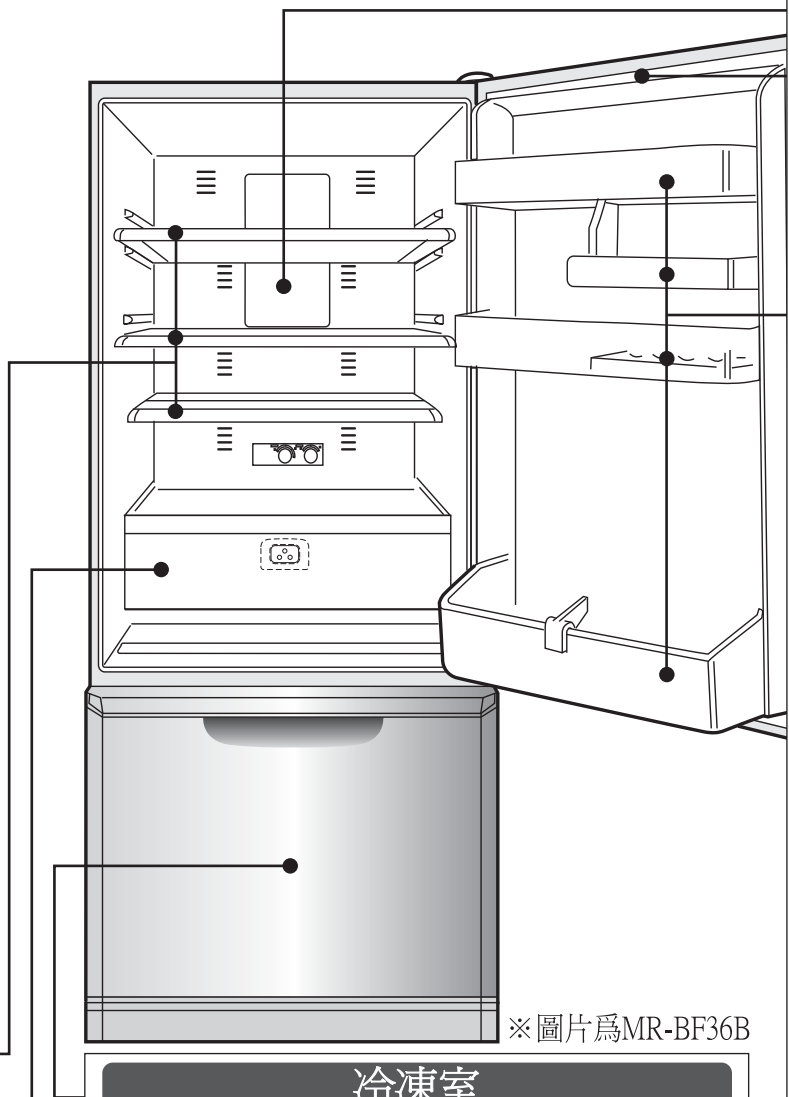

※圖片為MR-BF36B

## 冷藏室

### 可調節隔板架

抽出，向下拉出。



### 1・2隔板架

抽出，向下拉出。

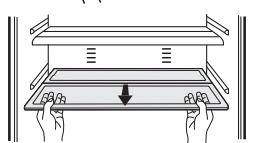

## 蔬果盒

抓住外側並取出。

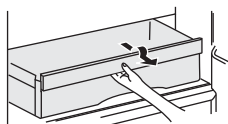

## 排水盤凹部

擦拭污垢、汁液、結露。

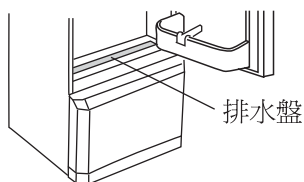

排水盤

## 冷凍室

- ① 將冰箱門完全拉出
- ② 抓住塑膠製冰盒並取出。
- ③ 將冷凍盒（上）、冰塊儲存盒向外側擡起。
- ④ 取出冷凍盒（上），稍微擡起冰箱門並抽出，然後傾斜。
- ⑤ 將冷凍盒（下）向外側擡起。

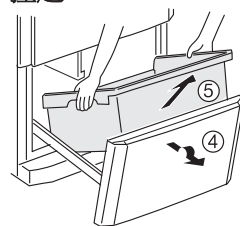
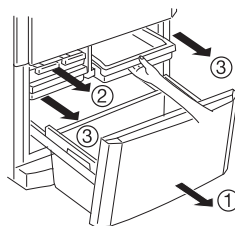

## 冰箱的背面・地面

- ① 旋轉調整腳座，使腳座離開地面，然後移動冰箱。
- ② 擦拭冰箱背面、牆壁、地面的污垢。背面或地面由于空氣對流，容易積累灰塵，或者出現黑色污垢。
- ③ 確認地面是否漏水。

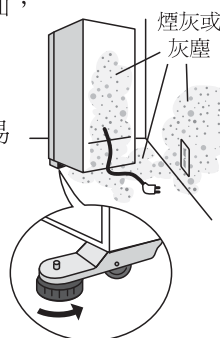

### 注意

不要將手、腳放入冰箱下面。否則可能導致受傷。

按照與拆下方法相反的順序進行安裝。

### 冰箱門軟壓條

如果弄髒，則容易損壞，可能導致冷氣洩漏。

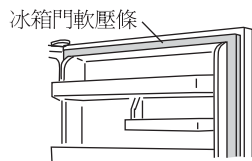

### 可調式儲物架・瓶罐儲物架・小物品儲物架

- ① 左右同時拿起（安裝比較牢固。）
- ② 向外側拉出並拆下。
- ③ 確認已經安裝牢固。（如果安裝不充分，則容易脫落，可能導致受傷）

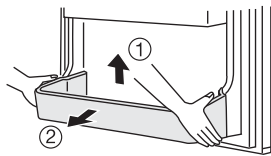

### 更換冰箱照明燈

- ① 拔出電源插頭
- ② 拆下可調節隔板架、1・2隔板架。
- ③ 一邊將 ▲ 標誌的旋鈕向上按，一邊拉出。
- ④ 更換冰箱照明燈。
  - 請向雪櫃經銷商選購 240V 15 W 的玻璃燈泡（金屬帽 E-12）。
- ⑤ 插入上側的旋鈕部後，套上下側的旋鈕部。

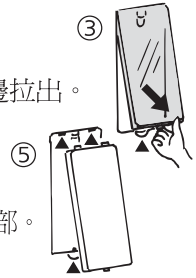

#### 警告

冰箱照明燈如果使用非指定產品，則可能導致火災。  
更換冰箱照明燈時務必拔出電源插頭  
如果作業時不拔下插頭，則可能導致觸電或受傷。  
另外，萬一冰箱內洩漏冷媒（氣體），則可能導致著火・爆炸。

## 保養之後／定期進行

### 檢查電源插頭與電纜線

- ① 將電源插頭從插座上拔下，然後進行檢查
  - 電源插頭或電纜線是否損傷或者異常發熱。
- ② 擦去電源插頭與其周圍的灰塵，用乾布擦拭
- ③ 將電源插頭牢牢插入插座內



#### 警告

如果電源插頭或電纜線損傷，或者積累灰塵，則可能導致火災。

## 安全建議

### ◆ 停電時

- 減少開關冰箱門的次數，避免儲藏新的食品。

### ◆ 長時間不使用時

- 清潔時拔下電源，然後清潔冰箱，打開冰箱門2~3天時間進行乾燥。
  - ※ 乾燥不充分時，可能導致黴菌、氣味，以及可能由于冷卻機腐蝕導致冷媒（氣體）洩漏。

### ◆ 搬運

1. 佩戴保護工具（手套）
2. 在排水口的下面以及冰箱的背面下面的角部墊上毛巾，在上面放置承水用的高度3cm左右的容器或托盤等
  - ※ 毛巾是用來防止水溢出到地面，或防止地面損傷的。
3. 慢慢向後方傾斜約30度以上，從背面下部的排水口排出蒸發皿內的水（從外部看不見蒸發皿。）
  - ※ 冰箱較重，請由2人以上進行作業。
  - ※ 幼童或體弱者請不要進行作業，並諮詢專業搬運公司等。
4. 請由2人以上抓住前面下部內側與背面下部的手柄，慢慢進行搬運
  - 不要橫置冰箱。（否則可能導致壓縮機故障）
  - 搬家時無需進行頻率的切換（50/60Hz通用）

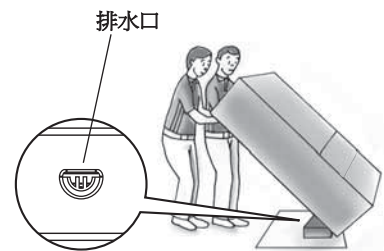

### ◆ 移動時・改變方向時

1. 擡升調整腳座 **第4頁**
2. 在前後方向進行移動 ● 在前後方向以外的方向上進行拖拽，則可能損傷地面。
3. 更改方向時，請在滾輪以及後部的腳座下面鋪設保護地面用的布等，然後再改變方向。



#### 警告

不要損壞冰箱的冷媒回路，不要打入螺絲等  
本冰箱使用可燃性冷媒，因此氣體洩漏時，可能導致著火・爆炸。

# 認為可能發生故障時

請檢查以下的情況，  
如果冰箱狀態依然不良時，  
請立即聯系購買冰箱的銷售商店。

發生這樣的情況時 ➡ 請確認以下事項。

➡ 請如此操作。這樣操作的原因如下所示。

完全不能制冷

➡ ① 電源是否接通。

➡ ① 請確認電源插頭或斷電器。

制冷效果不佳  
制冰量減少  
冰塊融化



➡ ① 溫度調節是否對准「弱」。  
② 不是在安放之後的短時間內。

➡ ① 請將溫度調節對准「中」或者「強」。  
② 制冷需要約4~5小時，夏季則有時結冰需要約24小時。

➡ ③ 是否由于周圍沒有空隙，或者陽光直射等原因，妨礙了散熱。  
④ 是否妨礙了冷氣的流動。另外是否頻繁打開冰箱門，或者處於冰箱門半開狀態。

➡ ③ 請確認冰箱是否正確安放。  
第4頁  
④ 請確認食品是否放入過多，或者冰箱門是否半開等。  
第5頁

冷凍室以外的食品發生凍結



➡ ① 冷藏室的溫度調節是否對准「強」。  
② 是否將水份較多的食品放置在隔板架的內側。  
③ 冰箱周圍溫度是否為5°C以下。

➡ ① 請將冷藏室的溫度調節對准「中」的位置。  
② 請將豆腐・蔬菜・水果等水份較多的食品或飲料放置在外側。  
③ 如果將冷藏室的溫度調節對准「弱」，則將變得難以制冷。

外側或冰箱內結露  
冷凍室結霜  
地面滴水



➡ ① 是否頻繁打開冰箱門，或者冰箱門是否半開。  
② 是否是雨天等濕度較高的時節

➡ ① 如果空氣中的水分被冷凍，則會結霜或結露。即使冰箱門只出現很小的空隙，也有可能結霜或結露。另外結露有時可能垂到地面上。  
第7頁  
② 有時可能暫時發生結露。請用乾布擦拭。另外冷凍室容易結霜。將縮短打開冰箱門的時間。

冰箱門容易打開  
冰箱門關不上

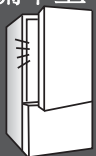

➡ ① 冰箱門是否頂住了食品或盒子。是否放入太多的食品。  
② 抽屜式冰箱門的盒內側是否掉落食品，或者冰箱機體和冰箱門之間是否卡住電源電纜線。  
③ 安放冰箱時是否有鬆動。調整腳座是否抵住地面。

➡ ① 關閉冰箱門時，請注意不要頂住其他物品。  
② 請拿走頂住的物品。請不要讓食品・電源電纜線・塑料袋等卡住冰箱門。  
③ 放下調整腳座，擡高外側，使前側稍許偏高，則更容易關門。  
第4頁

氣味難聞  
(食品・冰塊)

➡ ① 氣味較重的食品是否沒有包裹保鮮膜就放入冰箱  
② 製冰格是否弄髒。

➡ ① 如果氣味較重，依靠脫臭裝置不能完全排除氣味，因此請包裹保鮮膜。  
② 請定期進行清潔。

電視等有雜音

➡ ① 是否在電視等附近設置冰箱。  
② 是否在電視天線的接入口附近連接冰箱的電源。

➡ ① 設置冰箱時，請遠離電視等機器。  
② 我們建議電源單獨接地。

噪音較大發出異常聲音以下的聲音不是異常



➡ ① 聲音突然變大。音色發生變化。  
② 關閉冰箱門時發出“啾啾”的聲音。  
③ 常常發出“啾~”、“破括破括(沸騰的聲音)”或“喇”(水流動的聲音)的聲音。  
④ 打開冰箱門時，冰箱內常常發出“咻唏”的聲音或水滴下的聲音。  
⑤ 常常發出類似蚊子“嗡嗡”叫的聲音。

➡ ① 安放過後短時間內，天氣較熱時，如果開關冰箱門較頻繁，將切換到高速運轉，進行強力制冷。  
② 風扇馬達開始運轉的聲音。  
③ 冷媒(氣體)流動的聲音。  
④ 冰箱內進入暖空氣，塑料膨脹後發出的吱吱的響聲。  
⑤ 調節風量的節氣閥開始運作的聲音。

外側變熱  
地面有風



➡ 因為冰箱的側面或頂部設有散熱・防止結露供水管，另外下面設有促進散熱的風扇。安放過後短時間內，特別是夏季外側會變熱(約50~60°C)，從冰箱下面會吹出暖風。這是為了制冷進行的必須動作，並不是異常。

認為可能發生故障時

# 配件

型號名稱		MR-BF32B	MR-BF36B	MR-BF43B
配件		數量	數量	數量
冷藏室	可調節隔板架	2	3	4
	1·2隔板架	1	1	1
	蔬果盒	1	1	1
	可調式儲物架	2	2	2
	可調式雞蛋架	1	1	1
	小物品儲物架	-	1	1
	瓶罐儲物架	1	1	2
	瓶罐止滑板	1	1	1
冷凍室	塑膠製冰格	2	2	2
	冰塊儲存盒	1	1	1
	冷凍盒（上）	1	1	1
	冷凍盒（下）	1	1	1
	腳座護蓋	1	1	1

型號名稱	國家
MR-BF32B/36B/43B-H	香港
MR-BF32B/36B/43B-ML	馬來西亞
MR-BF32B/36B/43B-P	新加坡

## 注意

1. 這電器適用於以下列出的環境溫度使用。

型號	使用器具的環境溫度範圍	氣候類型
MR-BF32B, BF36B, BF43B-P	16 °C ~ 43 °C	熱帶
MR-BF32B, BF36B, BF43B-ML	16 °C ~ 43 °C	熱帶
MR-BF32B, BF36B, BF43B-H	16 °C ~ 38 °C	亞熱帶

內部溫度會受製冷電器的存放位置、周遭環境的溫度及櫃門打開的頻率而影響。

- 因此調校溫度掣時應對應上述因素而作適當的調整。
- 如用人手控制除霜、維修或清潔雪櫃會令冷藏食物的溫度提高，從而縮短食物的儲存時間。需冷藏的食物不應直接存放於冰格內，若需要每天都急凍食物，應將存放的數量減少。
- 停電 1 至 2 小時只會輕微影響內部溫度，但開關櫃門會令冷氣流失，溫度上升。若停電超過 24 小時，應移走雪櫃內的食物。
- 如果你會離家而雪櫃將會超過 3 星期不存放食物，請將電源線拔掉及清潔雪櫃。

# 備忘



耗電量低  
保護環境，安居樂業

## 節約能源

雪櫃耗電量為家庭電器之冠。  
齊心協力，減少耗電。

您有將熱騰騰的食物直接放進雪櫃嗎？

您有經常無故打開雪櫃嗎？

雪櫃是否過冷？

## 小心檢查

● 定期檢查，延長雪櫃壽命！



您有發現這些徵狀嗎？

- 電線或插頭不尋常地發熱。
- 電線破損或變形。
- 發出焦味。
- 雪櫃底下經常積水。
- 觸摸雪櫃時觸電。
- 發生其他不尋常或失靈現象。

停止使用

雪櫃失靈時，為防意外發生，須將電線插頭拔掉，並聯絡雪櫃經銷商，安排檢查維修。

## 顧客備忘

要求維修服務所需資料

購買日期

年 月 日

經銷商

電話

( )



# MITSUBISHI ELECTRIC CORPORATION

HEAD OFFICE : TOKYO BUILDING 2-7-3, MARUNOUCHI, CHIYODA-KU, TOKYO 100-8310, JAPAN

PHONE: +81 (3) 3218-2111

<http://Global.MitsubishiElectric.com>



## 三菱電機株式会社

總公司：〒100-8310 日本東京都千代田區丸之內2-7-3 (東京大廈)

電話：+81 (3) 3218-2111

<http://Global.MitsubishiElectric.com>

---

SOLE AGENT in Hong Kong

MITSUBISHI ELECTRIC RYODEN AIR-CONDITIONING  
& VISUAL INFORMATION SYSTEMS(HONG KONG)LTD.

7/F., Manulife Tower, 169 Electric Road, North Point, Hong Kong.

Tel: (852) 2510 1505

Fax: (852) 2510 0463

香港總代理

三菱電機菱電空調・影像設備(香港)有限公司

香港北角電氣道169號宏利保險中心7樓

電話: (852) 2510 1505 傳真: (852) 2510 0463

---

SOLE AGENT in Singapore

MITSUBISHI ELECTRIC ASIA PTE LTD

307, ALEXANDRA ROAD

# 05-01/02

MITSUBISHI ELECTRIC BUILDING

SINGAPORE 159943

Head Office: Tel. (65) 6473-2308

---

SOLE AGENT in Malaysia

MELCO SALES MALAYSIA SDN. BHD. (CO.NO.:11098W)

LOT 11, JALAN 219,

PO BOX 1036,

46860, PETALING JAYA,

SELANGOR DARUL EHSAN,

MALAYSIA.

Head Office: Tel. (603) 7955-2088 (10 lines)

---