



## Fatal1ty Story

---

Who knew that at age 19, I would be a World Champion PC gamer. When I was 13, I actually played competitive billiards in professional tournaments and won four or five games off guys who played at the highest level. I actually thought of making a career of it, but at that young age situations change rapidly. Because I've been blessed with great hand-eye coordination and a grasp of mathematics (an important element in video gaming) I gravitated to that activity.

### GOING PRO

I started professional gaming in 1999 when I entered the CPL (Cyberathlete Professional League) tournament in Dallas and won \$4,000 for coming in third place. Emerging as one of the top players in the United States, a company interested in sponsoring me flew me to Sweden to compete against the top 12 players in the world. I won 18 straight games, lost none, and took first place, becoming the number one ranked Quake III player in the world in the process. Two months later I followed that success by traveling to Dallas and defending my title as the world's best Quake III player, winning the \$40,000 grand prize. From there I entered competitions all over the world, including Singapore, Korea, Germany, Australia, Holland and Brazil in addition to Los Angeles, New York and St. Louis.

### WINNING STREAK

I was excited to showcase my true gaming skills when defending my title as CPL Champion of the year at the CPL Winter 2001 because I would be competing in a totally different first person shooter (fps) game, Alien vs. Predator II. I won that competition and walked away with a new car. The next year I won the same title playing Unreal Tournament 2003, becoming the only three-time CPL champion of the year. And I did it playing a different game each year, something no one else has ever done and a feat of which I am extremely proud.

At QuakeCon 2002, I faced off against my rival ZeRo4 in one of the most highly anticipated matches of the year, winning in a 14 to (-1) killer victory. Competing at Quakecon 2004, I became the World's 1st Doom3 Champion by defeating Daler in a series of very challenging matches and earning \$25,000 for the victory.

Since then Fatal1ty has traveled the globe to compete against the best in the world, winning prizes and acclaim, including the 2005 CPL World Tour Championship in New York City for a \$150,000 first place triumph. In August 2007, Johnathan was awarded the first ever Lifetime Achievement Award in the four year history of the eSports-Award for "showing exceptional sportsmanship, taking part in shaping eSports into what it is today and for being the prime representative of this young sport. He has become the figurehead for eSports worldwide".

---

## LIVIN' LARGE

Since my first big tournament wins, I have been a “Professional Cyberathlete”, traveling the world and livin' large with lots of International media coverage on outlets such as MTV, ESPN and a 60 Minutes segment on CBS to name only a few. It's unreal - it's crazy. I'm living a dream by playing video games for a living. I've always been athletic and took sports like hockey and football very seriously, working out and training hard. This discipline helps me become a better gamer and my drive to be the best has opened the doors necessary to become a professional.

## A DREAM

Now, another dream is being realized – building the ultimate gaming computer, made up of the best parts under my own brand. Quality hardware makes a huge difference in competitions...a couple more frames per second and everything gets really nice. It's all about getting the computer processing faster and allowing more fluid movement around the maps.

My vision for Fatal1ty hardware is to allow gamers to focus on the game without worrying about their equipment, something I've preached since I began competing. I don't want to worry about my equipment. I want to be there – over and done with - so I can focus on the game. I want it to be the fastest and most stable computer equipment on the face of the planet, so quality is what Fatal1ty Brand products represent.



Johnathan “Fatal1ty” Wendel



---

## Copyright Notice:

No part of this installation guide may be reproduced, transcribed, transmitted, or translated in any language, in any form or by any means, except duplication of documentation by the purchaser for backup purpose, without written consent of ASRock Inc.

Products and corporate names appearing in this guide may or may not be registered trademarks or copyrights of their respective companies, and are used only for identification or explanation and to the owners' benefit, without intent to infringe.

## Disclaimer:

Specifications and information contained in this guide are furnished for informational use only and subject to change without notice, and should not be constructed as a commitment by ASRock. ASRock assumes no responsibility for any errors or omissions that may appear in this guide.

With respect to the contents of this guide, ASRock does not provide warranty of any kind, either expressed or implied, including but not limited to the implied warranties or conditions of merchantability or fitness for a particular purpose. In no event shall ASRock, its directors, officers, employees, or agents be liable for any indirect, special, incidental, or consequential damages (including damages for loss of profits, loss of business, loss of data, interruption of business and the like), even if ASRock has been advised of the possibility of such damages arising from any defect or error in the guide or product.



This device complies with Part 15 of the FCC Rules. Operation is subject to the following two conditions:

- (1) this device may not cause harmful interference, and
- (2) this device must accept any interference received, including interference that may cause undesired operation.

## CALIFORNIA, USA ONLY

The Lithium battery adopted on this motherboard contains Perchlorate, a toxic substance controlled in Perchlorate Best Management Practices (BMP) regulations passed by the California Legislature. When you discard the Lithium battery in California, USA, please follow the related regulations in advance.

"Perchlorate Material-special handling may apply, see [www.dtsc.ca.gov/hazardouswaste/perchlorate](http://www.dtsc.ca.gov/hazardouswaste/perchlorate)"

**ASRock Website:** <http://www.asrock.com>

Published November 2011  
Copyright©2011 ASRock INC. All rights reserved.

# Motherboard Layout

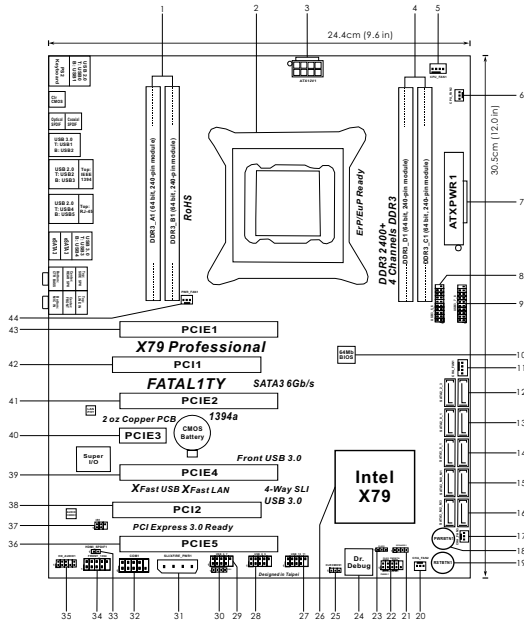

- |    |   |    |  |
|----|---|----|--|
| 1  | 2 x 240-pin DDR3 DIMM Slots (DDR3_A1, DDR3_B1, Black) | 24 | Dr. Debug  |
| 2  | 2011-Pin CPU Socket                                   | 25 | Clear CMOS Jumper (CLRCMOS1)                     |
| 3  | ATX 12V Power Connector (ATX12V1)                     | 26 | Intel X79 Chipset                                |
| 4  | 2 x 240-pin DDR3 DIMM Slots (DDR3_D1, DDR3_C1, Black) | 27 | USB 2.0 Header (USB_10_11, Black)                |
| 5  | CPU Fan Connector (CPU_FAN1)                          | 28 | USB 2.0 Header (USB_8_9, Black)                  |
| 6  | CPU Fan Connector (CPU_FAN2)                          | 29 | USB 2.0 Header (USB_6_7, Black)                  |
| 7  | ATX Power Connector (ATXPWR1)                         | 30 | Consumer Infrared Module Header (CIR1, Gray)     |
| 8  | USB 3.0 Header (USB3_5_6, Black)                      | 31 | SLI / XFire Power Connector                      |
| 9  | USB 3.0 Header (USB3_7_8, Black)                      | 32 | COM Port Header (COM1)                           |
| 10 | SPI Flash Memory (64Mb)                               | 33 | HDMI_SPDIF Header (HDMI_SPDIF1, Black)           |
| 11 | Chassis Fan Connector (CHA_FAN1)                      | 34 | Front Panel IEEE 1394 Header (FRONT_1394, Black) |
| 12 | SATA2 Connectors (SATA2_2_3, Black)                   | 35 | Front Panel Audio Header (HD_AUDIO1, Black)      |
| 13 | SATA2 Connectors (SATA2_0_1, Black)                   | 36 | PCI Express 3.0 x16 Slot (PCIE5, Red)            |
| 14 | SATA3 Connectors (SATA3_0_1, Red)                     | 37 | Infrared Module Header (IR1)                     |
| 15 | SATA3 Connectors (SATA3_M0_M1, Red)                   | 38 | PCI Slot (PCI2, Black)                           |
| 16 | SATA3 Connectors (SATA3_M2_M3, Red)                   | 39 | PCI Express 3.0 x16 Slot (PCIE4, Red)            |
| 17 | Chassis Fan Connector (CHA_FAN3)                      | 40 | PCI Express 2.0 x1 Slot (PCIE3, Black)           |
| 18 | Power Switch (PWRBTN)                                 | 41 | PCI Express 3.0 x16 Slot (PCIE2, Red)            |
| 19 | Reset Switch (RSTBTN)                                 | 42 | PCI Slot (PCI1, Black)                           |
| 20 | Chassis Fan Connector (CHA_FAN2)                      | 43 | PCI Express 3.0 x16 Slot (PCIE1, Red)            |
| 21 | Chassis Speaker Header (SPEAKER1, Black)              | 44 | Power Fan Connector (PWR_FAN1)                   |
| 22 | System Panel Header (PANEL1, Black)                   |    |  |
| 23 | Power LED Header (PLED1)                              |    |  |



## I/O Panel

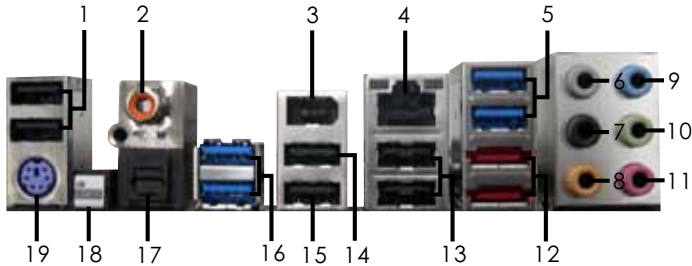

- |       |                            |        |                             |
|-------|----------------------------|--------|-----------------------------|
| 1     | USB 2.0 Ports (USB01)      | 11     | Microphone (Pink)           |
| 2     | Coaxial SPDIF Out Port     | *** 12 | eSATA3 Connectors           |
| 3     | IEEE 1394 Port (IEEE 1394) | 13     | USB 2.0 Ports (USB45)       |
| * 4   | LAN RJ-45 Port             | 14     | Fatal1ty Mouse Port (USB2)  |
| 5     | USB 3.0 Ports (USB3_34)    | 15     | USB 2.0 Port (USB3)         |
| 6     | Side Speaker (Gray)        | 16     | USB 3.0 Ports (USB3_12)     |
| 7     | Rear Speaker (Black)       | 17     | Optical SPDIF Out Port      |
| 8     | Central / Bass (Orange)    | 18     | Clear CMOS Switch (CLRCBTN) |
| 9     | Line In (Light Blue)       | 19     | PS/2 Keyboard Port (Purple) |
| ** 10 | Front Speaker (Lime)       |        |                             |

\* There are two LEDs next to the LAN port. Please refer to the table below for the LAN port LED indications.

### LAN Port LED Indications

Activity/Link LED		SPEED LED	
Status	Description	Status	Description
Off	No Link	Off	10Mbps connection
Blinking	Data Activity	Orange	100Mbps connection
On	Link	Green	1Gbps connection

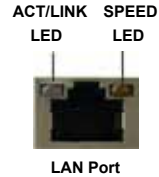

\*\* If you use 2-channel speaker, please connect the speaker's plug into "Front Speaker Jack".  
See the table below for connection details in accordance with the type of speaker you use.

**TABLE for Audio Output Connection**

Audio Output Channels	Front Speaker (No. 10)	Rear Speaker (No. 7)	Central / Bass (No. 8)	Side Speaker (No. 6)
2	V	--	--	--
4	V	V	--	--
6	V	V	V	--
8	V	V	V	V

---

To enable Multi-Streaming function, you need to connect a front panel audio cable to the front panel audio header. After restarting your computer, you will find "Mixer" tool on your system. Please select "Mixer ToolBox" , click "Enable playback multi-streaming", and click "ok". Choose "2CH", "4CH", "6CH", or "8CH" and then you are allowed to select "Realtek HDA Primary output" to use Rear Speaker, Central/Bass, and Front Speaker, or select "Realtek HDA Audio 2nd output" to use front panel audio.

\*\*\* eSATA3 connector supports SATA Gen3 in cable 1M.

---

# 1. Introduction

Thank you for purchasing **Fatal1ty X79 Professional Series** motherboard, a reliable motherboard produced under ASRock's consistently stringent quality control. It delivers excellent performance with robust design conforming to ASRock's commitment to quality and endurance.

This Quick Installation Guide contains introduction of the motherboard and step-by-step installation guide. More detailed information of the motherboard can be found in the user manual presented in the Support CD.



Because the motherboard specifications and the BIOS software might be updated, the content of this manual will be subject to change without notice. In case any modifications of this manual occur, the updated version will be available on ASRock website without further notice. You may find the latest VGA cards and CPU support lists on ASRock website as well.

ASRock website <http://www.asrock.com>

If you require technical support related to this motherboard, please visit our website for specific information about the model you are using.

[www.asrock.com/support/index.asp](http://www.asrock.com/support/index.asp)

## 1.1 Package Contents

**Fatal1ty X79 Professional Series** Motherboard

(ATX Form Factor: 12.0-in x 9.6-in, 30.5 cm x 22.4 cm)

**Fatal1ty X79 Professional Series** Quick Installation Guide

**Fatal1ty X79 Professional Series** Support CD

6 x Serial ATA (SATA) Data Cables (Optional)

2 x Serial ATA (SATA) HDD Power Cables (Optional)

1 x I/O Panel Shield

1 x Front USB 3.0 Panel

4 x HDD Screws

6 x Chassis Screws

1 x Rear USB 3.0 Bracket

2 x ASRock SLI\_Bridge Cards

1 x ASRock SLI\_Bridge\_3S Card

1 x ASRock 3-Way SLI Bridge Card



### **ASRock Reminds You...**

To get better performance in Windows® 7 / 7 64-bit / Vista™ / Vista™ 64-bit, it is recommended to set the BIOS option in Storage Configuration to AHCI mode. For the BIOS setup, please refer to the "User Manual" in our support CD for details.

## 1.2 Specifications

<b>Platform</b>	<ul style="list-style-type: none"> <li>- ATX Form Factor: 12.0-in x 9.6-in, 30.5 cm x 24.4 cm</li> <li>- Premium Gold Capacitor design (100% Japan-made high-quality Conductive Polymer Capacitors)</li> </ul>
<b>CPU</b>	<ul style="list-style-type: none"> <li>- Supports Intel® Core™ i7 processor family for the LGA 2011 Socket</li> <li>- Digital PWM Design</li> <li>- Advanced 16 + 2 Power Phase Design</li> <li>- Supports Intel® Turbo Boost 2.0 Technology</li> <li>- Supports Hyper-Threading Technology (see <b>CAUTION 1</b>)</li> <li>- Supports Untied Overclocking Technology</li> </ul>
<b>Chipset</b>	<ul style="list-style-type: none"> <li>- Intel® X79</li> </ul>
<b>Memory</b>	<ul style="list-style-type: none"> <li>- Quad Channel DDR3 Memory Technology (see <b>CAUTION 2</b>)</li> <li>- 4 x DDR3 DIMM slots</li> <li>- Supports DDR3 2400+(OC)/2133(OC)/1866(OC)/1600/1333/1066 non-ECC, un-buffered memory</li> <li>- Supports DDR3 ECC, un-buffered memory with Intel® Workstation 1S Xeon® processors E5 16xx/26xx/46xx series in socket LGA 2011</li> <li>- Max. capacity of system memory: 32GB (see <b>CAUTION 3</b>)</li> <li>- Supports Intel® Extreme Memory Profile (XMP)1.3/1.2</li> </ul>
<b>Expansion Slot</b>	<ul style="list-style-type: none"> <li>- 4 x PCI Express 3.0 x16 slots (PCIe1/PCIe2/PCIe4/PCIe5: x16/8/16/0 mode or x16/8/8/8 mode (see <b>CAUTION 4</b>))</li> <li>- 1 x PCI Express 2.0 x 1 slot</li> <li>- 2 x PCI slots</li> <li>- Supports AMD Quad CrossFireX™, 4-Way CrossFireX™, 3-Way CrossFireX™ and CrossFireX™</li> <li>- Supports NVIDIA® Quad SLI™, 4-Way SLI™, 3-Way SLI™ and SLI™</li> </ul>
<b>Audio</b>	<ul style="list-style-type: none"> <li>- 7.1 CH HD Audio with Content Protection (Realtek ALC898 Audio Codec)</li> <li>- Premium Blu-ray audio support</li> <li>- Supports THX TruStudio™</li> </ul>
<b>LAN</b>	<ul style="list-style-type: none"> <li>- PCIe x1 Gigabit LAN 10/100/1000 Mb/s</li> <li>- Broadcom BCM57781</li> <li>- Supports Wake-On-LAN</li> <li>- Supports Energy Efficient Ethernet 802.3az</li> <li>- Supports PXE</li> </ul>
<b>Rear Panel I/O</b>	<ul style="list-style-type: none"> <li>I/O Panel</li> <li>- 1 x PS/2 Keyboard Port</li> </ul>



	<ul style="list-style-type: none"> <li>- 1 x Coaxial SPDIF Out Port</li> <li>- 1 x Optical SPDIF Out Port</li> <li>- 5 x Ready-to-Use USB 2.0 Ports</li> <li>- 1 x Fatal1ty Mouse Port (USB 2.0)</li> <li>- 2 x eSATA3 Connectors</li> <li>- 4 x Ready-to-Use USB 3.0 Ports</li> <li>- 1 x RJ-45 LAN Port with LED (ACT/LINK LED and SPEED LED)</li> <li>- 1 x IEEE 1394 Port</li> <li>- 1 x Clear CMOS Switch with LED</li> <li>- HD Audio Jack: Side Speaker/Rear Speaker/Central/Bass/Line in/Front Speaker/Microphone (see <b>CAUTION 5</b>)</li> </ul>
<b>SATA3</b>	<ul style="list-style-type: none"> <li>- 2 x SATA3 6.0 Gb/s connectors by Intel® X79, support RAID (RAID 0, RAID 1, RAID 5, RAID 10 and Intel Rapid Storage3.0), NCQ, AHCI and "Hot Plug" functions</li> <li>- 4 x SATA3 6.0 Gb/s connector by Marvell SE9172, support RAID (RAID 0 and RAID 1), NCQ, AHCI and "Hot Plug" functions</li> </ul>
<b>USB3.0</b>	<ul style="list-style-type: none"> <li>- 4 x Rear USB 3.0 ports by TI®, support USB 1.0/2.0/3.0 up to 5Gb/s</li> <li>- 2 x Front USB 3.0 headers (support 4 USB 3.0 ports) by TI®, support USB 1.0/2.0/3.0 up to 5Gb/s</li> </ul>
<b>Connector</b>	<ul style="list-style-type: none"> <li>- 4 x SATA2 3.0 Gb/s connectors, support RAID (RAID 0, RAID 1, RAID 5, RAID 10 and Intel Rapid Storage3.0), NCQ, AHCI and Hot Plug functions</li> <li>- 6 x SATA3 6.0Gb/s connectors</li> <li>- 1 x IR header</li> <li>- 1 x CIR header</li> <li>- 1 x COM port header</li> <li>- 1 x HDMI_SPDIF header</li> <li>- 1 x IEEE 1394 header</li> <li>- 1 x Power LED header</li> <li>- CPU/Chassis/Power FAN connector</li> <li>- 24 pin ATX power connector</li> <li>- 8 pin 12V power connector</li> <li>- SLI/XFire power connector</li> <li>- Front panel audio connector</li> <li>- 3 x USB 2.0 headers (support 6 USB 2.0 ports)</li> <li>- 2 x USB 3.0 header (supports 4 USB 3.0 ports)</li> <li>- 1 x Dr. Debug with LED</li> </ul>
<b>Smart Switch</b>	<ul style="list-style-type: none"> <li>- 1 x Power Switch with LED</li> </ul>

	<ul style="list-style-type: none"> <li>- 1 x Reset Switch with LED</li> <li>- 1 x Clear CMOS Switch with LED</li> </ul>
<b>BIOS Feature</b>	<ul style="list-style-type: none"> <li>- 64Mb AMI UEFI Legal BIOS with GUI support</li> <li>- Supports "Plug and Play"</li> <li>- ACPI 1.1 Compliance Wake Up Events</li> <li>- Supports jumperfree</li> <li>- SMBIOS 2.3.1 Support</li> <li>- CPU, VCCSA, DRAM, VTT, CPU PLL, PCH1.1V, PCH1.5V Voltage Multi-adjustment</li> </ul>
<b>Support CD</b>	<ul style="list-style-type: none"> <li>- Drivers, Utilities, AntiVirus Software (Trial Version), CyberLink MediaEspresso 6.5 Trial, ASRock Software Suite (ASRock MAGIX Multimedia Suite - OEM)</li> </ul>
<b>Unique Feature</b>	<ul style="list-style-type: none"> <li>- F-Stream (see <b>CAUTION 6</b>)</li> <li>- ASRock Instant Boot</li> <li>- ASRock Instant Flash (see <b>CAUTION 7</b>)</li> <li>- ASRock APP Charger (see <b>CAUTION 8</b>)</li> <li>- ASRock SmartView (see <b>CAUTION 9</b>)</li> <li>- ASRock XFast USB (see <b>CAUTION 10</b>)</li> <li>- ASRock XFast LAN (see <b>CAUTION 11</b>)</li> <li>- ASRock XFast Charger (see <b>CAUTION 12</b>)</li> <li>- ASRock XFast RAM (see <b>CAUTION 13</b>)</li> <li>- ASRock Crashless BIOS (see <b>CAUTION 14</b>)</li> <li>- Hybrid Booster: <ul style="list-style-type: none"> <li>- CPU Frequency Stepless Control (see <b>CAUTION 15</b>)</li> <li>- ASRock U-COP (see <b>CAUTION 16</b>)</li> <li>- Boot Failure Guard (B.F.G.)</li> </ul> </li> <li>- Good Night LED</li> </ul>
<b>Hardware Monitor</b>	<ul style="list-style-type: none"> <li>- CPU Temperature Sensing</li> <li>- Chassis Temperature Sensing</li> <li>- CPU/Chassis/Power Fan Tachometer</li> <li>- CPU/Chassis Quiet Fan (Allows Chassis Fan Speed Auto-Adjust by CPU Temperature)</li> <li>- CPU/Chassis Fan Multi-Speed Control</li> <li>- Voltage Monitoring: +12V, +5V, +3.3V, CPU Vcore</li> </ul>
<b>OS</b>	<ul style="list-style-type: none"> <li>- Microsoft® Windows® 7 / 7 64-bit / Vista™ / Vista™ 64-bit / XP / XP 64-bit compliant (see <b>CAUTION 17</b>)</li> </ul>
<b>Certifications</b>	<ul style="list-style-type: none"> <li>- FCC, CE, WHQL</li> <li>- ErP/EuP Ready (ErP/EuP ready power supply is required) (see <b>CAUTION 18</b>)</li> </ul>

\* For detailed product information, please visit our website: <http://www.asrock.com>

## WARNING

Please realize that there is a certain risk involved with overclocking, including adjusting the setting in the BIOS, applying Untied Overclocking Technology, or using third-party overclocking tools. Overclocking may affect your system's stability, or even cause damage to the components and devices of your system. It should be done at your own risk and expense. We are not responsible for possible damage caused by overclocking.

## CAUTION!

1. About the setting of "Hyper Threading Technology", please check page 67 of the User Manual in the support CD.
2. This motherboard supports Quad Channel Memory Technology. Before you implement Quad Channel Memory Technology, make sure to read the installation guide of memory modules on page 18 for proper installation.
3. Due to the operating system limitation, the actual memory size may be less than 4GB for the reservation for system usage under Windows® 7 / Vista™ / XP. For Windows® OS with 64-bit CPU, there is no such limitation. You can use ASRock XFast RAM to utilize the memory that Windows® cannot use.
4. Currently Intel® Socket 2011 Sandy Bridge-E Processor doesn't support PCIe 3.0, but this motherboard is already PCIe 3.0 hardware ready. It depends on Intel's CPU to enable PCIe 3.0. Please check Intel's website for information on future CPU updates and releases.
5. For microphone input, this motherboard supports both stereo and mono modes. For audio output, this motherboard supports 2-channel, 4-channel, 6-channel, and 8-channel modes. Please check the table on page 3 for proper connection.
6. F-Stream is an all-in-one tool to fine-tune different system functions in a user-friendly interface, which currently includes Hardware Monitor, Fan Control, Overclocking, OC DNA, Mouse Polling and IES. In the Hardware Monitor mode, F-Stream shows the major readings of your system. In Fan Control mode, F-Stream shows the fan speed and temperature for you to adjust. In Overclocking Control mode, F-Stream allows you to overclock the CPU frequency for optimal system performance. In OC DNA mode, you can save your OC settings as a profile and share them with your friends. Your friends can then load the OC profile in to their own system to get the same OC settings. In Mouse Polling mode, F-Stream allows you to adjust the mouse polling rate of the Fatal1ty Mouse port to add a professional level mouse configuration. In IES (Intelligent Energy Saver) mode, the voltage regulator can reduce the number of output phases to improve efficiency when the CPU cores are idle without sacrificing computing performance.
7. ASRock Instant Flash is a BIOS flash utility embedded in Flash ROM. This convenient BIOS update tool allows you to update system BIOS

---

without entering operating systems first like MS-DOS or Windows®. With this utility, you can press the <F6> key during the POST or the <F2> key to enter into the BIOS setup menu to access ASRock Instant Flash. Just launch this tool and save the new BIOS file to your USB flash drive, floppy disk or hard drive, then you can update your BIOS only in a few clicks without preparing an additional floppy diskette or other complicated flash utility. Please be noted that the USB flash drive or hard drive must use FAT32/16/12 file system.

8. If you desire a faster, less restricted way of charging your Apple devices, such as iPhone/iPad/iPod Touch, ASRock has prepared a wonderful solution for you - ASRock APP Charger. Simply install the APP Charger driver, it makes your iPhone charge much quickly from your computer and up to 40% faster than before. ASRock APP Charger allows you to quickly charge many Apple devices simultaneously and even supports continuous charging when your PC enters into Standby mode (S1), Suspend to RAM (S3), hibernation mode (S4) or power off (S5). With APP Charger driver installed, you can easily enjoy the marvelous charging experience. ASRock website: <http://www.asrock.com/Feature/AppCharger/index.asp>
9. ASRock SmartView, a new function for internet browsers, is the smart start page for IE that combines your most visited web sites, your history, your Facebook friends and your real-time newsfeed into an enhanced view for a more personal Internet experience. ASRock motherboards are exclusively equipped with the ASRock SmartView utility that helps you keep in touch with friends on-the-go. To use ASRock SmartView feature, please make sure your OS version is Windows® 7 / 7 64 bit / Vista™ / Vista™ 64 bit, and your browser version is IE8. ASRock website: <http://www.asrock.com/Feature/SmartView/index.asp>
10. ASRock XFast USB can boost USB storage device performance. The performance may depend on the properties of the device.
11. ASRock XFast LAN provides a faster internet access, which includes the benefits listed below. LAN Application Prioritization: You can configure your application's priority ideally and/or add new programs. Lower Latency in Game: After setting online game's priority higher, it can lower the latency in games. Traffic Shaping: You can watch Youtube HD videos and download simultaneously. Real-Time Analysis of Your Data: With the status window, you can easily recognize which data streams you are transferring currently.
12. ASRock XFast Charger is the best and fastest technology to charge your mobile devices via PC. With the superb XFast Charger USB port, users are assured to enjoy the quick charging experience anytime. In addition to Apple devices, it is also capable of Charging the BC 1.1 standard smart devices. Please refer to page 33 for details.
13. ASRock XFast RAM is a new function that is included into F-Stream. It fully utilizes the memory space that cannot be used under Windows® OS 32-bit CPU. ASRock XFast RAM shortens the loading time of previously visited websites, making web surfing faster than ever. And it also boosts

---

the speed of Adobe Photoshop 5 times faster. Another advantage of ASRock XFast RAM is that it reduces the frequency of accessing your SSDs or HDDs in order to extend their lifespan.

14. ASRock Crashless BIOS allows users to update their BIOS without fear of failing. If power loss occurs during the BIOS update process, ASRock Crashless BIOS will automatically finish the BIOS update procedure after regaining power. Please note that BIOS files need to be placed in the root directory of your USB disk. Only USB2.0 ports support this feature.
15. Although this motherboard offers stepless control, it is not recommended to perform over-clocking. Frequencies other than the recommended CPU bus frequencies may cause instability of the system or damage the CPU.
16. While CPU overheat is detected, the system will automatically shutdown. Before you resume the system, please check if the CPU fan on the motherboard functions properly and unplug the power cord, then plug it back again. To improve heat dissipation, remember to spray thermal grease between the CPU and the heatsink when you install the PC system.
17. Intel Rapid Storage Technology enterprise 3.0 and ASRock XFast RAM are not supported by Microsoft® Windows® XP / XP 64-bit.
18. EuP stands for Energy Using Product, was a provision regulated by the European Union to define the power consumption for the completed system. According to EuP, the total AC power of the completed system should be under 1.00W in off mode condition. To meet EuP standards, an EuP ready motherboard and an EuP ready power supply are required. According to Intel's suggestion, the EuP ready power supply must meet the standard of 5v, and the standby power efficiency should be higher than 50% under 100 mA current consumption. For EuP ready power supply selection, we recommend you to check with the power supply manufacturer for more details.

---

## 2. Installation

### Pre-installation Precautions

Take note of the following precautions before you install motherboard components or change any motherboard settings.

1. Unplug the power cord from the wall socket before touching any component. Failure to do so may cause severe damage to the motherboard, peripherals, and/or components.
2. To avoid damaging the motherboard components due to static electricity, NEVER place your motherboard directly on the carpet or the like. Also remember to use a grounded wrist strap or touch a safety grounded object before you handle components.
3. Hold components by the edges and do not touch the ICs.
4. Whenever you uninstall any component, place it on a grounded antistatic pad or in the bag that comes with the component.
5. When placing screws into the screw holes to secure the motherboard to the chassis, please do not over-tighten the screws! Doing so may damage the motherboard.

### 2.1 CPU Installation

For the installation of Intel 2011-Pin CPU, please follow the steps below.

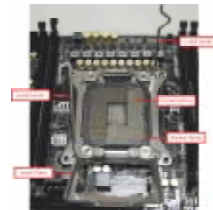

2011-Pin Socket Overview



Before you insert the 2011-Pin CPU into the socket, please check if the CPU surface is unclean or if there are any bent pins in the socket. Do not force to insert the CPU into the socket if above situation is found. Otherwise, the CPU will be seriously damaged.

Step 1. Open the socket:

Step 1-1. Disengage the left lever by pressing it down and sliding it out of the hook.



Step 1-2. Disengage the right lever by pressing it down and sliding it out of the hook.

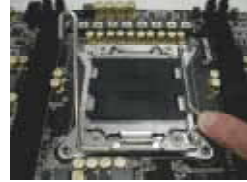

Step 1-3. Keep the right lever positioned at about 90 degrees in order to flip up the load plate.



Step 2. Insert the 2011-Pin CPU:

Step 2-1. Hold the CPU by the edge with the triangle mark (Pin 1) on your upper right corner.



Step 2-2. Locate Pin1 and the two orientation key notches.

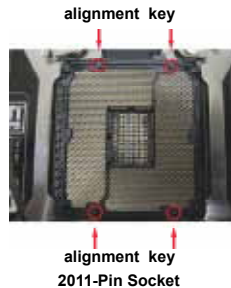
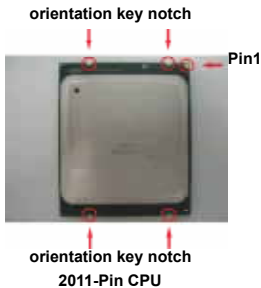



For proper inserting, please ensure to match the four orientation key notches of the CPU with the four alignment keys of the socket.

Step 2-3. Carefully place the CPU into the socket by using a purely vertical motion.

Step 2-4. Verify that the CPU is within the socket and properly mated to the orient keys.



Step 3. Close the socket:

Step 3-1. Flip the load plate onto the IHS, then the cover will automatically come off by itself.



The cover must be placed if returning the motherboard for after service.

Step 3-2. Press down the right load lever, and secure it with the load plate tab under the retention tab.



Step 3-3. Press down the left load lever, and secure it with the load plate tab under the retention tab.





---

## 2.2 Installation of CPU Fan and Heatsink

This motherboard is equipped with 2011-Pin socket that supports Intel 2011-Pin CPU. Please adopt the type of heatsink and cooling fan compliant with Intel 2011-Pin CPU to dissipate heat. Before you installed the heatsink, you need to spray thermal interface material between the CPU and the heatsink to improve heat dissipation. Ensure that the CPU and the heatsink are securely fastened and in good contact with each other. Then connect the CPU fan to the CPU\_FAN connector (CPU\_FAN1, see page 4, No. 5).

**For proper installation, please kindly refer to the instruction manuals of your CPU fan and heatsink.**

Below is an example to illustrate the installation of the heatsink for 2011-Pin CPU.

Step 1. Apply thermal interface material onto center of IHS on the socket surface.



Step 2. Place the heatsink onto the socket. Ensure fan cables are oriented on side closest to the CPU fan connector on the motherboard (CPU\_FAN1, see page 4, No. 5).

Step 3. Align screws with the motherboard's holes.

Step 4. Use a screw driver to install the screws.

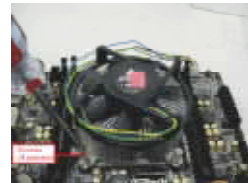

If you don't fasten the screws, the heatsink cannot be secured on the motherboard.

Step 5. Connect fan header with the CPU fan connector on the motherboard.

Step 6. Secure excess cable with tie-wrap to ensure the cable does not interfere with fan operation or contact other components.

## 2.3 Installation of Memory Modules (DIMM)

This motherboard provides four 240-pin DDR3 (Double Data Rate 3) DIMM slots, and supports Quad Channel Memory Technology. For quad channel configuration, you always need to install **identical** (the same brand, speed, size and chip-type) DDR3 DIMM in the slots: You have to install **identical** DDR3 DIMM in DDR3\_A1, DDR3\_B1, DDR3\_D1 and DDR3\_C1 (Black slots; see p.4 No.1 and No. 4), so that Quad Channel Memory Technology can be activated.



1. If only two memory modules are installed in the DDR3 DIMM slots, then Dual Channel Memory Technology is activated. If three memory modules are installed, then Triple Channel Memory Technology is activated. If four memory modules are installed in the DDR3 DIMM slots, then Quad Channel Memory Technology is activated.
2. It is not allowed to install a DDR or DDR2 memory module into DDR3 slot; otherwise, this motherboard and DIMM may be damaged.

### Installing a DIMM



Please make sure to disconnect power supply before adding or removing DIMMs or the system components.

- Step 1. Unlock a DIMM slot by pressing the retaining clips outward.
- Step 2. Align a DIMM on the slot such that the notch on the DIMM matches the break on the slot.

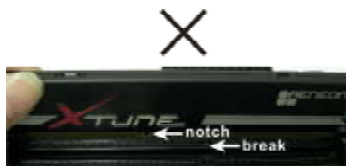
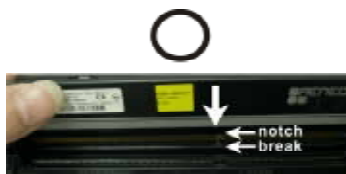

The DIMM only fits in one correct orientation. It will cause permanent damage to the motherboard and the DIMM if you force the DIMM into the slot at incorrect orientation.

- Step 3. Firmly insert the DIMM into the slot until the retaining clips at both ends fully snap back in place and the DIMM is properly seated.

## 2.4 Expansion Slots (PCI and PCI Express Slots)

There are 2 PCI slots and 5 PCI Express slots on this motherboard.

**PCI slot:** PCI slot is used to install expansion cards that have the 32-bit PCI interface.

**PCIe slots:**PCIE1 / PCIE2 / PCIE4 / PCIE5 (PCIE 3.0 x16 slots) are used for PCI Express graphics cards.

PCIE3 (PCIE2.0 x1 slot) is used for PCI Express cards with x1 lane width. Such as ASRock Game Blaster, Gigabit LAN card or SATA2 cards, etc.

**PCIe Slot Configurations**

	PCIE1	PCIE2	PCIE4	PCIE5
<b>Two Graphics Cards in CrossFireX™ or SLI™ Mode</b>	x16	N/A	x16	N/A
<b>Three Graphics Cards in 3-Way CrossFireX™ or 3-Way SLI™ Mode</b>	x16	x8	x16	N/A
<b>Four Graphics Cards in 4-Way CrossFireX™ or 4-Way SLI™ Mode</b>	x16	x8	x8	x8



1. In single VGA card mode, it is recommended to install a PCI Express x16 graphics card in the PCIE1 slot.
2. In CrossFireX™ mode or SLI™ mode, please install the PCI Express x16 graphics cards in PCIE1 and PCIE4 slots. Therefore, both these two slots will work at x16 bandwidth.
3. In 3-Way CrossFireX™ or 3-Way SLI™ mode, please install the PCI Express x16 graphics cards in PCIE1, PCIE2 and PCIE4 slots. Therefore, both PCIE1 and PCIE4 will work at x16 bandwidth, while PCIE2 works at x8 bandwidth.
4. In 4-Way CrossFireX™ or 4-Way SLI™ mode, please install the PCI Express x16 graphics cards in PCIE1, PCIE2, PCIE4 and PCIE5 slots. Therefore, PCIE1 will work at x16 bandwidth, while PCIE2, PCIE4 and PCIE5 works at x8 bandwidth.
5. Please connect a chassis fan to the motherboard's chassis fan connector (CHA\_FAN1, CHA\_FAN2 or CHA\_FAN3) when using multiple graphics cards for better thermal environment.
6. Currently Intel® Socket 2011 Sandy Bridge-E Processor doesn't support PCIE 3.0, but this motherboard is already PCIE 3.0 hardware ready. It depends on Intel's CPU to enable PCIE 3.0. Please check Intel's website for information on future CPU updates and releases.

---

## Installing an expansion card

- Step 1. Before installing an expansion card, please make sure that the power supply is switched off or the power cord is unplugged. Please read the documentation of the expansion card and make necessary hardware settings for the card before you start the installation.
- Step 2. Remove the system unit cover (if your motherboard is already installed in a chassis).
- Step 3. Remove the bracket facing the slot that you intend to use. Keep the screws for later use.
- Step 4. Align the card connector with the slot and press firmly until the card is completely seated on the slot.
- Step 5. Fasten the card to the chassis with screws.
- Step 6. Replace the system cover.

---

## 2.5 SLI™, 3-Way SLI™, 4-Way SLI™ and Quad SLI™ Operation Guide

This motherboard supports NVIDIA® SLI™, 3-Way SLI™, 4-Way SLI™ and Quad SLI™ (Scalable Link Interface) technology that allows you to install up to four identical PCI Express x16 graphics cards. Currently, NVIDIA® SLI™ technology supports Windows® XP / XP 64-bit / Vista™ / Vista™ 64-bit / 7 / 7 64-bit OS. NVIDIA® 3-Way SLI™, 4-Way SLI™ and Quad SLI™ technology supports Windows® Vista™ / Vista™ 64-bit / 7 / 7 64-bit OS only. Please follow the installation procedures in this section.



### Requirements

1. For SLI™ technology, you should have two identical SLI™-ready graphics cards that are NVIDIA® certified. For 3-Way SLI™ technology you should have three, whereas for 4-Way SLI™ technology you should have four. For Quad SLI™ technology, you should have two identical Quad SLI™-ready graphics cards that are NVIDIA® certified.
2. Make sure that your graphics card driver supports NVIDIA® SLI™ technology (driver version 280.41 and later). Download the driver from NVIDIA website ([www.nvidia.com](http://www.nvidia.com)).
3. Make sure that your power supply unit (PSU) can provide at least the minimum power required by your system. It is recommended to use NVIDIA® certified PSU. Please refer to NVIDIA® website for details.

### 2.5.1 Graphics Card Setup

#### 2.5.1.1 Installing Two SLI™-Ready Graphics Cards

- Step 1. Install the identical SLI™-ready graphics cards that are NVIDIA® certified because different types of graphics cards will not work together properly. (Even the GPU chips version shall be the same.) Insert one graphics card into PCIE1 slot and the other graphics card to PCIE4 slot. Make sure that the cards are properly seated on the slots.



---

Step2. If required, connect the auxiliary power source to the PCI Express graphics cards.



Step3. Align and insert the ASRock SLI\_Bridge\_3S Card to the goldfingers on each graphics card. Make sure the ASRock SLI\_Bridge\_3S Card is firmly in place.



**ASRock SLI\_Bridge\_3S Card**



Step4. Connect a VGA cable or a DVI cable to the monitor connector or the DVI connector of the graphics card that is inserted to PCIE1 slot.

---

### 2.5.1.2 Installing Three SLI™-Ready Graphics Cards

Step 1. Install the identical 3-Way SLI™-ready graphics cards that are NVIDIA® certified because different types of graphics cards will not work together properly. (Even the GPU chips version shall be the same.) Each graphics card should have two goldfingers for the 3-Way SLI Bridge connector. Insert one graphics card into PCIE1 slot, another graphics card to PCIE2 slot, and the other graphics card to PCIE4 slot. Make sure that the cards are properly seated on the slots.



**Two Goldfingers**



Step2. Connect the auxiliary power source to the PCI Express graphics card. Please make sure that both power connectors on the PCI Express graphics card are connected. Repeat this step on the three graphics cards.



Step3. Align and insert ASRock 3-Way SLI Bridge Card to the goldfingers on each graphics card. Make sure ASRock 3-Way SLI Bridge Card is firmly in place.



**ASRock 3-Way SLI Bridge Card**



Step4. Connect a VGA cable or a DVI cable to the monitor connector or the DVI connector of the graphics card that is inserted to PCIE1 slot.

### 2.5.1.3 Installing Four SLI™-Ready Graphics Cards

Step 1. Install the identical 4-Way SLI™-ready graphics cards that are NVIDIA® certified because different types of graphics cards will not work together properly. (Even the GPU chips version shall be the same.) Each graphics card should have two goldfingers for the ASRock SLI Bridge Card connectors. Insert one graphics card into the PCIE1 slot, another graphics card into the PCIE2 slot, the third graphics card into the PCIE4 slot and the last graphics card into the PCIE5 slot. Make sure that the cards are properly seated on the slots.



**Two Goldfingers**



Step 2. Connect the auxiliary power source to the PCI Express graphics card. Please make sure that both power connectors on the PCI Express graphics card are connected. Repeat this step on the other graphics cards.



Step 3. Align and insert an ASRock SLI Bridge Card to the goldfingers of the first and second graphics card. Install the second ASRock SLI Bridge Card to the goldfingers of the third and fourth graphics card. Connect the second and the fourth graphics card with the ASRock SLI\_Bridge\_3S Card. Make sure the ASRock SLI Bridge Cards are firmly in place.



**2 ASRock SLI\_Bridge Cards  
and an ASRock SLI\_Bridge\_3S Card**

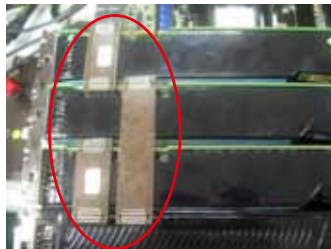

Step 4. Connect a VGA cable or a DVI cable to the monitor connector or the DVI connector of the graphics card that is inserted to PCIE1 slot.



---

## 2.5.2 Driver Installation and Setup

Install the graphics card drivers to your system. After that, you can enable the Multi-Graphics Processing Unit (GPU) feature in the NVIDIA® nView system tray utility. Please follow the below procedures to enable the multi-GPU feature.

**For Windows® XP / XP 64-bit OS:  
(For SLI™ mode only)**

A. Double-click **NVIDIA Settings icon** on your Windows® taskbar.



B. From the pop-up menu, select **Set SLI and PhysX configuration**. In **Set PhysX GPU acceleration** item, please select **Enabled**. In **Select an SLI configuration** item, please select **Enable SLI**. And click **Apply**.

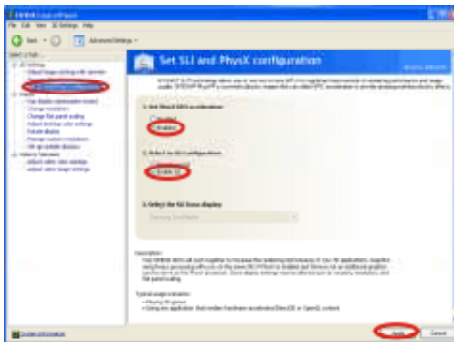

C. Reboot your system.

D. You can freely enjoy the benefits of SLI™.

**For Windows® Vista™ / Vista™ 64-bit / 7 / 7 64-bit OS:  
(For SLI™ and Quad SLI™ mode)**

- A. Click the **Start** icon on your Windows taskbar.
- B. From the pop-up menu, select **All Programs**, and then click **NVIDIA Corporation**.
- C. Select **NVIDIA Control Panel** tab.
- D. Select **Control Panel** tab.

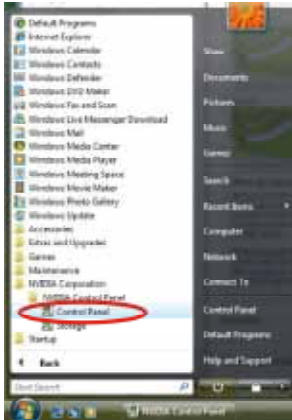

- E. From the pop-up menu, select **Set SLI and PhysX configuration**. In **Set PhysX GPU acceleration** item, please select **Enabled**.
- F. In **Select an SLI configuration** item, please select **Enable SLI**. And click **Apply**.

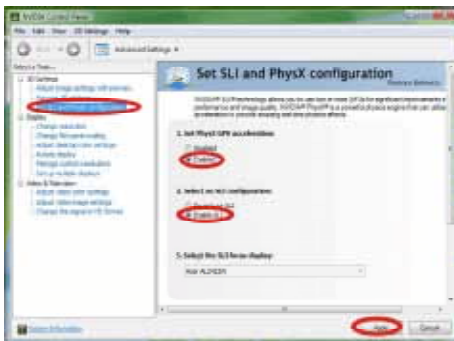

- G. Reboot your system.
- H. You can freely enjoy the benefits of SLI™ or Quad SLI™.

---

**For Windows® Vista™ / Vista™ 64-bit / 7 / 7 64-bit OS:  
(For 3-Way SLI™ or 4-Way SLI™ mode)**

- A. Follow steps A to E on page 26.
- B. In **Select an SLI configuration** item, please select **Enable 3-way SLI** or **Enable 4-way SLI** and click **Apply**.

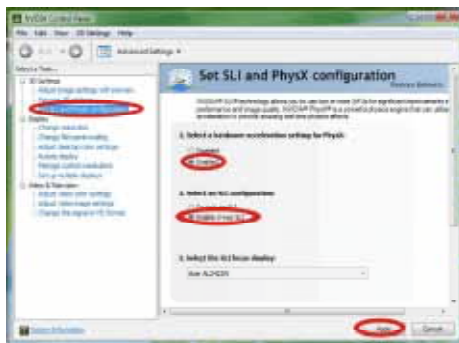

- C. Reboot your system.
- D. You can freely enjoy the benefits of 3-Way SLI™ or 4-Way SLI™.

\* SLI™ appearing here is a registered trademark of NVIDIA® Technologies Inc., and is used only for identification or explanation and to the owners' benefit, without intent to infringe.

---

## 2.6 CrossFireX™, 3-Way CrossFireX™, 4-Way CrossFireX™ and Quad CrossFireX™ Operation Guide

This motherboard supports CrossFireX™, 3-way CrossFireX™, 4-way CrossFireX™ and Quad CrossFireX™. CrossFireX™ technology offers the most advantageous means available of combining multiple high performance Graphics Processing Units (GPU) in a single PC. Combining a range of different operating modes with intelligent software design and an innovative interconnect mechanism, CrossFireX™ enables the highest possible level of performance and image quality in any 3D application. Currently CrossFireX™ is supported with Windows® XP with Service Pack 2 / Vista™ / 7 OS. 3-way CrossFireX™, 4-way CrossFireX™ and Quad CrossFireX™ are supported with Windows® Vista™ / 7 OS only. Please check AMD's website for ATI™ CrossFireX™ driver updates.



1. If a customer incorrectly configures their system they will not see the performance benefits of CrossFireX™. All three CrossFireX™ components, a CrossFireX™ Ready graphics card, a CrossFireX™ Ready motherboard and a CrossFireX™ Edition co-processor graphics card, must be installed correctly to benefit from the CrossFireX™ multi-GPU platform.
2. If you pair a 12-pipe CrossFireX™ Edition card with a 16-pipe card, both cards will operate as 12-pipe cards while in CrossFireX™ mode.

### 2.6.1 Graphics Card Setup

#### 2.6.1.1 Installing Two CrossFireX™-Ready Graphics Cards



Different CrossFireX™ cards may require different methods to enable CrossFireX™ feature. In below procedures, we use Radeon HD 5770 as the example graphics card. For other CrossFireX™ cards that AMD has released or will release in the future, please refer to AMD graphics card manuals for detailed installation guide.

- Step 1. Insert one Radeon graphics card into PCIE1 slot and the other Radeon graphics card to PCIE4 slot. Make sure that the cards are properly seated on the slots.



---

Step 2. Connect two Radeon graphics cards by installing CrossFire Bridge on CrossFire Bridge Interconnects on the top of Radeon graphics cards. (CrossFire Bridge is provided with the graphics card you purchase, not bundled with this motherboard. Please refer to your graphics card vendor for details.)



**CrossFire Bridge**



Step 3. Connect the DVI monitor cable to the DVI connector on the Radeon graphics card on PCIE1 slot. (You may use the DVI to D-Sub adapter to convert the DVI connector to D-Sub interface, and then connect the D-Sub monitor cable to the DVI to D-Sub adapter.)



---

## 2.6.1.2 Installing Three CrossFire™-Ready Graphics Cards

Step 1. Install the identical 3-Way CrossFire™-ready graphics cards that are AMD® certified because different types of graphics cards will not work together properly. (Even the GPU chips version shall be the same.) Insert one graphics card into PCIE1 slot, another graphics card to PCIE2 slot, and the other graphics card to PCIE4 slot. Make sure that the cards are properly seated on the slots.



Step 2. Use one CrossFire™ Bridge to connect Radeon graphics cards on PCIE1 and PCIE2 slots, and use the other CrossFire™ Bridge to connect Radeon graphics cards on PCIE2 and PCIE4 slots. (CrossFire™ Bridge is provided with the graphics card you purchase, not bundled with this motherboard. Please refer to your graphics card vendor for details.)



CrossFire™ Bridge



Step 3. Connect the DVI monitor cable to the DVI connector on the Radeon graphics card on PCIE1 slot. (You may use the DVI to D-Sub adapter to convert the DVI connector to D-Sub interface, and then connect the D-Sub monitor cable to the DVI to D-Sub adapter.)



---

### 2.6.1.3 Installing Four CrossFire™-Ready Graphics Cards

Step 1. Install the identical 4-Way CrossFire™-ready graphics cards that are AMD® certified because different types of graphics cards will not work together properly. (Even the GPU chips version shall be the same.) Insert one graphics card into PCIE1 slot, another graphics card into PCIE2 slot, the third graphics card into PCIE4 slot and the last graphics card into PCIE5 slot. Make sure that the cards are properly seated on the slots.



Step 2. Use one CrossFire™ Bridge to connect Radeon graphics cards on PCIE1 and PCIE2 slots, another CrossFire™ Bridge to connect Radeon graphics cards on PCIE2 and PCIE4 slots, and use the third CrossFire™ Bridge to connect Radeon graphics cards on PCIE4 and PCIE5 slots. (CrossFire™ Bridge is provided with the graphics card you purchase, not bundled with this motherboard. Please refer to your graphics card vendor for details.)



CrossFire™ Bridge



Step 3. Connect the DVI monitor cable to the DVI connector on the Radeon graphics card on PCIE1 slot. (You may use the DVI to D-Sub adapter to convert the DVI connector to D-Sub interface, and then connect the D-Sub monitor cable to the DVI to D-Sub adapter.)



---

## 2.6.2 Driver Installation and Setup

- Step 1. Power on your computer and boot into OS.
- Step 2. Remove the AMD driver if you have any VGA driver installed in your system.



The Catalyst Uninstaller is an optional download. We recommend using this utility to uninstall any previously installed Catalyst drivers prior to installation. Please check AMD's website for ATI™ driver updates.

- Step 3. Install the required drivers to your system.

**For Windows® XP OS:**

A. AMD recommends Windows® XP Service Pack 2 or higher to be installed (If you have Windows® XP Service Pack 2 or higher installed in your system, there is no need to download it again):

<http://www.microsoft.com/windowsxp/sp2/default.msp>

B. You must have Microsoft .NET Framework installed prior to downloading and installing the CATALYST Control Center. Please check Microsoft website for details.

**For Windows® 7 / Vista™ OS:**

Install the CATALYST Control Center. Please check AMD's website for details.

- Step 4. Restart your computer.

- Step 5. Install the VGA card driver to your system, and restart your computer. Then you will find "ATI Catalyst Control Center" on your Windows® taskbar.



ATI Catalyst Control Center

- Step 6. Double-click "ATI Catalyst Control Center". Click "View", select "CrossFireX™", and then check the item "Enable CrossFireX™". Select "2 GPUs" and click "Apply" (if you install two Radeon graphics cards). Select "3 GPUs" and click "OK" (if you install three Radeon graphics cards). Select "4 GPUs" and click "OK" (if you install four Radeon graphics cards).





Although you have selected the option “Enable CrossFire™”, the CrossFireX™ function may not work actually. Your computer will automatically reboot. After restarting your computer, please confirm whether the option “Enable CrossFire™” in “ATI Catalyst Control Center” is selected or not; if not, please select it again, and then you are able to enjoy the benefits of CrossFireX™.

Step 7. You can freely enjoy the benefits of CrossFireX™, 3-Way CrossFireX™, 4-Way CrossFireX™ or Quad CrossFireX™.

- \* CrossFireX™ appearing here is a registered trademark of AMD Technologies Inc., and is used only for identification or explanation and to the owners' benefit, without intent to infringe.
- \* For further information of AMD CrossFireX™ technology, please check AMD's website for updates and details.

## 2.7 Surround Display Feature

This motherboard supports Surround Display upgrade. With the external add-on PCI Express VGA cards, you can easily enjoy the benefits of Surround Display feature. For detailed instructions, please refer to the document at the following path in the Support CD:

..\ Surround Display Information

## 2.8 ASRock Smart Remote Installation Guide

ASRock Smart Remote is only used for ASRock motherboard with CIR header. Please refer to below procedures for the quick installation and usage of ASRock Smart Remote.

Step1. Find the CIR header located next to the USB 2.0 header on ASRock motherboard.



Step2. Connect the front USB cable to the USB 2.0 header (as below, pin 1-5) and the CIR header. Please make sure the wire assignments and the pin assignments are matched correctly.

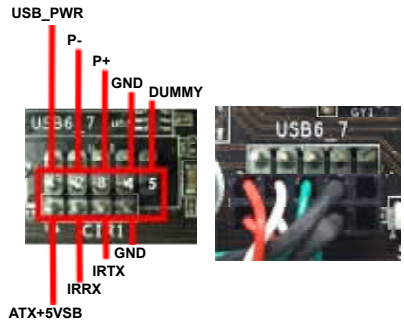

Step3. Install Multi-Angle CIR Receiver to the front USB port. If Multi-Angle CIR Receiver cannot successfully receive the infrared signals from MCE Remote Controller, please try to install it to the other front USB port.



3 CIR sensors in different angles



1. Only one of the front USB port can support CIR function. When the CIR function is enabled, the other port will remain USB function.
2. Multi-Angle CIR Receiver is used for front USB only. Please do not use the rear USB bracket to connect it on the rear panel. Multi-Angle CIR Receiver can receive the multi-direction infrared signals (top, down and front), which is compatible with most of the chassis on the market.
3. The Multi-Angle CIR Receiver does not support Hot-Plug function. Please install it before you boot the system.

\* ASRock Smart Remote is only supported by some of ASRock motherboards. Please refer to ASRock website for the motherboard support list: <http://www.asrock.com>

---

## 2.9 ASRock XFast Charger Operation Guide

ASRock XFast Charger is the best and fastest technology to charge your mobile devices via PC. With the superb XFast Charger USB port, users are assured to enjoy the quick charging experience anytime. In addition to Apple devices, it is also capable of Charging the BC 1.1 standard smart devices. Please refer to below instruction for proper operation.



This motherboard provides three USB ports for ASRock XFast Charger:

### 1. USB 2.0 port (USB0) on the I/O panel



### 2. USB 2.0 port (USB\_6) header

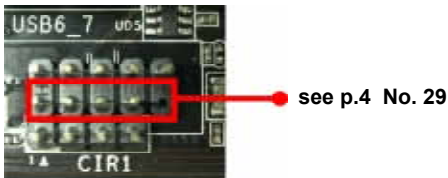

### 3. USB 3.0 port (USB3\_5) header

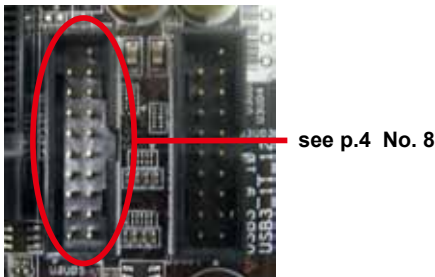



With ASRock XFast Charger feature, you can freely enjoy the quick charging convenience by installing the USB cable on these three ports.

## 2.10 Jumpers Setup

The illustration shows how jumpers are setup. When the jumper cap is placed on pins, the jumper is “Short”. If no jumper cap is placed on pins, the jumper is “Open”. The illustration shows a 3-pin jumper whose pin1 and pin2 are “Short” when jumper cap is placed on these 2 pins.



Jumper	Setting	Description
Clear CMOS Jumper (CLR CMOS1) (see p.4, No. 25)	 1_2 Default	 2_3 Clear CMOS

Note: CLR CMOS1 allows you to clear the data in CMOS. To clear and reset the system parameters to default setup, please turn off the computer and unplug the power cord from the power supply. After waiting for 15 seconds, use a jumper cap to short pin2 and pin3 on CLR CMOS1 for 5 seconds. However, please do not clear the CMOS right after you update the BIOS. If you need to clear the CMOS when you just finish updating the BIOS, you must boot up the system first, and then shut it down before you do the clear-CMOS action. Please be noted that the password, date, time, user default profile, 1394 GUID and MAC address will be cleared only if the CMOS battery is removed.



The Clear CMOS Switch has the same function as the Clear CMOS jumper.

---

## 2.11 Onboard Headers and Connectors



Onboard headers and connectors are NOT jumpers. Do NOT place jumper caps over these headers and connectors. Placing jumper caps over the headers and connectors will cause permanent damage of the motherboard!

---

### Serial ATA2 Connectors

(SATA2\_0\_1: see p.4, No. 13)

(SATA2\_2\_3: see p.4, No. 12)

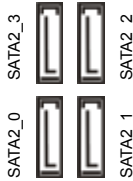

These four Serial ATA2 (SATA2) connectors support SATA data cables for internal storage devices. The current SATA2 interface allows up to 3.0 Gb/s data transfer rate.

---

### Serial ATA3 Connectors

(SATA3\_0\_1: see p.4, No. 14)

(SATA3\_M0\_M1: see p.4, No. 15)

(SATA3\_M2\_M3: see p.4, No. 16)

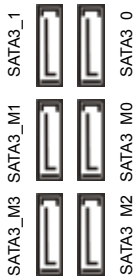

These six Serial ATA3 (SATA3) connectors support SATA data cables for internal storage devices. The current SATA3 interface allows up to 6.0 Gb/s data transfer rate.

---

### Serial ATA (SATA) Data Cable (Optional)



Either end of the SATA data cable can be connected to the SATA / SATA2 / SATA3 hard disk or the SATA2 / SATA3 connector on this motherboard.

---

### Serial ATA (SATA) Power Cable (Optional)

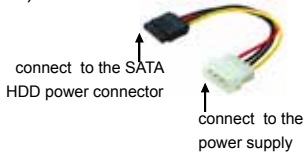

Please connect the black end of SATA power cable to the power connector on each drive. Then connect the white end of SATA power cable to the power connector of the power supply.

## USB 2.0 Headers

(9-pin USB\_6\_7)

(see p.4 No. 29)

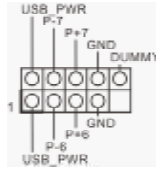

(9-pin USB\_8\_9)

(see p.4 No. 28)

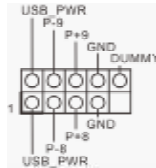

(9-pin USB\_10\_11)

(see p.4 No. 27)

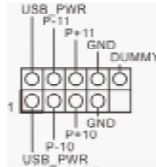

Besides six default USB 2.0 ports on the I/O panel, there are three USB 2.0 headers on this motherboard. Each USB 2.0 header can support two USB 2.0 ports.

## USB 3.0 Header

(19-pin USB3\_5\_6)

(see p.4 No. 8)

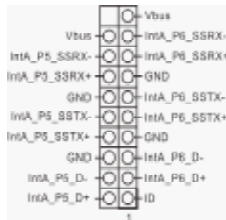

(19-pin USB3\_7\_8)

(see p.4 No. 9)

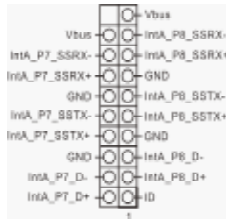

Besides four default USB 3.0 ports on the I/O panel, there are two USB 3.0 headers on this motherboard. Each USB 3.0 header can support two USB 3.0 ports.

## Infrared Module Header

(5-pin IR1)

(see p.4 No. 37)

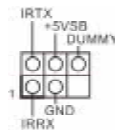

This header supports an optional wireless transmitting and receiving infrared module.

---

## Consumer Infrared Module Header

(4-pin CIR1)

(see p.4 No. 30)



This header can be used to connect the remote controller receiver.

---

## Front Panel Audio Header

(9-pin HD\_AUDIO1)

(see p.4 No. 35)

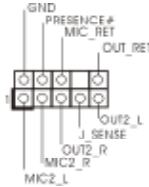

This is an interface for front panel audio cable that allows convenient connection and control of audio devices.



1. High Definition Audio supports Jack Sensing, but the panel wire on the chassis must support HDA to function correctly. Please follow the instruction in our manual and chassis manual to install your system.

2. If you use AC'97 audio panel, please install it to the front panel audio header as below:

A. Connect Mic\_IN (MIC) to MIC2\_L.

B. Connect Audio\_R (RIN) to OUT2\_R and Audio\_L (LIN) to OUT2\_L.

C. Connect Ground (GND) to Ground (GND).

D. MIC\_RET and OUT\_RET are for HD audio panel only. You don't need to connect them for AC'97 audio panel.

E. To activate the front mic.

For Windows® XP / XP 64-bit OS:

Select "Mixer". Select "Recorder". Then click "FrontMic".

For Windows® 7 / 7 64-bit / Vista™ / Vista™ 64-bit OS:

Go to the "FrontMic" Tab in the Realtek Control panel. Adjust "Recording Volume".

---

## System Panel Header

(9-pin PANEL1)

(see p.4 No. 22)

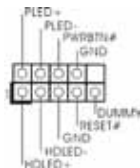

This header accommodates several system front panel functions.



Connect the power switch, reset switch and system status indicator on the chassis to this header according to the pin assignments below. Note the positive and negative pins before connecting the cables.

### **PWRBTN (Power Switch):**

Connect to the power switch on the chassis front panel. You may configure the way to turn off your system using the power switch.

**RESET (Reset Switch):**

Connect to the reset switch on the chassis front panel. Press the reset switch to restart the computer if the computer freezes and fails to perform a normal restart.

**PLED (System Power LED):**

Connect to the power status indicator on the chassis front panel. The LED is on when the system is operating. The LED keeps blinking when the system is in S1 sleep state. The LED is off when the system is in S3/S4 sleep state or powered off (S5).

**HDLED (Hard Drive Activity LED):**

Connect to the hard drive activity LED on the chassis front panel. The LED is on when the hard drive is reading or writing data.

The front panel design may differ by chassis. A front panel module mainly consists of power switch, reset switch, power LED, hard drive activity LED, speaker and etc. When connecting your chassis front panel module to this header, make sure the wire assignments and the pin assignments are matched correctly.

**Chassis Speaker Header**

(4-pin SPEAKER 1)  
(see p.4 No. 21)

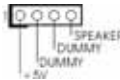

Please connect the chassis speaker to this header.

**Power LED Header**

(3-pin PLED1)  
(see p.4 No. 23)



Please connect the chassis power LED to this header to indicate system power status. The LED is on when the system is operating. The LED keeps blinking in S1 state. The LED is off in S3/S4 state or S5 state (power off).

**Chassis and Power Fan Connectors**

(4-pin CHA\_FAN1)  
(see p.4 No. 11)

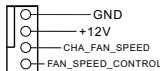

(3-pin CHA\_FAN2)  
(see p.4 No. 20)

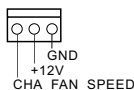

Please connect the fan cables to the fan connectors and match the black wire to the ground pin. CHA\_FAN1, CHA\_FAN2 and CHA\_FAN3 support Fan Control.



(3-pin CHA\_FAN3)  
(see p.4 No. 17)

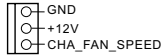

(3-pin PWR\_FAN1)  
(see p.4 No. 44)

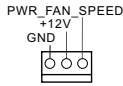

## CPU Fan Connectors

(4-pin CPU\_FAN1)  
(see p.4 No. 5)

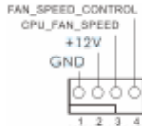

Please connect the CPU fan cable to the connector and match the black wire to the ground pin.



Though this motherboard provides 4-Pin CPU fan (Quiet Fan) support, the 3-Pin CPU fan still can work successfully even without the fan speed control function. If you plan to connect the 3-Pin CPU fan to the CPU fan connector on this motherboard, please connect it to Pin 1-3.

**Pin 1-3 Connected** ←



3-Pin Fan Installation

(3-pin CPU\_FAN2)  
(see p.4 No. 6)

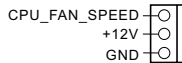

## ATX Power Connector

(24-pin ATXPWR1)  
(see p.4 No. 7)

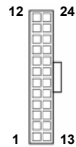

Please connect an ATX power supply to this connector.



Though this motherboard provides 24-pin ATX power connector, it can still work if you adopt a traditional 20-pin ATX power supply. To use the 20-pin ATX power supply, please plug your power supply along with Pin 1 and Pin 13.

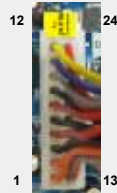

20-Pin ATX Power Supply Installation

ATX 12V Power Connector  
(8-pin ATX12V1)  
(see p.4 No. 3)

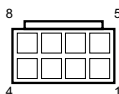

Please connect an ATX 12V power supply to this connector.



Though this motherboard provides 8-pin ATX 12V power connector, it can still work if you adopt a traditional 4-pin ATX 12V power supply. To use the 4-pin ATX power supply, please plug your power supply along with Pin 1 and Pin 5.

4-Pin ATX 12V Power Supply Installation



### SLI/XFIRE Power Connector

(4-pin SLI/XFIRE\_PWR1)

(see p.4 No. 31)



SLI/XFIRE\_POWER1

It is not necessary to use this connector, but please connect it with a hard disk power connector when two graphics cards are plugged to this motherboard.

### IEEE 1394 Header

(9-pin FRONT\_1394)

(see p.4 No. 34)

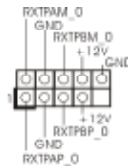

Besides one default IEEE 1394 port on the I/O panel, there is one IEEE 1394 header (FRONT\_1394) on this motherboard. This IEEE 1394 header can support one IEEE 1394 port.

### Serial port Header

(9-pin COM1)

(see p.4 No. 32)

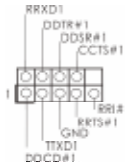

This COM1 header supports a serial port module.

### HDMI\_SPDIF Header

(2-pin HDMI\_SPDIF1)

(see p.4 No. 33)



HDMI\_SPDIF header, providing SPDIF audio output to HDMI VGA card, allows the system to connect HDMI Digital TV/ projector/LCD devices. Please connect the HDMI\_SPDIF connector of HDMI VGA card to this header.

---

## The Installation Guide of Front USB 3.0 Panel

**Step 1** Prepare the bundled Front USB 3.0 Panel, four HDD screws, and six chassis screws.



**Step 2** Screw the 2.5" HDD/SSD to the Front USB 3.0 Panel with four HDD screws.



**Step 3** Intall the Front USB 3.0 Panel into the 2.5" drive bay of the chassis.



**Step 4** Screw the Front USB 3.0 Panel to the drive bay with six chassis screws.



**Step 5** Plug the Front USB 3.0 cable into the USB 3.0 header (USB3\_5\_6 or USB3\_7\_8) on the motherboard.



**Step 6** The Front USB 3.0 Panel is ready to use.



## The Installation Guide of Rear USB 3.0 Bracket

**Step 1** Unscrew the two screws from the Front USB 3.0 Panel.



**Step 2** Put the USB 3.0 cable and the rear USB 3.0 bracket together.



**Step 3** Screw the two screws into the rear USB 3.0 bracket.



**Step 4** Put the rear USB 3.0 bracket into the chassis.



---

## 2.12 Smart Switches

The motherboard has three smart switches: power switch, reset switch and clear CMOS switch, allowing users to quickly turn on/off or reset the system to clear the CMOS values.

---

Power Switch  
(PWRBTN)  
(see p.4 No. 18)



Power Switch is a smart switch, allowing users to quickly turn on/off the system.

---

Reset Switch  
(RSTBTN)  
(see p.4 No. 19)



Reset Switch is a smart switch, allowing users to quickly reset the system.

---

Clear CMOS Switch  
(CLRBTN)  
(see p.5 No. 18)



Clear CMOS Switch is a smart switch, allowing users to quickly clear the CMOS values.

## 2.13 Dr. Debug

Dr. Debug is used to provide code information, which makes troubleshooting even easier. Please see the diagrams below for reading the Dr. Debug codes.

Status Code	Description
0x00	Not used
0x01	Power on. Reset type detection (soft/hard)
0x02	AP initialization before microcode loading
0x03	North Bridge initialization before microcode loading
0x04	South Bridge initialization before microcode loading
0x05	OEM initialization before microcode loading
0x06	Microcode loading
0x07	AP initialization after microcode loading
0x08	North Bridge initialization after microcode loading
0x09	South Bridge initialization after microcode loading
0x0A	OEM initialization after microcode loading
0x0B	Cache initialization
0x0C – 0x0D	Reserved for future AMI SEC error codes
0x0E	Microcode not found
0x0F	Microcode not loaded
0x10	PEI Core is started
0x11	Pre-memory CPU initialization is started
0x12	Pre-memory CPU initialization (CPU module specific)
0x13	Pre-memory CPU initialization (CPU module specific)
0x14	Pre-memory CPU initialization (CPU module specific)
0x15	Pre-memory North Bridge initialization is started
0x16	Pre-Memory North Bridge initialization (North Bridge module specific)
0x17	Pre-Memory North Bridge initialization (North Bridge module specific)
0x18	Pre-Memory North Bridge initialization (North Bridge module specific)
0x19	Pre-memory South Bridge initialization is started
0x1A	Pre-memory South Bridge initialization (South Bridge module specific)
0x1B	Pre-memory South Bridge initialization (South Bridge module specific)
0x1C	Pre-memory South Bridge initialization (South Bridge module specific)
0x1D – 0x2A	OEM pre-memory initialization codes
0x2B	Memory initialization. Serial Presence Detect (SPD) data reading
0x2C	Memory initialization. Memory presence detection
0x2D	Memory initialization. Programming memory timing information
0x2E	Memory initialization. Configuring memory
0x2F	Memory initialization (other)
0x30	Reserved for ASL
0x31	Memory Installed
0x32	CPU post-memory initialization is started
0x33	CPU post-memory initialization. Cache initialization
0x34	CPU post-memory initialization. Application Processor(s) (AP) initialization
0x35	CPU post-memory initialization. Boot Strap Processor (BSP) selection
0x36	CPU post-memory initialization. System Management Mode (SMM) initialization

0x37	Post-Memory North Bridge initialization is started
0x38	Post-Memory North Bridge initialization (North Bridge module specific)
0x39	Post-Memory North Bridge initialization (North Bridge module specific)
0x3A	Post-Memory North Bridge initialization (North Bridge module specific)
0x3B	Post-Memory South Bridge initialization is started
0x3C	Post-Memory South Bridge initialization (South Bridge module specific)
0x3D	Post-Memory South Bridge initialization (South Bridge module specific)
0x3E	Post-Memory South Bridge initialization (South Bridge module specific)
0x3F-0x4E	OEM post memory initialization codes
0x4F	DXE IPL is started
0x50	Memory initialization error. Invalid memory type or incompatible memory speed
0x51	Memory initialization error. SPD reading has failed
0x52	Memory initialization error. Invalid memory size or memory modules do not match
0x53	Memory initialization error. No usable memory detected
0x54	Unspecified memory initialization error
0x55	Memory not installed
0x56	Invalid CPU type or Speed
0x57	CPU mismatch
0x58	CPU self test failed or possible CPU cache error
0x59	CPU micro-code is not found or micro-code update is failed
0x5A	Internal CPU error
0x5B	reset PPI is not available
0x5C-0x5F	Reserved for future AMI error codes
0xE0	S3 Resume is started (S3 Resume PPI is called by the DXE IPL)
0xE1	S3 Boot Script execution
0xE2	Video repost
0xE3	OS S3 wake vector call
0xE4-0xE7	Reserved for future AMI progress codes
0xE8	S3 Resume Failed
0xE9	S3 Resume PPI not Found
0xEA	S3 Resume Boot Script Error
0xEB	S3 OS Wake Error
0xEC-0xEF	Reserved for future AMI error codes
0xF0	Recovery condition triggered by firmware (Auto recovery)
0xF1	Recovery condition triggered by user (Forced recovery)
0xF2	Recovery process started
0xF3	Recovery firmware image is found
0xF4	Recovery firmware image is loaded
0xF5-0xF7	Reserved for future AMI progress codes
0xF8	Recovery PPI is not available
0xF9	Recovery capsule is not found
0xFA	Invalid recovery capsule
0xFB – 0xFF	Reserved for future AMI error codes
0x60	DXE Core is started
0x61	NVRAM initialization

0x62	Installation of the South Bridge Runtime Services
0x63	CPU DXE initialization is started
0x64	CPU DXE initialization (CPU module specific)
0x65	CPU DXE initialization (CPU module specific)
0x66	CPU DXE initialization (CPU module specific)
0x67	CPU DXE initialization (CPU module specific)
0x68	PCI host bridge initialization
0x69	North Bridge DXE initialization is started
0x6A	North Bridge DXE SMM initialization is started
0x6B	North Bridge DXE initialization (North Bridge module specific)
0x6C	North Bridge DXE initialization (North Bridge module specific)
0x6D	North Bridge DXE initialization (North Bridge module specific)
0x6E	North Bridge DXE initialization (North Bridge module specific)
0x6F	North Bridge DXE initialization (North Bridge module specific)
0x70	South Bridge DXE initialization is started
0x71	South Bridge DXE SMM initialization is started
0x72	South Bridge devices initialization
0x73	South Bridge DXE Initialization (South Bridge module specific)
0x74	South Bridge DXE Initialization (South Bridge module specific)
0x75	South Bridge DXE Initialization (South Bridge module specific)
0x76	South Bridge DXE Initialization (South Bridge module specific)
0x77	South Bridge DXE Initialization (South Bridge module specific)
0x78	ACPI module initialization
0x79	CSM initialization
0x7A – 0x7F	Reserved for future AMI DXE codes
0x80 – 0x8F	OEM DXE initialization codes
0x90	Boot Device Selection (BDS) phase is started
0x91	Driver connecting is started
0x92	PCI Bus initialization is started
0x93	PCI Bus Hot Plug Controller Initialization
0x94	PCI Bus Enumeration
0x95	PCI Bus Request Resources
0x96	PCI Bus Assign Resources
0x97	Console Output devices connect
0x98	Console input devices connect
0x99	Super IO Initialization
0x9A	USB initialization is started
0x9B	USB Reset
0x9C	USB Detect
0x9D	USB Enable
0x9E – 0x9F	Reserved for future AMI codes
0xA0	IDE initialization is started
0xA1	IDE Reset
0xA2	IDE Detect
0xA3	IDE Enable
0xA4	SCSI initialization is started
0xA5	SCSI Reset

0xA6	SCSI Detect
0xA7	SCSI Enable
0xA8	Setup Verifying Password
0xA9	Start of Setup
0xAA	Reserved for ASL
0xAB	Setup Input Wait
0xAC	Reserved for ASL
0xAD	Ready To Boot event
0xAE	Legacy Boot event
0xAF	Exit Boot Services event
0xB0	Runtime Set Virtual Address MAP Begin
0xB1	Runtime Set Virtual Address MAP End
0xB2	Legacy Option ROM Initialization
0xB3	System Reset
0xB4	USB hot plug
0xB5	PCI bus hot plug
0xB6	Clean-up of NVRAM
0xB7	Configuration Reset (reset of NVRAM settings)
0xB8 – 0xBF	Reserved for future AMI codes
0xC0 – 0xCF	OEM BDS initialization codes
0xD0	CPU initialization error
0xD1	North Bridge initialization error
0xD2	South Bridge initialization error
0xD3	Some of the Architectural Protocols are not available
0xD4	PCI resource allocation error. Out of Resources
0xD5	No Space for Legacy Option ROM
0xD6	No Console Output Devices are found
0xD7	No Console Input Devices are found
0xD8	Invalid password
0xD9	Error loading Boot Option (LoadImage returned error)
0xDA	Boot Option is failed (StartImage returned error)
0xDB	Flash update is failed
0xDC	Reset protocol is not available



---

## 2.14 Driver Installation Guide

To install the drivers to your system, please insert the support CD to your optical drive first. Then, the drivers compatible to your system can be auto-detected and listed on the support CD driver page. Please follow the order from up to bottom side to install those required drivers. Therefore, the drivers you install can work properly.

## 2.15 Installing Windows® 7 / 7 64-bit / Vista™ / Vista™ 64-bit With RAID Functions

If you want to install Windows® 7 / 7 64-bit / Vista™ / Vista™ 64-bit on your SATA / SATA2 / SATA3 HDDs with RAID functions, please refer to the document at the following path in the Support CD for detailed procedures:

..\ RAID Installation Guide

## 2.16 Installing Windows® 7 / 7 64-bit / Vista™ / Vista™ 64-bit / XP / XP 64-bit Without RAID Functions

If you want to install Windows® 7 / 7 64-bit / Vista™ / Vista™ 64-bit / XP / XP 64-bit OS on your SATA / SATA2 / SATA3 HDDs without RAID functions, please follow below procedures according to the OS you install.

### 2.16.1 Installing Windows® XP / XP 64-bit Without RAID Functions

If you want to install Windows® XP / XP 64-bit OS on your SATA / SATA2 / SATA3 HDDs without RAID functions, please follow below steps.

#### Using SATA / SATA2 / SATA3 HDDs without NCQ function

##### STEP 1: Set Up UEFI.

A. Enter UEFI SETUP UTILITY → Advanced screen → Storage Configuration.

B. Set the option "SATA Mode" to [IDE]. (For SATA2\_0 to SATA2\_3, SATA3\_0 and SATA3\_1 ports.)

Set the options "Marvell 9172 SATA3\_M0\_M1 Operation Mode", "Marvell 9172 SATA3\_M2\_M3 Operation Mode" and "Marvell 9172 eSATA3\_0\_1 Operation Mode" to [IDE].

##### STEP 2: Install Windows® XP / XP 64-bit OS on your system.

---

## 2.16.2 Installing Windows® 7 / 7 64-bit / Vista™ / Vista™ 64-bit Without RAID Functions

If you want to install Windows® 7 / 7 64-bit / Vista™ / Vista™ 64-bit OS on your SATA / SATA2 / SATA3 HDDs without RAID functions, please follow below steps.

### Using SATA / SATA2 / SATA3 HDDs with NCQ function

#### STEP 1: Set Up UEFI.

- A. Enter UEFI SETUP UTILITY → Advanced screen → Storage Configuration.
- B. Set the option “SATA Mode” to [AHCI]. (For SATA2\_0 to SATA2\_3, SATA3\_0 and SATA3\_1 ports.)  
Set the options “Marvell 9172 SATA3\_M0\_M1 Operation Mode”, “Marvell 9172 SATA3\_M2\_M3 Operation Mode” and “Marvell 9172 eSATA3\_0\_1 Operation Mode” to [AHCI].

#### STEP 2: Install Windows® 7 / 7 64-bit / Vista™ / Vista™ 64-bit OS on your system.

### Using SATA / SATA2 / SATA3 HDDs without NCQ function

#### STEP 1: Set Up UEFI.

- A. Enter UEFI SETUP UTILITY → Advanced screen → Storage Configuration.
- B. Set the option “SATA Mode” to [IDE]. (For SATA2\_0 to SATA2\_3, SATA3\_0 and SATA3\_1 ports.)  
Set the options “Marvell 9172 SATA3\_M0\_M1 Operation Mode”, “Marvell 9172 SATA3\_M2\_M3 Operation Mode” and “Marvell 9172 eSATA3\_0\_1 Operation Mode” to [IDE].

#### STEP 2: Install Windows® 7 / 7 64-bit / Vista™ / Vista™ 64-bit OS on your system.

## 2.17 Untied Overclocking Technology

This motherboard supports Untied Overclocking Technology, which means during overclocking, BCLK enjoys better margin due to fixed PCI / PCIE buses. Before you enable Untied Overclocking function, please enter “Overclock Mode” option of UEFI setup to set the selection from [Auto] to [Manual]. Therefore, BCLK is untied during overclocking, but PCI / PCIE buses are in the fixed mode so that BCLK can operate under a more stable overclocking environment.



Please refer to the warning on page 11 for the possible overclocking risk before you apply Untied Overclocking Technology.

---

### 3. BIOS Information

The Flash Memory on the motherboard stores BIOS Setup Utility. When you start up the computer, please press <F2> or <Del> during the Power-On-Self-Test (POST) to enter BIOS Setup utility; otherwise, POST continues with its test routines. If you wish to enter BIOS Setup after POST, please restart the system by pressing <Ctl> + <Alt> + <Delete>, or pressing the reset button on the system chassis. The BIOS Setup program is designed to be user-friendly. It is a menu-driven program, which allows you to scroll through its various sub-menus and to select among the pre-determined choices. For the detailed information about BIOS Setup, please refer to the User Manual (PDF file) contained in the Support CD.

### 4. Software Support CD information

This motherboard supports various Microsoft® Windows® operating systems: 7 / 7 64-bit / Vista™ / Vista™ 64-bit / XP / XP 64-bit. The Support CD that came with the motherboard contains necessary drivers and useful utilities that will enhance motherboard features. To begin using the Support CD, insert the CD into your CD-ROM drive. It will display the Main Menu automatically if "AUTORUN" is enabled in your computer. If the Main Menu does not appear automatically, locate and double-click on the file "ASSETUP.EXE" from the BIN folder in the Support CD to display the menus.

---

# 1. Einführung

Wir danken Ihnen für den Kauf des **Fatal1ty X79 Professional Series** Motherboard, ein zuverlässiges Produkt, welches unter den ständigen, strengen Qualitätskontrollen von ASRock gefertigt wurde. Es bietet Ihnen exzellente Leistung und robustes Design, gemäß der Verpflichtung von ASRock zu Qualität und Halbarkeit. Diese Schnellinstallationsanleitung führt in das Motherboard und die schrittweise Installation ein. Details über das Motherboard finden Sie in der Bedienungsanleitung auf der Support-CD.



Da sich Motherboard-Spezifikationen und BIOS-Software verändern können, kann der Inhalt dieses Handbuchs ebenfalls jederzeit geändert werden. Für den Fall, dass sich Änderungen an diesem Handbuch ergeben, wird eine neue Version auf der ASRock-Website, ohne weitere Ankündigung, verfügbar sein. Die neuesten Grafikkarten und unterstützten CPUs sind auch auf der ASRock-Website aufgelistet.

ASRock-Website: <http://www.asrock.com>

Wenn Sie technische Unterstützung zu Ihrem Motherboard oder spezifische Informationen zu Ihrem Modell benötigen, besuchen Sie bitte unsere Webseite: [www.asrock.com/support/index.asp](http://www.asrock.com/support/index.asp)

## 1.1 Kartoninhalt

**Fatal1ty X79 Professional Series** Motherboard

(ATX-Formfaktor: 30.5 cm x 24.4 cm; 12.0 Zoll x 9.6 Zoll)

**Fatal1ty X79 Professional Series** Schnellinstallationsanleitung

**Fatal1ty X79 Professional Series** Support-CD

Sechs Serial ATA (SATA) -Datenkabel (optional)

Zwei Serial ATA (SATA) -Festplattenstromkabel (optional)

Ein I/O Shield

Ein USB 3.0-Frontblende

Vier Festplatte Schrauben

Sechs Gehäuses Schrauben

Ein USB 3.0-Blech an der Rückwand

Zwei ASRock SLI\_Bridge Karte

Ein ASRock SLI\_Bridge\_3S-Karte

Ein ASRock 3-Wege-SLI-Brücke-Karte



### **ASRock erinnert...**

Zur besseren Leistung unter Windows® 7 / 7, 64 Bit / Vista™ / Vista™ 64 Bit empfehlen wir, die Speicherkonfiguration im BIOS auf den AHCI-Modus einzustellen. Hinweise zu den BIOS-Einstellungen finden Sie in der Bedienungsanleitung auf der mitgelieferten CD.

## 1.2 Spezifikationen

<b>Plattform</b>	<ul style="list-style-type: none"> <li>- ATX-Formfaktor: 30.5 cm x 24.4 cm; 12.0 Zoll x 9.6 Zoll</li> <li>- Hochwertiges Gold-Kondensatordesign (100 % hochwertige japanische Fertigung leitfähiger Polymerkondensatoren)</li> </ul>
<b>CPU</b>	<ul style="list-style-type: none"> <li>- Unterstützt Prozessoren der Intel® Core™ i7-Familie für LGA 2011-Sockel</li> <li>- Digi Power-Design</li> <li>- Erweitertes 16 + 2-Stromphasen Design</li> <li>- Unterstützt Intel® Turbo Boost 2.0-Technologie</li> <li>- Unterstützt Hyper-Threading-Technologie (siehe <b>VORSICHT 1</b>)</li> <li>- Unterstützt Untied-Übertaktungstechnologie</li> </ul>
<b>Chipsatz</b>	<ul style="list-style-type: none"> <li>- Intel® X79</li> </ul>
<b>Speicher</b>	<ul style="list-style-type: none"> <li>- Vierkanal-DDR3-Speichertechnologie (siehe <b>VORSICHT 2</b>)</li> <li>- 4 x Steckplätze für DDR3</li> <li>- Unterstützt DDR3 2400+(OC)/2133(OC)/1866(OC)/1600/1333/1066 non-ECC, ungepufferter Speicher</li> <li>- Unterstützt in DDR3 ECC (ungepufferten Speicher) mit Prozessoren der Intel® Workstation 1S Xeon® E5 16xx-/26XX/46xx-Serie in Sockel LGA 2011</li> <li>- Max. Kapazität des Systemspeichers: 32GB (siehe <b>VORSICHT 3</b>)</li> <li>- Unterstützt Intel® Extreme Memory Profile (XMP)1.3/1.2</li> </ul>
<b>Erweiterungssteckplätze</b>	<ul style="list-style-type: none"> <li>- 4 x PCI-Express-3.0-x16-Steckplätze (PCIe1/PCIe2/PCIe4/PCIe5: x16/8/16/0-Modus und x16/8/8/8-Modus) (siehe <b>VORSICHT 4</b>)</li> <li>- 1 x PCI Express 2.0 x1-Steckplätze</li> <li>- 2 x PCI -Steckplätze</li> <li>- Unterstützt AMD Quad CrossFireX™, 4-Way CrossFireX™, 3-Way CrossFireX™ und CrossFireX™</li> <li>- NVIDIA® Quad SLI™, 4-Way SLI™, 3-Way SLI™ und SLI™</li> </ul>
<b>Audio</b>	<ul style="list-style-type: none"> <li>- 7.1 CH HD Audio mit dem Inhalt Schutz (Realtek ALC898 Audio Codec)</li> <li>- Premium Blu-ray-Audio-Unterstützung</li> <li>- Unterstützt THX TruStudio™</li> </ul>
<b>LAN</b>	<ul style="list-style-type: none"> <li>- PCIe x1 Gigabit LAN 10/100/1000 Mb/s</li> <li>- Broadcom BCM57781</li> <li>- Unterstützt Wake-On-LAN</li> <li>- Unterstützt energieeffizientes Ethernet 802.3az</li> </ul>

	- Unterstützt PXE
<b>E/A-Anschlüsse an der Rückseite</b>	<p>I/O Panel</p> <ul style="list-style-type: none"> <li>- 1 x PS/2-Tastaturanschluss</li> <li>- 1 x Koaxial-SPDIF-Ausgang</li> <li>- 1 x optischer SPDIF-Ausgang</li> <li>- 5 x Standard-USB 2.0-Anschlüsse</li> <li>- 1 x Fatal1ty Mausanschluss (USB 2.0)</li> <li>- 2 x eSATA3-Anschlüsse</li> <li>- 4 x Standard-USB 3.0-Anschlüsse</li> <li>- 1 x RJ-45 LAN Port mit LED (ACT/LINK LED und SPEED LED)</li> <li>- 1 x IEEE 1394 Port</li> <li>- 1 x CMOS löschen-Schalter</li> <li>- HD Audiobuchse: Lautsprecher seitlich / Lautsprecher hinten / Mitte/Bass / Audioeingang/ Lautsprecher vorne / Mikrofon (siehe <b>VORSICHT 5</b>)</li> </ul>
<b>SATA3</b>	<ul style="list-style-type: none"> <li>- 2 x SATA 3-Anschlüsse (6,0 Gb/s); unterstützt RAID- (RAID 0, RAID 1, RAID 5, RAID 10 und Intel Rapid Storage3.0), NCQ-, AHCI-und „Hot Plug“-Funktionen</li> <li>- 4 x SATA 3-Anschlüsse (6,0 Gb/s) durch Marvell SE9172; unterstützt RAID- (RAID 0 und RAID 1), NCQ-, AHCI-und „Hot Plug“-Funktionen</li> </ul>
<b>USB3.0</b>	<ul style="list-style-type: none"> <li>- 4 x USB 3.0-Ports an der Rückseite durch TI<sup>®</sup>, unterstützt USB 1.0/2.0/3.0 mit bis zu 5 Gb/s</li> <li>- 2 x USB 3.0-Header (unterstützt vier USB 3.0-Ports) an der Vorderseite durch TI<sup>®</sup>, unterstützt USB 1.0/2.0/3.0 mit bis zu 5 Gb/s</li> </ul>
<b>Anschlüsse</b>	<ul style="list-style-type: none"> <li>- 4 x SATA2 3,0 GB/s-Anschlüsse, unterstützen RAID- (RAID 0, RAID 1, RAID 5, RAID 10 und Intel Rapid Storage3.0), NCQ-, AHCI-und „Hot Plug“-Funktionen</li> <li>- 6 x SATA3 6,0 GB/s-Anschlüsse</li> <li>- 1 x Infrarot-Modul-Header</li> <li>- 1 x Consumer Infrared-Modul-Header</li> <li>- 1 x COM-Anschluss-Header</li> <li>- 1 x HDMI_SPDIF-Anschluss</li> <li>- 1 x IEEE 1394-Anschluss</li> <li>- 1 x Betriebs-LED-Header</li> <li>- CPU/Gehäuse/Strom Lüfter-Anschluss</li> <li>- 24-pin ATX-Netz-Header</li> <li>- 8-pin anschluss für 12V-ATX-Netzteil</li> <li>- SLI/XFIRE-Netz-Header</li> </ul>

	<ul style="list-style-type: none"> <li>- Anschluss für Audio auf der Gehäusevorderseite</li> <li>- 3 x USB 2.0-Anschlüsse (Unterstützung 6 zusätzlicher USB 2.0-Anschlüsse)</li> <li>- 2 x USB 3.0-Anschlüsse (Unterstützung 4 zusätzlicher USB 3.0-Anschlüsse)</li> <li>- 1 x Dr. Debug (Debug-LED mit 7 Segmenten)</li> </ul>
<b>Schnellschalter</b>	<ul style="list-style-type: none"> <li>- 1 x CMOS löschen-Schalter mit LED</li> <li>- 1 x Netzschalter mit LED</li> <li>- 1 x Rücksetzschalter (Reset) mit LED</li> </ul>
<b>BIOS</b>	<ul style="list-style-type: none"> <li>- 64Mb AMIs Legal BIOS UEFI mit GUI-Unterstützung</li> <li>- Unterstützung für "Plug and Play"</li> <li>- ACPI 1.1-Weckfunktionen</li> <li>- JumperFree-Modus</li> <li>- SMBIOS 2.3.1</li> <li>- CPU, VCCSA, DRAM, VTT, CPU PLL, PCH1.1V, PCH1.5V Stromspannung Multianpassung</li> </ul>
<b>CD d'assistance</b>	<ul style="list-style-type: none"> <li>- Treiber, Dienstprogramme, Antivirussoftware (Probeversion), CyberLink MediaEspresso 6.5-Testversion, ASRock Software-Suite (ASRock MAGIX-Multimedia-Suite - OEM)</li> </ul>
<b>Einzigartige Eigenschaft</b>	<ul style="list-style-type: none"> <li>- F-Stream (siehe <b>VORSICHT 6</b>)</li> <li>- ASRock Sofortstart</li> <li>- ASRock Instant Flash (siehe <b>VORSICHT 7</b>)</li> <li>- ASRock APP Charger (siehe <b>VORSICHT 8</b>)</li> <li>- ASRock SmartView (siehe <b>VORSICHT 9</b>)</li> <li>- ASRock XFast USB (siehe <b>VORSICHT 10</b>)</li> <li>- ASRock XFast LAN (siehe <b>VORSICHT 11</b>)</li> <li>- ASRock XFast-Ladegerät (siehe <b>VORSICHT 12</b>)</li> <li>- ASRock XFast RAM (siehe <b>VORSICHT 13</b>)</li> <li>- ASRock Crashless BIOS (siehe <b>VORSICHT 14</b>)</li> <li>- Hybrid Booster: <ul style="list-style-type: none"> <li>- Schrittlöser CPU-Frequenz-Kontrolle (siehe <b>VORSICHT 15</b>)</li> <li>- ASRock U-COP (siehe <b>VORSICHT 16</b>)</li> <li>- Boot Failure Guard (B.F.G. – Systemstartfehlerschutz)</li> </ul> </li> <li>- Gute Nacht-LED</li> </ul>
<b>Hardware Monitor</b>	<ul style="list-style-type: none"> <li>- Überwachung der CPU-Temperatur</li> <li>- Motherboardtemperaturerkennung</li> <li>- Drehzahlmessung für CPU/Gehäuse/Strom Lüfter</li> <li>- Geräuscharmer CPU-/Gehäuselüfter (ermöglicht die automatische Anpassung der Gehäuselüftergeschwindigkeit durch CPU-Temperatur)</li> </ul>

	<ul style="list-style-type: none"> <li>- Mehrstufige Geschwindigkeitssteuerung für CPU/Gehäuse Lüfter</li> <li>- Spannungsüberwachung: +12V, +5V, +3.3V, Vcore</li> </ul>
<b>Betriebssysteme</b>	<ul style="list-style-type: none"> <li>- Unterstützt Microsoft® Windows® 7 / 7 64-Bit / Vista™ / Vista™ 64-Bit / XP / XP 64-Bit (siehe <b>VORSICHT 17</b>)</li> </ul>
<b>Zertifizierungen</b>	<ul style="list-style-type: none"> <li>- FCC, CE, WHQL</li> <li>- Gemäß Ökodesign-Richtlinie (ErP/EuP) (Stromversorgung gemäß Ökodesign-Richtlinie (ErP/EuP) erforderlich) (siehe <b>VORSICHT 18</b>)</li> </ul>

\* Für die ausführliche Produktinformation, besuchen Sie bitte unsere Website:  
<http://www.asrock.com>

### WARNUNG

Beachten Sie bitte, dass Overclocking, einschließlich der Einstellung im BIOS, Anwenden der Untied Overclocking-Technologie oder Verwenden von Overclocking-Werkzeugen von Dritten, mit einem gewissen Risiko behaftet ist. Overclocking kann sich nachteilig auf die Stabilität Ihres Systems auswirken oder sogar Komponenten und Geräte Ihres Systems beschädigen. Es geschieht dann auf eigene Gefahr und auf Ihre Kosten. Wir übernehmen keine Verantwortung für mögliche Schäden, die aufgrund von Overclocking verursacht wurden.

## VORSICHT!

1. Die Einstellung der "Hyper-Threading Technology", finden Sie auf Seite 67 des auf der Support-CD enthaltenen Benutzerhandbuches beschreiben.
2. Dieses Motherboard unterstützt vierkanal-DDR3-Speichertechnologie. Vor Implementierung der vierkanal-DDR3-Speichertechnologie müssen Sie die Installationsanleitung für die Speichermodule auf Seite 18 zwecks richtiger Installation gelesen haben.
3. Durch Betriebssystem-Einschränkungen kann die tatsächliche Speichergröße weniger als 4 GB betragen, da unter Windows® 7 / Vista™ / XP etwas Speicher zur Nutzung durch das System reserviert wird. Unter Windows® OS mit 64-Bit-CPU besteht diese Einschränkung nicht. Sie können ASRock XFast RAM zur Nutzung des Speichers, den Windows® nicht verwenden kann, einsetzen.
4. Aktuell unterstützt der Intel® Sandy Bridge-E-Sockel-2011-Prozessor PCIE 3.0 nicht; dieses Motherboard basiert jedoch bereits auf PCIE 3.0-Hardware. Die Aktivierung von PCIE 3.0 ist von der Intel-CPU



---

abhängig. Bitte suchen Sie auf der Intel-Webseite nach Informationen zu künftigen CPU-Aktualisierungen und -Veröffentlichungen.

5. Der Mikrofoneingang dieses Motherboards unterstützt Stereo- und Mono-Modi. Der Audioausgang dieses Motherboards unterstützt 2-Kanal-, 4-Kanal-, 6-Kanal- und 8-Kanal-Modi. Stellen Sie die richtige Verbindung anhand der Tabelle auf Seite 5 her.
6. F-Stream ist ein Alles-in-einem-Werkzeug zur Feineinstellung verschiedener Systemfunktionen an einer benutzerfreundlichen Schnittstelle; diese beinhaltet Hardware-Überwachung, Lüftersteuerung, Übertaktung, OC DNA und IES. Über die Hardware-Überwachung können Sie die Hauptsystemdaten einsehen. Die Lüftersteuerung zeigt Ihnen zur Anpassung Lüftergeschwindigkeit und Temperatur an. Bei der Übertaktung können Sie die CPU-Frequenz zur Erzielung optimaler Systemleistung übertakten. OC DNA ermöglicht Ihnen die Speicherung Ihrer OC-Einstellungen als Profil, welches Sie mit Freunden teilen können. Ihre Freunde können das OC-Profil dann in ihrem System laden und so die gleichen OC-Einstellungen erzielen. Per IES (Intelligent Energy Saver) kann der Spannungsregulator bei Inaktivität der CPU-Kerne die Anzahl an Ausgangsphasen zur Steigerung der Effizienz reduzieren – ohne die Rechenleistung zu beeinträchtigen.
7. ASRock Instant Flash ist ein im Flash-ROM eingebettetes BIOS-Flash-Programm. Mithilfe dieses praktischen BIOS-Aktualisierungswerkzeugs können Sie das System-BIOS aktualisieren, ohne dafür zuerst Betriebssysteme wie MS-DOS oder Windows® aufrufen zu müssen. Mit diesem Programm bekommen Sie durch Drücken der <F6>-Taste während des POST-Vorgangs oder durch Drücken der <F2>-Taste im BIOS-Setup-Menü Zugang zu ASRock Instant Flash. Sie brauchen dieses Werkzeug einfach nur zu starten und die neue BIOS-Datei auf Ihrem USB-Flash-Laufwerk, Diskettenlaufwerk oder der Festplatte zu speichern, und schon können Sie Ihr BIOS mit nur wenigen Klickvorgängen ohne Bereitstellung einer zusätzlichen Diskette oder eines anderen komplizierten Flash-Programms aktualisieren. Achten Sie darauf, dass das USB-Flash-Laufwerk oder die Festplatte das Dateisystem FAT32/16/12 benutzen muss.
8. Wenn Sie nach einer schnelleren, weniger eingeschränkten Möglichkeit zur Aufladung Ihrer Apple-Geräte (z. B. iPhone/iPad/iPod touch) suchen, bietet ASRock Ihnen eine wunderbare Lösung – den ASRock APP Charger. Installieren Sie einfach den ASRock APP Charger-Treiber; dadurch lädt sich Ihr iPhone wesentlich schneller über einen Computerauf – genau genommen bis zu 40 % schneller als zuvor. Der ASRock APP Charger ermöglicht Ihnen die schnelle Aufladung mehrerer Apple-Geräte gleichzeitig; der Ladevorgang wird sogar dann fortgesetzt, wenn der PC den Ruhezustand (S1), Suspend to RAM-Modus (S3) oder Tiefschlafmodus (S4) aufruft oder ausgeschaltet wird (S5). Nach der Installation des APP Charger-Treibers können Sie im Handumdrehen das großartigste Ladeerlebnis überhaupt genießen.

ASRock-Webseite: <http://www.asrock.com/Feature/AppCharger/index.asp>



9. SmartView, eine neue Internetbrowserfunktion, ist eine intelligente IE-Startseite, die meist besuchte Internetseiten, Ihren Browserverlauf, Facebook-Freunde und Nachrichten in Echtzeit miteinander kombiniert: In einer speziellen Ansicht, die das Internet noch angenehmer und aufregender macht. ASRock-Motherboards werden exklusiv mit der SmartView-Software geliefert, die auch dafür sorgt, dass Sie immer mit Ihren Freunden in Verbindung bleiben. Die SmartView-Funktionen können Sie mit den Windows®-Betriebssystemen 7 / 7, 64 Bit / Vista™ / Vista™ 64 Bit und dem Internet Explorer ab Version 8 nutzen.  
ASRock-Website: <http://www.asrock.com/Feature/SmartView/index.asp>
10. ASRocks XFast USB dient der Steigerung der Leistungsfähigkeit Ihrer USB-Speichergeräte. Die Leistung kann je nach Eigenschaften des Gerätes variieren.
11. ASRock XFast LAN bietet einen schnelleren Internetzugang mit den nachfolgenden Vorteilen. LAN-Anwendungspriorisierung: Hiermit konfigurieren Sie auf ideale Weise Ihre Anwendungspriorität und/oder fügen neue Programme hinzu. Niedrigere Latenzzeit bei Spielen: Nach Einstellung einer höheren Online-Gamepriorität kann hiermit die Latenzzeit bei Spielen herabgesetzt werden. Datenverkehrsgestaltung: Sie können Youtube-Videos in HD anzeigen und gleichzeitig Dateien herunterladen. Echtzeitanalyse Ihrer Daten: Über das Statusfenster können Sie schnell ermitteln, welche Datenströme zur Zeit übertragen werden.
12. Das ASRock XFast-Ladegerät bietet die beste und schnellste Technologie zur Aufladung Ihrer mobilen Geräte via PC. Über den USB-Port des XFast-Ladegerätes können Sie Ihre Geräte jederzeit in kürzester Zeit aufladen. Zusätzlich zu Apple-Geräten kann es auch intelligente Geräte mit dem BC 1.1-Standard aufladen. Hinweise finden Sie auf Seite 35.
13. ASRock XFast RAM ist eine neue Funktion, die beim F-Stream integriert ist. Sie ermöglicht die vollständige Nutzung des Speicherplatzes, der unter Windows®-Betriebssystemen mit 32-Bit-CPU nicht verwendet werden kann. ASRock XFast RAM verkürzt die Ladezeit zuvor besuchter Webseiten, was das Surfen im Internet mehr denn je beschleunigt. Auch die Arbeit mit Adobe Photoshop erfolgt fünfmal schneller. Ein weiterer Vorteil von ASRock XFast RAM liegt in der Reduzierung der Häufigkeit des Zugriffs auf SSDs bzw. HDDs zur Verlängerung deren Lebenszeit.
14. ASRock Crashless BIOS ermöglicht Benutzern die Aktualisierung ihres BIOS, ohne dass diese Fehler fürchten müssen. Falls während der BIOS-Aktualisierung ein Stromausfall auftritt, setzt ASRock Crashless BIOS die BIOS-Aktualisierung automatisch fort, sobald die Stromversorgung wiederhergestellt ist. Bitte beachten Sie, dass alle BIOS-Dateien zuerst im Stammverzeichnis Ihres USB-Datenträgers platziert werden müssen. Diese Funktion wird nur von USB 2.0-Ports unterstützt.
15. Obwohl dieses Motherboard stufenlose Steuerung bietet, wird Overclocking nicht empfohlen. Frequenzen, die über den für den jeweiligen Prozessor vorgesehenen liegen, können das System instabil werden lassen oder die CPU beschädigen.

- 
16. Wird eine Überhitzung der CPU registriert, führt das System einen automatischen Shutdown durch. Bevor Sie das System neu starten, prüfen Sie bitte, ob der CPU-Lüfter am Motherboard richtig funktioniert, und stecken Sie bitte den Stromkabelstecker aus und dann wieder ein. Um die Wärmeableitung zu verbessern, bitte nicht vergessen, etwas Wärmepaste zwischen CPU und Kühlkörper zu sprühen.
  17. Intel Rapid Storage Technology enterprise 3.0 und ASRock XFast RAM wird von Microsoft® Windows® XP / XP 64 Bit nicht unterstützt.
  18. EuP steht für Energy Using Product und kennzeichnet die Ökodesign-Richtlinie, die von der Europäischen Gemeinschaft zur Festlegung des Energieverbrauchs von vollständigen Systemen in Kraft gesetzt wurde. Gemäß dieser Ökodesign-Richtlinie (EuP) muss der gesamte Netzstromverbrauch von vollständigen Systemen unter 1,00 Watt liegen, wenn sie ausgeschaltet sind. Um dem EuP-Standard zu entsprechen, sind ein EuP-fähiges Motherboard und eine EuP-fähige Stromversorgung erforderlich. Gemäß einer Empfehlung von Intel muss eine EuP-fähige Stromversorgung dem Standard entsprechen, was bedeutet, dass bei einem Stromverbrauch von 100 mA die 5-Volt-Standby-Energieeffizienz höher als 50% sein sollte. Für die Wahl einer EuP-fähigen Stromversorgung empfehlen wir Ihnen, weitere Details beim Hersteller der Stromversorgung abzufragen.

### 1.3 Einstellung der Jumper

Die Abbildung verdeutlicht, wie Jumper gesetzt werden. Werden Pins durch Jumperkappen verdeckt, ist der Jumper "Gebrückt". Werden keine Pins durch Jumperkappen verdeckt, ist der Jumper "Offen". Die Abbildung zeigt einen 3-Pin Jumper dessen Pin1 und Pin2 "Gebrückt" sind, bzw. es befindet sich eine Jumper-Kappe auf diesen beiden Pins.



Jumper	Einstellung	Beschreibung
CMOS löschen (CLRCMOS1, 3-Pin jumper) (siehe S.4, No. 25)	<b>1_2</b>  Default-Einstellung	<b>2_3</b>  CMOS löschen

Hinweis: CLRCMOS1 ermöglicht Ihnen die Löschung der Daten im CMOS. Zum Löschen und Zurücksetzen der Systemparameter auf die Standardeinrichtung schalten Sie den Computer bitte aus und trennen das Netzkabel von der Stromversorgung. Warten Sie 15 Sekunden, schließen Sie dann Pin2 und Pin3 am CLRCMOS1 über einen Jumper fünf Sekunden lang kurz. Sie sollten das CMOS allerdings nicht direkt nach der BIOS-Aktualisierung löschen. Wenn Sie das CMOS nach Abschluss der BIOS-Aktualisierung löschen müssen, fahren Sie zuerst das System hoch. Fahren Sie es dann vor der CMOS-Löschung herunter. Bitte beachten Sie, dass Kennwort, Datum, Uhrzeit, benutzerdefiniertes Profil, 1394 GUID und MAC-Adresse nur gelöscht werden, wenn die CMOS-Batterie entfernt wird.



Der CMOS löschen-Schalter hat dieselbe Funktion wie der CMOS löschen-Jumper.

## 1.4 Integrierte Header und Anschlüsse



Integrierte Header und Anschlüsse sind KEINE Jumper. Setzen Sie KEINE Jumperkappen auf diese Header und Anschlüsse. Wenn Sie Jumperkappen auf Header und Anschlüsse setzen, wird das Motherboard unreparierbar beschädigt!

### Seriell-ATA2-Anschlüsse

(SATA2\_0\_1: siehe S.4 - No. 13)

(SATA2\_2\_3: siehe S.4 - No. 12)

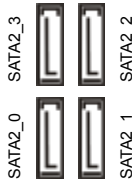

Diese vier Serial ATA2- (SATA2-)Verbinder unterstützten SATA-Datenkabel für interne Massenspeichergeräte. Die aktuelle SATA2- Schnittstelle ermöglicht eine Datenübertragungsrate bis 3,0 Gb/s.

### Seriell-ATA3-Anschlüsse

(SATA3\_0\_1: siehe S.4 - No. 14)

(SATA3\_M0\_M1: siehe S.4 - No. 15)

(SATA3\_M2\_M3: siehe S.4 - No. 16)

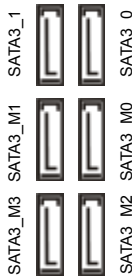

Diese sechs Serial ATA3- (SATA3-)Verbinder unterstützten SATA-Datenkabel für interne Massenspeichergeräte. Die aktuelle SATA3- Schnittstelle ermöglicht eine Datenübertragungsrate bis 6,0 Gb/s.

### Serial ATA- (SATA-)

Datenkabel

(Option)



Jedes Ende des SATA Datenkabels kann an die SATA / SATA2 / SATA3 Festplatte oder das SATA2 / SATA3 Verbindungsstück auf dieser Hauptplatine angeschlossen werden.

Serial ATA- (SATA-)  
Stromversorgungskabel  
(Option)

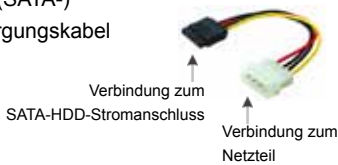

Verbinden Sie das schwarze Ende des SATA-Netzka-bels mit dem Netzanschluss am Laufwerk. Verbinden Sie dann das weiße Ende des SATA-Strom-versorgungskabels mit dem Stromanschluss des Netz-teils.

USB 2.0-Header  
(9-pol. USB\_6\_7)  
(siehe S.4 - No. 29)

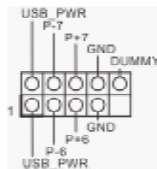

(9-pol. USB\_8\_9)  
(siehe S.4 - No. 28)

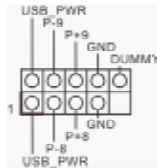

(9-pol. USB\_10\_11)  
(siehe S.4 - No. 27)

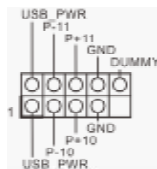

Zusätzlich zu den sechs üblichen USB 2.0-Ports an den I/O-Anschlüssen befinden sich drei USB 2.0- Anschlussleisten am Motherboard. Pro USB 2.0- Anschlussleiste werden zwei USB 2.0-Ports unterstützt.

USB 3.0-Header  
(19-pol. USB3\_5\_6)  
(siehe S.4 - No. 8)

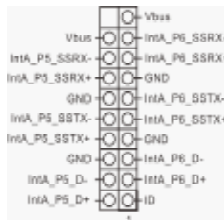

Neben vier Standard-USB 3.0-Ports am E/A-Panel befindet sich zwei USB 3.0-Header an diesem Motherboard. Pro USB 3.0- Anschlussleiste werden zwei USB 3.0-Ports unterstützt.

(19-pol. USB3\_7\_8)  
(siehe S.4 - No. 9)

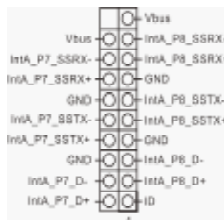

### Infrarot-Modul-Header

(5-pin IR1)

(siehe S.4 - No. 37)

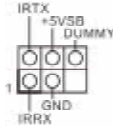

Dieser Header unterstützt ein optionales, drahtloses Sende- und Empfangs-Infrarotmodul.

### Consumer Infrared-Modul-Header

(4-pin CIR1)

(siehe S.4 - No. 30)



Dieser Header kann zum Anschließen Remote-Empfänger.

### Anschluss für Audio auf der Gehäusevorderseite

(9-Pin HD\_AUDIO1)

(siehe S.4 - No. 35)

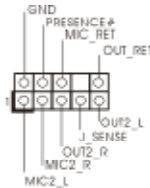

Dieses Interface zu einem Audio-Panel auf der Vorderseite Ihres Gehäuses, ermöglicht Ihnen eine bequeme Anschlussmöglichkeit und Kontrolle über Audio-Geräte.



1. High Definition Audio unterstützt Jack Sensing (automatische Erkennung falsch angeschlossener Geräte), wobei jedoch die Bildschirmverdrahtung am Gehäuse HDA unterstützen muss, um richtig zu funktionieren. Beachten Sie bei der Installation im System die Anweisungen in unserem Handbuch und im Gehäusehandbuch.
2. Wenn Sie die AC'97-Audibleiste verwenden, installieren Sie diese wie nachstehend beschrieben an der Front-Audioanschlussleiste:
  - A. Schließen Sie Mic\_IN (MIC) an MIC2\_L an.
  - B. Schließen Sie Audio\_R (RIN) an OUT2\_R und Audio\_L (LIN) an OUT2\_L an.
  - C. Schließen Sie Ground (GND) an Ground (GND) an.
  - D. MIC\_RET und OUT\_RET sind nur für den HD-Audioanschluss gedacht. Diese Anschlüsse müssen nicht an die AC'97-Audibleiste angeschlossen werden.
  - E. So aktivieren Sie das Mikrofon an der Vorderseite.  
Bei den Betriebssystemen Windows® XP / XP 64 Bit:  
Wählen Sie „Mixer“. Wählen Sie „Recorder“ (Rekorder). Klicken Sie dann auf „FrontMic“ (Vorderes Mikrofon).  
Bei den Betriebssystemen Windows® 7 / 7 64 Bit / Vista™ / Vista™ 64 Bit:  
Wählen Sie im Realtek-Bedienfeld die „FrontMic“ (Vorderes Mikrofon)-Registerkarte. Passen Sie die „Recording Volume“ (Aufnahmelautstärke) an.

### System Panel-Header

(9-pin PANEL1)

(siehe S.4 - No. 22)

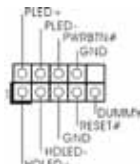

Dieser Header unterstützt mehrere Funktionen der Systemvorderseite.



Schließen Sie die Ein-/Austaste, die Reset-Taste und die Systemstatusanzeige am Gehäuse an diesen Header an; befolgen Sie dabei die nachstehenden Hinweise zur Pinbelegung. Beachten Sie die positiven und negativen Pins, bevor Sie die Kabel anschließen.

**PWRBTN (Ein-/Ausschalter):**

Zum Anschließen des Ein-/Ausschalters an der Frontblende des Gehäuses. Sie können konfigurieren, wie das System mit Hilfe des Ein-/Ausschalters ausgeschaltet werden können soll.

**RESET (Reset-Taste):**

Zum Anschließen der Reset-Taste an der Frontblende des Gehäuses. Mit der Reset-Taste können Sie den Computer im Falle eines Absturzes neu starten.

**PLED (Systembetriebs-LED):**

Zum Anschließen der Betriebsstatusanzeige an der Frontblende des Gehäuses. Die LED leuchtet, wenn das System in Betrieb ist. Die LED blinkt, wenn sich das System im Ruhezustand S1 befindet. Die LED schaltet sich aus, wenn sich das System in den Modi S3/S4 befindet oder ausgeschaltet ist (S5).

**HDLED (Festplattenaktivitäts-LED):**

Zum Anschließen der Festplattenaktivitäts-LED an der Frontblende des Gehäuses. Die LED leuchtet, wenn die Festplatte Daten liest oder schreibt.

Das Design der Frontblende kann je nach Gehäuse variieren. Ein Frontblendenmodul besteht hauptsächlich aus einer Ein-/Austaste, einer Reset-Taste, einer Betriebs-LED, einer Festplattenaktivitäts-LED, Lautsprechern, etc. Stellen Sie beim Anschließen des Frontblendenmoduls Ihres Gehäuses an diesem Header sicher, dass die Kabel- und Pinbelegung korrekt übereinstimmen.

Gehäuselautsprecher-Header

(4-pin SPEAKER1)  
(siehe S.4 - No. 21)

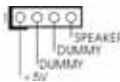

Schließen Sie den  
Gehäuselautsprecher an  
diesen Header an.



## Betriebs-LED-Header

(3-pin PLED1)

(siehe S.4 - No. 23)



Bitte schließen Sie die Betriebs-LED des Gehäuses zur Anzeige des Systembetriebsstatus an diesem Header an. Die LED leuchtet, wenn das System in Betrieb ist. Die LED blinkt im S1-Zustand. Im S3-/S4- oder S5-Zustand (ausgeschaltet) leuchtet die LED nicht.

## Gehäuse und Strom Lüfteranschlüsse

(4-pin CHA\_FAN1)

(siehe S.4, No. 11)

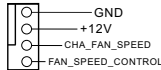

(3-pin CHA\_FAN2)

(siehe S.4 - No. 20)

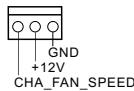

(3-pin CHA\_FAN3)

(siehe S.4 - No. 17)

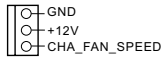

(3-pin PWR\_FAN1)

(siehe S.4 - No. 44)

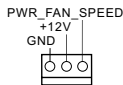

Verbinden Sie die Lüfterkabel mit den Lüfteranschlüssen, wobei der schwarze Draht an den Schutzleiterstift angeschlossen wird. CHA\_FAN 1/2/3-Lüftergeschwindigkeit kann über UEFI oder AXTU gesteuert werden. CHA\_FAN1-, CHA\_FAN2- und CHA\_FAN3-unterstützen Lüftersteuerung.

## CPU-Lüfteranschluss

(4-pin CPU\_FAN1)

(siehe S.4 - No. 5)

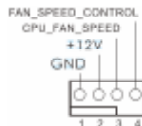

Verbinden Sie das CPU - Lüfterkabel mit diesem Anschluss und passen Sie den schwarzen Draht dem Erdungsstift an.



Obwohl dieses Motherboard einen vierpoligen CPU-Lüfteranschluss (Quiet Fan) bietet, können auch CPU-Lüfter mit dreipoligem Anschluss angeschlossen werden; auch ohne Geschwindigkeitsregulierung. Wenn Sie einen dreipoligen CPU-Lüfter an den CPU-Lüfteranschluss dieses Motherboards anschließen möchten, verbinden Sie ihn bitte mit den Pins 1 – 3.

**Pins 1–3 anschließen** ←

Lüfter mit dreipoligem Anschluss installieren

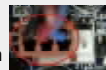

(3-pin CPU\_FAN2)  
(siehe S.4 - No. 6)

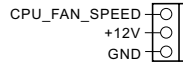

ATX-Netz-Header  
(24-pin ATXPWR1)  
(siehe S.4 - No. 7)

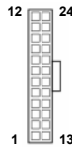

Verbinden Sie die ATX-Stromversorgung mit diesem Header.



Obwohl dieses Motherboard einen 24-pol. ATX-Stromanschluss bietet, kann es auch mit einem modifizierten traditionellen 20-pol. ATX-Netzteil verwendet werden. Um ein 20-pol. ATX-Netzteil zu verwenden, stecken Sie den Stecker mit Pin 1 und Pin 13 ein.

Installation eines 20-pol. ATX-Netzteils

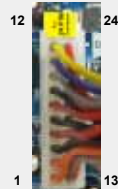

ATX 12V Anschluss  
(8-pin ATX12V1)  
(siehe S.4 - No. 3)

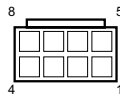

Bitte schließen Sie an diesen Anschluss die ATX 12V Stromversorgung an.



Obwohl diese Hauptplatine 8-Pin ATX 12V Stromanschluss zur Verfügung stellt, kann sie noch arbeiten, wenn Sie einen traditionellen 4-Pin ATX 12V Energieversorgung adoptieren. Um die 4-Pin ATX Energieversorgung zu verwenden, stecken Sie bitte Ihre Energieversorgung zusammen mit dem Pin 1 und Pin 5 ein.

Installation der 4-Pin ATX 12V Energieversorgung



SLI/XFIRE-Stromanschluss  
(4-pin SLI/XFIRE\_PWR1)  
(siehe S.4 - No. 31)



SLI/XFIRE\_POWER1

Sie müssen diesen Anschluss nicht zwingend verwenden. Wenn allerdings zwei Grafikkarten gleichzeitig am Motherboard angeschlossen sind, verbinden Sie diesen Anschluss bitte mit einem Festplatten-Stromversorgungsstecker.

---

## IEEE-1394 Header

(9-pin FRONT\_1394)

(siehe S.4 - No. 34)

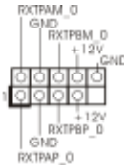

Außer einem vorgegebenem IEEE-1394 Port auf dem Ein-/ Ausgabe Panel, gibt es einen IEEE-1394 Header (FRONT\_1394) auf dieser Hauptplatine. Dieser IEEE-1394 Header kann einen IEEE-1394 Port unterstützen.

---

## COM-Anschluss-Header

(9-pin COM1)

(siehe S.4 - No. 32)

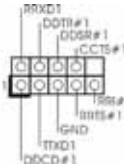

Dieser COM-Anschluss-Header wird verwendet, um ein COM-Anschlussmodul zu unterstützen.

---

## HDMI\_SPDIF-Anschluss

(2-pin HDMI\_SPDIF1)

(siehe S.4 - No. 33)



Der HDMI\_SPDIF-Anschluss stellt einen SPDIF-Audioausgang für eine HDMI-VGA-Karte zur Verfügung und ermöglicht den Anschluss von HDMI-Digitalgeräten wie Fernsehgeräten, Projektoren, LCD-Geräten an das System. Bitte verbinden Sie den HDMI\_SPDIF-Anschluss der HDMI-VGA-Karte mit diesem Anschluss.

## Installationsanleitung der USB 3.0-Frontblende

**Schritt 1** Halten Sie die mitgelieferte USB 3.0-Frontblende, vier Festplattenschrauben und sechs Gehäuseschrauben bereit.



**Schritt 2** Montieren Sie die 2,5 Zoll-HDD/SSD mit vier Festplattenschrauben an der USB 3.0-Frontblende.



**Schritt 3** Installieren Sie die USB 3.0-Frontblende im 2,5 Zoll-Festplatteneinschub des Gehäuses.



**Schritt 4** Montieren Sie die USB 3.0-Frontblende mit sechs Gehäuseschrauben am Festplatteneinschub.



**Schritt 5** Schließen Sie das Kabel der USB 3.0-Frontblende am USB 3.0-Header (USB3\_5\_6 oder USB3\_7\_8) am Motherboard an.



**Schritt 6** Die USB 3.0-Frontblende ist nun einsatzbereit.



## Installationsanleitung zum USB 3.0-Blech an der Rückwand

**Schritt 1** Lösen Sie die beiden Schrauben am USB 3.0-Panel.



**Schritt 2** Schließen Sie das USB 3.0-Kabel an das USB 3.0-Blech an.



**Schritt 3** Fixieren Sie das USB 3.0-Blech mit Schrauben an der Rückwand.



**Schritt 4** Setzen Sie das USB 3.0-Blech an der Rückwand des Gehäuses ein.



---

## 1.5 Schnellschalter

Dieses Motherboard besitzt drei Schnellschalter: Netzschalter, Rücksetzschalter (Reset) und CMOS löschen-Schalter, mit denen Benutzer das System schnell ein-/ausschalten oder zurücksetzen oder die CMOS-Werte löschen können.

---

### Netzschalter

(PWRBTN)

(siehe S.4 - No. 18)



Der Netzschalter ist ein Schnellschalter, mit dem Benutzer das System schnell ein-/ausschalten können.

---

### Rücksetzschalter (Reset)

(RSTBTN)

(siehe S.4 - No. 19)



Der Rücksetzschalter (Reset) ist ein Schnellschalter, mit dem Benutzer das System schnell zurücksetzen können.

---

### CMOS löschen-Schalter

(CLRBTN)

(siehe S.5 - No. 18)



Der CMOS löschen-Schalter ist ein Schnellschalter, mit dem Benutzer die CMOS-Werte schnell löschen können.

---

## 2. BIOS-Information

Das Flash Memory dieses Motherboards speichert das Setup-Utility. Drücken Sie <F2> oder <Del> während des POST (Power-On-Self-Test) um ins Setup zu gelangen, ansonsten werden die Testroutinen weiter abgearbeitet. Wenn Sie ins Setup gelangen wollen, nachdem der POST durchgeführt wurde, müssen Sie das System über die Tastenkombination <Ctrl> + <Alt> + <Delete> oder den Reset-Knopf auf der Gehäusevorderseite, neu starten. Natürlich können Sie einen Neustart auch durchführen, indem Sie das System kurz ab- und danach wieder anschalten.

Das Setup-Programm ist für eine bequeme Bedienung entwickelt worden. Es ist ein menügesteuertes Programm, in dem Sie durch unterschiedliche Untermenüs scrollen und die vorab festgelegten Optionen auswählen können. Für detaillierte Informationen zum BIOS-Setup, siehe bitte das Benutzerhandbuch (PDF Datei) auf der Support CD.

## 3. Software Support CD information

Dieses Motherboard unterstützt eine Reihe von Microsoft® Windows® Betriebssystemen: 7 / 7 64-Bit / Vista™ / Vista™ 64-Bit / XP / XP 64-Bit. Die Ihrem Motherboard beigelegte Support-CD enthält hilfreiche Software, Treiber und Hilfsprogramme, mit denen Sie die Funktionen Ihres Motherboards verbessern können. Legen Sie die Support-CD zunächst in Ihr CD-ROM-Laufwerk ein. Der Willkommensbildschirm mit den Installationsmenüs der CD wird automatisch aufgerufen, wenn Sie die "Autorun"-Funktion Ihres Systems aktiviert haben.

Erscheint der Willkommensbildschirm nicht, so "doppelklicken" Sie bitte auf das File ASSETUP.EXE im BIN-Verzeichnis der Support-CD, um die Menüs aufzurufen.

Das Setup-Programm soll es Ihnen so leicht wie möglich machen. Es ist menügesteuert, d.h. Sie können in den verschiedenen Untermenüs Ihre Auswahl treffen und die Programme werden dann automatisch installiert.

---

# 1. Introduction

Merci pour votre achat d'une carte mère **Fatal1ty X79 Professional Series**, une carte mère très fiable produite selon les critères de qualité rigoureux de ASRock. Elle offre des performances excellentes et une conception robuste conformément à l'engagement d'ASRock sur la qualité et la fiabilité au long terme.

Ce Guide d'installation rapide présente la carte mère et constitue un guide d'installation pas à pas. Des informations plus détaillées concernant la carte mère pourront être trouvées dans le manuel l'utilisateur qui se trouve sur le CD d'assistance.



Les spécifications de la carte mère et le BIOS ayant pu être mis à jour, le contenu de ce manuel est sujet à des changements sans notification. Au cas où n'importe quelle modification intervenait sur ce manuel, la version mise à jour serait disponible sur le site web ASRock sans nouvel avis. Vous trouverez les listes de prise en charge des cartes VGA et CPU également sur le site Web ASRock. Site web ASRock, <http://www.asrock.com> Si vous avez besoin de support technique en relation avec cette carte mère, veuillez consulter notre site Web pour de plus amples informations particulières au modèle que vous utilisez. [www.asrock.com/support/index.asp](http://www.asrock.com/support/index.asp)

## 1.1 Contenu du paquet

Carte mère **Fatal1ty X79 Professional Series**

(Facteur de forme ATX: 12.0 pouces x 9.6 pouces, 30.5 cm x 24.4 cm)

Guide d'installation rapide **Fatal1ty X79 Professional Series**

CD de soutien **Fatal1ty X79 Professional Series**

Six câbles de données de série ATA (SATA) (en option)

Deux câble d'alimentation de série ATA (SATA) HDD (en option)

Un I/O Panel Shield

Un panneau avant USB 3.0

Quatre HDD vis

Six châssis vis

Un support arrière USB 3.0

Deux carte Pont\_ASRock SLI

Un carte 3S\_Pont\_ASRock SLI

Un carte pont à trois voies SLI ASRock



### **ASRock vous rappelle...**

Pour bénéficier des meilleures performances sous Windows® 7 / 7 64 bits / Vista™ / Vista™ 64 bits, il est recommandé de paramétrer l'option BIOS dans Configuration de stockage en mode AHCI. Pour plus de détails sur l'installation BIOS, référez-vous au "Mode d'emploi" sur votre CD de support.

## 1.2 Spécifications

<b>Format</b>	<ul style="list-style-type: none"><li>- Facteur de forme ATX: 12.0 pouces x 9.6 pouces, 30.5 cm x 24.4 cm</li><li>- Design de condensateur Premium Gold (condensateurs polymère conducteur de qualité supérieure 100% fabriqués au Japon)</li></ul>
<b>CPU</b>	<ul style="list-style-type: none"><li>- Compatible avec la famille de processeurs Intel® Core™ i7 pour le socket LGA 2011</li><li>- Conception Digi Power</li><li>- Conception avancée 16 + 2 Power Phase</li><li>- Prend en charge la technologie Intel® Turbo Boost 2.0</li><li>- Prise en charge de la technologie Hyper-Threading (voir <b>ATTENTION 1</b>)</li><li>- Prend en charge la technologie Untied Overclocking</li></ul>
<b>Chipsets</b>	<ul style="list-style-type: none"><li>- Intel® X79</li></ul>
<b>Mémoire</b>	<ul style="list-style-type: none"><li>- Technologie de mémoire quadri-canal DDR3 (voir <b>ATTENTION 2</b>)</li><li>- 4 x slots DIMM DDR3</li><li>- Supporter DDR3 2400+(OC)/2133(OC)/1866(OC)/1600/1333/1066 non-ECC, sans amortissement mémoire</li><li>- Prend en charge la mémoire sans tampon DDR3 CCE, avec processeurs de la gamme Intel® Workstation 1S Xeon® E5 16xx/26xx/46xx sur socket LGA 2011</li><li>- Capacité maxi de mémoire système: 32GB (voir <b>ATTENTION 3</b>)</li><li>- Prend en charge le profil de mémoire extrême Intel® (XMP) 1.3/1.2</li></ul>
<b>Slot d'extension</b>	<ul style="list-style-type: none"><li>- 4 x slots PCI Express 3.0 x16 (PCIe1/PCIe2/PCIe4/PCIe5 : mode x16/8/16/0; mode x16/8/8/8) (voir <b>ATTENTION 4</b>)</li><li>- 1 x slot PCI Express 2.0 x1</li><li>- 2 x slots PCI</li><li>- Prend en charge AMD Quad CrossFireX™, 4-Way CrossFireX™, 3-Way CrossFireX™ et CrossFireX™</li><li>- Prend en charge NVIDIA® Quad SLI™, 4-Way SLI™, 3-Way SLI™ et SLI™</li></ul>
<b>Audio</b>	<ul style="list-style-type: none"><li>- 7,1 CH HD Audio avec protection de contenu (Realtek ALC898 Audio Codec)</li><li>- Prise en charge de l'audio Premium Blu-ray</li><li>- Prend en charge THX TruStudio™</li></ul>
<b>LAN</b>	<ul style="list-style-type: none"><li>- PCIe x1 Gigabit LAN 10/100/1000 Mb/s</li></ul>



	<ul style="list-style-type: none"> <li>- Broadcom BCM57781</li> <li>- Support du Wake-On-LAN</li> <li>- Prend en charge la norme Energy Efficient Ethernet (Ethernet à efficacité énergétique) 802.3az</li> <li>- Supporte PXE</li> </ul>
<b>Panneau arrière</b>	<p>I/O Panel</p> <ul style="list-style-type: none"> <li>- 1 x port clavier PS/2</li> <li>- 1 x port de sortie coaxial SPDIF</li> <li>- 1 x port de sortie optique SPDIF</li> <li>- 5 x ports USB 2.0 par défaut</li> <li>- 1 x Fatal1ty port souris (USB 2.0)</li> <li>- 2 x connecteurs eSATA3</li> <li>- 4 x ports USB 3.0 par défaut</li> <li>- 1 x port LAN RJ-45 avec LED (ACT/LED CLIGNOTANTE et LED VITESSE)</li> <li>- 1 x port IEEE 1394</li> <li>- 1 x interrupteur d'effacement du CMOS</li> <li>- Prise HD Audio: Haut-parleur latéral / Haut-parleur arrière / Central / Basses / Entrée Ligne / Haut-parleur frontal / Microphone (voir <b>ATTENTION 5</b>)</li> </ul>
<b>SATA3</b>	<ul style="list-style-type: none"> <li>- 2 x connecteurs SATA3 6,0 Gb/s par Intel® X79, prennent en charge les fonctions RAID (RAID 0, RAID 1, RAID 5, RAID 10 et Intel Rapid Storage3.0), NCQ, AHCI et « Hot Plug » (Branchement à chaud)</li> <li>- 4 x connecteurs SATA3 6,0 Gb/s par Marvell SE9172, prennent en charge les fonctions RAID (RAID 0 et RAID 1), NCQ, AHCI et « Hot Plug » (Branchement à chaud)</li> </ul>
<b>USB 3.0</b>	<ul style="list-style-type: none"> <li>- 2 x ports USB3.0 à l'arrière par TI®, prennent en charge USB 1.0/2.0/3.0 jusqu'à 5Gb/s</li> <li>- 1 x barrette USB3.0 en façade (prend en charge 2 ports USB 3.0) par TI®, prend en charge USB 1.0/2.0/3.0 jusqu'à 5Gb/s</li> </ul>
<b>Connecteurs</b>	<ul style="list-style-type: none"> <li>- 4 x connecteurs SATA2, prennent en charge un taux de transfert de données pouvant aller jusqu'à 3.0Go/s, supporte RAID (RAID 0, RAID 1, RAID 5, RAID 10 et Intel Rapid Storage3.0), NCQ, AHCI et « Hot Plug » (Branchement à chaud)</li> <li>- 6 x connecteurs SATA3, prennent en charge un taux de transfert de données pouvant aller jusqu'à 6.0Go/s</li> <li>- 1 x en-tête du module infrarouge</li> <li>- 1 x barrette pour module à infrarouges grand public</li> </ul>

	<ul style="list-style-type: none"> <li>- 1 x en-tête de port COM</li> <li>- 1 x connecteur HDMI_SPDIF</li> <li>- 1 x connecteur IEEE 1394</li> <li>- 1 x connecteur de LED d'alimentation</li> <li>- Connecteur pour ventilateur de CPU/Châssis/pouvoir Ventilateur</li> <li>- br. 24 connecteur d'alimentation ATX</li> <li>- br. 8 connecteur d'alimentation 12V ATX</li> <li>- Connecteur d'alimentation SLI/XFIRE</li> <li>- Connecteur audio panneau avant</li> <li>- 3 x en-tête USB 2.0 (prendre en charge 6 ports USB 2.0 supplémentaires)</li> <li>- 2 x en-tête USB 3.0 (prendre en charge 4 ports USB 3.0 supplémentaires)</li> <li>- 1 x Dr. Debug (LED de débogage à 7 segments)</li> </ul>
<b>Interrupteur rapide</b>	<ul style="list-style-type: none"> <li>- 1 x interrupteur d'effacement du CMOS avec LED</li> <li>- 1 x interrupteur d'alimentation avec LED</li> <li>- 1 x interrupteur de réinitialisation avec LED</li> </ul>
<b>BIOS</b>	<ul style="list-style-type: none"> <li>- 64Mb AMI UEFI Legal BIOS avec support GUI</li> <li>- Support du "Plug and Play"</li> <li>- Compatible pour événements de réveil ACPI 1.1</li> <li>- Gestion jumperless</li> <li>- Support SMBIOS 2.3.1</li> <li>- CPU, VCCSA, DRAM, VTT, CPU PLL, PCH1.1V, PCH1.5V Tension Multi-ajustement</li> </ul>
<b>CD d'assistance</b>	<ul style="list-style-type: none"> <li>- Pilotes, utilitaires, logiciel anti-virus (version d'évaluation), CyberLink MediaEspresso 6.5 Trial, Suite logicielle ASRock (Suite multimédia ASRock MAGIX - OEM)</li> </ul>
<b>Caractéristique unique</b>	<ul style="list-style-type: none"> <li>- F-Stream (voir <b>ATTENTION 6</b>)</li> <li>- ASRock l'Instant Boot</li> <li>- ASRock Instant Flash (voir <b>ATTENTION 7</b>)</li> <li>- Chargeur ASRock APP (voir <b>ATTENTION 8</b>)</li> <li>- ASRock SmartView (voir <b>ATTENTION 9</b>)</li> <li>- ASRock XFast USB (voir <b>ATTENTION 10</b>)</li> <li>- ASRock XFast LAN (voir <b>ATTENTION 11</b>)</li> <li>- Chargeur XFast ASRock (voir <b>ATTENTION 12</b>)</li> <li>- ASRock XFast RAM (voir <b>ATTENTION 13</b>)</li> <li>- ASRock Crashless BIOS (voir <b>ATTENTION 14</b>)</li> <li>- L'accélérateur hybride: <ul style="list-style-type: none"> <li>- Contrôle direct de la fréquence CPU (voir <b>ATTENTION 15</b>)</li> </ul> </li> </ul>

	<ul style="list-style-type: none"> <li>- ASRock U-COP (voir <b>ATTENTION 16</b>)</li> <li>- Garde d'échec au démarrage (B.F.G.)</li> <li>- DEL veilleuse</li> </ul>
<b>Surveillance système</b>	<ul style="list-style-type: none"> <li>- Détection de la température de l'UC</li> <li>- Mesure de température de la carte mère</li> <li>- Tachéomètre ventilateur processeur/châssis/pouvoir ventilateur</li> <li>- Ventilateur silencieux pour unité centrale/châssis (permet le réglage automatique de la vitesse du ventilateur pour châssis, selon la température de l'unité centrale)</li> <li>- Commande de ventilateur CPU/Châssis à plusieurs vitesses</li> <li>- Monitoring de la tension: +12V, +5V, +3.3V, Vcore</li> </ul>
<b>OS</b>	<ul style="list-style-type: none"> <li>- Microsoft® Windows® 7 / 7 64-bit / Vista™ / Vista™ 64-bit / XP / XP 64-bit (voir <b>ATTENTION 17</b>)</li> </ul>
<b>Certifications</b>	<ul style="list-style-type: none"> <li>- FCC, CE, WHQL</li> <li>- Prêt pour ErP/EuP (alimentation Prêt pour ErP/EuP requise) (voir <b>ATTENTION 18</b>)</li> </ul>

\* Pour de plus amples informations sur les produits, s'il vous plaît visitez notre site web: <http://www.asrock.com>

#### **ATTENTION**

Il est important que vous réalisiez qu'il y a un certain risque à effectuer l'overclocking, y compris ajuster les réglages du BIOS, appliquer la technologie Untied Overclocking, ou utiliser des outils de tiers pour l'overclocking. L'overclocking peut affecter la stabilité de votre système, ou même causer des dommages aux composants et dispositifs de votre système. Si vous le faites, c'est à vos frais et vos propres risques. Nous ne sommes pas responsables des dommages possibles causés par l'overclocking.

## **ATTENTION!**

1. En ce qui concerne le paramétrage "Hyper-Threading Technology", veuillez consulter la page 67 du manuel de l'utilisateur sur le CD technique.
2. Cette carte mère supporte la technologie de mémoire quadri-canal DDR3. Avant d'intégrer la technologie de mémoire quadri-canal DDR3, assurez-vous de bien lire le guide d'installation des modules mémoire en page 18 pour réaliser une installation correcte.
3. Du fait des limites du système d'exploitation, la taille mémoire réelle réservée au système pourra être inférieure à 4 Go sous Windows® 7 / Vista™ / XP. Avec Windows® OS avec CPU 64 bits, il n'y a pas ce genre

de limitation. Vous pouvez utiliser ASRock XFast RAM pour accéder à la mémoire que Windows® ne peut pas utiliser.

4. Actuellement, le processeur Intel® Socket 2011 Sandy Bridge-E ne prend pas en charge le standard PCIE 3.0, mais cette carte-mère est d'ores et déjà prête à accueillir les équipements PCIE 3.0. Tout dépend de l'activation du PCIE 3.0 par les processeurs Intel. Veuillez consulter le site Internet de Intel pour plus d'informations sur les futures mises à jour et disponibilités des processeurs.
5. Pour l'entrée microphone, cette carte mère supporte les deux modes stéréo et mono. Pour la sortie audio, cette carte mère supporte les modes 2-canaux, 4-canaux, 6-canaux et 8-canaux. Veuillez vous référer au tableau en page 5 pour effectuer la bonne connexion.
6. F-Stream est un utilitaire tout-en-un qui permet de régler précisément différentes fonctions du système, via une interface facile à utiliser, incluant Moniteur de périphériques, Contrôle du ventilateur, Overclocking, OC DNA et IES. Dans Moniteur de périphériques, il affiche les valeurs principales de votre système. Dans Contrôle du ventilateur, il affiche la vitesse du ventilateur et la température, que vous pouvez ajuster. Dans Overclocking, vous pouvez overclocker la fréquence du CPU pour améliorer les performances du système. Dans OC DNA, vous pouvez enregistrer vos réglages OC dans un profil et les partager avec vos amis. Vos amis pourront alors installer le profil OC sur leur système pour utiliser les mêmes réglages OC. Dans IES (Intelligent Energy Saver – Fonction intelligente d'économie d'énergie), le contrôleur de la tension peut réduire le nombre de phases de sortie pour améliorer le fonctionnement lorsque les cores du CPU ne sont pas utilisées, sans diminuer les performances de l'ordinateur.
7. O ASRock Instant Flash é um utilitário de flash do BIOS incorporado na memória Flash ROM. Esta prática ferramenta de atualização do BIOS permite-lhe actualizar o BIOS do sistema sem necessitar de entrar nos sistemas operativos, como o MS-DOS ou o Windows®. Com este utilitário, poderá premir a tecla <F6> durante o teste de arranque POST ou premir a tecla <F2> para exibir o menu de configuração do BIOS para aceder ao ASRock Instant Flash. Execute esta ferramenta para guardar o novo ficheiro de BIOS numa unidade flash USB, numa disquete ou num disco rígido, em seguida, poderá actualizar o BIOS com apenas alguns cliques sem ter de utilizar outra disquete ou outro complicado utilitário de flash. Note que a unidade flash USB ou a unidade de disco rígido devem utilizar o sistema de ficheiros FAT32/16/12.
8. Si vous désirez un moyen plus rapide et moins contraignant de recharger vos appareils Apple tels que iPhone/iPad/iPod Touch, ASRock a préparé pour vous la solution idéale - le chargeur ASRock APP. Il suffit d'installer le pilote du chargeur APP, et vous pourrez recharger rapidement votre iPhone à partir de votre ordinateur, jusqu'à 40% plus vite qu'avant. Le chargeur ASRock APP vous permet de charger rapidement et simultanément plusieurs appareils Apple, et le chargement continu est même pris

---

en charge lorsque le PC passe en mode Veille (S1), Suspension à la RAM (S3), hibernation (S4) ou hors tension (S5). Lorsque le pilote du chargeur APP est installé, vous découvrez un mode de mise en charge tout à fait inédit.

Site web ASRock : <http://www.asrock.com/Feature/AppCharger/index.asp>

9. SmartView, une nouvelle fonction du navigateur Internet, est une page de démarrage intelligente de IE, comportant à la fois vos sites Internet les plus visités, votre historique, vos amis Facebook et l'actualité en temps réel, le tout sur une vue optimisée pour une expérience de l'Internet encore plus personnelle. Les cartes mères ASRock sont équipées en exclusivité de l'utilitaire SmartView, ce qui vous permet de garder le contact avec vos amis itinérants. Pour utiliser la fonction SmartView, veuillez vous assurer que votre version de système d'exploitation est Windows® 7 / 7 64 bits / Vista™ / Vista™ 64 bits, et que vous utilisez le navigateur IE8.  
Site Internet ASRock : <http://www.asrock.com/Feature/SmartView/index.asp>
10. ASRock XFast USB permet d'améliorer les performances de votre périphérique de stockage USB. Les performances réelles dépendent des propriétés du périphérique.
11. ASRock XFast LAN fournit un accès Internet plus rapide, avec les avantages suivants. Priorisation d'application LAN : Vous pouvez configurer votre priorité d'application idéalement et/ou ajouter des nouveaux programmes. Latence plus basse dans les jeux : Après avoir réglé la priorité de jeux en ligne plus haute, cela peut réduire la latence dans les jeux. Forme du trafic : Vous pouvez regarder des vidéos HD YouTube et télécharger simultanément des fichiers. Analyse en temps réel de vos données : Avec la fenêtre d'état, vous pouvez facilement reconnaître les flux de données que vous êtes en train de transférer.
12. Le chargeur XFast ASRock apporte la technologie la meilleure et la plus rapide pour recharger vos appareils mobiles via PC. Avec le superbe port USB du chargeur XFast, vous êtes assuré de pouvoir avoir à tout moment les charges les plus rapides. En plus des appareils Apple, il est aussi capable de recharger les appareils intelligents à la norme BC 1.1. Pour plus de détails, veuillez vous reporter à la page 35.
13. ASRock XFast RAM est une nouvelle fonction intégrée à l'utilitaire F-Stream. Il utilise à sa pleine capacité l'espace mémoire que les processeurs du système d'exploitation Windows OS 32-bit ne peuvent pas utiliser. ASRock XFast RAM diminue le temps de chargement des sites Internet précédemment visités, rendant la navigation sur le web plus rapide que jamais. Il rend également l'utilisation de Adobe Photoshop 5 fois plus rapide. Un autre avantage indéniable de ASRock XFast RAM est qu'il réduit la fréquence d'accès à vos SSD ou HDD afin d'accroître leur durée de vie utile.
14. ASRock Crashless BIOS permet aux utilisateurs de mettre à jour leur BIOS sans qu'ils aient à craindre un plantage ou une défaillance. Si

---

l'alimentation venait à être coupée durant la mise à jour du BIOS, AS-Rock Crashless BIOS terminera automatiquement la mise à jour du BIOS une fois le courant rétabli. Veuillez noter que les fichiers BIOS doivent être placés dans le répertoire racine de votre disque USB. Seuls les ports USB2.0 sont compatibles avec cette fonction.

15. Même si cette carte mère offre un contrôle sans souci, il n'est pas recommandé d'y appliquer un over clocking. Des fréquences de bus CPU autres que celles recommandées risquent de rendre le système instable ou d'endommager le CPU et la carte mère.
16. Lorsqu'une surchauffe du CPU est détectée, le système s'arrête automatiquement. Avant de redémarrer le système, veuillez vérifier que le ventilateur d'UC sur la carte mère fonctionne correctement et débranchez le cordon d'alimentation, puis rebranchez-le. Pour améliorer la dissipation de la chaleur, n'oubliez pas de mettre de la pâte thermique entre le CPU le dissipateur lors de l'installation du PC.
17. Intel Rapid Storage Technology enterprise 3.0 et ASRock XFast RAM n'est pas pris en charge par Microsoft® Windows® XP / XP 64-bit.
18. EuP, qui signifie Energy Using Product (Produit Utilisant de l'Energie), est une disposition établie par l'Union Européenne pour définir la consommation de courant pour le système entier. Conformément à la norme EuP, le courant CA total du système entier doit être inférieur à 1 W en mode d'arrêt. Pour être conforme à la norme EuP, une carte mère EuP et une alimentation EuP sont requises. Selon les suggestions d'Intel, l'alimentation électrique EuP doit correspondre à la norme, qui est que l'efficacité électrique de 5v en mode de veille doit être supérieure à 50% pour 100 mA de consommation de courant. Pour choisir une alimentation électrique conforme à la norme EuP, nous vous recommandons de consulter votre fournisseur de courant pour plus de détails.

### 1.3 Réglage des cavaliers

L'illustration explique le réglage des cavaliers. Quand un capuchon est placé sur les broches, le cavalier est « FERME ». Si aucun capuchon ne relie les broches, le cavalier est « OUVERT ». L'illustration montre un cavalier à 3 broches dont les broches 1 et 2 sont « FERMEES » quand le capuchon est placé sur ces 2 broches.



#### Le cavalier

#### Description

Effacer la CMOS

(CLR CMOS1)

(voir p.4 fig. 25)



Paramètres  
par défaut



Effacer la  
CMOS

Remarque : CLR CMOS1 vous permet d'effacer les données du CMOS. Pour effacer et réinitialiser les paramètres du système à la configuration originale, veuillez éteindre l'ordinateur et débrancher le cordon d'alimentation de la prise de courant. Après 15 secondes, utilisez un couvercle de jumper pour court-circuiter les broches pin2 et pin3 de CLR CMOS1 pendant 5 secondes. Veuillez cependant ne pas effacer le CMOS immédiatement après avoir mis à jour le BIOS. Si vous avez besoin d'effacer le CMOS après avoir mis à jour le BIOS, vous devez allumer en premier le système, puis l'éteindre avant de continuer avec l'opération d'effacement du CMOS. Veuillez noter que le mot de passe, la date, l'heure, le profil par défaut de l'utilisateur, 1394 GUID et l'adresse MAC seront effacés seulement si la batterie du CMOS est enlevée.



Le commutateur Effacer CMOS présente la même fonction que le cavalier Effacer CMOS.

## 1.4 En-têtes et Connecteurs sur Carte



Les en-têtes et connecteurs sur carte NE SONT PAS des cavaliers. NE PAS placer les capuchons de cavalier sur ces en-têtes et connecteurs. Le fait de placer les capuchons de cavalier sur les en-têtes et connecteurs causera à la carte mère des dommages irréversibles!

### Connecteurs Série ATA2

(SATA2\_0\_1: voir p.4 No. 13)

(SATA2\_2\_3: voir p.4 No. 12)

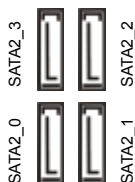

Ces quatre connecteurs Série ATA2 (SATA2) prennent en charge les câbles SATA pour les périphériques de stockage internes. L'interface SATA2 actuelle permet des taux transferts de données pouvant aller jusqu'à 3,0 Gb/s.

### Connecteurs Série ATA3

(SATA3\_0\_1: voir p.2 No. 14)

(SATA3\_M0\_M1: voir p.4 No. 15)

(SATA3\_M2\_M3: voir p.4 No. 16)

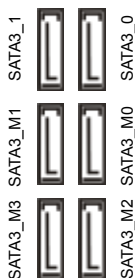

Ces six connecteurs Série ATA3 (SATA3) prennent en charge les câbles SATA pour les périphériques de stockage internes. L'interface SATA3 actuelle permet des taux transferts de données pouvant aller jusqu'à 6,0 Gb/s.

### Câble de données Série ATA (SATA)

(en option)



Toute cote du câble de data SATA peut être connectée au disque dur SATA / SATA2 / SATA3 ou au connecteur SATA2 / SATA3 sur la carte mère.

### Cordon d'alimentation Série ATA (SATA)

(en option)



Veuillez connecter l'extrémité noire du cordon d'alimentation SATA sur le connecteur d'alimentation sur chaque unité. Connectez ensuite l'extrémité blanche du cordon d'alimentation SATA sur le connecteur d'alimentation de l'unité d'alimentation électrique.



## En-tête USB 2.0

(USB\_6\_7 br.9)

(voir p.4 No. 29)

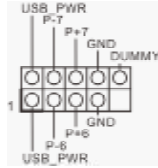

(USB\_8\_9 br.9)

(voir p.4 No. 28)

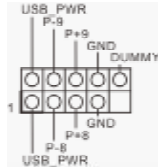

(USB\_10\_11 br.9)

(voir p.4 No. 27)

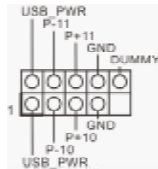

A côté des six ports USB 2.0 par défaut sur le panneau E/S, il y a trois embases USB 2.0 sur cette carte mère. Chaque embase USB 2.0 peut prendre en charge 2 ports USB 2.0.

## En-tête USB 3.0

(USB3\_5\_6 br.19)

(voir p.4 No. 8)

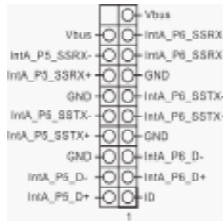

(USB3\_7\_8 br.19)

(voir p.4 No. 9)

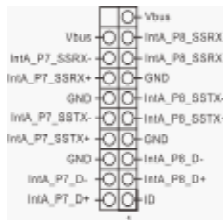

En plus des quatre ports USB 3.0 par défaut sur le panneau E/S, il y a deux barrette USB 3.0 sur la carte mère. Chaque embase USB 3.0 peut prendre en charge 2 ports USB 3.0.

## En-tête du module infrarouge

(IR1 br.5)

(voir p.4 No. 37)

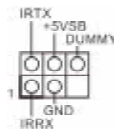

Cet en-tête supporte un module infrarouge optionnel de transfert et de réception sans fil.

### Barrette pour module à infrarouges grand public

(CIR1 br.4)

(voir p.4 No. 30)



Cette barrette peut être utilisée pour connecter des modules à infrarouges grand public, comme chaînes hi-fi, décodeurs, etc.

### Connecteur audio panneau

(HD\_AUDIO1 br. 9)

(voir p.4 No. 35)

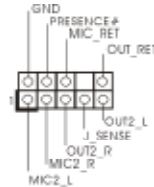

C'est une interface pour un câble avant audio en façade qui permet le branchement et le contrôle commodes de périphériques audio.



1. L'audio à haute définition (HDA) prend en charge la détection de fiche, mais le fil de panneau sur le châssis doit prendre en charge le HDA pour fonctionner correctement. Veuillez suivre les instructions dans notre manuel et le manuel de châssis afin d'installer votre système.

2. Si vous utilisez le panneau audio AC'97, installez-le sur l'adaptateur audio du panneau avant conformément à la procédure ci-dessous:

- A. Connectez Mic\_IN (MIC) à MIC2\_L.
- B. Connectez Audio\_R (RIN) à OUT2\_R et Audio\_L (LIN) à OUT2\_L.
- C. Connectez Ground (GND) à Ground (GND).
- D. MIC\_RET et OUT\_RET sont réservés au panneau audio HD. Vous n'avez pas besoin de les connecter pour le panneau audio AC'97.
- E. Pour activer le micro avant.

Pour les systèmes d'exploitation Windows® XP / XP 64 bits :  
Sélectionnez "Mixer". Sélectionnez "Recorder" (Enregistreur). Puis cliquez sur "FrontMic" (Micro avant).

Pour les systèmes d'exploitation Windows® 7 / 7 64 bits / Vista™ / Vista™ 64 bits :

Allez sur l'onglet "FrontMic" (Micro avant) sur le Panneau de contrôle Realtek. Ajustez "Recording Volume" (Volume d'enregistrement).

### En-tête du panneau système

(PANEL1 br.9)

(voir p.4 No. 22)

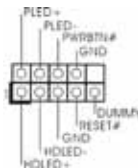

Cet en-tête permet d'utiliser plusieurs fonctions du panneau système frontal.



Connectez l'interrupteur d'alimentation, l'interrupteur de réinitialisation et l'indicateur d'état du système du châssis sur cette barrette en respectant l'affectation des broches décrite ci-dessous. Faites attention aux broches positives et négatives avant de connecter les câbles.

**PWRBTN (Interrupteur d'alimentation):**

Connectez ici le connecteur d'alimentation sur le panneau avant du châssis. Vous pouvez configurer la façon de mettre votre système hors tension avec l'interrupteur d'alimentation.

**RESET (Interrupteur de réinitialisation):**

Connectez ici le connecteur de réinitialisation sur le panneau avant du châssis. Appuyez sur l'interrupteur de réinitialisation pour redémarrer l'ordinateur s'il se bloque ou s'il n'arrive pas à redémarrer normalement.

**PLED (DEL alimentation système):**

Connectez ici l'indicateur d'état de l'alimentation sur le panneau avant du châssis. Ce voyant DEL est allumé lorsque le système est en marche. Le voyant DEL clignote lorsque le système est en mode veille S1. Le voyant DEL est éteint lorsque le système est en mode veille S3/S4 ou lorsqu'il est éteint (S5).

**HDLED (DEL activité du disque dur):**

Connectez ici le voyant DEL d'activité du disque dur sur le panneau avant du châssis. Ce voyant DEL est allumé lorsque le disque dur est en train de lire ou d'écrire des données.

Le design du panneau avant peut varier en fonction du châssis. Un module de panneau avant consiste principalement en : interrupteur d'alimentation, interrupteur de réinitialisation, voyant DEL d'alimentation, voyant DEL d'activité du disque dur, haut-parleur, etc. Lorsque vous connectez le panneau avant de votre châssis sur cette barrette, vérifiez bien à faire correspondre les fils et les broches.

**En-tête du haut-parleur de châssis**

(SPEAKER1 br. 4)  
(voir p.4 No. 21)

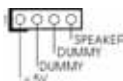

Veuillez connecter le haut-parleur de châssis sur cet en-tête.

**LED di accensione**

(3-pin PLED1)  
(vedi p.4 No. 23)



Collegare il LED di accensione chassi per indicare lo stato di alimentazione del sistema. Il LED è acceso quando il sistema è in funzione. Il LED continua a lampeggiare in stato S1. Il LED è spento in stato S3/S4 o S5 (spegnimento).

### Connecteur pour châssis et ventilateur

(CHA\_FAN1 br.4)

(voir p.4 No. 11)

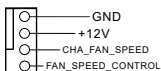

(CHA\_FAN2 br. 3)

(voir p.4 No. 20)

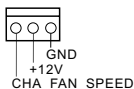

(CHA\_FAN3 br. 3)

(voir p.4 No. 17)

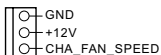

(PWR\_FAN1 br. 3)

(voir p.4 No. 44)

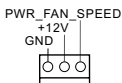

Branchez les câbles du ventilateur aux connecteurs pour ventilateur et faites correspondre le fil noir à la broche de terre. CHA\_FAN1, CHA\_FAN2 et CHA\_FAN3 prennent en charge la fonction contrôle du ventilateur.

### Connecteur du ventilateur de l'UC

(CPU\_FAN1 br. 4)

(voir p.4 No. 5)

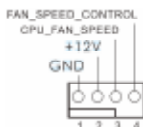

Veillez connecter le câble de ventilateur d'UC sur ce connecteur et brancher le fil noir sur la broche de terre.



Bien que cette carte mère offre un support de (Ventilateur silencieux ventilateur de CPU à 4 broches , le ventilateur de CPU à 3 broches peut bien fonctionner même sans la fonction de commande de vitesse du ventilateur. Si vous prévoyez de connecter le ventilateur de CPU à 3 broches au connecteur du ventilateur de CPU sur cette carte mère, veuillez le connecter aux broches 1-3.

#### Installation de ventilateur à 3 broches

Broches 1-3 connectées

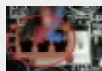

(CPU\_FAN2 br. 3)

(voir p.4 No. 6)

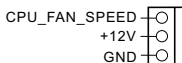

### En-tête d'alimentation ATX

(ATXPWR1 br. 24)

(voir p.4 No. 7)

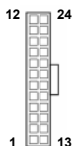

Veillez connecter l'unité d'alimentation ATX sur cet en-tête.



Bien que cette carte mère fournisse un connecteur de courant ATX 24 broches, elle peut encore fonctionner si vous adoptez une alimentation traditionnelle ATX 20 broches. Pour utiliser une alimentation ATX 20 broches, branchez à l'alimentation électrique ainsi qu'aux broches 1 et 13.

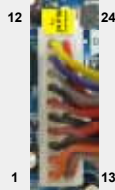

20-Installation de l'alimentation électrique ATX

### Connecteur ATX 12V

(ATX12V1 br.8)

(voir p.4 No. 3)

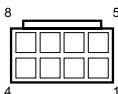

Veillez connecter une unité d'alimentation électrique ATX 12V sur ce connecteur.



Bien que cette carte mère possède 8 broches connecteur d'alimentation ATX 12V, il peut toujours travailler si vous adoptez une approche traditionnelle à 4 broches ATX 12V alimentation. Pour utiliser l'alimentation des 4 broches ATX, branchez votre alimentation avec la broche 1 et la broche 5.

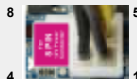

4-Installation d'alimentation à 4 broches ATX 12V

### Connecteur d'alimentation SLI/XFIRE

(SLI/XFIRE\_POWER1 br. 4)

(voir p.4 No. 31)



SLI/XFIRE\_POWER1

Il n'est pas nécessaire d'utiliser ce connecteur, mais veuillez le brancher avec un connecteur d'alimentation pour disques durs quand deux cartes graphiques sont branchées sur cette carte mère en même temps.

### Header de IEEE 1394

(FRONT\_1394 br. 9)

(voir p.4 No. 34)

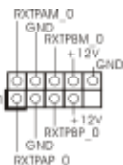

Sauf un port de default IEEE 1394 sur le panel I/O, il y a un header de IEEE1394 (FRONT\_1394) sur cette carte mere. Le header de IEEE 1394 peut supporter un port de IEEE 1394.

---

### En-tête de port COM

(COM1 br.9)

(voir p.4 No. 32)

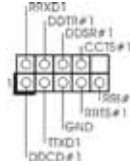

Cette en-tête de port COM est utilisée pour prendre en charge un module de port COM.

---

### Connecteur HDMI\_SPDIF

(HDMI\_SPDIF1 2-pin)

(voir p.4 No. 33)



Connecteur HDMI\_SPDIF, fournissant une sortie audio SPDIF vers la carte VGA HDMI, et permettant au système de se connecter au un téléviseur numérique HDMI /un projecteur / un périphérique LCD. Veuillez brancher le connecteur HDMI\_SPDIF de la carte VGA HDMI sur ce connecteur.

---

## Le Guide d'installation du panneau USB 3.0 frontal

**Étape 1** Préparez le panneau USB 3.0 frontal fourni, quatre vis HDD et six vis de châssis.



**Étape 2** Vissez le HDD/SSD 2,5" sur le panneau USB 3.0. frontal avec les quatre vis HDD.



**Étape 3** Installez le panneau USB 3.0 frontal dans la baie de disque 2,5" du châssis.



**Étape 4** Vissez le panneau USB 3.0 frontal dans la baie de disque avec les six vis de châssis.



**Étape 5** Branchez le câble USB 3.0 dans le connecteur USB 3.0 (USB3\_5\_6 ou USB3\_7\_8) de la carte mère.



**Étape 6** Le panneau USB 3.0 frontal peut maintenant être utilisé.



## Le Guide d'installation du Support arrière USB 3.0

**Étape 1** Dévissez les deux vis du panneau avant USB 3.0.



**Étape 2** Assemblez le câble USB 3.0 et le support arrière USB 3.0.



**Étape 3** Vissez les deux vis dans le support arrière USB 3.0.



**Étape 4** Placez le support arrière USB 3.0 dans le châssis.



---

## 1.5 Interrupteur rapides

Cette carte mère dispose de trois interrupteurs rapides : un interrupteur d'alimentation, un interrupteur de réinitialisation et un interrupteur d'effacement de CMOS, permettant aux utilisateurs de rapidement allumer/éteindre ou réinitialiser le système, ainsi que d'effacer les valeurs du CMOS.

---

### Interrupteur d'alimentation

(PWRBTN)  
(voir p.4 No. 18)



L'interrupteur d'alimentation est un interrupteur rapide, qui permet à l'utilisateur d'allumer/éteindre rapidement le système.

---

### Interrupteur de réinitialisation

(RSTBTN)  
(voir p.4 No. 19)



L'interrupteur de réinitialisation est un interrupteur rapide, qui permet à l'utilisateur de réinitialiser rapidement le système.

---

### Interrupteur d'effacement de CMOS

(CLRBTN)  
(voir p.5 No. 18)



L'interrupteur d'effacement de CMOS est un interrupteur rapide qui permet à l'utilisateur d'effacer rapidement les valeurs du CMOS.



---

## 2. Informations sur le BIOS

La puce Flash Memory sur la carte mère stocke le Setup du BIOS. Lorsque vous démarrez l'ordinateur, veuillez presser <F2> ou <Del> pendant le POST (Power-On-Self-Test) pour entrer dans le BIOS; sinon, le POST continue ses tests de routine. Si vous désirez entrer dans le BIOS après le POST, veuillez redémarrer le système en pressant <Ctl> + <Alt> + <Suppr>, ou en pressant le bouton de reset sur le boîtier du système. Vous pouvez également redémarrer en éteignant le système et en le rallumant. L'utilitaire d'installation du BIOS est conçu pour être convivial. C'est un programme piloté par menu, qui vous permet de faire défiler par ses divers sous-menus et de choisir parmi les choix prédéterminés. Pour des informations détaillées sur le BIOS, veuillez consulter le Guide de l'utilisateur (fichier PDF) dans le CD technique.

## 3. Informations sur le CD de support

Cette carte mère supporte divers systèmes d'exploitation Microsoft® Windows®: 7 / 7 64 bits / Vista™ / Vista™ 64 bits / XP / XP 64 bits. Le CD technique livré avec cette carte mère contient les pilotes et les utilitaires nécessaires pour améliorer les fonctions de la carte mère. Pour utiliser le CD technique, insérez-le dans le lecteur de CD-ROM. Le Menu principal s'affiche automatiquement si "AUTORUN" est activé dans votre ordinateur. Si le Menu principal n'apparaît pas automatiquement, localisez dans le CD technique le fichier "ASSETUP.EXE" dans le dossier BIN et double-cliquez dessus pour afficher les menus.

---

# 1. Introduzione

Grazie per aver scelto una scheda madre **Fatal1ty X79 Professional Series**, una scheda madre affidabile prodotta secondo i severi criteri di qualità ASRock. Le prestazioni eccellenti e il design robusto si conformano all'impegno di ASRock nella ricerca della qualità e della resistenza.

Questa Guida Rapida all'Installazione contiene l'introduzione alla motherboard e la guida passo-passo all'installazione. Informazioni più dettagliate sulla motherboard si possono trovare nel manuale per l'utente presente nel CD di supporto.



Le specifiche della scheda madre e il software del BIOS possono essere aggiornati, pertanto il contenuto di questo manuale può subire variazioni senza preavviso. Nel caso in cui questo manuale sia modificato, la versione aggiornata sarà disponibile sul sito di ASRock senza altro avviso. Sul sito ASRock si possono anche trovare le più recenti schede VGA e gli elenchi di CPU supportate.

ASRock website <http://www.asrock.com>

Se si necessita dell'assistenza tecnica per questa scheda madre, visitare il nostro sito per informazioni specifiche sul modello che si sta usando.  
[www.asrock.com/support/index.asp](http://www.asrock.com/support/index.asp)

## 1.1 Contenuto della confezione

Scheda madre **Fatal1ty X79 Professional Series**

(ATX Form Factor: 12.0-in x 9.6-in, 30.5 cm x 24.4 cm)

Guida di installazione rapida **Fatal1ty X79 Professional Series**

CD di supporto **Fatal1ty X79 Professional Series**

Sei cavi dati Serial ATA (SATA) (opzionali)

Due cavi di alimentazione HDD Serial ATA (SATA) (opzionali)

Un I/O Shield

Un porta USB 3.0 sul pannello frontale

Quattro HDD viti

Sei telaio viti

Un supporto USB 3.0 posteriore

Due scheda ASRock SLI\_Bridge

Un scheda ASRock SLI\_Bridge\_3S

Un scheda Bridge ASRock 3-Way SLI



### **ASRock vi ricorda...**

Per ottenere migliori prestazioni in Windows® 7 / 7 64-bit / Vista™ / Vista™ 64-bit, si consiglia di impostare l'opzione BIOS in Storage Configuration (Configurazione di archiviazione) sulla modalità AHCI. Per l'impostazione BIOS, fare riferimento a "User Manual" (Manuale dell'utente) nel CD di supporto per dettagli.

## 1.2 Specifiche

<b>Piattaforma</b>	<ul style="list-style-type: none"> <li>- ATX Form Factor: 12.0-in x 9.6-in, 30.5 cm x 24.4 cm</li> <li>- Design Premium Gold Capacitor (condensatori a polimeri conduttivi di altissima qualità 100% made in Japan)</li> </ul>
<b>Processore</b>	<ul style="list-style-type: none"> <li>- Supporta processori della famiglia Intel® Core™ i7 per il Socket LGA 2011</li> <li>- Design Digi Power</li> <li>- Struttura di fase con alimentazione 16 + 2 avanzata</li> <li>- Supporto della tecnologia Intel® Turbo Boost 2.0</li> <li>- Supporto tecnologia Hyper Threading (vedi <b>ATTENZIONE 1</b>)</li> <li>- Supporta la tecnologia overclocking "slegata"</li> </ul>
<b>Chipset</b>	- Intel® X79
<b>Memoria</b>	<ul style="list-style-type: none"> <li>- Tecnologia memoria DDR3 Quad Channel (vedi <b>ATTENZIONE 2</b>)</li> <li>- 4 x slots DDR3 DIMM</li> <li>- Supporto DDR3 2400+(OC)/2133(OC)/1866(OC)/1600/1333/1066/800 non-ECC, memoria senza buffer</li> <li>- Supporta memoria un-buffered ECC DDR3, con processori Intel® Workstation 1S Xeon® E5 serie 16XX/26xx/46xx in socket LGA 2011</li> <li>- Capacità massima della memoria di sistema: 32GB (vedi <b>ATTENZIONE 3</b>)</li> <li>- Supporto di Intel® XMP (Extreme Memory Profile) 1.3/1.2</li> </ul>
<b>Slot di espansione</b>	<ul style="list-style-type: none"> <li>- 4 x Alloggio PCI Express 3.0 x16 (PCIE1/PCIE2/PCIE4/PCIE5 : modalità x16/8/16/0; modalità x16/8/88) (vedi <b>ATTENZIONE 4</b>)</li> <li>- 1 x Alloggio PCI Express 2.0 x1</li> <li>- 2 x Alloggio PCI</li> <li>- Supporto di AMD Quad CrossFireX™, 4-Way CrossFireX™, 3-Way CrossFireX™ e CrossFireX™</li> <li>- Supporto di NVIDIA® Quad SLI™, 4-Way SLI™, 3-Way SLI™ e SLI™</li> </ul>
<b>Audio</b>	<ul style="list-style-type: none"> <li>- 7.1 CH HD Audio con protezioni contenuti (Realtek ALC898 Audio Codec)</li> <li>- Supporto audio Blu-ray Premium</li> <li>- Supporto THX TruStudio™</li> </ul>
<b>LAN</b>	<ul style="list-style-type: none"> <li>- PCIE x1 Gigabit LAN 10/100/1000 Mb/s</li> <li>- Broadcom BCM57781</li> <li>- Supporta Wake-On-LAN</li> <li>- Supporto di Energy Efficient Ethernet 802.3az</li> <li>- Supporta PXE</li> </ul>

<b>Pannello posteriore I/O</b>	I/O Panel <ul style="list-style-type: none"> <li>- 1 x porta PS/2 per tastiera</li> <li>- 1 x porta coassiale SPDIF Out</li> <li>- 1 x Porta ottica SPDIF Out</li> <li>- 5 x porte USB 2.0 già integrate</li> <li>- 1 x porta Fatal1ty per Mouse (USB 2.0)</li> <li>- 2 x Connettori eSATA3</li> <li>- 4 x porte USB 3.0 già integrate</li> <li>- 1 x porte LAN RJ-45 con LED (LED azione/collegamento e LED velocità)</li> <li>- 1 x porte IEEE 1394</li> <li>- 1 x interruttore di pulizia CMOS</li> <li>- Connettore HD Audio: cassa posteriore / cassa centrale / bassi / ingresso linea / cassa frontale / microfono (vedi <b>ATTENZIONE 5</b>)</li> </ul>
<b>SATA3</b>	<ul style="list-style-type: none"> <li>- 2 x Connettori SATA3 6,0Gb/s X79 Intel<sup>®</sup>, supporto RAID (RAID 0, RAID 1, RAID 5, RAID 10 e Intel Rapid Storage3.0) e delle funzioni NCQ, AHCI e “Hot Plug”</li> <li>- 4 x Connettori SATA3 6,0Gb/s Marvell SE9172, supporto RAID (RAID 0 e RAID 1), delle funzioni NCQ, AHCI e “Hot Plug”</li> </ul>
<b>USB 3.0</b>	<ul style="list-style-type: none"> <li>- 4 x porte USB 3.0 posteriori amministrare dal controller TI<sup>®</sup>, supporto di USB 1.0/2.0/3.0 fino a 5Gb/s</li> <li>- 2 x header USB 3.0 frontale (supporta 4 porte USB 3.0) amministrato dal controller TI<sup>®</sup>, supporto di USB 1.0/2.0/3.0 fino a 5Gb/s</li> </ul>
<b>Connettori</b>	<ul style="list-style-type: none"> <li>- 4 x connettori SATA2 3.0Go/s, supporta RAID (RAID 0, RAID 1, RAID 5, RAID 10 e Intel Rapid Storage3.0) e delle funzioni NCQ, AHCI e “Hot Plug”</li> <li>- 6 x connettori SATA3 6.0Go/s</li> <li>- 1 x Collettore modulo infrarossi</li> <li>- 1 x Collettore modulo infrarosso consumer</li> <li>- 1 x collettore porta COM</li> <li>- 1 x connettore HDMI_SPDIF</li> <li>- 1 x collettore IEEE 1394</li> <li>- 1 x LED di accensione</li> <li>- Connettore CPU/Chassis/Alimentazione ventola</li> <li>- 24-pin collettore alimentazione ATX</li> <li>- 8-pin connettore ATX 12V</li> <li>- Collettore alimentazione SLI/XFIRE</li> <li>- Connettore audio sul pannello frontale</li> <li>- 3 x Collettore USB 2.0 (supporta 6 porte USB 2.0)</li> </ul>

	<ul style="list-style-type: none"> <li>- 2 x Collettore USB 3.0 (supporta 4 porte USB 3.0)</li> <li>- 1 x Dr. Debug (LED debug con 7 segmenti)</li> </ul>
<b>Interruttore rapido</b>	<ul style="list-style-type: none"> <li>- 1 x interruttore pulizia CMOS con LED</li> <li>- 1 x interruttore di alimentazione con LED</li> <li>- 1 x interruttore di reset con LED</li> </ul>
<b>BIOS</b>	<ul style="list-style-type: none"> <li>- 64Mb AMI UEFI Legal BIOS con interfaccia di supporto</li> <li>- Supporta "Plug and Play"</li> <li>- Compatibile con ACPI 1.1 wake up events</li> <li>- Supporta jumperfree</li> <li>- Supporta SMBIOS 2.3.1</li> <li>- Regolazione multi-voltaggio CPU, VCCSA, DRAM, VTT, CPU PLL, PCH1.1V, PCH1.5V</li> </ul>
<b>CD di supporto</b>	<ul style="list-style-type: none"> <li>- Driver, Utilità, Software AntiVirus (versione di prova), CyberLink MediaEspresso 6.5 Trial, Suite software ASRock (Suite multimediale ASRock MAGIX - OEM)</li> </ul>
<b>Caratteristica speciale</b>	<ul style="list-style-type: none"> <li>- F-Stream (vedi <b>ATTENZIONE 6</b>)</li> <li>- ASRock Instant Boot</li> <li>- ASRock Instant Flash (vedi <b>ATTENZIONE 7</b>)</li> <li>- Caricatore ASRock APP Charger (vedi <b>ATTENZIONE 8</b>)</li> <li>- ASRock SmartView (vedi <b>ATTENZIONE 9</b>)</li> <li>- ASRock XFast USB (vedi <b>ATTENZIONE 10</b>)</li> <li>- ASRock XFast LAN (vedi <b>ATTENZIONE 11</b>)</li> <li>- ASRock XFast Charger (vedi <b>ATTENZIONE 12</b>)</li> <li>- ASRock XFast RAM (vedi <b>ATTENZIONE 13</b>)</li> <li>- ASRock Crashless BIOS (vedi <b>ATTENZIONE 14</b>)</li> <li>- Booster ibrido: <ul style="list-style-type: none"> <li>- Stepless control per frequenza del processore (vedi <b>ATTENZIONE 15</b>)</li> <li>- ASRock U-COP (vedi <b>ATTENZIONE 16</b>)</li> <li>- Boot Failure Guard (B.F.G.)</li> </ul> </li> <li>- LED notturno</li> </ul>
<b>Monitoraggio Hardware</b>	<ul style="list-style-type: none"> <li>- Sensore per la temperatura del processore</li> <li>- Sensore temperatura scheda madre</li> <li>- Indicatore di velocità per la ventola del CPU/Chassis/potenza Alimentazione</li> <li>- Ventola CPU/Chassis silenziosa (permette la regolazione automatica della ventola dello chassis in base alla temperatura della CPU)</li> <li>- Ventola CPU/chassis/SB con controllo di varie velocità</li> <li>- Voltaggio: +12V, +5V, +3.3V, Vcore</li> </ul>
<b>Compatibilità</b>	<ul style="list-style-type: none"> <li>- Microsoft® Windows® 7 / 7 64 bit / Vista™ / Vista™ 64 bit / XP /</li> </ul>

<b>SO</b>	XP 64 bit (vedi <b>ATTENZIONE 17</b> )
<b>Certificazioni</b>	- FCC, CE, WHQL - Predisposto ErP/EuP (è necessaria l'alimentazione predisposta per il sistema ErP/EuP) (vedi <b>ATTENZIONE 18</b> )

\* Per ulteriori informazioni, prego visitare il nostro sito internet: <http://www.asrock.com>

#### **AVVISO**

Si prega di prendere atto che la procedura di overclocking implica dei rischi, come anche la regolazione delle impostazioni del BIOS, l'applicazione della tecnologia Untied Overclocking Technology, oppure l'uso di strumenti di overclocking forniti da terzi. L'overclocking può influenzare la stabilità del sistema, ed anche provocare danni ai componenti ed alle periferiche del sistema. La procedura è eseguita a proprio rischio ed a proprie spese. Noi non possiamo essere ritenuti responsabili per possibili danni provocati dall'overclocking.

## **ATTENZIONE!**

1. Per il settaggio della "Tecnologia Hyper-Threading", per favore controllare pagina 67 del Manuale dell'utente all'interno del CD di supporto.
2. Questa scheda madre supporta la tecnologia memoria DDR3 Quad Channel. Prima di implementare la tecnologia memoria DDR3 Quad Channel, assicurarsi di leggere la guida all'installazione dei moduli di memoria, a pagina 18, per seguire un'installazione appropriata.
3. A causa delle limitazioni del sistema operativo, le dimensioni effettive della memoria possono essere inferiori a 4GB per l'accantonamento riservato all'uso del sistema sotto Windows® 7 / Vista™ / XP. Per Windows® OS con CPU 64-bit, non c'è tale limitazione. Si può usare ASRock XFast RAM per fare uso della memoria che Windows® non può utilizzare.
4. Attualmente il processore Intel® Socket 2011 Sandy Bridge-E non supporta PCIe 3.0, tuttavia questa scheda madre è già pronta per l'hardware PCIe 3.0. Dipende alla CPU Intel abilitare il PCIe 3.0. Controllare il sito Intel per informazioni sui futuri aggiornamenti e nuove CPU.
5. Questa scheda madre supporta l'ingresso stereo e mono per il microfono. Questa scheda madre supporta le modalità 2 canali, 4 canali, 6 canali e 8 canali per l'uscita audio. Controllare la tavola a pagina 5 per eseguire il collegamento appropriato.
6. L'utilità F-Stream è uno strumento tutto in uno per regolare varie funzioni del sistema in un'interfaccia facile da usare che include monitoraggio hardware, controllo ventola, overclocking, OC DNA ed IES. Hardware Monitor (Monitoraggio hardware) mostra le letture principali del sistema. Fan Control (Controllo ventola) mostra la velocità e la temperatura che possono essere regolate. Overclocking permette di eseguire l'overclocking della frequenza della CPU per ottenere le prestazioni ottimali del

---

sistema. OC DNA permette di salvare le impostazioni OC come un profilo da condividere con gli amici! Gli amici possono scaricare il profilo OC sul loro sistema operativo per ottenere le stesse impostazioni OC. Il regolatore di tensione di IES (Intelligent Energy Saver) può ridurre il numero di fasi d'uscita per migliorare l'efficienza quando i core CPU sono inattivi senza sacrificare le prestazioni di computazione.

7. ASRock Instant Flash è una utilità Flash BIOS integrata nella Flash ROM. Questo comodo strumento d'aggiornamento del BIOS permette di aggiornare il sistema BIOS senza accedere a sistemi operativi come MS-DOS or Windows®. Con questa utilità, si può premere il tasto <F6> durante il POST, oppure il tasto <F2> nel menu BIOS per accedere ad ASRock Instant Flash. Avviare questo strumento e salvare il nuovo file BIOS nell'unità Flash USB, dischetto (disco floppy) o disco rigido; poi si può aggiornare il BIOS con pochi clic, senza preparare altri dischetti (dischi floppy) o altre complicate utilità Flash. Si prega di notare che l'unità Flash USB o il disco rigido devono usare il File System FAT32/16/12.
8. Se vuoi un modo rapido e indipendente per caricare i dispositivi Apple, come iPhone/iPad/iPod Touch, ASRock ha preparato una soluzione meravigliosa: ASRock APP Charger. Basta installare il driver APP Charger per caricare l'iPhone più rapidamente rispetto al computer, con una velocità maggiore del 40%. ASRock APP Charger permette di caricare simultaneamente molti dispositivi Apple in modo rapido e supporta anche il caricamento continuato quando il PC accede alla modalità di Standby (S1), Sospensione su RAM (S3), Ibernazione (S4) o Spegnimento (S5). Una volta installato il driver APP Charger si otterranno prodigi e comodità mai avuti prima.  
Sito ASRock: <http://www.asrock.com/Feature/AppCharger/index.asp>
9. SmartView, una nuova funzione di browser Internet, è la pagina iniziale intelligente di IE che unisce i siti web più visitati, la cronologia, gli amici di Facebook e il newsfeed in tempo reale in una visione migliorata per una esperienza Internet più personale. Le schede madri ASRock sono dotate in modo esclusivo dell'utility SmartView, che consente di mantenersi sempre in contatto con gli amici. Per utilizzare la funzione SmartView, assicurarsi che la versione del sistema operativo sia Windows® 7 / 7 64 bit / Vista™ / Vista™ 64 bit e che la versione del browser sia IE8. Sito web ASRock: <http://www.asrock.com/Feature/SmartView/index.asp>
10. ASRock XFast USB può accelerare le prestazioni del dispositivo d'archiviazione USB. Le prestazioni dipendono dalle proprietà del dispositivo.
11. ASRock XFast LAN offre un accesso a Internet più veloce, che comprende i seguenti benefici. Priorità alle applicazioni LAN: è possibile configurare la priorità assegnata alle applicazioni in modo ideale e/o aggiungere nuovi programmi. Minore latenza nei giochi: dopo avere impostato la priorità dei giochi su un livello più alto, la latenza dei giochi può essere minore. Configurazione del traffico: è possibile seguire video HD su Youtube e scaricare file contemporaneamente. Analisi in tempo reale dei dati: grazie alla finestra di stato, è possibile riconoscere con facilità quali

dati si stanno trasferendo in streaming.

12. ASRock XFast Charger è la tecnologia migliore e più rapida per caricare i propri dispositivi mobili da PC. Grazie alla straordinaria porta USB di XFast Charger, gli utenti sono sicuri di poter godere di un'esperienza di carica rapida coinvolgente in qualsiasi momento. Oltre ai dispositivi Apple, è anche in grado di caricare dispositivi smart con standard BC 1.1. Per maggiori informazioni fare riferimento a pagina 35.
13. ASRock XFast RAM è una nuova funzione inclusa in F-Stream. Utilizza completamente lo spazio che non può essere utilizzato da CPU Windows® 32-bit. ASRock XFast RAM accorcia i tempi di caricamento dei siti visitati in precedenza, rendendo la navigazione più veloce che mai. Inoltre accelera di 5 volte la velocità di Adobe Photoshop. Un altro vantaggio di ASRock XFast RAM è che riduce la frequenza d'accesso alle unità SSD o HDD per allungare la loro durata.
14. ASRock Crashless BIOS permette agli utenti di aggiornare il BIOS senza paura di commettere errori. Se si verifica un blackout durante la procedura di aggiornamento del BIOS, ASRock Crashless BIOS terminerà automaticamente la procedura di aggiornamento del BIOS quando è ripristinata la corrente. Notare che i file del BIOS devono essere collocati nella directory principale del disco USB. Questa funzione è supportata solo dalle porte USB2.0.
15. Anche se questa motherboard offre il controllo stepless, non si consiglia di effettuare l'overclocking. Frequenze del bus del processore diverse da quelle raccomandate possono causare instabilità al sistema o danni al processore e alla scheda madre.
16. Se il processore si surriscalda, il sistema si chiude automaticamente. Prima di riavviare il sistema, assicurarsi che la ventolina CPU della scheda madre funzioni correttamente; scollegare e ricollegare il cavo d'alimentazione. Per migliorare la dissipazione del calore, ricordare di applicare l'apposita pasta siliconica tra il processore e il dissipatore quando si installa il sistema.
17. Intel Rapid Storage Technology Enterprise 3.0 e ASRock XFast RAM non è supportato da Microsoft® Windows® XP / XP 64-bit.
18. EuP, che sta per Energy Using Product (Prodotto che consuma energia) , era una normativa emanata dall'Unione Europea che definiva il consumo energetico del sistema completo. In base all'EuP, l'alimentazione totale del sistema completo deve essere inferiore a 1,00 W quando è spento. Per soddisfare la norma EuP sono necessari un alimentatore e una scheda elettrica predisposti EuP. In base ai suggerimenti Intel l'alimentatore predisposto EuP deve soddisfare lo standard secondo cui l'efficienza energetica in standby di 5 v è più alta del 50% con un consumo di corrente di 100 mA. Per la scelta di un alimentatore predisposto EuP consigliamo di verificare ulteriori dettagli con il produttore.



### 1.3 Setup dei Jumpers

L'illustrazione mostra come sono settati i jumper. Quando il ponticello è posizionato sui pin, il jumper è "CORTOCIRCUITATO". Se sui pin non ci sono ponticelli, il jumper è "APERTO". L'illustrazione mostra un jumper a 3 pin in cui il pin1 e il pin2 sono "CORTOCIRCUITATI" quando il ponticello è posizionato su questi pin.



Jumper	Settaggio del Jumper
--------	----------------------

Resettare la CMOS	
-------------------	--

(CLR CMOS1)	
-------------	--

(vedi p.4 Nr. 25)	
-------------------	--



Nota: CLR CMOS1 permette di azzerare i dati nella CMOS. Per cancellare e ripristinare i parametri del sistema sulla configurazione iniziale, spegnere il computer e scollegare il cavo d'alimentazione dalla presa di corrente. Attendere 15 secondi, poi usare un cappuccio jumper per cortocircuitare il pin 2 ed il pin 3 su CLR CMOS1 per 5 secondi. Tuttavia, si consiglia di non cancellare la CMOS subito dopo avere aggiornato il BIOS. Se si deve azzerare la CMOS quando si è completato l'aggiornamento del BIOS, è necessario per prima cosa avviare il sistema e poi spegnerlo prima di eseguire l'azzeramento della CMOS. Notare che password, data, ore, profilo utente predefinito, GUID e indirizzo MAC saranno cancellati solo se è rimossa la batteria della CMOS.



L'interruttore Clear CMOS (Cancella CMOS) ha la stessa funzione del jumper Clear CMOS.

## 1.4 Collettori e Connettori su Scheda



I collettori ed i connettori su scheda NON sono dei jumper. NON installare cappucci per jumper su questi collettori e connettori. L'installazione di cappucci per jumper su questi collettori e connettori provocherà danni permanenti alla scheda madre!

### Connettori Serial ATA2

(SATA2\_0\_1: vedi p.4 Nr. 13)

(SATA2\_2\_3: vedi p.4 Nr. 12)

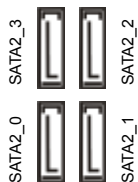

Questi quattro connettori Serial ATA2 (SATA2) supportano cavi dati SATA per dispositivi di immagazzinamento interni. L'interfaccia SATA2 attuale permette velocità di trasferimento dati fino a 3.0 Gb/s.

### Serial ATA3 Connectors

(SATA3\_0\_1: vedi p.4 Nr. 14)

(SATA3\_M0\_M1: vedi p.4 Nr. 15)

(SATA3\_M2\_M3: vedi p.4 Nr. 16)

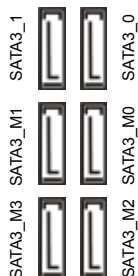

Questi sei connettori Serial ATA3 (SATA3) supportano cavi dati SATA per dispositivi di immagazzinamento interni. L'interfaccia SATA3 attuale permette velocità di trasferimento dati fino a 6.0 Gb/s.

### Cavi dati Serial ATA (SATA)

(Opzionale)



Una o altra estremità del cavo di dati SATA può essere collegata al disco rigido SATA / SATA2 / SATA3 o al connettore di SATA2 / SATA3 su questa cartolina base.

### Cavo d'alimentazione Serial ATA (SATA)

(Opzionale)



Collegare l'estremità nera de cavo di alimentazione SATA al connettore di alimentazione del drive. Poi connettete l'estremità bianca del cavo di alimentazione SATA al connettore power dell'alimentatore.

### Collettore USB 2.0

(9-pin USB\_6\_7)

(vedi p.4 Nr. 29)

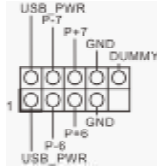

(9-pin USB\_8\_9)

(vedi p.4 Nr. 28)

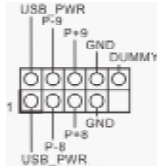

(9-pin USB\_10\_11)

(vedi p.4 Nr. 27)

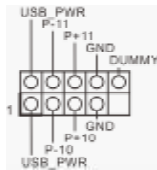

Oltre alle sei porte USB 2.0 predefinite nel pannello I/O, la scheda madre dispone di tre intestazioni USB 2.0. Ciascuna intestazione USB 2.0 supporta due porte USB 2.0.

### Collettore USB 3.0

(19-pin USB3\_5\_6)

(vedi p.4 Nr. 8)

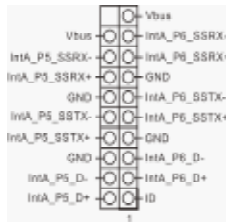

Oltre alle quattro porte USB 3.0 predefinite nel pannello I/O, la scheda madre dispone di due intestazioni USB 3.0. Ciascuna intestazione USB 3.0 supporta due porte USB 3.0.

(19-pin USB3\_7\_8)

(vedi p.4 Nr. 9)

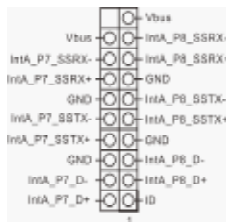

### Collettore modulo infrarossi

(5-pin IR1)

(vedi p.4 Nr. 37)

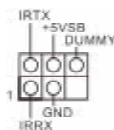

Questo collettore supporta moduli ad infrarossi optional per la trasmissione e la ricezione senza fili.

### Connettore modulo infrarosso consumer

(4-pin CIR1)

(vedi p.4 Nr. 30)



Questo connettore può essere utilizzato per collegare dispositivi all'infrarosso consumer, come ad esempio apparecchiature HI-FI, TV, ecc.

### Connettore audio sul pannello frontale

(9-pin HD\_AUDIO1)

(vedi p.4 Nr. 35)

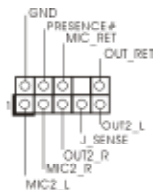

È un'interfaccia per il cavo del pannello audio. Che consente connessione facile e controllo dei dispositivi audio.



1. La caratteristica HDA (High Definition Audio) supporta il rilevamento dei connettori, però il pannello dei cavi sul telaio deve supportare la funzione HDA (High Definition Audio) per far sì che questa operi in modo corretto. Attenersi alle istruzioni del nostro manuale e del manuale del telaio per installare il sistema.
2. Se si utilizza un pannello audio AC'97, installarlo nell'intestazione audio del pannello anteriore, come indicato di seguito:

- A. Collegare Mic\_IN (MIC) a MIC2\_L.
- B. Collegare Audio\_R (RIN) a OUT2\_R e Audio\_L (LIN) ad OUT2\_L.
- C. Collegare Ground (GND) a Ground (GND).
- D. MIC\_RET e OUT\_RET sono solo per il pannello audio HD. Non è necessario collegarli per il pannello audio AC'97.

E. Per attivare il microfono frontale.

Sistema operativo Windows® XP / XP 64-bit:

Selezionare "Mixer". Selezionare "Recorder" (Registratore). Poi, fare clic su "FrontMic" (Microfono frontale).

Sistema operativo Windows® 7 / 7 64-bit / Vista™ / Vista™ 64-bit:

Andare alla scheda "FrontMic" (Microfono frontale) del pannello di controllo Realtek. Regolare la voce "Recording Volume" (Volume registrazione).

### Collettore pannello di sistema

(9-pin PANEL1)

(vedi p.4 Nr. 22)

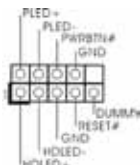

Questo collettore accomoda diverse funzioni di sistema pannello frontale.



Collegare l'interruttore d'alimentazione, l'interruttore di ripristino, l'indicatore di stato del sistema del pannello frontale del telaio a questo header in base all'assegnazione dei pin definita di seguito. Determinare i pin positivi e negativi prima di collegare i cavi.

**PWRBTN (interruttore d'alimentazione):**

Va collegato all'interruttore d'alimentazione del pannello frontale del telaio. Usando l'interruttore d'alimentazione si può configurare il modo in cui si spegne il sistema.

**RESET (interruttore di ripristino):**

Va collegato all'interruttore di ripristino del pannello frontale del telaio. Premere l'interruttore di ripristino per riavviare il sistema se il computer si blocca e non riesce ad eseguire un normale riavvio.

**PLED (LED alimentazione del sistema):**

Va collegato all'indicatore di stato d'alimentazione del pannello frontale del telaio. Il LED è acceso quando il sistema è operativo. Il LED continua a lampeggiare quando il sistema è in stato di standby S1. Il LED è spento quando il sistema è in stato di sospensione /ibernazione S3/S4 oppure spento (S5).

**HDLED (LED attività disco rigido):**

Va collegato al LED attività disco rigido del pannello frontale del telaio. Il LED è acceso quando disco rigido legge e scrive i dati.

Il design del pannello frontale può variare in base ai telai. Il modulo di un pannello frontale può consistere di: interruttore d'alimentazione, interruttore di ripristino, LED d'alimentazione, LED attività disco rigido, casse, eccetera. Quando si collega il modulo del pannello frontale a questo header, assicurarsi che l'assegnazione dei fili e dei pin sia fatta corrispondere in modo appropriato.

**Collettore casse telaio**

(4-pin SPEAKER1)

(vedi p.4 Nr. 21)

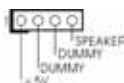

Collegare le casse del telaio a questo collettore.

**LED di accensione**

(3-pin PLED1)

(vedi p.4 Nr. 23)



Collegare il LED di accensione chassi per indicare lo stato di alimentazione del sistema. Il LED è acceso quando il sistema è in funzione. Il LED continua a lampeggiare in stato S1. Il LED è spento in stato S3/S4 o S5 (spegnimento).

## Collettori Chassis ed alimentazione ventola

(4-pin CHA\_FAN1)

(vedi p.4 Nr. 11)

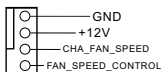

(3-pin CHA\_FAN2)

(vedi p.4 Nr. 20)

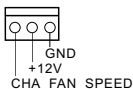

(3-pin CHA\_FAN3)

(vedi p.4 Nr. 17)

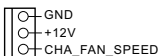

(3-pin PWR\_FAN1)

(vedi p.4 Nr. 44)

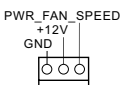

## Connettore ventolina CPU

(4-pin CPU\_FAN1)

(vedi p.4 Nr. 5)

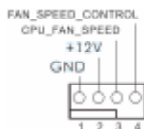

Collegare il cavo della ventolina CPU a questo connettore e far combaciare il filo nero al pin terra.



Sebbene la presente scheda madre disponga di un supporto per ventola CPU a 4 piedini (ventola silenziosa), la ventola CPU a 3 piedini è in grado di funzionare anche senza la funzione di controllo della velocità della ventola. Se si intende collegare la ventola CPU a 3 piedini al connettore della ventola CPU su questa scheda madre, collegarla ai piedini 1-3.

**Piedini 1-3 collegati** ←

Installazione della ventola a 3 piedini

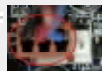

(3-pin CPU\_FAN2)

(vedi p.4 Nr. 6)

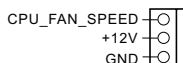

## Connettore alimentazione ATX

(24-pin ATXPWR1)

(vedi p.4 Nr. 7)

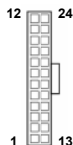

Collegare la sorgente d'alimentazione ATX a questo connettore.



Con questa scheda madre, c'è in dotazione un connettore elettrico ATX a 24 pin, ma può funzionare lo stesso se si adotta un alimentatore ATX a 20 pin. Per usare l'alimentatore ATX a 20 pin, collegare l'alimentatore con il Pin 1 e il Pin 13.

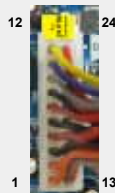

Installazione dell'alimentatore ATX a 20 pin

### Connettore ATX 12 V

(8-pin ATX12V1)

(vedi p.4 Nr. 3)

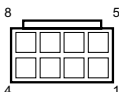

Collegare un alimentatore ATX 12 V a questo connettore.



Sebbene questa scheda madre fornisca un connettore elettrico 8-pin ATX 12V, l'unità può ancora essere funzionante se viene utilizzata una fornitura elettrica tradizionale a 4-pin ATX 12V. Per usare tale fornitura elettrica 4-pin ATX 12V, prego collegare la presa elettrica al Pin 1 e Pin 5.

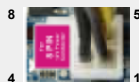

Installazione elettrica 4-Pin ATX 12V

### Connettore alimentazione SLI/XFIRE

(4-pin SLI/XFIRE\_POWER1)

(vedi p.4 Nr. 31)



SLI/XFIRE\_POWER1

Non è necessario usare questo connettore, però deve essere collegato ad un connettore d'alimentazione disco rigido quando sulla scheda madre sono installate contemporaneamente due schede video.

### Intestazione IEEE 1394

(9-pin FRONT\_1394)

(vedi p.4 Nr. 34)

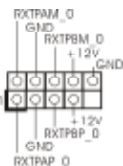

Accanto alla porta di default IEEE 1394 sul pannello I/O, è presente un'intestazione IEEE 1394 (FRONT\_1394) sulla scheda madre. Questa intestazione IEEE 1394 può supportare una porta IEEE 1394.

---

### Collettore porta COM

(9-pin COM1)

(vedi p.4 Nr. 32)

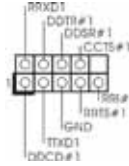

Questo collettore porta COM è utilizzato per supportare il modulo porta COM.

---

### Header HDMI\_SPDIF

(2-pin HDMI\_SPDIF1)

(vedi p.4 Nr. 33)



Header HDMI\_SPDIF, con uscita audio SPDIF su scheda HDMI VGA, consente al sistema di collegare dispositivi per TV digitale HDMI/proiettori/LCD . Collegare il connettore HDMI\_SPDIF della scheda VGA HDMI a questo header.



## Guida all'installazione del pannello frontale USB 3.0

**Punto 1** Preparare il pannello frontale USB 3.0 fornito in dotazione, quattro viti HDD e sei viti telaio.



**Punto 2** Fissare l'unità HDD/SSD 2,5" al pannello frontale USB 3.0 usando quattro viti HDD.



**Punto 3** Installare il pannello frontale USB 3.0 nell'alloggio unità 2,5" del telaio.



**Punto 4** Fissare il pannello frontale USB 3.0 all'alloggio unità usando sei viti telaio.



**Punto 5** Collegare il cavo del pannello frontale USB 3.0 al connettore USB 3.0 (USB3\_5\_6 o USB3\_7\_8) della scheda madre.



**Punto 6** Il pannello frontale USB 3.0 è pronto all'uso.



## Guida di installazione del supporto USB 3.0 posteriore

**Punto 1** Svitare le due viti dal pannello USB 3.0 anteriore.



**Punto 2** Collegare il cavo USB 3.0 e il supporto USB 3.0 posteriore.



**Punto 3** Avvitare le due viti nel supporto USB 3.0 posteriore.



**Punto 4** Inserire il supporto USB 3.0 posteriore nel telaio.



---

## 1.5 Interruttori rapidi

Questa scheda madre ha tre interruttori rapidi: Interruttore di alimentazione, interruttore di reset e interruttore pulizia CMOS, che consentono agli utenti di accendere / spegnere rapidamente o cancellare i valori CMOS.

---

### Interruttore

(PWRBTN)

(vedi p.4 Nr. 18)



L'interruttore di alimentazione è un interruttore rapido che consente agli utenti di accendere/spegnere rapidamente il sistema.

---

### Interruttore di reset

(RSTBTN)

(vedi p.4 Nr. 19)



L'interruttore di reset è un interruttore rapido che consente agli utenti di resettare rapidamente il sistema.

---

### Interruttore pulizia CMOS

(CLRBTN)

(vedi p.5 Nr. 18)



L'interruttore di pulizia CMOS è un interruttore rapido che consente agli utenti di cancellare velocemente i valori CMOS.

---

## 2. Informazioni sul BIOS

La Flash Memory sulla scheda madre contiene le Setup Utility. Quando si avvia il computer, premi <F2> o <Del> durante il Power-On-Self-Test (POST) della Setup utility del BIOS; altrimenti, POST continua con i suoi test di routine. Per entrare il BIOS Setup dopo il POST, riavvia il sistema premendo <Ctl> + <Alt> + <Delete>, o premi il tasto di reset sullo chassis del sistema. Per informazioni più dettagliate circa il Setup del BIOS, fare riferimento al Manuale dell'Utente (PDF file) contenuto nel cd di supporto.

## 3. Software di supporto e informazioni su CD

Questa scheda madre supporta vari sistemi operativi Microsoft® Windows®: 7 / 7 64-bit / Vista™ / Vista™ 64-bit / XP / XP 64-bit. Il CD di supporto a corredo della scheda madre contiene i driver e utilità necessari a potenziare le caratteristiche della scheda.

Inserire il CD di supporto nel lettore CD-ROM. Se la funzione "AUTORUN" è attivata nel computer, apparirà automaticamente il Menù principale. Se il Menù principale non appare automaticamente, posizionarsi sul file "ASSETUP.EXE" nel CESTINO del CD di supporto e cliccare due volte per visualizzare i menù.

# 1. Introducción

Gracias por su compra de **Fatal1ty X79 Professional Series** placa madre, una placa de confianza producida bajo el control de calidad estricto y persistente. La placa madre provee realización excelente con un diseño robusto conforme al compromiso de calidad y resistencia de ASRock.

Esta Guía rápida de instalación contiene una introducción a la placa base y una guía de instalación paso a paso. Puede encontrar una información más detallada sobre la placa base en el manual de usuario incluido en el CD de soporte.



Porque las especificaciones de la placa madre y el software de BIOS podrían ser actualizados, el contenido de este manual puede ser cambiado sin aviso. En caso de cualquier modificación de este manual, la versión actualizada estará disponible en el website de ASRock sin previo aviso. También encontrará las listas de las últimas tarjetas VGA y CPU soportadas en la página web de ASRock.

Website de ASRock <http://www.asrock.com>

Si necesita asistencia técnica en relación con esta placa base, visite nuestra página web con el número de modelo específico de su placa.

[www.asrock.com/support/index.asp](http://www.asrock.com/support/index.asp)

## 1.1 Contenido de la caja

Placa base **Fatal1ty X79 Professional Series**

(Factor forma ATX: 30,5 cm x 24,4 cm, 12,0" x 9,6")

Guía de instalación rápida de **Fatal1ty X79 Professional Series**

CD de soporte de **Fatal1ty X79 Professional Series**

Seis cables de datos Serial ATA (SATA) (Opcional)

Dos cables de alimentación HDD Serial ATA (SATA) (Opcional)

Una protección I/O

Una panel frontal USB 3.0

Cuatro de disco duro tornillos

Seises chasis tornillos

Una Soporte USB 3.0 posterior

Dos tarjeta ASRock SLI\_Bridge

Una tarjeta ASRock SLI\_Bridge\_3S

Una tarjeta SLI Bridge de 3 direcciones de ASRock



### ASRock le recuerda...

Para mejorar el rendimiento en Windows® 7 / 7 64 bits / Vista™ / Vista™ 64 bits, es recomendable establecer la opción del BIOS de la configuración de almacenamiento en el modo AHCI. Para obtener detalles sobre la configuración del BIOS, consulte el "Manual del usuario" que se encuentra en nuestro CD de soporte.

## 1.2 Especificación

<b>Plataforma</b>	<ul style="list-style-type: none"> <li>- Factor forma ATX: 30,5 cm x 24,4 cm, 12,0" x 9,6"</li> <li>- Diseño de condensadores de oro de calidad superior (condensadores de polímero conductor de alta calidad de fabricación 100% japonesa)</li> </ul>
<b>Procesador</b>	<ul style="list-style-type: none"> <li>- Admite la familia de procesadores Intel® Core™ i7 para el zócalo LGA 2011</li> <li>- Diseño de alimentación digital</li> <li>- Avanzado diseño de fases de potencia 16 + 2</li> <li>- Admite la tecnología Intel® Turbo Boost 2.0 Technology</li> <li>- Admite tecnología Hyper Threading (ver <b>ATENCIÓN 1</b>)</li> <li>- Admite tecnología de aumento de velocidad liberada</li> </ul>
<b>Chipset</b>	- Intel® X79
<b>Memoria</b>	<ul style="list-style-type: none"> <li>- Tecnología de memoria DDR3 en cuatro canales (ver <b>ATENCIÓN 2</b>)</li> <li>- 4 x DDR3 DIMM slots</li> <li>- Apoya DDR3 2400+(OC)/2133(OC)/1866(OC)/1600/1333/1066 non-ECC, memoria de un-buffered</li> <li>- Admite DDR3 ECC, memoria sin búfer con procesadores Intel® Workstation 1S Xeon® de la serie E5 16xx/26xx/46xx en zócalo LGA 2011</li> <li>- Máxima capacidad de la memoria del sistema: 32GB (vea <b>ATENCIÓN 3</b>)</li> <li>- Compatible con Intel® Extreme Memory Profile (XMP)1.3/1.2</li> </ul>
<b>Ranuras de Expansión</b>	<ul style="list-style-type: none"> <li>- 4 x ranuras PCI Express 3.0 x16 (PCI E1/PCI E2/PCI E4/PCI E5: modo x16/8/16/0; modo x16/8/8/8) (vea <b>ATENCIÓN 4</b>)</li> <li>- 1 x ranuras PCI Express 2.0 x1</li> <li>- 2 x ranura PCI</li> <li>- Compatible con AMD Quad CrossFireX™, 4-Way CrossFireX™, 3-Way CrossFireX™ y CrossFireX™</li> <li>- Compatible con NVIDIA® Quad SLI™, 4-Way SLI™, 3-Way SLI™ y SLI™</li> </ul>
<b>Audio</b>	<ul style="list-style-type: none"> <li>- 7.1 CH HD Audio con Protección de Contenido (Realtek ALC898 Audio Codec)</li> <li>- Compatible con audio Blu-ray de alta calidad</li> <li>- Compatible con THX TruStudio™</li> </ul>
<b>LAN</b>	<ul style="list-style-type: none"> <li>- PCIE x1 Gigabit LAN 10/100/1000 Mb/s</li> <li>- Broadcom BCM57781</li> <li>- Soporta Wake-On-LAN</li> <li>- Compatible con Ethernet 802.3az de bajo consumo</li> </ul>

	<p>energético</p> <ul style="list-style-type: none"> <li>- Compatible con PXE</li> </ul>
<b>Entrada/Salida de Panel Trasero</b>	<p>I/O Panel</p> <ul style="list-style-type: none"> <li>- 1 x puerto de teclado PS/2</li> <li>- 1 x puerto de salida coaxial SPDIF</li> <li>- 1 x puerto de salida óptica SPDIF</li> <li>- 5 x puertos USB 2.0 predeterminados</li> <li>- 1 x puerto de ratón Fatal1ty (USB 2.0)</li> <li>- 2 x Conectores eSATA3</li> <li>- 4 x puertos USB 3.0 predeterminados</li> <li>- 1 x Puerto LAN RJ-45 con LED (LED de ACCIÓN/ENLACE y LED de VELOCIDAD)</li> <li>- 1 x puerto IEEE 1394</li> <li>- 1 x conmutador de borrado de memoria CMOS</li> <li>- Conexión de audio: Altavoz lateral / Altavoz trasero / Central/Bajos / Entrada de línea / Altavoz frontal / Micrófono (ver <b>ATENCIÓN 5</b>)</li> </ul>
<b>SATA3</b>	<ul style="list-style-type: none"> <li>- 2 x conectores SATA3 de 6,0 Gb/s con chip Intel® X79 con funciones RAID (RAID 0, RAID 1, RAID 5, RAID 10 y Intel Rapid Storage3.0), NCQ, AHCI y de "Hot Plug" (conexión en caliente)</li> <li>- 4 x conectores SATA3 de 6,0 Gb/s con chip Marvell SE9172 con funciones RAID (RAID 0 y RAID 1), NCQ, AHCI y de "Hot Plug" (conexión en caliente)</li> </ul>
<b>USB 3.0</b>	<ul style="list-style-type: none"> <li>- 4 x puertos USB 3.0 traseros de TI®, compatible con USB 1.0/2.0/3.0 de hasta 5 GB/s</li> <li>- 2 x cabecera USB 3.0 delantera (compatible con 4 puertos USB 3.0) de TI®, compatible con USB 1.0/2.0/3.0 de hasta 5 GB/s</li> </ul>
<b>Conectores</b>	<ul style="list-style-type: none"> <li>- 4 x conexiones SATA2, admiten una velocidad de transferencia de datos de hasta 3,0Gb/s, soporta RAID (RAID 0, RAID 1, RAID 5, RAID 10 y Intel Rapid Storage3.0), NCQ, AHCI y "Conexión en caliente"</li> <li>- 6 x conexiones SATA3, admiten una velocidad de transferencia de datos de hasta 6,0Gb/s</li> <li>- 1 x Cabezal de Módulo Infrarrojos</li> <li>- 1 x Base de conexiones del módulo de infrarrojos para el consumidor</li> <li>- 1x En-tête de port COM</li> <li>- 1 x cabecera HDMI_SPDIF</li> <li>- 1 x cabecera IEEE 1394</li> </ul>

	<ul style="list-style-type: none"> <li>- 1 x cabecera de indicador LED de encendido</li> <li>- Conector de ventilador de CPU / chasis / alimentación</li> <li>- 24-pin cabezal de alimentación ATX</li> <li>- 8-pin conector de ATX 12V power</li> <li>- Cabezal de alimentación SLI/XFIRE</li> <li>- Conector de audio de panel frontal</li> <li>- 3 x Cabezal USB 2.0 (admite 6 puertos USB 2.0 adicionales)</li> <li>- 2 x Cabezal USB 3.0 (admite 4 puertos USB 3.0 adicionales)</li> <li>- 1 x Dr. Debug (indicador LED de avería de 7 segmentos)</li> </ul>
<b>Conmutador rápido</b>	<ul style="list-style-type: none"> <li>- 1 x conmutador de encendido con indicador LED</li> <li>- 1 x conmutador de reinicio con indicador LED</li> <li>- 1 x conmutador de borrado de memoria CMOS con indicador LED</li> </ul>
<b>BIOS</b>	<ul style="list-style-type: none"> <li>- 64Mb AMI BIOS legal UEFI AMI compatible con GUI</li> <li>- Soporta "Plug and Play"</li> <li>- ACPI 1.1 compliance wake up events</li> <li>- Soporta "jumper free"</li> <li>- Soporta SMBIOS 2.3.1</li> <li>- Múltiple ajuste de CPU, VCCSA, DRAM, VTT, CPU PLL, PCH1.1V, PCH1.5V Voltage</li> </ul>
<b>CD de soport</b>	<ul style="list-style-type: none"> <li>- Controladores, utilidades, software de antivirus (versión de prueba), Prueba de CyberLink MediaEspresso 6.5, conjunto de aplicaciones ASRock (Conjunto multimedia ASRock MAGIX - OEM)</li> </ul>
<b>Característica Única</b>	<ul style="list-style-type: none"> <li>- F-Stream (vea <b>ATENCIÓN 6</b>)</li> <li>- ASRock Instant Boot</li> <li>- ASRock Instant Flash (vea <b>ATENCIÓN 7</b>)</li> <li>- ASRock APP Charger (vea <b>ATENCIÓN 8</b>)</li> <li>- ASRock SmartView (vea <b>ATENCIÓN 9</b>)</li> <li>- ASRock XFast USB (vea <b>ATENCIÓN 10</b>)</li> <li>- ASRock XFast LAN (vea <b>ATENCIÓN 11</b>)</li> <li>- XFast Charger de ASRock (vea <b>ATENCIÓN 12</b>)</li> <li>- ASRock XFast RAM (vea <b>ATENCIÓN 13</b>)</li> <li>- ASRock Crashless BIOS (vea <b>ATENCIÓN 14</b>)</li> <li>- Amplificador Híbrido: <ul style="list-style-type: none"> <li>- Stepless control de frecuencia de CPU (vea <b>ATENCIÓN 15</b>)</li> <li>- ASRock U-COP (vea <b>ATENCIÓN 16</b>)</li> <li>- Protección de Falla de Inicio (B.F.G..)</li> </ul> </li> <li>- Indicador LED nocturno</li> </ul>
<b>Monitor</b>	<ul style="list-style-type: none"> <li>- Sensibilidad a la temperatura del procesador</li> </ul>

<b>Hardware</b>	<ul style="list-style-type: none"> <li>- Sensibilidad a la temperatura de la placa madre</li> <li>- Taquímetros de los ventiladores del procesador y del CPU / chasis / alimentación</li> <li>- Ventilador silencioso del procesador y el chasis (ajuste automático de la velocidad del ventilador del chasis en función de la temperatura del procesador)</li> <li>- Control de ajuste de la velocidad del ventilador de la CPU / chasis</li> <li>- Monitor de Voltaje: +12V, +5V, +3.3V, Vcore</li> </ul>
<b>OS</b>	- En conformidad con Microsoft® Windows® 7 / 7 64 bits / Vista™ / Vista™ 64 bits / XP / XP 64 bits (vea <b>ATENCIÓN 17</b> )
<b>Certificaciones</b>	<ul style="list-style-type: none"> <li>- FCC, CE, WHQL</li> <li>- Cumple con la directiva ErP/EuP (se requiere una fuente de alimentación que cumpla con la directiva ErP/EuP) (vea <b>ATENCIÓN 18</b>)</li> </ul>

\* Para más información sobre los productos, por favor visite nuestro sitio web:  
<http://www.asrock.com>

#### **ADVERTENCIA**

Tenga en cuenta que hay un cierto riesgo implícito en las operaciones de aumento de la velocidad del reloj, incluido el ajuste del BIOS, aplicando la tecnología de aumento de velocidad liberada o utilizando las herramientas de aumento de velocidad de otros fabricantes. El aumento de la velocidad puede afectar a la estabilidad del sistema e, incluso, dañar los componentes y dispositivos del sistema. Esta operación se debe realizar bajo su propia responsabilidad y Ud. debe asumir los costos. No asumimos ninguna responsabilidad por los posibles daños causados por el aumento de la velocidad del reloj.

## **ATENCIÓN !**

1. Por favor consulte página 67 del Manual del Usuario en el soporte CD sobre la configuración de Hyper-Threading Technology.
2. Esta placa base soporta Tecnología de memoria DDR3 en cuatro canales. Antes de implementar la Tecnología de memoria DDR3 en cuatro canales, asegúrese de leer la guía de instalación de módulos de memoria en la página 18 para su correcta instalación.
3. Debido a las limitaciones del sistema, el tamaño real de la memoria debe ser inferior a 4GB para que el sistema pueda funcionar bajo Windows® 7 / Vista™ / XP. Para equipos con Windows® OS con CPU de 64-bit, no existe dicha limitación. Puede usar ASRock XFast RAM para utilizar la memoria que no puede usar Windows®.



4. Actualmente, el procesador Intel® Socket 2011 Sandy Bridge-E no admite PCIE 3.0, pero que esta placa base ya viene preparada con el hardware PCIE 3.0. La activación de PCIE 3.0 depende de la CPU de Intel. Consulte el sitio Web de Intel para obtener información acerca de las actualizaciones inversiones de CPU próximas.
5. Para la entrada de micrófono, esta placa madre ofrece soporte para modos estéreo y mono. Para salida de audio, este placa madre ofrece soporte para modos de 2 canales, 4 canales, 6 canales y 8 canales. Consulte la tabla en la página 5 para una conexión correcta.
6. F-Stream es una herramienta todo en uno que permite realizar ajustes precisos en diferentes funciones del sistema mediante una interfaz sencilla, que incluye supervisión de hardware, control de ventiladores, función de aumento de la velocidad del reloj, DNA OC y IES. La función de supervisión de hardware, muestra las principales lecturas del sistema. La función de control de los ventiladores, muestra la velocidad y la temperatura de los ventiladores y permite ajustarlas. La función de aumento de la velocidad del reloj, permite aumentar la frecuencia de la CPU para conseguir un rendimiento óptimo del sistema. La función DNA OC permite guardar la configuración OC como un perfil y compartirla con sus amigos. Después, sus amistados pueden cargar el perfil OC en sus propios sistemas para obtener la misma configuración OC. En el protector de energía inteligente (IES, Intelligent Energy Saver), el regulador de voltaje puede reducir el número de fases de salida para mejorar la eficiencia cuando los núcleos de la CPU están inactivos sin que el rendimiento de cálculo disminuya.
7. ASRock Instant Flash es una utilidad de programación del BIOS que se encuentra almacenada en la memoria Flash ROM. Esta sencilla herramienta de actualización de BIOS le permitirá actualizar el BIOS del sistema sin necesidad de acceder a ningún sistema operativo, como MS-DOS o Windows®. Gracias a esta utilidad, sólo necesitará pulsar <F6> durante la fase POST o pulsar <F2> para acceder al menú de configuración del BIOS y a la utilidad ASRock Instant Flash. Ejecute esta herramienta y guarde el archivo correspondiente al sistema BIOS nuevo en su unidad flash USB, unidad de disco flexible o disco duro para poder actualizar el BIOS con sólo pulsar un par de botones, sin necesidad de preparar un disco flexible adicional ni utilizar complicadas utilidades de programación. Recuerde que la unidad flash USB o disco duro utilizado debe disponer del sistema de archivos FAT32/16/12.
8. Si desea una forma más rápida y menos limitada de cargar sus dispositivos de Apple; como por ejemplo iPhone, iPad o iPod Touch, ASRock ha creado una fantástica solución para usted: ASRock APP Charger. Simplemente mediante la instalación del controlador de APP Charger, podrá cargar su iPhone de forma mucho más rápida que antes, hasta un 40%, desde su equipo. ASRock APP Charger le permite cargar de forma rápida muchos dispositivos de Apple simultáneamente e incluso podrá continuar la carga cuando su PC entre en modo de espera (S1),

suspendido en RAM (S3), modo de hibernación (S4) o se apague (S5). Una vez instalado el controlador de APP Charger, podrá disfrutar fácilmente de una fantástica carga sin precedentes.

Sitio web de ASRock: <http://www.asrock.com/Feature/AppCharger/index.asp>

9. SmartView, una nueva función del explorador de Internet, es la página de inicio inteligente para IE que combina los sitios Web más visitados, su historial, sus amigos de Facebook y su fuente de noticias en una vista mejorada para disfrutar de una experiencia en Internet más personal. Las placas base ASRock están exclusivamente equipadas con la utilidad SmartView que le ayuda a seguir en contacto con sus amigos sobre la marcha. Para utilizar la función SmartView asegúrese de que la versión de su sistema operativo es Windows® 7 / 7 64 bits / Vista™ / Vista™ 64 bits y que la versión de su explorador es IE8. Sitio Web de ASRock: <http://www.asrock.com/Feature/SmartView/index.asp>
10. ASRock XFast USB puede aumentar el rendimiento de los dispositivos de almacenamiento USB. El rendimiento depende de las propiedades del dispositivo.
11. ASRock XFast LAN proporciona un acceso a Internet más rápido, que incluye las ventajas que se indican a continuación. Priorización de aplicaciones LAN: Puede configurar la prioridad de las aplicaciones de forma ideal y/o agregar nuevos programas. Menor latencia en los juegos: Después de aumentar la prioridad de los juegos en línea, se puede reducir la latencia en los mismos. Gestionar el tráfico: Puede ver video en alta definición de Youtube y descargar archivos simultáneamente. Análisis de sus datos en tiempo real: Con la ventana de estado, puede reconocer fácilmente qué transmisiones en secuencias se están transfiriendo actualmente.
12. XFast Charger de ASRock es la mejor tecnología y la más rápida para cargar dispositivos móviles a través de su PC. Con el magnífico puerto USB de XFast Charger, los usuarios disfrutarán con toda seguridad de una experiencia de carga rápida en cualquier momento. Además de dispositivos Apple, también es capaz de cargar los dispositivos inteligentes estándar BC 1.1. Consulte la página 35 para obtener más detalles.
13. ASRock XFast RAM es una nueva función incluida en F-Stream. Utiliza completamente el espacio de memoria que no se puede utilizar con procesadores de 32 bits en sistemas operativos Windows®. ASRock XFast RAM acorta el tiempo de carga de los sitios Web visitados con anterioridad, lo que permite navegar por Internet mucho más rápido que nunca. Además, también aumenta la velocidad de Adobe Photoshop 5 veces. Otra ventaja de ASRock XFast RAM es que reduce la frecuencia de acceso a las unidades de estado sólido (SSD) o las unidades de disco duro (HDD), lo que prolonga el período de vida útil de las mismas.
14. ASRock Crashless BIOS le permite a los usuarios actualizar su BIOS sin miedo de que ocurra un fallo. Si ocurre una interrupción en el suministro de energía durante el proceso de actualización del BIOS, ASRock

---

Crashless BIOS finalizará de manera automática el proceso de actualización una vez se restablezca en suministro de energía. Tome en cuenta que los archivos del BIOS deben colocarse en el directorio raíz de su disco USB. Sólo los puertos USB 2.0 soportan esta función.

15. Aunque esta placa base ofrece un control completo, no es recomendable forzar la velocidad. Las frecuencias de bus de la CPU distintas a las recomendadas pueden causar inestabilidad en el sistema o dañar la CPU.
16. Cuando la temperatura de CPU está sobre-elevada, el sistema va a apagarse automáticamente. Antes de reanudar el sistema, compruebe si el ventilador de la CPU de la placa base funciona apropiadamente y desconecte el cable de alimentación, a continuación, vuelva a conectarlo. Para mejorar la disipación de calor, acuérdesse de aplicar thermal grease entre el procesador y el disipador de calor cuando usted instala el sistema de PC.
17. Intel Rapid Storage Technology Enterprise 3.0 y ASRock XFast RAM no se admite en Microsoft® Windows® XP y XP 64 bits.
18. EuP, siglas de Energy Using Product (Producto que Utiliza Energía), es una disposición regulada por la Unión Europea para establecer el consumo total de energía de un sistema. Según la disposición EuP, la alimentación de CA total para el sistema completo ha de ser inferior a 1,00W en modo apagado. Para cumplir con el estándar EuP, se requieren una placa base y una fuente de alimentación que cumplan con la directiva EuP. Según las directrices de Intel, una fuente de alimentación que cumpla con la directiva EuP debe satisfacer el estándar, es decir, la eficiencia de energía de 5v en modo de espera debería ser mayor del 50% con un consumo de corriente de 100mA. Para seleccionar una fuente de alimentación que cumpla la directiva EuP, le recomendamos que consulte con el fabricante de la fuente de alimentación para obtener más detalles.

### 1.3 Setup de Jumpers

La ilustración muestra como los jumpers son configurados. Cuando haya un jumper-cap sobre los pins, se dice que el jumper está "Short". No habiendo jumper cap sobre los pins, el jumper está "Open". La ilustración muestra un jumper de 3 pins cuyo pin 1 y pin 2 están "Short".



#### Jumper

#### Setting

##### Limpiar CMOS

(CLRCMOS1, jumper de 3 pins)  
(ver p.4, No. 25)



Valor predeterminado



Restablecimiento de la CMOS

Nota: CLRCMOS1 permite borrar los datos de la memoria CMOS. Para borrar los parámetros del sistema y restablecer la configuración predeterminada de los mismos, apague el equipo y desenchufe el cable de alimentación de la toma de corriente eléctrica. Deje que transcurran 15 segundos y, después, utilice un puente para cortocircuitar los contactos 2 y 3 de CLRCMOS1 durante 5 segundos. No borre la memoria CMOS justamente después de actualizar el BIOS. Si necesita borrar la memoria CMOS justamente después de actualizar el BIOS, debe iniciar primero el sistema y, a continuación, cerrarlo antes de llevar a cabo el borrado de dicha memoria. Tenga en cuenta que la contraseña, la fecha, la hora, el perfil predeterminado del usuario, el GUID 1394 y la dirección MAC solamente se borrará si la batería CMOS se quita.



El conmutador Borrar CMOS tiene la misma función que el puente Borrar CMOS.

## 1.4 Cabezales y Conectores en Placas



Los conectores y cabezales en placa NO son puentes. NO coloque las cubiertas de los puentes sobre estos cabezales y conectores. El colocar cubiertas de puentes sobre los conectores y cabezales provocará un daño permanente en la placa base.

### Conexiones de serie ATA2

(SATA2\_0\_1: vea p.4, N. 13)

(SATA2\_2\_3: vea p.4, N. 12)

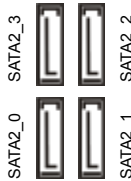

Estas cuatro conexiones de serie ATA2 (SATA2) admiten cables SATA para dispositivos de almacenamiento internos. La interfaz SATA2 actual permite una velocidad de transferencia de 3.0 Gb/s.

### Conexiones de serie ATA3

(SATA3\_0\_1: vea p.4, N. 14)

(SATA3\_M0\_M1: vea p.4, N. 15)

(SATA3\_M2\_M3: vea p.4, N. 16)

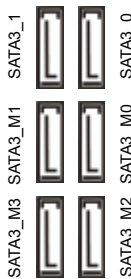

Estas seis conexiones de serie ATA3 (SATA3) admiten cables SATA para dispositivos de almacenamiento internos. La interfaz SATA2 / SATA3 actual permite una velocidad de transferencia de 6.0 Gb/s.

### Cable de datos de serie ATA (SATA)

(Opcional)



Cualquier extremo del cable de los datos de SATA puede ser conectado con el disco duro de SATA / SATA2 / SATA3 o el conector de SATA2 / SATA3 en esta placa base.

### Cable de alimentación de serie ATA (SATA)

(Opcional)

Connettere all'alimentazione dei dischi SATA



Connettere al gruppo di alimentazione

Conecte el extremo negro del cable de SATA al conector de energía de la unidad. A continuación, conecte el extremo blanco del cable de



## Base de conexiones del módulo de infrarrojos para el consumidor

(4-pin CIR1)

(vea p.4, N. 30)



Esta base de conexiones se puede utilizar para conectar dispositivos infrarrojos del consumidor opcionales, como por ejemplo equipos HI-FI, descodificadores de TV, etc.

## Conector de audio de panel frontal

(9-pin HD\_AUDIO1)

(vea p.4, N. 35)

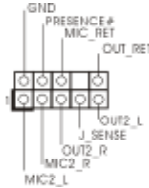

Este es una interface para cable de audio de panel frontal que permite conexión y control conveniente de aparatos de Audio.



1. El Audio de Alta Definición soporta la detección de conector, pero el cable de panel en el chasis debe soportar HDA para operar correctamente. Por favor, siga las instrucciones en nuestro manual y en el manual de chasis para instalar su sistema.
2. Si utiliza el panel de sonido AC'97, instálelo en la cabecera de sonido del panel frontal de la siguiente manera:
  - A. Conecte Mic\_IN (MIC) a MIC2\_L.
  - B. Conecte Audio\_R (RIN) a OUT2\_R y Audio\_L (LIN) en OUT2\_L.
  - C. Conecte Ground (GND) a Ground (GND).
  - D. MIC\_RET y OUT\_RET son sólo para el panel de sonido HD. No necesitará conectarlos al panel de sonido AC'97.
  - E. Activación del micrófono frontal.

En sistemas operativos Windows® XP / XP 64-bit:

Seleccione "Mixer" (Mezclador). Seleccione "Recorder" (Grabadora).

A continuación, haga clic en "FrontMic" (Micrófono frontal).

En sistemas operativos Windows® 7 / 7 64-bit / Vista™ / Vista™ 64-bit:

Acceda a la ficha "FrontMic" (Micrófono frontal) del panel de control Realtek. Ajuste la posición del control deslizante "Recording Volume" (Volumen de grabación).

## Cabezal de panel de sistema

(9-pin PANEL1)

(vea p.4, N. 22)

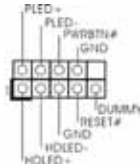

Este cabezar acomoda varias funciones de panel frontal de sistema.



Conecte el interruptor de alimentación, el interruptor de restablecimiento y el indicador de estado del sistema situados en el chasis con esta cabecera en función de las siguientes asignaciones de contacto. Preste atención a los contactos positivos y negativos antes de conectar los cables.

**PWRBTN (interruptor de alimentación):**

Conecte el interruptor de encendido situado en el panel frontal del chasis. Puede configurar la forma de apagar su sistema mediante el interruptor de alimentación.

**RESTABLECER (interruptor de restablecimiento):**

Conecte el interruptor de restablecimiento situado en el panel frontal del chasis. Pulse el interruptor de restablecimiento para restablecer el equipo si se bloquea y no se reinicia con normalidad.

**PLED (LED de alimentación del sistema):**

Conecte el indicador de estado de alimentación situado en el panel frontal del chasis. El LED se enciende cuando el sistema esté en funcionamiento. El LED parpadea cuando el sistema se encuentre en estado de suspensión S1. El LED se apaga cuando el sistema se encuentre en estado de suspensión S3/S4 o se apaga (S5).

**HDLED (LED de actividad del disco duro):**

Conecte el LED de actividad de disco duro situado en el panel frontal del chasis. El LED se enciende cuando el disco duro esté leyendo o escribiendo datos.

Es posible que el diseño del panel frontal varíe en función del chasis. Un módulo del panel frontal consiste principalmente de interruptor de alimentación, interruptor de restablecimiento, LED de alimentación, LED de actividad del disco duro, altavoz, etc. Al conectar el módulo del panel frontal del chasis a esta cabecera, asegúrese de que las asignaciones de cables y las asignaciones de contactos coincidan correctamente.

**Cabezal del altavoz del chasis**

(4-pin SPEAKER1)

(vea p.4, N. 21)

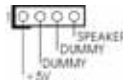

Conecte el altavoz del chasis a su cabezal.



## Cabecera de indicador LED de encendido

(3-pin PLED1)

(vea p.4, N. 23)



Conecte el indicador LED de encendido del chasis a esta cabecera para conocer el estado de encendido del sistema. El indicador LED se encenderá si el sistema se encuentra en funcionamiento. El indicador LED parpadeará en el estado S1. El indicador LED se apagará en los estados S3/S4 o S5 (apagado).

## Conectores de ventilador de chasis

/ alimentación

(4-pin CHA\_FAN1)

(vea p.4, N. 11)

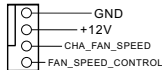

(3-pin CHA\_FAN2)

(vea p.4, N. 20)

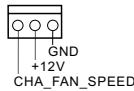

(3-pin CHA\_FAN3)

(vea p.4, N. 17)

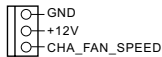

(3-pin PWR\_FAN1)

(vea p.4, N. 44)

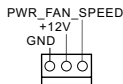

Por favor, conecte los cables del ventilador a los conectores de ventilador, haciendo coincidir el cable negro con la patilla de masa. CHA\_FAN1, CHA\_FAN2 y CHA\_FAN3 admiten control de ventilador.

## Conector del ventilador de la CPU

(4-pin CPU\_FAN1)

(vea p.4, N. 5)

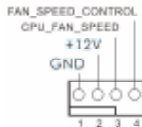

Conecte el cable del ventilador de la CPU a este conector y haga coincidir el cable negro con el conector de tierra.



Aunque esta placa base proporciona compatibilidad para un ventilador (silencioso) de procesador de 4 contactos, el ventilador de procesador de 3 contactos seguirá funcionando correctamente incluso sin la función de control de velocidad de ventilador. Si pretende enchufar el ventilador de procesador de 3 contactos en el conector del ventilador de procesador de esta placa base, conéctelo al contacto 1-3.

**Contacto 1-3 conectado** ←

Instalación del ventilador de 3 contactos

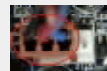

(3-pin CPU\_FAN2)  
(vea p.4, N. 6)

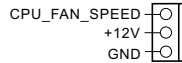

### Cabezal de alimentación ATX

(24-pin ATXPWR1)  
(vea p.4, N. 7)

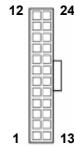

Conecte la fuente de alimentación ATX a su cabezal.



A pesar de que esta placa base incluye un conector de alimentación ATX de 24 pins, ésta puede funcionar incluso si utiliza una fuente de alimentación ATX de 20 pins tradicional. Para usar una fuente de alimentación ATX de 20 pins, por favor, conecte su fuente de alimentación usando los Pins 1 y 13.

Instalación de una Fuente de Alimentación ATX de 20 Pins

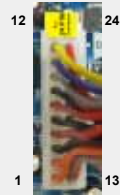

### Cabezal de alimentación ATX 12V

(8-pin ATX12V1)  
(vea p.4, N. 3)

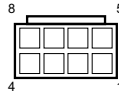

Conecte la fuente de alimentación ATX 12V a su cabezal.



Aunque esta placa base proporciona un conector de energía de 8-pin ATX 12V, puede todavía trabajar si usted adopta un fuente tradicional de energía de 4-pin ATX 12V. Para usar el fuente de energía de 4-pin ATX 12V, por favor conecte su fuente de energía junto con Pin 1 y Pin 5.

Instalación de Fuente de Energía de 4-Pin ATX 12V



### Conector de alimentación SLI/XFIRE

(4-pin SLI/XFIRE\_POWER1)  
(vea p.4, N. 31)



SLI/XFIRE\_POWER1

No es necesario utilizar este conector. Conéctelo al conector de alimentación del disco duro cuando se conecten dos tarjetas gráficas a esta placa base al mismo tiempo.

---

### Jefe de IEEE 1394

(9-pin FRONT\_1394)

(ver p.4, N. 34)

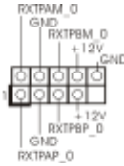

Además de un puerto de IEEE 1394 del defecto en el panel de I/O, hay un jefe de IEEE 1394 (FRONT\_1394) en esta placa base. Este jefe de IEEE 1394 puede apoyar un puerto de IEEE 1394.

---

### Cabezal del puerto COM

(9-pin COM1)

(vea p.4, N. 32)

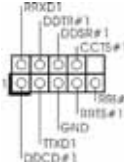

Este cabezal del puerto COM se utiliza para admitir un módulo de puerto COM.

---

### Cabecera HDMI\_SPDIF

(HDMI\_SPDIF1 de 2 pin)

(vea p.4, N. 35)



Cabecera HDMI\_SPDIF. Ofrece una salida SPDIF la tarjeta VGA HDMI, permite al sistema conectarse a dispositivos de TV Digital HDMI / proyectores / Dispositivos LCD. Conecte el conector HDMI\_SPDIF de la tarjeta VGA HDMI a esta cabecera.

## Guía de instalación del Panel frontal USB 3.0

**Paso 1** Prepare el Panel frontal USB 3.0, los cuatro tornillos para unidad HDD y los seis tornillos de fijación al chasis suministrados.



**Paso 2** Atornille la unidad HDD/SSD de 2,5" al Panel frontal USB 3.0 empleando los cuatro tornillos para unidad HDD.



**Paso 3** Instale el Panel frontal USB 3.0 en la bahía de unidad de 2,5" del chasis.



**Paso 4** Atornille el Panel frontal USB 3.0 a la bahía de unidad empleando los seis tornillos de fijación al chasis.



**Paso 5** Conecte el cable del Panel frontal USB 3.0 a la cabecera USB 3.0 (USB3\_5\_6 o USB3\_7\_8) de la placa base.



**Paso 6** El Panel frontal USB 3.0 quedará así listo para su uso.



## Guía de instalación del soporte USB 3.0 posterior

**Paso 1** Desatornille los dos tornillos del panel USB 3.0 frontal.



**Paso 2** Coloque el cable USB 3.0 el soporte USB 3.0 posterior juntos.



**Paso 3** Atornille los dos tornillos en el soporte USB 3.0 posterior.



**Paso 4** Coloque el soporte USB 3.0 posterior en el chasis.



---

## 1.5 Conmutadores rápidos

Esta placa base dispone de tres conmutadores rápidos: conmutador de encendido, conmutador de reinicio y conmutador de borrado de memoria CMOS. Dichos conmutadores permiten al usuario encender / apagar o reiniciar el sistema, o bien borrar el contenido de la memoria CMOS.

---

### Conmutador de encendido

(PWRBTN)

(vea p.4, N. 18)



El conmutador de reinicio es un conmutador rápido que permite al usuario reiniciar rápidamente el sistema.

---

### Conmutador de reinicio

(RSTBTN)

(vea p.4, N. 19)



El conmutador de borrado de memoria CMOS es un conmutador rápido que permite al usuario borrar rápidamente el contenido de la memoria CMOS.

---

### Conmutador de borrado de memoria CMOS

(CLRBTN)

(vea p.5, N. 18)



El conmutador de encendido es un conmutador rápido que permite al usuario encender / apagar rápidamente el sistema.

---

## 2. BIOS Información

El Flash Memory de la placa madre deposita SETUP Utility. Durante el Power-Up (POST) apriete <F2> o <Del> para entrar en la BIOS. Si usted no oprime ninguna tecla, el POST continúa con sus rutinas de prueba. Si usted desea entrar en la BIOS después del POST, por favor reinicie el sistema apretando <Ctl> + <Alt> + <Borrar>, o apretando el botón Reset en el panel del ordenador. Para información detallada sobre como configurar la BIOS, por favor refiérase al Manual del Usuario (archivo PDF) contenido en el CD.

## 3. Información de Software Support CD

Esta placa-base soporta diversos tipos de sistema operativo Windows®: 7 / 7 64 bits / Vista™ / Vista™ 64 bits / XP / XP 64 bits. El CD de instalación que acompaña la placa-base trae todos los drivers y programas utilitarios para instalar y configurar la placa-base. Para iniciar la instalación, ponga el CD en el lector de CD y se desplegará el Menú Principal automáticamente si «AUTORUN» está habilitado en su computadora.

Si el Menú Principal no aparece automáticamente, localice y doble-pulse en el archivo "ASSETUP.EXE" para iniciar la instalación.

# 1. Введение

Благодарим вас за покупку материнской платы **Fatal1ty X79 Professional Series** надежной материнской платы, изготовленной в соответствии с постоянно предъявляемыми ASRock жесткими требованиями к качеству. Она обеспечивает превосходную производительность и отличается отличной конструкцией, которые отражают приверженность ASRock качеству и долговечности.

Данное руководство по быстрой установке включает вводную информацию о материнской плате и пошаговые инструкции по ее установке. Более подробные сведения о плате можно найти в руководстве пользователя на компакт-диске поддержки.



Спецификации материнской платы и программное обеспечение BIOS иногда изменяются, поэтому содержание этого руководства может обновляться без уведомления. В случае любых модификаций руководства его новая версия будет размещена на веб-сайте ASRock без специального уведомления. Кроме того, самые свежие списки поддерживаемых модулей памяти и процессоров можно найти на сайте ASRock.

Адрес веб-сайта ASRock <http://www.asrock.com>

При необходимости технической поддержки по вопросам данной материнской платы посетите наш веб-сайт для получения информации об используемой модели.

[www.asrock.com/support/index.asp](http://www.asrock.com/support/index.asp)

## 1.1 Комплектность

Материнская плата **Fatal1ty X79 Professional Series**

(форм-фактор ATX: 12,0 x 9,6 дюйма / 30,5 x 24,4 см)

Руководство по быстрой установке **Fatal1ty X79 Professional Series**

Компакт-диск поддержки **Fatal1ty X79 Professional Series**

6 x кабель данных Serial ATA (SATA) (дополнительно)

2 x кабель питания для жесткого диска Serial ATA (SATA) (дополнительно)

1 x I/O Щит Группы ввода / вывода

1 x Передняя панель USB 3.0

4 x корпусе Винты

6 x Жесткий диск Винты

1 x Кронштейн заднего разъема USB 3.0

2 x карта ASRock SLI\_Bridge

1 x карта ASRock SLI\_Bridge\_3S

1 x Карта ASRock 3-Way SLI Bridge



### ASRock напоминает...

Для обеспечения максимальной производительности ОС Windows® 7 / 7 64-bit / Vista™ / Vista™ 64-bit рекомендуется в BIOS выбрать для параметра Storage Configuration (Конфигурация запоминающего устройства) режим AHCI. Подробные сведения о настройке BIOS см. в руководстве пользователя на прилагаемом компакт-диске.

## 1.2 Спецификации

<b>Платформа</b>	<ul style="list-style-type: none"> <li>- форм-фактор ATX: 12,0 x 9,6 дюйма / 30,5 x 24,4 см</li> <li>- Дизайн конденсатора Premium Gold (100% японские высококачественные конденсаторы на основе проводящих полимеров)</li> </ul>
<b>Процессор</b>	<ul style="list-style-type: none"> <li>- Поддерживаются процессоры семейства Intel® Core™ i7 для разъема LGA 2011</li> <li>- Дизайн системы питания DigiPower</li> <li>- Технология Advanced 16 + 2 Power Phase Design</li> <li>- Поддержка технологии Intel® Turbo Boost 2.0</li> <li>- Поддержка технологии Hyper-Threading (см. <b>ОСТОРОЖНО, пункт 1</b>)</li> <li>- Поддержка технологии Untied Overclocking</li> </ul>
<b>Набор микросхем</b>	- Intel® X79
<b>Память</b>	<ul style="list-style-type: none"> <li>- Поддержка технологии Quad Channel DDR3 Memory Technology (см. <b>ОСТОРОЖНО, пункт 2</b>)</li> <li>- 4 x гнезда DDR3 DIMM</li> <li>- Поддержите DDR3 2400+(OC)/2133(OC)/1866(OC)/1600/1333/1066/ не- ECC, безбуферная память</li> <li>- Поддерживает DDR3 ECC, безбуферную память с процессорами Intel® Workstation 1S Xeon® серии E5 16xx/26xx/46xx с разъемом LGA 2011</li> <li>- Максимальный объем системной памяти: 32 ГБ (см. <b>ОСТОРОЖНО, пункт 3</b>)</li> <li>- поддержка профиля Intel® Extreme Memory Profile (XMP)1.3/1.2</li> </ul>
<b>Гнезда расширения</b>	<ul style="list-style-type: none"> <li>- 4 x слота PCI Express 3.0 x16 (PCIЕ1/PCIЕ2/PCIЕ4/PCIЕ5: режим x16/8/16/0; режим x16/8/8/8) (см. <b>ОСТОРОЖНО, пункт 4</b>)</li> <li>- 1 x гнезда PCI Express 2.0 x1</li> <li>- 2 x гнезда PCI</li> <li>- поддержка AMD Quad CrossFireX™, 4-Way CrossFireX™, 3-Way CrossFireX™ и CrossFireX™</li> <li>- поддержка NVIDIA® Quad SLI™, 4-Way SLI™, 3-Way SLI™ и SLI™</li> </ul>
<b>Аудиосистема</b>	<ul style="list-style-type: none"> <li>- 7.1 CH HD Аудио HD с Довольной Защитой (Кодер-декодер Аудио Realtek ALC898)</li> <li>- Поддержка Premium Blu-ray audio</li> <li>- Поддержка технологии THX TruStudio™</li> </ul>
<b>ЛВС</b>	<ul style="list-style-type: none"> <li>- PCIЕ x 1 Gigabit LAN 10/100/1000 Mb/s</li> <li>- Broadcom BCM57781</li> <li>- поддержка Wake-On-LAN</li> <li>- Поддержка энергосберегающего интерфейса Ethernet 802.3az</li> <li>- Поддержка PXE</li> </ul>
<b>Разъемы ввода-вывода на задней панели</b>	<p>I/O Panel</p> <ul style="list-style-type: none"> <li>- 1 x порт клавиатуры PS/2</li> <li>- 1 x порт Coaxial SPDIF Out</li> <li>- 1 x порт Optical SPDIF Out</li> <li>- 5 x порта USB 2.0 на задней панели в стандартной конфигурации</li> </ul>



	<ul style="list-style-type: none"> <li>- 1 x порт мыши Fatal1ty (USB 2.0)</li> <li>- 2 x eSATA3 порта</li> <li>- 4 x порта USB 3.0 на задней панели в стандартной конфигурации</li> <li>- Разъем 1 x RJ-45 LAN с светодиодным индикатором (индикатор ACT/LINK и индикатор SPEED)</li> <li>- 1 x порт IEEE 1394</li> <li>- 1 x кнопка Clear CMOS</li> <li>- Соединитель звуковой подсистемы: тыльная колонка / центральная / субвуфер / линейный вход / передняя колонка / микрофон (см. <b>ПРЕДУПРЕЖДЕНИЕ 5</b>)</li> </ul>
<b>SATA3</b>	<ul style="list-style-type: none"> <li>- 2 x порта SATA3 со скоростью передачи данных 6,0 Гбит/с от контроллера Intel® X79, с аппаратной поддержкой функций RAID (RAID 0, RAID 1, RAID 5, RAID 10 и Intel Rapid Storage3.0), NCQ, AHCI и «горячего подключения»</li> <li>- 4 x порта SATA3 со скоростью передачи данных 6,0 Гбит/с от контроллера Marvell SE9172, с аппаратной поддержкой функций RAID (RAID 0 и RAID 1), NCQ, AHCI и «горячего подключения»</li> </ul>
<b>USB 3.0</b>	<ul style="list-style-type: none"> <li>- 4 x задних порта USB 3.0 на контроллере TI®, с поддержкой интерфейсов USB 1.0/2.0/3.0 и скорости передачи данных до 5 Гбит/с</li> <li>- 2 x передний разъем USB 3.0 (поддерживает 4 порта USB 3.0) на контроллере TI®, с поддержкой интерфейсов USB 1.0/2.0/3.0 и скорости передачи данных до 5 Гбит/с</li> </ul>
<b>Колодки и плате</b>	<ul style="list-style-type: none"> <li>- 4 x разъема SATA2 3,0 Гбит/с, поддержка функций RAID (RAID 0, RAID 1, RAID 5, RAID 10 и Intel Rapid Storage3.0), NCQ, AHCI и «горячего подключения»</li> <li>- 6 x разъема SATA3 6,0 Гбит/с</li> <li>- 1 x Колодка инфракрасного модуля</li> <li>- 1 x Датчик пользовательского инфракрасного модуля</li> <li>- 1 x Колодка COM</li> <li>- 1 x Колодка HDMI_SPDIF</li> <li>- 1 x Колодка IEEE 1394</li> <li>- 1 x разъем Power LED</li> <li>- соединитель: CPU/Chassis/Power FAN</li> <li>- 24-контактный Колодка питания ATX</li> <li>- 8-контактный Разъем ATX 12 В</li> <li>- Разъем питания SLI/XFIRE</li> <li>- Аудиоразъем передней панели</li> <li>- 3 x Колодка USB 2.0 (одна колодка для поддержки 6 дополнительных портов USB 2.0)</li> <li>- 2 x Колодка USB 3.0 (одна колодка для поддержки 4 дополнительных портов USB 3.0)</li> <li>- 1 x Dr. Debug (7-сегментный ЖК-дисплей)</li> </ul>
<b>Быстрое переключение</b>	<ul style="list-style-type: none"> <li>- 1 x кнопка Power Switch со светодиодом</li> <li>- 1 x кнопка Reset Switch со светодиодом</li> <li>- 1 x кнопка Clear CMOS со светодиодом</li> </ul>
<b>BIOS</b>	<ul style="list-style-type: none"> <li>- 64Mb AMI UEFI Legal BIOS с поддержкой графического интерфейса</li> </ul>

	<ul style="list-style-type: none"> <li>пользователя</li> <li>- поддержка "Plug and Play"</li> <li>- ACPI 1.1, включение по событиям</li> <li>- поддержка режима настройки без перемычек</li> <li>- поддержка SMBIOS 2.3.1</li> <li>- Регулировка напряжений CPU, VCCSA, DRAM, VTT, CPU PLL, PCH1.1V, PCH1.5V</li> </ul>
<b>Компакт-диск поддержки</b>	- Драйверы, служебные программы, антивирусное программное обеспечение (пробная версия), Пробная версия программы CyberLink MediaEspresso 6.5, пакет программ ASRock (ASRock MAGIX Multimedia Suite - поставщик)
<b>Уникальная особенность</b>	<ul style="list-style-type: none"> <li>- F-Stream (см. <b>ОСТОРОЖНО, пункт 6</b>)</li> <li>- ASRock Instant Boot</li> <li>- ASRock Instant Flash (см. <b>ОСТОРОЖНО, пункт 7</b>)</li> <li>- ASRock APP Charger (см. <b>ОСТОРОЖНО, пункт 8</b>)</li> <li>- ASRock SmartView (см. <b>ОСТОРОЖНО, пункт 9</b>)</li> <li>- ASRock XFast USB (см. <b>ОСТОРОЖНО, пункт 10</b>)</li> <li>- ASRock XFast LAN (см. <b>ОСТОРОЖНО, пункт 11</b>)</li> <li>- Зарядное устройство ASRock XFast (см. <b>ОСТОРОЖНО, пункт 12</b>)</li> <li>- ASRock XFast RAM (см. <b>ОСТОРОЖНО, пункт 13</b>)</li> <li>- ASRock Crashless BIOS (см. <b>ОСТОРОЖНО, пункт 14</b>)</li> <li>- Hybrid Booster: <ul style="list-style-type: none"> <li>- плавная настройка частоты процессора (см. <b>ОСТОРОЖНО, пункт 15</b>)</li> <li>- ASRock U-COP (см. <b>ОСТОРОЖНО, пункт 16</b>)</li> <li>- Защита от сбоя загрузки Boot Failure Guard (B.F.G)</li> </ul> </li> <li>- Ночное LED-освещение</li> </ul>
<b>Контроль оборудования</b>	<ul style="list-style-type: none"> <li>- Датчики температуры процессора</li> <li>- Датчики температуры корпуса</li> <li>- Тахометры вентиляторов CPU/Chassis/Power FAN</li> <li>- Бесшумный вентилятор ЦП/системного блока (возможность автоматической настройки скорости вентилятора системного блока в соответствии с температурой центрального процессора)</li> <li>- Мультиконтроль скорости вентилятора ЦП/Шасси</li> <li>- Контроль= напряжения: +12V, +5V, +3.3V, Vcore</li> </ul>
<b>Операционные системы</b>	- Совместимость с Microsoft® Windows® 7 / 7 64-bit / Vista™ / Поддержка 64-разрядной версии Vista™ / XP / XP 64-bit (см. <b>ОСТОРОЖНО, пункт 17</b> )
<b>Сертификаты</b>	<ul style="list-style-type: none"> <li>- FCC, CE, WHQL</li> <li>- Совместимость с ErP/EuP Ready (требуется блок питания совместимый с ErP/EuP) (см. <b>ОСТОРОЖНО, пункт 18</b>)</li> </ul>

\* Для детальной информации продукта, пожалуйста посетите наш вебсайт:

<http://www.asrock.com>

## ВНИМАНИЕ

Следует понимать, что с оверклокингом связан определенный риск во всех случаях, включая изменение установок BIOS, применение технологии Untied Overclocking или использование инструментов оверклокинга сторонних производителей. Оверклокинг может повлиять на стабильность работы системы и даже вызвать повреждение входящих в нее компонентов и устройств. Приступая к оверклокингу, вы полностью берете на себя все связанные с ним риски и расходы. Мы не будем нести ответственность за любые возможные повреждения в результате оверклокинга.

## ОСТОРОЖНО!

1. Информацию об установке параметров гиперпоточной технологии (Hyper-Threading Technology) вы найдете на стр. 67 Руководства пользователя на компакт-диске поддержки.
2. Данная материнская плата поддерживает Технология четырехканальной памяти DDR3. Перед ее использованием не забудьте прочитать инструкции по правильной установке модулей памяти в руководстве по установке (стр. 18).
3. В силу ограничения операционной системы фактическая емкость памяти может быть меньше 4Гб для обеспечения резервного места для использования системой Windows® 7 / Vista™ / XP. Таких ограничений нет для Windows® OS с 64-bit центральным процессором. Технология ASRock XFast RAM помогает использовать память, которая не используется ОС Windows®.
4. В настоящее время процессор Intel® Socket 2011 Sandy Bridge-E не поддерживает PCIE 3.0, но данная материнская плата выпускается с поддержкой PCIE 3.0. Активация PCIE 3.0 зависит от ЦП Intel. Информацию о будущих обновлениях и выпусках ЦП см. на веб-сайте компании Intel.
5. Поддерживается работа микрофонного входа в режимах моно и стерео. Поддерживаются 2-, 4-, 6- и 8-канальный режимы вывода звука. Соответствующие схемы подключения описаны на стр. 5.
6. Служебная программа F-Stream – это универсальное средство тонкой настройки различных функций системы с удобным и понятным интерфейсом, включающая разделы Hardware Monitor (Наблюдение за оборудованием), Fan Control (Управление вентилятором), Overclocking («Разгон» процессора), OC DNA (Параметры «разгона») and IES (Автоматическое энергосбережение). В разделе Hardware Monitor (Наблюдение за оборудованием) отображаются основные характеристики аппаратных средств системы. В разделе Fan Control (Управление вентилятором) отображается скорость вентилятора и температура, которые можно регулировать. В разделе Overclocking («Разгон» процессора) можно увеличить рабочую частоту ЦПУ, чтобы добиться оптимальной производительности системы. В разделе ОС

DNA (Параметры «разгона») можно сохранить настройки «разгона» процессора в виде профиля, который потом можно предложить для использования своим друзьям. Друзья смогут загрузить профиль «разгона» на свои компьютеры и получить аналогичный результат. В разделе IES (Автоматическое энергосбережение) можно настроить регулятор напряжения так, что он будет уменьшать количество работающих линий питания, чтобы поднять КПД системы без ущерба для ее производительности во время простоя ядер ЦПУ.

7. ASRock Instant Flash – программа для прошивки BIOS, встроенная в Flash ROM. Данное средство для обновления BIOS умеет работать без входа в операционные системы, вроде MS-DOS или Windows®. Чтобы запустить программу достаточно нажать <F6> во время самотестирования системы (POST) или войти в BIOS при помощи кнопки <F2> и выбрать пункт ASRock Instant Flash через меню. Запустите программу и сохраните новый BIOS на USB-флэшку, дискету или жесткий диск. После этого вы сможете оперативно обновить BIOS, без необходимости подготовки дополнительных дискет, без установки программы прошивки. Имейте в виду, что USB-флэшка или винчестер должны использовать файловую систему FAT32/16/12.
8. Если вы хотите быстрее и без ограничений заряжать свои устройства Apple, например iPhone, iPad и iPod Touch, компания ASRock приготовила отличное решение для вас – ASRock APP Charger. Просто установив драйвер APP Charger, вы сможете заряжать iPhone от компьютера намного быстрее, ускорение составит до 40%. ASRock APP Charger позволяет быстро заряжать несколько устройств Apple одновременно и даже поддерживает непрерывную зарядку, когда компьютер переходит в режим ожидания (S1), режим ожидания с сохранением данных в ОЗУ (S3), режим гибернации (S4) или режим выключения (S5). Установив драйвер APP Charger, вы испытаете небывалое удобство зарядки.  
Веб-сайт ASRock: <http://www.asrock.com/Feature/AppCharger/index.asp>
9. SmartView — это интеллектуальная стартовая страница для браузера IE, на которой отображаются наиболее посещаемые веб-сайты, история посещений, друзья в Facebook и обновляемые потоки новостей. Эта новая функция обеспечивает более удобное использование возможностей Интернета. Системные платы ASRock эксклюзивно снабжаются программой SmartView, помогающей поддерживать связь с друзьями. Программа SmartView работает в ОС Windows® 7 / 7 64 bit / Vista™ / Vista™ 64 bit и браузере IE8. Веб-сайт ASRock: <http://www.asrock.com/Feature/SmartView/index.asp>
10. Функция ASRock XFast USB увеличивает скорость работы устройств USB. Рост скорости зависит от устройства.
11. ASRock XFast LAN обеспечивает более быстрый доступ к сети Интернет, который даст описанные далее преимущества. Установка приоритетов приложений ЛВС: можно задать оптимальный приоритет для своего приложения и/или добавить новые программы. Более низкая латентность

в игре: после установки более высокого приоритета игре в режиме онлайн, может снизиться латентность в игре. Формирование трафика: можно одновременно просматривать видео высокого разрешения на Youtube и загружать файлы. Анализ данных в реальном времени: в окне состояния можно легко определить, какие потоки данных передаются в данный момент времени.

12. Зарядное устройство ASRock XFast - оптимальное и самое быстрое действующее решение для зарядки мобильных устройств через ПК. Благодаря превосходному USB порту зарядного устройства XFast, пользователи уверены в том, что в любое время смогут быстро зарядить необходимые устройства. Помимо устройств Apple, его можно использовать для зарядки стандартных интеллектуальных устройств ВС 1.1. Подробная информация представлена на стр. 35.
13. ASRock XFast RAM – новая функция, входящая в состав утилиты F-Stream. Благодаря ей, используется область памяти, использование которой не возможно на процессоре с 32-битной ОС Windows®. ASRock XFast RAM сокращает время загрузки истории посещения веб-сайтов, существенно ускоряя навигацию по сети Интернет. Кроме того, скорость работы Adobe Photoshop 5 увеличивается в пять раз. В числе преимуществ ASRock XFast RAM - сокращение частоты обращений к SSD-накопителям и жестким дискам и продление срока их эксплуатации.
14. ASRock Crashless BIOS позволяет пользователям обновлять BIOS, не боясь отказа. В случае отключения электроэнергии в процессе обновления BIOS ASRock Crashless BIOS автоматически завершает процедуру обновления BIOS после возобновления подачи энергии. Обратите внимание на то, что BIOS размещается в корневом каталоге вашего USB диска. Данная функция доступна только для портов USB2.0.
15. Хотя данная материнская плата поддерживает плавную настройку частоты, устанавливать повышенную частоту не рекомендуется. Использование значений частоты шины процессора отличающихся от рекомендованных, может привести к нестабильной работе системы или повреждению процессора и материнской платы.
16. При обнаружении перегрева процессора работа системы автоматически завершается. Прежде чем возобновить работу системы, убедитесь в нормальной работе вентилятора процессора на материнской плате и отсоедините шнур питания, а затем снова подключите его. Чтобы улучшить отвод тепла, не забудьте при сборке компьютера нанести термопасту между процессором и радиатором.
17. ОС Microsoft® Windows® XP / XP 64-разрядной версией, не поддерживает Intel Rapid Storage Technology enterprise 3.0 и ASRock XFast RAM.
18. EuP расшифровывается как Energy Using Product. Стандарт был разработан Европейским Союзом для определения энергопотребления готовых систем. По требованию EuP система в выключенном состоянии должна потреблять менее 1 Вт энергии. Для соответствия стандарту EuP нужны соответствующие материнская плата и блок питания. Компания

---

Intel предложила, что совместимый с EuP блок питания должен обеспечивать 50% эффективность линии питания 5V при потреблении 100 мА (в режиме ожидания). Сверьтесь с информацией производителей блоков питания, чтобы выбрать модель с поддержкой EuP.

### 1.3 Установка перемычек

Конфигурация перемычек иллюстрируется на рисунке. Когда перемычка надета на контакты, они называются “замкнутыми” (short). Если на контактах перемычки нет, то они называются “разомкнутыми” (open). На иллюстрации показана 3-контактная перемычка, у которой контакты 1 и 2 замкнуты.



Перемычка	Установка	Описание
Очистка CMOS (CLRCMOS1, 3-контактная перемычка) (см. стр. 4, п. 25)	 Стандартные	 Очистка CMOS

**Примечание.** Контактная колодка CLRCMOS1 позволяет очистить данные CMOS. Для очистки данных и восстановления заводских системных параметров сначала выключите компьютер и отсоедините сетевую вилку кабеля питания от электророзетки. Выждите не менее 15 секунд и колпачковой перемычкой на 5 секунд перемкните штырьки 2 и 3 контактной колодки CLRCMOS1. Однако не производите очистку CMOS непосредственно после обновления BIOS. Если необходимо очистить CMOS сразу же после окончания обновления BIOS, то, перед очисткой CMOS, необходимо сначала выполнить загрузку системы, а затем завершить ее работу. Примите во внимание, что пароль, дата, время, профиль пользователя по умолчанию, идентификатор 1394 GUID и MAC-адрес будут очищены только тогда, когда будет извлечена из своего гнезда батарейка CMOS.



Переключатель Clear CMOS работает так же, как перемычка Clear CMOS.

## 1.4 Колодки и разъемы на плате



Имеющиеся на плате колодки и разъемы НЕ ЯВЛЯЮТСЯ контактами для перемычек. НЕ УСТАНАВЛИВАЙТЕ перемычки на эти колодки и разъемы – это приведет к необратимому повреждению материнской платы!

### Разъемы Serial ATA2

(SATA2\_0\_1, см. стр. 4, п. 13)

(SATA2\_2\_3, см. стр. 4, п. 12)

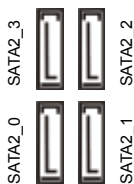

четыре соединителя Serial ATA2 предназначены для подключения внутренних устройств хранения с использованием интерфейсных кабелей SATA2. В настоящее время интерфейс SATA допускает скорость передачи данных до \ 3,0 Гбит/с.

### Разъемы Serial ATA3

(SATA3\_0\_1, см. стр. 4, п. 14)

(SATA3\_M0\_M1, см. стр. 4, п. 15)

(SATA3\_M2\_M3, см. стр. 4, п. 16)

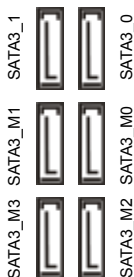

шесть соединителя Serial ATA3 предназначены для подключения внутренних устройств хранения с использованием интерфейсных кабелей SATA3. В настоящее время интерфейс SATA допускает скорость передачи данных до \ 6,0 Гбит/с.

Информационный кабель Serial ATA (SATA)  
(дополнительно)



Информационный кабель интерфейса SATA / SATA2 / SATA3 не является направленным. Любой из его соединителей может быть подключен либо к жесткому диску интерфейса SATA2 / SATA3 либо к материнской плате.

Кабель питания Serial ATA (SATA)  
(дополнительно)

↑  
подключите к соединителю питания жесткого диска интерфейса SATA

↑  
подключите к источнику питания

Присоедините кабель питания стандарта SATA с помощью соединителей на его черном конце с ответными соединителями питания на каждом из жестких дисков. Затем соедините белый конец кабеля питания стандарта.



Колодка USB 2.0  
(9-контактный USB\_6\_7)  
(см. стр. 4, п. 29)

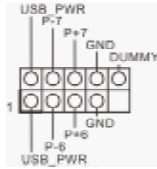

(9-контактный USB\_8\_9)  
(см. стр. 4, п. 28)

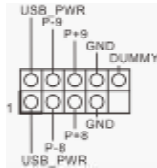

(9-контактный USB\_10\_11)  
(см. стр. 4, п. 27)

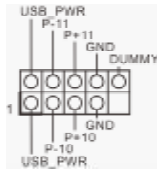

Помимо шести стандартных портов USB 2.0 на панели ввода-вывода, на данной материнской плате предусмотрено три разъема USB 2.0. Каждый разъем USB 2.0 поддерживает два порта USB 2.0.

Колодка USB 3.0  
(19-контактный USB3\_5\_6)  
(см. стр. 4, п. 8)

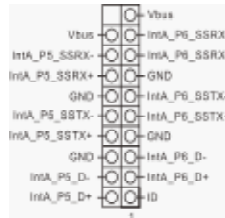

Помимо четырех стандартных портов USB 3.0 на панели ввода-вывода, на данной материнской плате предусмотрен два разъема USB 3.0. Каждый разъем USB 3.0 поддерживает два порта USB 3.0.

(19-контактный USB3\_7\_8)  
(см. стр. 4, п. 9)

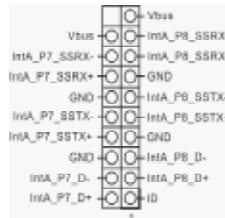

Колодка инфракрасного модуля  
(5-контактный IR1)  
(см. стр. 4, п. 37)

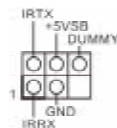

Данная колодка позволяет подключить дополнительный модуль беспроводного инфракрасного приемопередатчика.

Датчик пользовательского инфракрасного модуля  
(4-контактный CIR1)  
(см. стр. 4, п. 30)



Датчик можно использовать для подключения дополнительных пользовательских инфракрасных устройств, например, устройств HI-FI, телевизоров и т.д.

Аудиоразъем передней панели  
(9-контактный HD\_AUDIO1)  
(см. стр. 4, п. 35)

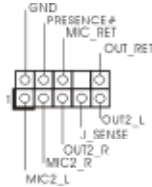

Этот интерфейс предназначен для присоединения аудиокабеля передней панели, обеспечивающего удобное подключение аудиоустройств и управление ими.



1. Система High Definition Audio поддерживает функцию автоматического обнаружения разъемов (Jack Sensing), однако для ее правильной работы кабель панели в корпусе должен поддерживать HDA. При сборке системы следуйте инструкциям, приведенным в нашем руководстве и руководстве пользователя для корпуса.
2. Если вы используете аудиопанель AC'97, подключите ее к колодке аудиоинтерфейса передней панели следующим образом:
  - A. Подключите выводы Mic\_IN (MIC) к контактам MIC2\_L.
  - B. Подключите выводы Audio\_R (RIN) к контактам OUT2\_R, а выводы Audio\_L (LIN) к контактам OUT2\_L.
  - C. Подключите выводы Ground (GND) к контактам Ground (GND).
  - D. Контакты MIC\_RET и OUT\_RET предназначены только для аудиопанели HD. При использовании аудиопанели AC'97 подключать их не нужно.
  - E. Процедура активации микрофона приведена ниже.  
Для ОС Windows® XP / XP 64-бита:  
Выберите «Mixer» (Микшер). Выберите «Recorder» (Устройство записи). Затем щелкните «FrontMic» (Передний микрофон).  
Для ОС Windows® 7 / 7 64-бита, Vista™ / Vista™ 64-бита:  
Перейдите в вкладке «FrontMic» (Передний микрофон) в панели управления Realtek. Отрегулируйте уровень «Recording Volume» (Громкость записи).

Колодка системной панели  
(9-контактный PANEL1)  
(см. стр. 4, п. 22)

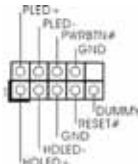

Данная колодка обеспечивает работу нескольких функций передней панели системы.



Подключите к этому разъему кнопку питания, кнопку сброса и индикатор состояния системы на корпусе в соответствии с указанным ниже назначением контактов. При подключении кабелей необходимо соблюдать полярность положительных и отрицательных контактов.

**PWRBTN (кнопка питания):**

Подключите к этим контактам кнопку питания на передней панели корпуса. Способ выключения системы с помощью кнопки питания можно настроить.

**RESET (кнопка сброса):**

Подключите к этим контактам кнопку сброса на передней панели корпуса. Нажмите кнопку сброса для перезагрузки компьютера, если компьютер «завис» и нормальную перезагрузку выполнить не удастся.

**PLED (индикатор питания системы):**

Подключите к этим контактам индикатор состояния питания на передней панели корпуса. Этот индикатор светится, когда система работает. Индикатор мигает, когда система находится в режиме ожидания S1. Этот индикатор не светится, когда система находится в режиме ожидания S3 или S4, либо выключена (S5).

**HDLED (индикатор активности жесткого диска):**

Подключите к этим контактам индикатор активности жесткого диска на передней панели корпуса. Этот индикатор светится, когда осуществляется считывание или запись данных на жестком диске.

Конструкция передней панели может различаться в зависимости от корпуса. Модуль передней панели в основном состоит из кнопки питания, кнопки сброса, индикатора питания, индикатора активности жесткого диска, динамика и т.п. При подключении к этому разъему модуля передней панели корпуса удостоверьтесь, что провода подключаются к соответствующим контактам.

Колодка динамика корпуса  
(4-контактный SPEAKER1)  
(см. стр. 4, п. 21)

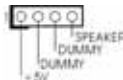

Подключите к этой колодке кабель от динамика на корпусе компьютера.

разъем Power LED  
(3-контактный PLED1)  
(см. стр. 4, п. 23)



Подключите индикатор Power LED к этому разъему для отображения статуса питания системы. Этот светодиод продолжит мигать в режиме S1. Светодиод будет выключен в режимах S3/S4 или S5 (система выключена).

### Chassis, Power и SB Fan-соединители

(4-контактный CHA\_FAN1)

(см. стр. 4, п. 11)

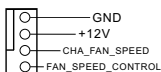

(3-контактный CHA\_FAN2)

(см. стр. 4, п. 20)

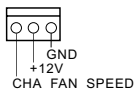

(3-контактный CHA\_FAN3)

(см. стр. 4, п. 17)

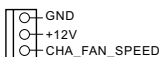

(3-контактный PWR\_FAN1)

(см. стр. 4, п. 44)

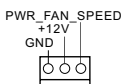

Подключите кабели вентилятора к соединителям и присоедините черный шнур к штырю заземления. CHA\_FAN1, CHA\_FAN2 и CHA\_FAN3 поддерживают функцию управления вентилятором.

### Разъем вентилятора процессора

(4-контактный CPU\_FAN1)

(см. стр. 4, п. 5)

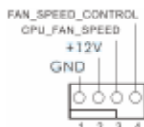

Подключите к этому разъему кабель вентилятора процессора так, чтобы черный провод соответствовал контакту земли.



Данная материнская плата поддерживает вентиляторы процессора с 4-контактным разъемом (функция тихого режима вентилятора), однако вентиляторы с 3-контактным разъемом также будут успешно работать, хотя функция управления скоростью вращения вентилятора окажется недоступной. Если вы хотите подключить вентилятор процессора с 3-контактным разъемом к разъему вентилятора процессора на данной материнской плате, для этого следует использовать контакты 1-3.

**Контакты 1-3 подключены** ←

Установка вентилятора с 3-контактным разъемом

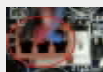

(4-контактный CPU\_FAN2)

(см. стр. 4, п. 6)

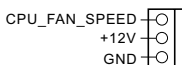

### Колодка питания ATX

(24-контактный ATXPWR1)

(см. стр. 4, п. 7)

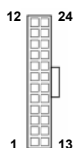

Подключите к этой колодке кабель питания ATX.



Несмотря на то, что эта материнская плата предусматривает 24-штыревой разъем питания ATX, работа будет продолжаться, даже если адаптируется традиционный 20-штыревой разъем питания ATX. Для использования 20-штыревого разъема питания ATX вставьте источник питания вместе со штекером 1 и штекером 13.

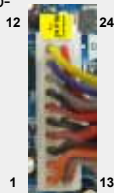

Установка 20-штыревого разъема питания ATX 1

#### Колодка питания 12V-ATX

(8-контактный ATX12V1)

(см. стр. 4, п. 3)

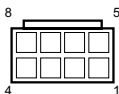

Подключите к этой колодке

кабель питания ATX 12V.



Хотя эта объединительная плата обеспечивает ATX с 8 булавками 12V соединитель власти, это может все еще работать, если Вы принимаете традиционный ATX с 4-Pin 12V электропитание. Чтобы использовать электропитание ATX с 4-Pin, пожалуйста включите ваше электропитание наряду с Булавкой 1 и Прикрепите 5.



ATX C 4-Pin 12V Установка Электропитания

#### Разъем питания SLI/XFIRE

(4-контактный SLI/XFIRE\_POWER1)

(см. стр.4, п. 31)



SLI/XFIRE\_POWER1

Данный разъем использовать не

обязательно, но его следует

подключить к разъему питания жесткого диска, если в системную плату одновременно установлены две видеокарты.

#### Колодки IEEE 1394

(9-контактный FRONT\_1394)

(см. стр. 4, п. 34)

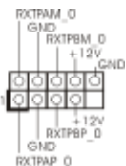

Помимо четырех портов IEEE 1394 на панели ввода-вывода имеются две группы контактов на материнской плате для подключения двух дополнительных портов IEEE 1394 каждая.

#### Колодка COM-порта

(9-контактный COM1)

(см. стр. 4, п. 32)

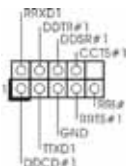

Данная колодка COM-порта позволяет подключить модуль порта COM.

---

Колодка HDMI\_SPDIF  
(2-контактный HDMI\_SPDIF1)  
(см. стр. 4, п. 33)



Колодка HDMI\_SPDIF обеспечивает подачу выходного аудиосигнала на VGA-карту HDMI, что позволяет подключать к системе цифровые телевизоры, проекторы или жидкокристаллические панели HDMI. Соедините эту колодку с разъемом HDMI\_SPDIF на VGA-карте HDMI.

## Руководство по установке передней панели USB 3.0

**Шаг 1** Подготовьте комплект передней панели USB 3.0, четыре винта для крепления жесткого диска и шесть винтов для крепления к шасси.



**Шаг 3** Установите переднюю панель USB 3.0 в отсек 2,5"-накопителя на шасси.



**Шаг 5** Подключите кабель передней панели USB 3.0 к монтажной колодке порта USB 3.0 (USB3\_5\_6 или USB3\_7\_8) на материнской плате.



**Шаг 2** Закрепите 2,5"-привод жесткого/твердотельного диска на передней панели USB 3.0 с помощью четырех винтов.



**Шаг 4** Закрепите переднюю панель USB 3.0 в отсеке накопителя с помощью шести винтов.



**Шаг 6** Передняя панель USB 3.0 готова к использованию.



## Руководство по установке кронштейна заднего разъема USB 3.0

**Шаг 1** Открутите два винта на передней панели USB 3.0.



**Шаг 3** Закрутите два винта кронштейна заднего разъема USB 3.0.



**Шаг 2** Соедините кабель USB 3.0 и кронштейн разъема USB 3.0.



**Шаг 4** Вставьте кронштейн заднего разъема USB 3.0 в корпус.



---

## 1.5 Быстрое переключение

На этой материнской плате есть три кнопки для ускорения работы: кнопка питания, кнопка перезагрузки и кнопка для очистки CMOS, которые позволяют пользователям быстро включить/выключить или перезагрузить компьютер, сбросить установки CMOS, соответственно.

---

Power Switch  
(PWRBTN)  
(см. стр. 4, п. 18)



Кнопка Power Switch позволяет быстро включить или выключить систему.

---

Reset Switch  
(RSTBTN)  
(см. стр. 4, п. 19)



Кнопка Reset Switch позволяет быстро перезагрузить систему.

---

Clear CMOS Switch  
(CLRBTN)  
(см. стр. 5, п. 18)



Кнопка Clear CMOS Switch позволяет быстро сбросить установки CMOS.



---

## 2. Информация о BIOS

Утилита настройки BIOS (BIOS Setup) хранится во флэш-памяти на материнской плате. Чтобы войти в программу настройки BIOS Setup, при запуске компьютера нажмите <F2> или <Del> во время самопроверки при включении питания (Power-On-Self-Test – POST). Если этого не сделать, то процедуры тестирования POST будут продолжаться обычным образом. Если вы захотите вызвать BIOS Setup уже после POST, перезапустите систему с помощью клавиш <Ctrl> + <Alt> + <Delete> или нажатия кнопки сброса на корпусе системы. Подробную информацию о программе BIOS Setup вы найдете в Руководстве пользователя (в формате PDF) на компакт-диске поддержки.

## 3. Информация о компакт-диске поддержки с программным обеспечением

Данная материнская плата поддерживает различные операционные системы Microsoft® Windows®: 7 / 7 64-bit / Vista™ / Vista™ 64-bit / XP / XP 64-bit. Поставляемый вместе с ней компакт-диск поддержки содержит необходимые драйверы и полезные утилиты, которые расширяют возможности материнской платы.

Чтобы начать работу с компакт-диском поддержки, вставьте его в дисковод CD-ROM. Если в вашем компьютере включена функция автозапуска (AUTORUN), то на экране автоматически появится главное меню компакт-диска (Main Menu). Если этого не произошло, найдите в папке BIN на компакт-диске поддержки файл ASSETUP.EXE и дважды щелкните на нем, чтобы открыть меню.

# 1. Giriş

ASRock'ın kesintisiz titiz kalite denetimi altında üretilen güvenilir bir anakart olan **Fatal1ty X79 Professional Series** anakartını satın aldığınız için teşekkür ederiz. ASRock'ın kalite ve dayanıklılık konusundaki kararlılığına uygun güçlü tasarımıyla mükemmel bir performans sunar.

Bu Hızlı Takma Kılavuzu anakarta giriş ve adım adım takma kılavuzu içerir. Anakart hakkında daha ayrıntılı bilgiyi Destek CD'sinde sunulan kullanıcı kılavuzunda bulabilirsiniz.



Anakart özellikleri ve BIOS yazılımı güncelleştirilebileceğinden bu kılavuzun içeriği önceden haber verilmeksizin değişebilir. Bu belgede değişiklik yapılması durumunda, güncelleştirilmiş sürüm ayrıca haber verilmeksizin ASRock web sitesinde sunulur. En son VGA kartlarını ve CPU destek listelerini de ASRock web sitesinde bulabilirsiniz. ASRock web sitesi <http://www.asrock.com>  
Bu anakartla ilgili teknik desteğe ihtiyacınız olursa, kullandığınız modele özel bilgiler için lütfen web sitemizi ziyaret edin.  
[www.asrock.com/support/index.asp](http://www.asrock.com/support/index.asp)

## 1.1 Paket İçindekiler

**Fatal1ty X79 Professional Series** Anakart

(ATX Form Faktörü: 12,0-inç x 9,6-inç, 30,5 cm x 24,4 cm)

**Fatal1ty X79 Professional Series** Hızlı Takma Kılavuzu

**Fatal1ty X79 Professional Series** Destek CD'si

6 x Seri ATA (SATA) Veri Kablosu (İsteğe Bağlı)

2 x Seri ATA (SATA) HDD Güç Kablosu (İsteğe Bağlı)

1 x G/Ç Panel Kalkanı

1 x USB 3.0 Ön Panel

4 x HDD Vida

6 x kasaya Vida

1 x Arka USB 3.0 Braketi

2 x ASRock SLI\_Bridge Kartı

1 x ASRock SLI\_Bridge\_3S Kartı

1 x ASRock 3-Yollu SLI Köprü Kartı



### **ASRock Size Şunu Hatırlatr...**

Windows® 7 / 7 64-bit / Vista™ / Vista™ 64-bit ile daha iyi performans elde etmek için, Depolama Konfigürasyonundaki BIOS seçeneğini AHCI moduna ayarlamanız tavsiye edilir. BIOS ayarı için, ayrıntıları öğrenmek üzere lütfen destek CD'mizdeki "Kullanıcı Kılavuzu"na bakın.

## 1.2 Özellikler

<b>Platform</b>	- ATX Form Faktörü: 12,0-inç x 9,6-inç, 30,5 cm x 24,4 cm - Birinci Sınıf Altın Kapasitör tasarımı (%100 Japon malı yüksek kaliteli İletken Polimer Kapasitörler)
<b>CPU</b>	- LGA 2011 soketi için Intel® Core™ i7 işlemci ailesini destekler - Digi Güç Tasarımı - Gelişmiş 16 + 2 Güç Fazı Tasarımı - Intel® Turbo Boost 2.0 Teknolojisini destekler - Hyper-Threading Teknolojisini destekler (bkz. <b>DİKKAT 1</b> ) - Untied Overclocking Teknolojisini destekler
<b>Yonga seti</b>	- Intel® X79
<b>Bellek</b>	- Dört Kanallı DDR3 Bellek Teknolojisi (bkz. <b>DİKKAT 2</b> ) - 4 x DDR3 DIMM yuva - DDR3 2400+(OC)/2133(OC)/1866(OC)/1600/1333/1066 ECC olmayan, ara belleksiz bellek - Ara bellek kullanmayan DDR3 ECC'yi, socket LGA 2011 üzerindeki Intel® Workstation 1S Xeon® işlemcileri E5 16xx/26xx/46xx serileri ile birlikte destekler - Sistem belleğinin maks. kapasitesi: 32 GB (bkz. <b>DİKKAT 3</b> ) - Intel® Extreme Bellek Profilini (XMP)1.3/1.2 destekler
<b>Genişletme Yuvası</b>	- 4 x PCI Express 3.0 x16 yuva (PCIe1/PCIe2/PCIe4/PCIe5: x16/8/16/0 modu; x16/8/8/8 modu) (bkz. <b>DİKKAT 4</b> ) - 1 x PCI Express 2.0 x1 yuva - 2 x PCI yuva - AMD Quad CrossFireX™, 4-Way CrossFireX™, 3-Way CrossFireX™ ve CrossFireX™i destekler - NVIDIA® Quad SLI™, 4-Way SLI™, 3-Way SLI™ ve SLI™'yi destekler
<b>Ses</b>	- İçerik Korumalı (Realtek ALC898 Ses Codec'i) 7,1 Kanal HD Ses - Premium Blu-ray ses desteği - THX TruStudio™ desteği
<b>LAN</b>	- PCIe x1 Gigabit LAN 10/100/1000 Mb/sn - Broadcom BCM57781 - LAN'da Uyan özelliğini destekler - Enerji Verimli Ethernet 802.3az desteği - PXE'yi destekler
<b>Arka Panel G/3</b>	G/3 Paneli - 1 x PS/2 Klavye Portu - 1 x Koaksiyel SPDIF Çıkışı Portu

	<ul style="list-style-type: none"> <li>- 1 x Optik SPDIF 3экюә Portu</li> <li>- 5 x Kullanəma Hazər USB 2.0 Portu</li> <li>- 1 x Fatal1ty Fare Portu (USB 2.0)</li> <li>- 2 x eSATA3 konektör</li> <li>- 4 x Kullanəma Hazər USB 3.0 Portu</li> <li>- 1 x RJ-45 LAN Portu, LED'li (AKT/LƏNK LED'i ve HIZ LED'i)</li> <li>- 1 x IEEE 1394 Konektörü</li> <li>- 1 x CMOS'u Temizleme Anahtarı</li> <li>- HD Ses Jakı: Yan Hoparlör/Arka Hoparlör/Orta/Bas/Hat Giriş/Ön Hoparlör/Mikrofon (bkz. <b>DİKKAT 5</b>)</li> </ul>
<b>SATA3</b>	<ul style="list-style-type: none"> <li>- 2 x SATA3 6,0Gb/sn Intel® X79 konektör, donanım RAID (RAID 0, RAID 1, RAID 5, RAID 10 ve Intel Rapid Storage3.0), NCQ, AHCI ve "Sistem Açıkken Bileşen Takma" işlevlerini</li> <li>- 4 x SATA3 6,0Gb/sn Marvell SE9172 konektör, donanım RAID (RAID 0, RAID 1), NCQ, AHCI ve "Sistem Açıkken Bileşen Takma" işlevlerini</li> </ul>
<b>USB 3.0</b>	<ul style="list-style-type: none"> <li>- TI® tarafından 4 x Arka USB 3.0 bağlantı noktası, 5Gb/s'ye kadar USB 1.0/2.0/3.0</li> <li>- TI® tarafından 2 x Ön USB 3.0 bağlantısı (2 USB 3.0 bağlantı noktasını destekler), 5Gb/s'ye kadar USB 1.0/2.0/3.0</li> </ul>
<b>Konektör</b>	<ul style="list-style-type: none"> <li>- 4 x SATA2 3,0Gb/sn, donanım RAID (RAID 0, RAID 1, RAID 5, RAID 10 ve Intel Rapid Storage3.0), NCQ, AHCI ve "Sistem Açıkken Bileşen Takma" işlevlerini</li> <li>- 6 x SATA3 6.0 Gb/sn konektör</li> <li>- 1 x KÖ fişi</li> <li>- 1 x Kullanıcı Kızılötesi Modül Bağlantısı</li> <li>- 1 x COM portu fişi</li> <li>- 1 x HDMI_SPDIF fişi</li> <li>- 1 x IEEE 1394 fişi</li> <li>- 1 x Güç LED'i fişi</li> <li>- CPU/Kasa/Güç FAN konektörü</li> <li>- 24 pin ATX güç konektörü</li> <li>- 8 pin 12V güç konektörü</li> <li>- SLI/XFire güç konektörü</li> <li>- Ön panel ses konektörü</li> <li>- 3 x USB 2.0 fiş (6 USB 2.0 portu destekler)</li> <li>- 2 x USB 3.0 fiş (4 USB 3.0 portu destekler)</li> <li>- 1 x Dr. Debug (7 Segmentli Hata Ayıklama LED'i)</li> </ul>
<b>Akıllı Anahtar</b>	<ul style="list-style-type: none"> <li>- 1 x LED'li Güç Anahtarı</li> <li>- 1 x LED'li Sıfırlama Anahtarı</li> <li>- 1 x LED'li CMOS'u Temizleme Anahtarı</li> </ul>

<b>BIOS Özelliği</b>	<ul style="list-style-type: none"> <li>- 64 Mb GUI destekli AMI UEFI Geçerli BIOS</li> <li>- "Tak Çalıştır"ı destekler</li> <li>- ACPI 1.1 Uyumlu Uyandırma Olayları</li> <li>- Jumpersiz ayarlamayı destekler</li> <li>- SMBIOS 2.3.1 Desteği</li> <li>- CPU, VCCSA, DRAM, VTT, CPU PLL, PCH1.1V, PCH1.5V Voltaj Çoklu ayarı</li> </ul>
<b>Destek CD'si</b>	<ul style="list-style-type: none"> <li>- Sürücüler, Yardımcı Programlar, AntiVirüs Yazılımı (Deneme Sürümü), CyberLink MediaEspresso 6.5 Deneme Sürümü, ASRock Yazılım Paketi (ASRock MAGIX Multimedya Seti - OEM)</li> </ul>
<b>Benzersiz Özellik</b>	<ul style="list-style-type: none"> <li>- F-Stream (bkz. <b>DİKKAT 6</b>)</li> <li>- ASRock Anında Önyükleme</li> <li>- ASRock Anında Flash (bkz. <b>DİKKAT 7</b>)</li> <li>- ASRock APP Charger (bkz. <b>DİKKAT 8</b>)</li> <li>- ASRock SmartView (bkz. <b>DİKKAT 9</b>)</li> <li>- ASRock XFast USB (bkz. <b>DİKKAT 10</b>)</li> <li>- ASRock XFast LAN (bkz. <b>DİKKAT 11</b>)</li> <li>- ASRock XFast Şarj Aleti (bkz. <b>DİKKAT 12</b>)</li> <li>- ASRock XFast RAM (bkz. <b>DİKKAT 13</b>)</li> <li>- ASRock Crashless BIOS (bkz. <b>DİKKAT 14</b>)</li> <li>- Hibrit Yükseltici: <ul style="list-style-type: none"> <li>- CPU Frekans Adımsız Kontrol (bkz. <b>DİKKAT 15</b>)</li> <li>- ASRock U-COP (bkz. <b>DİKKAT 16</b>)</li> <li>- Önyükleme Hatası Koruması (B.F.G.)</li> </ul> </li> <li>- İyi Geceler LED'i</li> </ul>
<b>Donanım Monitör</b>	<ul style="list-style-type: none"> <li>- CPU Sıcaklık Duyarlılığı</li> <li>- Kasa Sıcaklık Duyarlılığı</li> <li>- CPU/Kasa/Güç Fan Takometresi</li> <li>- İşlemci/Kasa Sessiz Fanı (Kasa Fan Hızı'nın İşlemci sıcaklığı ile Otomatik Ayar'ına izin verir)</li> <li>- CPU/Kasa Fan Çoklu-Hız Kontrolü</li> <li>- Voltaj İzleme: +12V, +5V, +3,3V, CPU Vcore</li> </ul>
<b>İS</b>	<ul style="list-style-type: none"> <li>- Microsoft® Windows® 7 / 7 64-bit / Vista™ / Vista™ 64-bit / XP / XP 64-bit uyumlu (bkz. <b>DİKKAT 17</b>)</li> </ul>
<b>Sertifikalar</b>	<ul style="list-style-type: none"> <li>- FCC, CE, WHQL</li> <li>- ErP/EuP Hazır (ErP/EuP hazır güç kaynağı gerekli) (bkz. <b>DİKKAT 18</b>)</li> </ul>

\* Ayrıntılı ürün bilgileri için lütfen web sitemizi ziyaret edin: <http://www.asrock.com>

## UYARI

Lütfen, ayarı BIOS'da ayarlama, Untied Overclocking Teknolojisi'ni uygulama veya üçüncü taraf aşırı hızlandırma araçlarını kullanma gibi durumlarda aşırı hızlandırma ile ilgili risk olduğunu unutmayın. Aşırı hızlandırma sisteminizin kararlılığını etkiler veya hatta sisteminizin bileşenlerini ve cihazlarına zarar verebilir. Bu risk size aittir ve zararı siz ödersiniz. Aşırı hızlandırmadan kaynaklanan olası zarardan sorumlu değiliz.

## DİKKAT!

1. "Hyper Threading Teknolojisi" ayarı hakkında lütfen destek CD'sindeki "Kullanıcı Kılavuzu"nda sayfa 67'ye bakın.
2. Bu anakart Çift Kanallı Bellek Teknolojisi'ni destekler. Çift Kanallı Bellek Teknolojisi'ni uygulamadan önce, uygun yükleme hakkında sayfa 18'teki bellek modüllerinin yükleme kılavuzunu okuduğunuzdan emin olun.
3. İşletim sistemi kısıtlaması nedeniyle, Windows® 7 / Vista™ / XP altında sistem kullanımı için ayırmak için gerçek bellek boyutu 4 GB'den az olabilir. 64-bit CPU'lu Windows® OS için bu tür bir sınırlama yoktur. Windows®'un kullanmadığı bellekten yararlanmak için ASRock XFast RAM'i kullanabilirsiniz.
4. Şu anda Intel® Socket 2011 Sandy Bridge-E İşlemci PCIE 3.0'ı desteklememektedir, ancak bu ana kart halihazırda PCIE 3.0 donanımı hazır tiptedir. PCIE 3.0'ı kullanımı Intel işlemcisine bağlıdır. Gelecekteki İşlemci güncellemeleri ve yeni sürümleri hakkında bilgi için, lütfen Intel'in websitesine gözatın.
5. Mikrofon çıkışı için, bu anakart hem stereo hem de mono modların destekler. Ses çıkışı için, bu anakart 2 kanallı, 4 kanallı, 6 kanallı ve 8 kanallı modları destekler. Düzgün bağlantı için sayfa 5'teki tabloyu kontrol edin.
6. F-Stream ist ein Alles-in-einem-Werkzeug zur Feineinstellung verschiedener Systemfunktionen an einer benutzerfreundlichen Schnittstelle; diese beinhaltet Hardware-Überwachung, Lüftersteuerung, Übertaktung, OC DNA und IES. Über die Hardware-Überwachung können Sie die Hauptsystemdaten einsehen. Die Lüftersteuerung zeigt Ihnen zur Anpassung Lüftergeschwindigkeit und Temperatur an. Bei der Übertaktung können Sie die CPU-Frequenz zur Erzielung optimaler Systemleistung übertakten. OC DNA ermöglicht Ihnen die Speicherung Ihrer OC-Einstellungen als Profil, welches Sie mit Freunden teilen können. Ihre Freunde können das OC-Profil dann in ihrem System laden und so die gleichen OC-Einstellungen erzielen. Per IES (Intelligent Energy Saver) kann der Spannungsregulator bei Inaktivität der CPU-Kerne die Anzahl an Ausgangsphasen zur Steigerung der Effizienz reduzieren – ohne die Rechenleistung zu beeinträchtigen.
7. ASRock Anında Flash, Flash ROM'a katıştırılmış bir BIOS flash yardımcı programıdır. Bu kullanışlı BIOS güncelleme aracı, sistem BIOS'unu MS-DOS veya Windows® gibi ilk önce işletim sistemine girmeden güncelle

menizi sağlar. Bu yardımcı programla, POST sırasında <F6> tuşuna basabilirsiniz veya BIOS ayarları menüsünün ASRock Anında Flash'a erişmesi için <F2> tuşuna basabilirsiniz. Bu aracı başlatın ve yeni BIOS dosyasını USB flash sürücünüze, diskete veya sabit sürücüye kaydedin, sonra BIOS'unuzu yalnızca birkaç tıklama ile ek bir disket veya diğer karmaşık flash yardımcı programlarını hazırlamadan güncelleyebilirsiniz. Lütfen USB flash sürücünün veya sabit diskin FAT32/16/12 dosya sistemi kullanması gerektiğini unutmayın.

8. iPhone/iPad/iPod Touch gibi Apple cihazlarınızı şarj etmek için daha hızlı ve daha özgür bir biçimde şarj etmek istiyorsanız, ASRock sizin için mükemmel bir çözüm hazırladı - ASRock APP Charger. Sadece APP Charger sürücünü kurarak, iPhone'unuzu bilgisayarınızdan daha çabuk ve eskisinden 40% daha hızlı şekilde şarj edebilirsiniz. ASRock APP Charger birçok Apple cihazını aynı anda ve hızlı bir biçimde şarj etmenize olanak tanır ve hatta bilgisayarınız Bekleme modunda (S1), RAM'de Askıya Al modunda (S3), uyku modunda (S4) veya kapalı(S5) iken sürekli şarj etmeyi destekler. APP Charger sürücüsü kurulu iken kolaylıkla şimdiki hiç olmadığı kadar harika bir şarj deneyimi yaşayabilirsiniz.  
ASRock internet sitesi: <http://www.asrock.com/Feature/AppCharger/index.asp>
9. İnternet tarayıcısının yeni bir işlevi olan SmartView, en sık ziyaret ettiğiniz web sitelerini, geçmişinizi, Facebook arkadaşlarınızı ve sizin gerçek zamanlı haber beslemelerinizi, daha kişisel bir İnternet deneyimi için geliştirilmiş bir görünümde birleştiren IE için akıllı başlangıç sayfasıdır. ASRock anakartları, hareket halindeki arkadaşlarınızla irtibat halinde kalmanıza yardım eden SmartView yardımcı programı ile donatılmıştır. SmartView özelliğini kullanmak için işletim sistemi sürümünüzün Windows® 7 / 7 64 bit / Vista™ / Vista™ 64 bit, ve tarayıcı sürümünüzün IE8 olmasına dikkat edin. ASRock web sitesi: <http://www.asrock.com/Feature/SmartView/index.asp>
10. ASRock XFast USB, USB bellek aygıtı performansını artırabilir. Performans aygıtının özelliğine göre değişiklik gösterebilir.
11. ASRock XFast LAN hızlı internet erişimi sağlarken aşağıdaki avantajlara da sahiptir. LAN uygulaması Önceliklendirmesi: Uygulama önceliğinizi ideal şekilde yapılandırabilir ve/veya yeni programlar ekleyebilirsiniz. Oyunda Daha Az Gecikme Zamanı: Çevrimiçi oyun önceliğini daha yükseğe ayarladığınızda, oyundaki gecikmeler azalabilir. Trafik Şekillendirme: YouTube HD video izleyebilir ve aynı anda dosyaları indirebilirsiniz. Verilerinizi Gerçek Zamanlı Analizi: Durum penceresi ile, şu anda aktardığınız hangi verilerin akışının yapıldığını kolaylıkla yapılandırabilirsiniz.
12. ASRock XFast Şarj Aleti, mobil cihazlarınızı bilgisayarınızdan şarj etmek için kullanabileceğiniz en iyi ve en hızlı teknolojidir. Kusursuz XFast Şarj Aleti USB bağlantı noktasıyla, kullanıcılar cihazlarını her zaman hızlı şarj edebilecekler. Şarj aleti, Apple ürünlerine ek olarak, BC 1.1 standart akıllı cihazları şarj edebilmektedir. Ayrıntılı bilgi için, lütfen 35. sayfaya bakınız.
13. ASRock XFast RAM, F-Stream eklenen yeni bir işlev. Windows® 32-bit

işletim sistemi CPU'su altında kullanılmayan bellek alanından tamamen yararlanır. ASRock XFast RAM webde sörfü şimdiye kadar olmadığı kadar hızlandırırken önceden ziyaret edilen web sitelerinin yüklenme süresini kısaltır. Ayrıca Adobe Photoshop'ın hızını 5 kat artırır. ASRock XFast RAM'in başka bir avantajı da, SSD veya HDD'lerinize erişim sıklığını azaltarak kullanım ömürlerini uzatması.

14. ASRock Crashless BIOS kullanıcıların arıza çıkma korkusu olmadan BIOS'larını güncellemesine imkan verir. BIOS güncelleme işlemi sırasında güç kaybı yaşanırsa, ASRock Crashless BIOS güç geri geldiğinde BIOS güncelleme işlemi otomatik olarak tamamlayacaktır. Lütfen, BIOS dosyalarının USB diskinizin kök dizinine yerleştirilmesi gerektiğini unutmayın. Bu özelliği yalnızca USB2.0 bağlantı noktaları desteklemektedir.
15. Bu anakart adimsiz kontrole izin verse de aşırı hızlandırma uygulamanız önerilmez. Önerilen CPU veri yolu frekansları dışındaki frekanslar sistemin dengesi olmasına veya CPU'nun zarar görmesine neden olabilir.
16. CPU aşırı ısınması algılandığında, sistem otomatik olarak kapatılır. Sistemi devam ettirmeden önce, lütfen anakarttaki CPU fanının düzgün çalıştığını kontrol edin ve güç kablosunu çıkarın, sonra geri takın. Isı geçişini artırmak için, PC sisteminizi yüklediğinizde CPU ile ısı emici arasına ısı macunu sürmeyi unutmayın.
17. Intel Rapid Storage Technology enterprise 3.0 ve ASRock XFast RAM, Microsoft® Windows® XP / XP 64-bit ile uyumlu değildir.
18. Enerji Kullanan Ürün anlamına gelen EuP, tamamlanmış sistemler için güç tüketimini tanımlamak için Avrupa Birliği tarafından düzenlenen bir gerekliliktir. EuP'a göre, kapalı mod durumunda tamamlanmış sistemin toplam AC gücü 1,00W altında olmalıdır. EuP standardını karşılamak için, EuP hazır anakart ve EuP hazır güç kaynağı gerekir. Intel'in önerisine göre, EuP hazır güç kaynağının 100 mA akım tüketiminde 5v beklemede güç etkinliği %50'den yüksektir standardını karşılaması gerekir. EuP hazır güç kaynağı seçimi için, daha fazla ayrıntı için güç kaynağı üreticisine başvurmanızı öneririz.



### 1.3 Jumper'ların Ayarı

Şekilde jumper'ların nasıl ayarlandıkları gösterilmektedir. Jumper kapağı pinler üzerine yerleştirildiğinde jumper "Kapalı" dır. Jumper kapağı pinler üzerindeyken jumper "Açık" tır. Şekilde pin 1 ve pin 2'si "Kapalı" olan jumper kapağı bu 2 pine yerleştirilmiş 3-pinli jumper gösterilmektedir.



#### Jumper

#### Ayar

##### CMOS'u temizleme

(CLRCMOS1, 3-pinli jumper)  
(bkz. s.4 No. 25)



Default



Clear CMOS

Not: CLRCMOS1, CMOS'daki verilerinizi temizlemenize olanak sağlar. Sistem parametrelerini temizlemek ve varsayılan ayara sıfırlamak için lütfen bilgisayarı kapatın ve güç kablosunun fişini güç kaynağından çekin. 15 saniye bekledikten sonra, pin2 ve pin3'ü CLRCMOS1'de 5 saniye kısaltmak için bir atlatici şapkası kullanın. Ancak, BIOS'u güncelledikten hemen sonra lütfen CMOS'u temizlemeyin. BIOS'u güncellemeyi tamamladığınızda CMOS'u temizlemeniz gerekirse, ilk olarak sistemi başlatmanız ve ardından CMOS temizleme işlemini gerçekleştirmeden önce kapatmanız gereklidir. Parola, tarih, saat, kullanıcı varsayılan profili, 1394 GUID ve MAC adresinin yalnızca CMOS pili çıkarıldığında temizleneceğini lütfen aklınızda bulundurunuz.



CMOS Devresini Temizle, CMOS Ayarı'nı Temizle ile aynı işleve sahiptir.

## 1.4 Yerleşik Fişler ve Konektörler

Yerleşik fişler ve konektörler jumper DEĞİLDİR. Bu fişlerin ve konektörlerin üzerine jumper kapakları YERLEŞTİRMEYİN. Fişlerin ve konektörlerin üzerine jumper kapakları yerleştirmek anakartın kalıcı olarak zarar görmesine neden olabilir!

### Seri ATA2 Konektörler

(SATA\_0\_1: bkz. s.4, No. 13)

(SATA\_2\_3: bkz. s.4, No. 12)

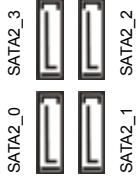

Bu dört Seri ATA2 (SATA2) konektör, dahili depolama cihazları için SATA veri kablolarını destekler. Geçerli SATA2 arayüzü 3,0 Gb/sn veri aktarım hızına izin verir.

### Seri ATA3 Konektörler

(SATA3\_0\_1: bkz. s.4, No. 14)

(SATA3\_M0\_M1: bkz. s.4, No. 15)

(SATA3\_M2\_M3: bkz. s.4, No. 16)

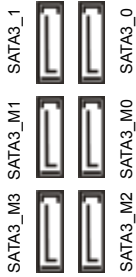

Bu altı Seri ATA3 (SATA3) konektör, dahili depolama cihazları için SATA veri kablolarını destekler. Geçerli SATA3 arayüzü 6,0 Gb/sn veri aktarım hızına izin verir.

### Seri ATA (SATA)

#### Veri Kablosu

(İsteğe bağlı)



SATA veri kablosunu her iki ucu da SATA / SATA2 / SATA3 sabit diskine veya anakarttaki SATA2 / SATA3 konektörüne bağlanabilir.

### Seri ATA (SATA) Güç Kablosu

(İsteğe bağlı)



Lütfen SATA güç kablosunun siyah ucunu her sürücüde bulunan güç konektörüne bağlayın. Sonra, SATA güç kablosunun beyaz ucunu güç kaynağının güç konektörüne bağlayın.

## USB 2.0 Fişleri

(9-pinli USB\_6\_7)

(bkz. s.4 No. 29)

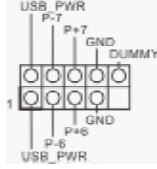

(9-pinli USB\_8\_9)

(bkz. s.4 No. 28)

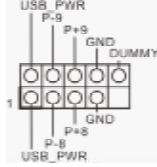

(9-pinli USB\_10\_11)

(bkz. s.4 No. 27)

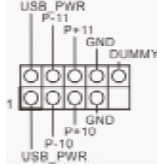

G/Ç panelindeki varsayılan altı USB 2.0 portundan başka, bu anakartta üç USB 2.0 fişi bulunur. Her USB 2.0 fişi iki USB 2.0 portunu destekler.

## USB 3.0 Fişleri

(19-pinli USB3\_5\_6)

(bkz. s.4 No. 8)

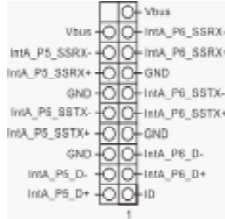

(19-pinli USB3\_7\_8)

(bkz. s.4 No. 9)

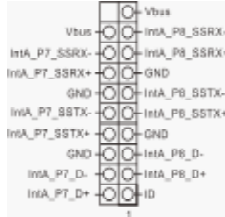

I/O panelinde bulunan iki adet varsayılan USB 3.0 bağlantı noktasının yanı sıra, bu ana kart üzerinde iki adet USB 3.0 bağlantısı bulunur. Bu USB 3.0 bağlantısı iki adet USB 3.0 bağlantı noktasını destekleyebilir.

## Kızılötesi Modül Fişi

(5-pinli IR1)

(bkz. s.4 No. 37)

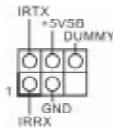

Bu fiş, isteğe bağlı bir kablosuz aktarma ve alma kızılötesi modülünü destekler.

## Kullanıcı Kızılötesi Modül Bağlantısı

(4-pinli CIR1)

(bkz. s.4 No. 30)



Bu bağlantı, HI-FI ve TV setleri gibi isteğe bağlı kullanıcı kızılötesi cihazlarını bağlamak için kullanılabilir.

## Ön Panel Ses Fişi

(9-pinli HD\_SESI)

(bkz. s.4 No. 35)

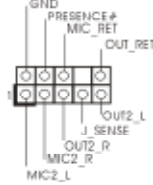

Bu, panel ses kablosu için uygun bağlantı sağlayan ve ses cihazlarını kontrol etmeyi sağlayan bir arayüzdür.



1. Yüksek Tanımlı Ses Jak Duyarlılığını destekler, ancak kasadaki panel kablosunun HDA'nın düzgün çalışmasını desteklemesi gerekir. Lütfen sisteminizi yüklemek için kılavuzumuzdaki ve kasa kılavuzundaki talimatları izleyin.
2. AC'97 ses paneli kullanıyorsanız, lütfen ön panel ses fişine aşağıdaki gibi takın:
  - A. Mic\_IN'i (MIC) MIC2\_L'ye bağlayın.
  - B. Audio\_R'yi (RIN) OUT2\_R'ye ve Audio\_L'yi (LIN) OUT2\_L'ye bağlayın.
  - C. Ground'u (GND) Ground'a (GND) bağlayın.
  - D. MIC\_RET ve OUT\_RET yalnızca HD ses paneli içindir. Bunları AC'97 ses paneli için bağlamanız gerekmez.
  - E. Ön mikrofonu etkinleştirmek için Windows® XP / XP 64-bit İS için:  
"Karıştırıcı"yı seçin. "Kaydedici"yi seçin. Sonra "Ön Mikrofon"u tıklatın.  
Windows® 7 / 7 64-bit / Vista™ / Vista™ 64-bit İS için:  
Realtek Kontrol panelinde "Ön Mikrofon" Sekmesine gidin. "Kayıt Ses Seviyesi"ni ayarlayın.

## Sistem Paneli Fişi

(9-pinli PANEL1)

(bkz. s.4 No. 22)

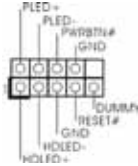

Bu fiş, birçok sistem ön paneli işlevini barındırır.



Kasa üzerindeki güç anahtarını, sıfırlama anahtarını ve sistem durumu göstergesini aşağıdaki pin atamalarına göre bu bağlantıya bağlayın. Kabloları bağlamadan önce pozitif ve negatif pinlere dikkat edin.

### PWRBTN (Güç Anahtarı):

Kasa üzerindeki güç anahtarını ön panele bağlayın. Güç anahtarını kullanarak sisteminizi kapatma şeklinizi yapılandırabilirsiniz.

### RESET (Sıfırlama Anahtarı):

Kasa üzerindeki sıfırlama anahtarını ön panele bağlayın. Bilgisayar donarsa veya normal bir yeniden başlatma gerçekleştirilemezse, bilgisayarı yeniden başlatmak için sıfırlama anahtarına basın.

### PLED (Sistem Gücü LED'i):

Kasa üzerindeki güç durumu göstergesini ön panele bağlayın. Sistem çalışırken LED yanar. Sistem S1 uykü modunda iken LED yanıp sönmeye devam eder. Sistem S3/S4 uykü modunda veya kapalı (S5) iken LED söner.

### HDLED (Sabit Disk Çalışma LED'i):

Kasa üzerindeki sabit disk çalışma LED'ini ön panele bağlayın. Sabit disk veri okurken veya yazarken LED yanar.

Ön panel tasarımı kasaya göre değişiklik gösterebilir. Ön panel modülünde temel olarak güç anahtarı, sıfırlama anahtarı, güç LED'i, sabit disk çalışma LED'i, hoparlör vb. bulunur. Kasa ön panel modülünüzü bu bağlantıya bağlarken, kablo atamalarının ve pin atamalarının doğru biçimde eşleştirildiğinden emin olun.

### Kasa Hoparlörü Fişi

(4-pinli SPEAKER1)  
(bkz. s.4 No. 21)

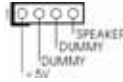

Lütfen kasa hoparlörünü bu fişe bağlayın.

### Güç LED'i Fişi

(3-pinli PLED1)  
(bkz. s.4 No. 23)



Sistem gücü durumunu belirtmek için lütfen kasa güç LED'ini bu fişe bağlayın. Sistem çalışırken LED açıktır. LED S1 durumunda yanıp sönmeye devam eder. LED S3/S4 durumunda veya S5 durumunda da (güç kapalı) kapalıdır.

### Kasa/güç Fan Konektörü

(3-pinli CHA\_FAN1)  
(bkz. s.4 No. 11)

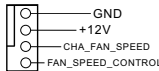

Lütfen kasa fan kablolarını fanına bu konektöre bağlayın ve siyah kabloyu toprak pinine bağlayın. CHA\_FAN1, CHA\_FAN2 ve CHA\_FAN3 destekli Fan Denetimi.

(3-pinli CHA\_FAN2)  
(bkz. s.4 No. 20)

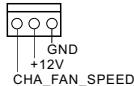

(3-pinli CHA\_FAN3)  
(bkz. s.4 No. 17)

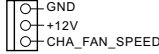

(3-pinli PWR\_FAN1)  
(bkz. s.4 No. 44)

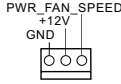

### CPU Fan Konektörü

4-pinli CPU\_FAN1)  
(bkz. s.4 No. 5)

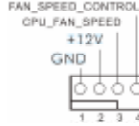

Lütfen fan kablolarını CPU fanına bu konektöre bağlayın ve siyah kabloyu toprak pinine bağlayın.



Bu anakart 4-Pinli CPU fan (Sessiz Fan) desteği sağlasa da, 3-Pinli CPU fan hızı kontrol işlevi olmadan bile hala başarılı bir şekilde çalışabilir. 3-Pinli CPU fanı bu konektördeki CPU fan konektörüne bağlamayı planlıyorsanız, lütfen Pin 1-3'e bağlayın.

**Pin 1-3 Bağlı** ←

3-Pinli Fanı Takma

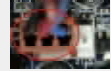

(3-pinli CPU\_FAN2)  
(bkz. s.4 No. 6)

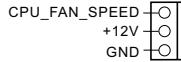

### ATX Güç Konektörü

(24-pinli ATXPWR1)  
(bkz. s.4 No. 7)

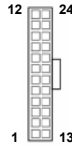

Lütfen bir ATX güç kaynağını bu konektöre bağlayın.



Bu anakart 24-pinli ATX güç konektörü sağlasa da geleneksel bir 20-pinli ATX güç kaynağı bağlarsanız da çalışabilir. 20-pinli ATX güç kaynağını kullanmak için, lütfen güç kaynağınızı Pin 1 ve Pin 13'le birlikte takın.

20-Pinli ATX Güç Kaynağını Takma

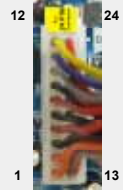

### ATX 12V Güç Konektörü

(8-pinli ATX12V1)  
(bkz. s.4 No. 3)

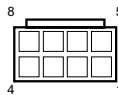

Lütfen bir ATX 12V güç kaynağını bu konektöre bağlayın.



Bu anakart 8-pinli ATX 12V güç konektörü sağlasa da geleneksel bir 4-pinli ATX 12V güç kaynağı bağlarsanız da çalışabilir. 4-pinli ATX güç kaynağını kullanmak için, lütfen güç kaynağınızı Pin 1 ve Pin 5'le birlikte takın.

4-Pinli ATX 12V Güç Kaynağını Takma



### SLI/XFIRE Güç Konektörü

(4-pinli SLI/XFIRE\_PWR1)

(bkz. s.4 No. 31)



SLI/XFIRE\_POWER1

Lütfen bir SLI/XFIRE güç kaynağını bu konektöre bağlayın.

### IEEE 1394 Fişi

(9-pinli FRONT\_1394)

(bkz. s.4 No. 34)

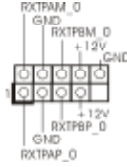

Bu anakartta G/Ç panelindeki bir varsayılan IEEE 1394 portunun yanı sıra, bir IEEE 1394 fişi (FRONT\_1394) de bulunur. Bu IEEE 1394 fişi bir IEEE 1394 portunu destekler.

### Seri port Fişi

(9-pinli COM1)

(bkz. s.4 No. 32)

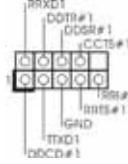

Bu COM1 fişi bir seri port modülünü destekler.

### HDMI\_SPDIF Fişi

(2-pinli HDMI\_SPDIF1)

(bkz. s.4 No. 33)



HDMI\_SPDIF fişi, SPDIF ses çıkışını HDMI VGA kartına sağlar, sistemin HDMI Dijital TV/projektör/LCD cihazlarını bağlamasına izin verir. Lütfen HDMI VGA kartının HDMI\_SPDIF konektörünü bu fişe bağlayın.

## Ön USB 3.0 Panelinin Kurulum Kılavuzu

**Adım 1** Verilen Ön USB 3.0 Panelini, dört HDD vidasını ve altı şasi vidasını hazırlayın.



**Adım 2** 2,5" HDD/SSD'yi Ön USB 3.0 Paneline dört adet HDD vidasını kullanarak vidalayın.



**Adım 3** Ön USB 3.0 Panelini şasinin 2,5" sürücüsü yuvasına kurun.



**Adım 4** Ön USB 3.0 Panelini altı şasi vidası ile sürücü yuvasına vidalayın.



**Adım 5** Ön USB 3.0 kablosunu anakarttaki USB 3.0 başlığına (USB3\_5\_6 veya USB3\_7\_8) takın.



**Adım 6** Ön USB 3.0 Paneli zaten kullanılıyor.



## Arka USB 3.0 Braketinin Kurulum Kılavuzu

**Adım 1** Ön USB 3.0 Panelinden iki vidayı sökün.



**Adım 2** USB 3.0 kablosunu ve arka USB 3.0 braketini bir araya getirin.



**Adım 3** İki vidayı arka USB 3.0 braketine vidalayın.



**Adım 4** Arka USB 3.0 braketini kasaya yerleştirin.





## 1.5 Akıllı Anahtarlar

Bu anakartta üç akıllı anahtar bulunur: güç anahtarı, sıfırlama anahtarı ve CMOS'u temizleme anahtarı; bunlar kullanıcıların hızlı bir şekilde sistemi açıp kapatmalarını veya CMOS değerlerini temizlemelerini sağlar.

### Güç Anahtarı

(PWRBTN)

(bkz. s.4 No.18)



Güç Anahtarı, kullanıcıların hızlı bir şekilde sistemi açıp kapatmalarını sağlayan akıllı bir anahtardır.

### Sıfırlama Anahtarı

(RSTBTN)

(bkz. s.4 No.19)



Sıfırlama Anahtarı, kullanıcıların hızlı bir şekilde sistemi sıfırlamalarını sağlayan akıllı bir anahtardır.

### CMOS'u Temizleme Anahtarı

(CLRSBTN)

(bkz. s.5 No.18)



CMOS'u Temizleme Anahtarı, kullanıcıların hızlı bir şekilde CMOS değerlerini temizlemelerini sağlayan akıllı bir anahtardır.

---

## 2. BIOS Bilgileri

Anakarttaki Flash Bellek BIOS Ayarları Yardımcı Programını içerir. Bilgisayarı başlattığınızda, lütfen Otomatik Güç Sınaması (POST) sırasında BIOS Ayarları yardımcı programına girmek için <F2> veya <Del> tuşuna basın; aksi halde, POST test rutinlerine devam eder. BIOS Ayarlarına POST'tan sonra girmek istiyorsanız, lütfen <Ctl> + <Alt> + <Delete> tuşlarına basarak veya sistem kasasındaki sıfırlama düğmesine basarak sistemi yeniden başlatın. BIOS Ayarları programı kullanıcı dostu olacak şekilde tasarlanmıştır. Çeşitli alt menüler arasında dolaşmanıza ve önceden belirlenen seçenekler arasından seçim yapmanıza izin veren menü tabanlı bir programdır. BIOS Ayarları hakkında ayrıntılı bilgi için, lütfen Destek CD'sinde bulunan Kullanıcı Kılavuzu'na (PDF dosyası) başvurun.

## 3. Yazılım Destek CD'si bilgileri

Bu anakart çeşitli Microsoft® Windows® işletim sistemleri destekler: 7 / 7 64-bit / Vista™ / Vista™ 64-bit / XP / XP 64-bit. Anakartla birlikte gelen Destek CD'si anakart özelliklerini genişleten gerekli sürücüler ve kullanışlı yardımcı programları içerir. Destek CD'sini kullanmaya başlamak için, CD'yi CDROM sürücünüze takın. Bilgisayarınızda "OTOMATİK KULLAN" özelliği etkinleştirilmişse, Ana Menüü otomatik olarak görüntüler. Ana Menü otomatik olarak görüntülenmezse, menüleri görüntülemek için Destek CD'sinin "BIN" klasöründeki "ASSETUP.EXE" dosyasını bulun ve çift tıklayın.

# 1. 제품소개

**Fatal1ty X79 Professional Series** 메인 보드를 구매하여 주신것에 대하여 감사 드립니다. 이 메인보드는 엄격한 품질관리 하에 생산되어진 신뢰성 있는 메인보드입니다. 이 제품은 고 품격 디자인과 함께 ASRock의 우수한 품질과 최고의 안정성을 자랑하고 있습니다. 이 빠른 설치 안내서에는 마더보드에 대한 설명과 단계별 설치 방법이 실려 있습니다. 마더보드에 대한 보다 자세한 내용은 지원 CD의 사용 설명서에서 확인할 수 있습니다.



메인보드의 사양이나 바이오스가 업데이트 되기 때문에 이 사용자 설명서의 내용은 예고 없이 변경되거나 바뀔 수가 있습니다. 만을 생각해서 이 사용자 설명서의 어떤 변경이 있으면 ASRock의 웹 사이트에서 언제든지 업데이트를 하실 수 있습니다. 웹사이트에서 최신 VGA 카드와 CPU 지원 목록을 확인할 수 있습니다. ASRock의 웹사이트 주소는 <http://www.asrock.com>입니다.

본 마더보드와 관련하여 기술 지원이 필요한 경우 당사 웹사이트를 방문하여 사용 중인 모델에 대한 특정 정보를 얻으십시오.

[www.asrock.com/support/index.asp](http://www.asrock.com/support/index.asp)

## 1.1 패키지 내용

**Fatal1ty X79 Professional Series** 마더보드

(ATX 폼 팩터 : 12.0" x 9.6" , 30.5 x 24.4 cm)

**Fatal1ty X79 Professional Series** 쿼크 설치 가이드

**Fatal1ty X79 Professional Series** 지원 CD

시리얼 ATA (SATA) 데이터 케이블 6 개 (선택 사양)

시리얼 ATA (SATA) HDD 전원 케이블 2 개 (선택 사양)

I/O 차폐 1 개

USB 3.0 전면 패널 1 개

HDD 나사 4 개

새시나사 6 개

후면 USB 3.0 브래킷 1개

ASRock SLI\_ 브릿지 카드 2 개

ASRock SLI\_ 브릿지 \_3S 카드 1 개

ASRock 3-Way SLI Bridge 카드 1 개



**ASRock은사용자에게 알립니다...**

Windows® 7 / 64-비트 / Vista™ / Vista™ 64-비트의 성능을 향상시키기 위해서 Storage Configuration(스토리지 구성)에서 BIOS 옵션을 AHCI 모드로 설정하는 것이 좋습니다. BIOS 설정과 관련하여 자세한 내용은 지원 CD에 포함된 “사용 설명서”를 참조하십시오.

## 1.2 설명서

플랫폼	<ul style="list-style-type: none"> <li>- ATX 폼 팩터 : 12.0" x 9.6" , 30.5 x 24.4 cm</li> <li>- 프리미엄 골드 콘덴서디자인 (100% 일본산 고품질 정도성 고분자 콘덴서)</li> </ul>
CPU	<ul style="list-style-type: none"> <li>- LGA 2011 소켓용 Intel® Core™ i7 프로세서 제품 지원</li> <li>- Digi 전원 설계</li> <li>- 고급 16 + 2 전원 위상 디자인</li> <li>- Intel® Turbo Boost 2.0 기술 지원</li> <li>- 하이퍼 - 스레딩 기술 지원 (주의 1 참조)</li> <li>- 언타이드 오버클러킹 (Untied Overclocking) 기술 지원</li> </ul>
칩셋	<ul style="list-style-type: none"> <li>- Intel® X79</li> </ul>
메모리	<ul style="list-style-type: none"> <li>- Quad Channel DDR3 메모리 기술 (주의 2 참조)</li> <li>- DDR3 DIMM 슬롯 4 개</li> <li>- DDR3 2400+(OC)/2133(OC)/1866(OC)/1600/1333/1066 비 -ECC, 언버퍼드 메모리를 지원</li> <li>- Socket LGA 2011 에서 Intel® Workstation 1S Xeon® 프로세서 E5 16xx/26xx/46xx 시리즈로 버퍼링되지 않은 메모리 DDR3 ECC 지원</li> <li>- 최대 시스템 메모리 용량 : 32GB (주의 3 참조)</li> <li>- Intel® 익스트림 메모리 프로파일 (XMP) 1.3/1.2 지원</li> </ul>
확장 슬롯	<ul style="list-style-type: none"> <li>- 4 x PCI Express 3.0 x16 슬롯 (PCIe1/PCIe2/PCIe4/PCIe5 : x16/8/16/0 모드 ; x16/8/8/8 모드) (주의 4 참조)</li> <li>- 1 개의 PCI Express 2.0 x1 슬롯</li> <li>- 2 개의 PCI 슬롯</li> <li>- AMD Quad CrossFireX™, 4 웨이 CrossFireX™, 3 웨이 CrossFireX™ 및 CrossFireX™ 지원</li> <li>- NVIDIA® Quad SLI™, 4 웨이 SLI™, 3 웨이 SLI™ 및 SLI™ 지원</li> </ul>
오디오	<ul style="list-style-type: none"> <li>- 7.1 CH HD Audio 목록 보호 (Realtek ALC898 Audio Codec)</li> <li>- Premium Blu-ray 오디오 지원</li> <li>- THX TruStudio™ 지원</li> </ul>
랜	<ul style="list-style-type: none"> <li>- PCIe x1 Gigabit LAN 10/100/1000 Mb/s</li> <li>- Broadcom BCM57781</li> <li>- 웨이크 - 온 - 랜 지원</li> <li>- 절전형 이더넷 802.3az 지원</li> <li>- PXE 지원</li> </ul>
후면판 I/O	<ul style="list-style-type: none"> <li>I/O Panel</li> <li>- 1 개 PS/2 키보드 포트</li> <li>- 1 개 동축 SPDIF 출력 포트</li> <li>- 1 개 광학 SPDIF 출력 포트</li> </ul>

	<ul style="list-style-type: none"> <li>- 5 개디폴트 USB 2.0 포트</li> <li>- 1 개 Fatal1ty 마우스 포트 (USB 2.0)</li> <li>- 2 개 eSATA3 커넥터</li> <li>- 4 개디폴트 USB 3.0 포트</li> <li>- 1 개 LED(ACT/LINK LED 및 SPEED LED) 가 있는 RJ-45 LAN 포트</li> <li>- 1 개 IEEE 1394 포트</li> <li>- 1 개 CMOS 삭제 스위치</li> <li>- 오디오 잭 : 측면 스피커 / 후방 스피커 / 중앙 / 저음 / 라인 인 / 전방 스피커 / 마이크 ( 주의 5 참조 )</li> </ul>
SATA3	<ul style="list-style-type: none"> <li>- Intel® X79 SATA3 6.0Gb/s 커넥터 2개, 하드웨어 RAID (RAID 0, RAID 1, RAID 5, RAID 10 및 Intel Rapid Storage 3.0), NCQ, AHCI 및 "Hot Plug" ( 핫플러그 ) 기능 지원</li> <li>- Marvell SE9172 SATA3 6.0Gb/s 커넥터 4 개 , 하드웨어 RAID (RAID 0, RAID 1), NCQ, AHCI 및 "Hot Plug" ( 핫플러그 ) 기능 지원</li> </ul>
USB 3.0	<ul style="list-style-type: none"> <li>- TI® 에 의한 후면 패널 USB 3.0 포트 4 개 , 최고 5Gb/s 의 USB 1.0/2.0/3.0 지원</li> <li>- TI® 에 의한 전면 패널 USB 3.0 헤더 2 개 (USB 3.0 포트 4 개 지원 ) , 최고 5Gb/s 의 USB 1.0/2.0/3.0 지원</li> </ul>
온보드 헤더 및 커넥터	<ul style="list-style-type: none"> <li>- 4 개 의 SATA2 3.0Gb/s 커넥터 , RAID (RAID 0, RAID 1, RAID 5, RAID 10 및 Intel Rapid Storage3.0) 기능지원 , NCQ, AHCI 및 "핫 플러그" 기능지원</li> <li>- 6 개 의 SATA3 6.0Gb/s 커넥터</li> <li>- 적외선 모듈 헤더 1 개</li> <li>- 소비자용 적외선 모듈 헤더 1 개</li> <li>- COM 포트 헤더 1 개</li> <li>- HDMI_SPDIF 헤더 1 개</li> <li>- IEEE 1394 헤더 1 개</li> <li>- 전원 LED 헤더 1 개</li> <li>- CPU/ 새시 / 전원 팬 커넥터</li> <li>- 24 핀 ATX 전원 헤더</li> <li>- 8 핀 ATX 12V 파워 콘넥터</li> <li>- SLI/XFIRE 전원 헤더</li> <li>- 전면부 오디오 콘넥터</li> <li>- USB 2.0 헤더 3 개 ( 6 개의 추가 USB 2.0 포트를 지원하는헤더 2 개 )</li> <li>- USB 3.0 헤더 2 개 ( 4 개의 추가 USB 3.0 포트를 지원하는헤더 2 개 )</li> <li>- Dr. Debug ( 7 세그먼트 디버그 LED ) 1 개</li> </ul>
빠른 스위치	<ul style="list-style-type: none"> <li>- LED 가 달린 전원 스위치 1 개</li> </ul>

	<ul style="list-style-type: none"> <li>- LED 가 달린 리셋 스위치 1 개</li> <li>- LED 가 달린 CMOS 삭제 스위치 1 개</li> </ul>
BIOS	<ul style="list-style-type: none"> <li>- 64Mb GUI 지원을 제공하는 AMI UEFI 적합형 BIOS</li> <li>- “플러그 앤 플레이” 지원</li> <li>- ACPI 1.1 웨이크 - 업 이벤트와의 호환</li> <li>- 접퍼 프리 지원</li> <li>- SMBIOS 2.3.1 지원</li> <li>- CPU, VCCSA, DRAM, VTT, CPU PLL, PCH1.1V, PCH1.5V 전압 멀티 조절</li> </ul>
지원 CD	<ul style="list-style-type: none"> <li>- 드라이버, 유틸리티, 백신 소프트웨어 (시험판), CyberLink MediaEspresso 6.5 평가판, ASRock 소프트웨어 세트 (ASRock MAGIX Multimedia Suite - OEM)</li> </ul>
특점 및 특성	<ul style="list-style-type: none"> <li>- F-Stream (주의 6 참조)</li> <li>- ASRock Instant Boot</li> <li>- ASRock Instant Flash (주의 7 참조)</li> <li>- ASRock APP Charger (주의 8 참조)</li> <li>- ASRock SmartView (주의 9 참조)</li> <li>- ASRock XFast USB (주의 10 참조)</li> <li>- ASRock XFast LAN (주의 11 참조)</li> <li>- ASRock XFast 충전기 (주의 12 참조)</li> <li>- ASRock XFast RAM (주의 13 참조)</li> <li>- ASRock Crashless BIOS (주의 14 참조)</li> <li>- 하이브리드 부스터 : <ul style="list-style-type: none"> <li>- CPU 주파수의 단계적인 조절 (주의 15 참조)</li> <li>- ASRock U-COP (주의 16 참조)</li> <li>- B.F.G.(Boot Failure Guard)</li> </ul> </li> <li>- 굿나잇 LED</li> </ul>
하드웨어 모니터	<ul style="list-style-type: none"> <li>- CPU 온도 감지</li> <li>- 마더보드 온도 감지</li> <li>- CPU/ 새시 / 전원 팬 회전 속도계 : 샤시 (케이스) 팬 회전 속도계</li> <li>- CPU/ 새시 저소음 팬 (CPU 온도에 의한 새시 팬속도 자동 조정 가능)</li> <li>- CPU/ 새시 팬 멀티스피드 컨트롤</li> <li>- 전압 감시 기능 : +12V, +5V, +3.3V, Vcore</li> </ul>
OS	<ul style="list-style-type: none"> <li>- 마이크로 소프트 Windows® 7/7 64 비트 / Vista™ / Vista™ 64 비트 / XP/XP 64 비트 와 호환 (주의 17 참조)</li> </ul>
인증서	<ul style="list-style-type: none"> <li>- FCC, CE, WHQL</li> <li>- ErP/EuP 지원 (ErP/EuP 지원 전원 공급기가 요구됨) (주의 18 참조)</li> </ul>

\* 상세한 제품정보는 당사의 웹사이트를 방문할수있습니다 . <http://www.asrock.com>



## 경고

오버클로킹에는 BIOS 설정을 조정하거나 Untied Overclocking Technology 를 적용하거나 타업체의 오버클로킹 도구를 사용하는 것을 포함하여 어느 정도의 위험이 따르다는 것을 유념하십시오. 오버클로킹은 시스템 안정성에 영향을 주거나 심지어 시스템의 구성 요소와 장치에 손상을 입힐지도 모릅니다. 오버클로킹은 사용자 스스로 위험과 비용을 감수하고 해야 합니다. 당사는 오버클로킹에 의해 발생할 수 있는 손상에 대해서 책임이 없습니다.

## 주의!

1. 하이퍼-스레딩 기술의 셋팅에 대하여는 지원 CD의 사용자 매뉴얼의 67 페이지를 참고하세요.
2. 이 마더보드는 Quad Channel DDR3 메모리 기술을 지원합니다. Quad Channel DDR3 메모리 기술을 구현하기 전에 올바른 설치를 위하여 18 쪽에 있는 메모리 모듈 설치 안내를 읽으십시오.
3. 운영 체제 한계 때문에 Windows® 7 / Vista™ / XP 에서 시스템 용도로 예약된 실제 메모리 크기는 4 GB 이하일 수 있습니다. 64 비트 CPU 와 Windows® OS 의 경우 그런 한계가 없습니다. ASRock XFast RAM 을 사용하여 Windows® 에서 사용할 수 없는 메모리를 이용할 수 있습니다.
4. 현재 Intel® Socket 2011 Sandy Bridge-E 프로세서는 PCIE 3.0 을 지원하지 않지만 이 마더보드는 이미 PCIE 3.0 하드웨어 준비 상태입니다. Intel CPU 의 PCIE 3.0 사용 여부에 달려 있습니다. 차후 CPU 업데이트 및 릴리즈 정보는 Intel 홈페이지를 확인하십시오.
5. 본 마더보드는 마이크 입력에 대해서 스테레오와 모노 모드 둘 다 지원합니다. 본 마더보드는 오디오 출력에 대해서 2 채널, 4 채널, 6 채널 및 8 채널 모드를 지원합니다. 올바른 연결을 위해 5 쪽에 나온 표를 확인하십시오.
6. F-Stream 는 사용자에게 친숙한 인터페이스로 다른 시스템 기능을 미세 조정하는 일체형 도구로서, 여기에는 하드웨어 모니터, 팬 컨트롤, 오버클로킹, OC DNA, IES 등이 포함되어 있습니다. 하드웨어 모니터는 시스템의 주요 값을 표시합니다. 팬 컨트롤은 조정하려는 팬 속도와 온도를 표시합니다. 오버클로킹에서는 CPU 주파수를 오버클로킹하여 최적의 시스템 성능으로 조정할 수 있습니다. OC DNA 에서는 OC 설정을 프로파일로 저장하고 이를 친구와 공유할 수 있습니다. 그러면 친구가 OS 프로파일을 자신의 시스템에 로드하여 동일한 OS 설정을 사용할 수 있습니다. IES (Intelligent Energy Saver) 의 경우, 전압 조절기로 출력위상의 수를 줄여 CPU 코어가 휴식 상태일 때 컴퓨터 성능을 저하시키지 않으면서 효율을 높일 수 있습니다.
7. ASRock Instant Flash 는 플래시 ROM 에 내장된 BIOS 유틸리티입니다. 이 편리한 BIOS 업데이트 툴을 사용하면 먼저 MS-DOS 나 Windows® 같은 운영 체제에 들어가지 않고도 시스템 BIOS 를 업데이트할 수 있습니다. POST 중 에 BIOS 셋업 메뉴에서 <F6> 키를 누르거나 <F2> 키를 누르면이 유틸리티로 ASRock Instant Flash 에 액세스할 수 있습니다. .. 이제 이 툴을 시작하여 USB

- 플래시 드라이브, 플로피 디스크 또는 하드 드라이브에 새 BIOS 파일을 저장하면 플로피 디스크이나 기타 복잡한 플래시 유틸리티를 추가로 준비하지 않고도 몇 번의 클릭만으로도 BIOS 를 업데이트할 수 있습니다. USB 플래시 드라이브 또는 하드 드라이브는 FAT32/16/12 파일 시스템을 사용해야 합니다.
8. 아이폰 / 아이팟 터치 / 아이패드와 같은 Apple 기기들을 더 빠르고 달뜰한 방식으로 충전하려는 경우, ASRock 이 제공하는 놀라운 솔루션인 ASRock APP Charger 를 이용하십시오. APP Charger 드라이버를 설치하기만 하면 아이폰이 컴퓨터를 통해서 훨씬 더 빨리 충전되며 충전 속도도 최대 40% 더 빨라집니다. ASRock APP Charger 는 많은 Apple 기기를 동시에 빨리 충전할 수 있게 하며, PC 가 대기 모드 (S1), RAM 에 대한 일시 중단 (S3), 최대 절전 모드 (S4) 또는 전원 꺼짐 모드 (S5) 에 들어갈 때도 연속충전을 지원합니다. APP Charger 드라이버를 설치하면 그 어느 때보다 더 간편하고 빠르게 충전할 수 있습니다.  
ASRock 웹사이트 : <http://www.asrock.com/Feature/AppCharger/index.asp>
  9. 인터넷 브라우저의 새로운 기능인 SmartView 는 가장 많이 방문한 웹사이트, 사용자의 검색 기록, 페이스북 친구, 실시간 뉴스 피드를 더 개인적인 인터넷 경험을 위한 향상된 보기로 결합하는 IE 용 스마트 시작 페이지입니다. ASRock 마더보드에만 친구들과 즉시 연락하도록 도와 주는 SmartView 유틸리티가 탑재되어 있습니다. SmartView 기능을 이용하려면 OS 버전이 Windows® 7 / 7 64 비트 / Vista™ / Vista™ 64 비트이고 브라우저 버전이 IE8 인지 확인하십시오.  
ASRock 웹사이트 : <http://www.asrock.com/Feature/SmartView/index.asp>
  10. ASRock XFast USB 는 USB 스토리지 장치 성능을 높여줍니다. 성능은 장치의 속성에 따라 다를 수 있습니다.
  11. ASRock XFast LAN 은 더 빠른 인터넷 접속과 아래와 같은 이점을 제공합니다. LAN 응용 프로그램 우선순위 결정 : 응용 프로그램 우선순위를 이상적으로 구성할 수 있고 / 또는 새 프로그램을 추가할 수 있습니다. 게임 지연 시간 감소 : 온라인 게임 우선순위를 더 높게 설정한 후 게임 지연 시간을 낮출 수 있습니다. 트래픽 형성 : Youtube HD 비디오를 보면서 동시에 파일을 다운로드할 수 있습니다. 데이터의 실시간 분석 : 상태창에서 현재 어떤 데이터 스트림을 전송 중인지 쉽게 알 수 있습니다.
  12. ASRock XFast 충전기는 PC 를 통한 모바일 디바이스를 충전하는 가장 빠른 최고의 기술입니다. 최고로 빠른 충전기 USB 포트로 언제든지 빠른 충전 경험을 즐길 수 있습니다. Apple 디바이스에 대하여 BC 1.1 표준 스마트 디바이스 충전도 가능합니다. 세부 정보는 35 페이지를 참조하십시오.
  13. ASRock XFast RAM 은 F-Stream 에 포함된 새로운 기능입니다. Windows® OS 32-bit CPU 에서는 사용할 수 없는 메모리 공간을 사용합니다. ASRock XFast RAM 은 이전에 방문했던 웹사이트의 로딩 시간을 단축하며 웹 서핑을 이전보다 더 빠르게 합니다. 또한 Adobe Photoshop 속도를 5 배 증가 시킵니다. ASRock XFast RAM 의 또 다른 장점은 SSD 또는 HDD 의 액세스 빈도를 줄여 수명을 확장 늘입니다.
  14. ASRock Crashless BIOS 로 실패 없이 BIOS 를 업데이트할 수 있습니다. BIOS 업데이트 중에 전원 공급이 끊긴 후 전원이 다시 공급되면 ASRock Crashless BIOS 가 자동으로 BIOS 업데이트 과정을 완료합니다. BIOS 파일은 USB 디스크의 루트 디렉토리에 위치해야 합니다. USB2.0 포트만 이 기능을 지원합니다.



15. 본 마더보드는 직접 조절 기능을 제공하지만, 오버 클러킹을 하는것은 권장되지 않습니다. 권장하는 CPU 주파수 외에 다른 주파수를 설정 시에는 시스템이 불안정해지거나, 메인보드와 CPU의 불량이 발생 할 수 있으므로 가급적 사용하지 마십시오.
16. 시스템을 다시 시작하기 전에 메인보드 위의 CPU 팬이 정상적으로 동작 또는 장착되어 있는지 확인하여 주십시오. 고온 방지를 위하여 PC 시스템을 설치할 때 CPU와 방열판사이에 그리스를 발라 주셔야 합니다.
17. Intel Rapid Storage Technology Enterprise 3.0 와 ASRock XFast RAM 은 Microsoft® Windows® XP / XP 64- 비트 규격에서 지원되지 않습니다.
18. EuP 는 Energy Using Product ( 에너지 사용 제품 ) 의 약어이며 유럽 연합이 완제품 시스템의 전력 소비량을 정의하기 위해 제정한 표준이었습니다. EuP 에 따르면, 완제품 시스템의 총 AC 전원은 끄기 모드 상태에서 1.00W 미만이어야 합니다. EuP 표준을 충족하려면 EuP 지원 마더보드 및 EuP 지원 전원공급장치가 필요합니다. 인텔 (Intel) 의 제안에 따르면 EuP 지원 전원공급장치는 5V 대기 전력 효율이 100 mA 전류 소비 하에서 50% 보다 높아야 한다는 기준을 충족해야 합니다. EuP 지원 전원공급장치를 선택하려면 전원공급장치 제조업체에 자세한 사항을 문의하시기 바랍니다.



## 1.4 온보드 헤더 및 커넥터



### 주의!

이 콘넥터는 점퍼가 아닙니다. 이 콘넥터 위에 점퍼 캡을 사용하지 마세요. 커넥터에 점퍼 캡을 설치하면 마더보드가 영구적으로 손상됩니다!

### 시리얼 ATA2 커넥터

(SATA2\_0\_1:

4 페이지, 13 번 항목 참조)

(SATA2\_2\_3:

4 페이지, 12 번 항목 참조)

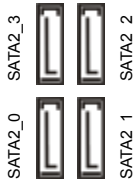

4 개의 시리얼 ATA2 (SATA) 커넥터는 내부 저장 장치용 SATA 데이터 케이블을 지원합니다. 커넥터가 내부 기억 장치용 SATA 케이블을 지원합니다. 현재의 SATA2 인터페이스는 최고 3.0 Gb/s 의 데이터 전송 속도를 지원합니다.

### 시리얼 ATA3 커넥터

(SATA3\_0\_1:

4 페이지, 14 번 항목 참조)

(SATA3\_M0\_M1:

4 페이지, 15 번 항목 참조)

(SATA3\_M2\_M3:

4 페이지, 16 번 항목 참조)

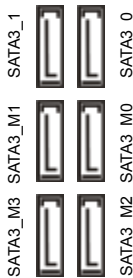

6 개의 시리얼 ATA3 (SATA3) 커넥터는 내부 저장 장치용 SATA 데이터 케이블을 지원합니다. 커넥터가 내부 기억 장치용 SATA 케이블을 지원합니다. 현재의 SATA3 인터페이스는 최고 6.0 Gb/s 의 데이터 전송 속도를 지원합니다.

### 시리얼 ATA(SATA)

데이터 케이블

(선택 사양)



SATA 데이터 케이블의 임의적인 측을 마더보드의 SATA / SATA2 / SATA3 하드 디스크 혹은 SATA2 / SATA3 커넥터에 연결합니다.

### 시리얼 ATA(SATA)

전원 케이블

(선택 사양)



SATA 전원 케이블의 검은 색 끝 부분을 드라이브의 전원 커넥터에 연결하십시오. 그 다음에 SATA 전원 케이블의 흰색 끝을 전원 공급장치의 전원 커넥터에 연결합니다.

### USB 2.0 헤더

(9 핀 USB\_6\_7)

(4 페이지, 29 번 항목 참조)

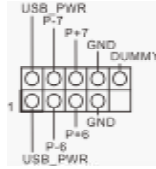

(9 핀 USB\_8\_9)

(4 페이지, 28 번 항목 참조)

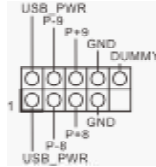

(9 핀 USB\_10\_11)

(4 페이지, 27 번 항목 참조)

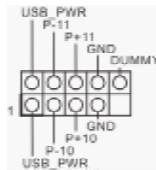

본 머더보드에는 I/O 패널에 있는 6 개의 기본 USB 2.0 포트의 예도 USB 2.0 헤더가 3 개 있습니다. 각각의 USB 2.0 헤더는 2 개의 USB 2.0 포트를 지원할 수 있습니다.

### USB 3.0 헤더

(19 핀 USB3\_5\_6)

(4 페이지, 8 번 항목 참조)

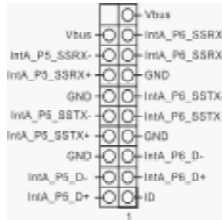

I/O 패널에 있는 4 개의 기본적인 USB 3.0 포트 이외에도 마더보드에 2 개의 USB 3.0 헤더가 있습니다. 이 USB 3.0 헤더는 2 개의 USB 3.0 포트를 지원할 수 있습니다.

(19 핀 USB3\_7\_8)

(4 페이지, 9 번 항목 참조)

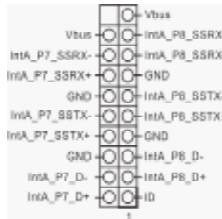

### 적외선 모듈 헤더

(5 핀 IR1)

(4 페이지, 37 번 항목 참조)

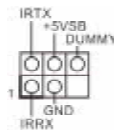

이 헤더는 선택품목인 무선 적외선 송수신 모듈을 지원합니다.



### 소비자용 적외선 모듈 헤더

(4 편 CIR1)

(4 페이지, 30 번 항목 참조)



이 헤더는 리모콘 수신기 연결하는 데 사용될 수 있습니다.

### 전면부 오디오 콘넥터

(9 편 HD\_AUDIO1)

(4 페이지, 35 번 항목 참조)

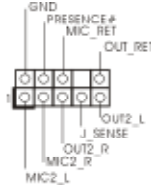

이 콘넥터는 오디오 장치를 하게 조절하고 연결할 수 있는 전면 오디오 인터페이스입니다.



1. High Definition Audio(고음질 오디오)는 잭 센스 기능을 지원하나, 제대로 작동하려면 새시의 패널 와이어가 HAD 를 지원해야 합니다. 이 설명서 및 새시 설명서의 지침을 따라 시스템을 설치하십시오.
2. AC' 97 오디오 패널을 사용하는 경우, 이를 아래와 같이 프런트 패널의 오디오헤더에 설치하십시오.
  - A. Mic\_IN(MIC)을 MIC2\_L에 연결합니다.
  - B. Audio\_R(RIN)을 OUT2\_R에 연결하고, Audio\_L(LIN)을 OUT2\_L에 연결합니다.
  - C. Ground(GND)을 Ground(GND)에 연결합니다.
  - D. MIC\_RET 및 OUT\_RET는 HD 오디오 패널 전용입니다. 이들을 AC' 97 오디오 패널에 연결하지 않아도 됩니다.
  - E. 앞면 마이크 작동.  
Windows® XP / XP 64 비트 OS의 경우:  
"Mixer" (믹서)와 "Recorder" (리코더)를 선택한 후 "Front Mic" (앞면 마이크)를 선택합니다.  
Windows® 7 / 7 64 비트 / Vista™ / Vista™ 64 비트 OS의 경우:  
Realtek 제어판에서 "FrontMic" (앞면 마이크)로 가서 "Recording Volume" (리코딩 볼륨)을 조정합니다.

### 시스템 콘넥터

(9 편 PANEL1)

(4 페이지, 22 번 항목 참조)

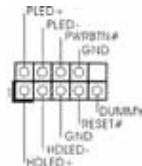

이 콘넥터는 시스템 전면 패널 기능을 지원하기 위한 것입니다.



새시의 전원 스위치, 리셋 스위치, 시스템 상태 표시등을 아래의 핀 할당에 따라 이헤더에 연결합니다. 케이블을 연결하기 전에 양극 핀과 음극 핀을 기록합니다.

PWRBTN( 전원 스위치):

새시 전면 패널의 전원 스위치에 연결합니다. 전원 스위치를 이용해 시스템을 끄는방법을 구성할 수 있습니다.

RESET( 리셋 스위치):

새시 전면 패널의 리셋 스위치에 연결합니다. 컴퓨터가 정지하고 정상적 재시작을수행하지 못할 경우 리셋 스위치를 눌러 컴퓨터를 재시작합니다.

PLED( 시스템 전원 LED):

새시 전면 패널의 전원 상태 표시등에 연결합니다. 시스템이 작동하고 있을 때는LED가 켜져 있습니다. 시스템이 S1 대기 상태에 있을 때는LED가 계속 깜박입니다. 시스템이 S3/S4 대기 상태 또는 전원 꺼짐 (S5) 상태에 있을 때는LED가 꺼져 있습니다.

HDLED( 하드 드라이브 동작 LED):

새시 전면 패널의 하드 드라이브 동작 LED에 연결합니다. 하드 드라이브가 데이터를읽거나 쓰고 있을 때 LED가 켜져 있습니다.

전면 패널 디자인은 새시별로 다를 수 있습니다. 전면 패널 모듈은 주로 전원 스위치, 리셋 스위치, 전원 LED, 하드 드라이브 동작 LED, 스피커 등으로 구성되어 있습니다. 새시 전면 패널 모듈을 이 헤더에 연결할 때 와이어 할당과 핀 할당이 정확히 일치하는지 확인합니다.

### 새시 스피커 헤더

(4 핀 SPEAKER 1)

(4 페이지, 21 번 항목 참조)

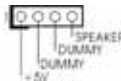

새시 스피커를 이 헤더에 연결하십시오.

### 전원 LED 헤더

(3 핀 PLED1)

(4 페이지, 23 번 항목 참조)



시스템 전원 상태를 표시하려면 새시 전원 LED를 헤더에 연결하십시오. 시스템 작동 중에는 LED에 전원이 켜져 있습니다. S1 상태에서는 LED가 계속 깜박입니다. S3/S4 상태 또는 S5 상태에서는 LED가 꺼집니다 (전원 꺼짐).

### 새시 / 전원 팬 커넥터

(4 핀 CHA\_FAN1)

(4 페이지, 11 번 항목 참조)

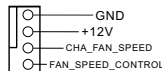

(3 핀 CHA\_FAN2)

(4 페이지, 20 번 항목 참조)

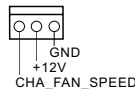

팬 케이블을 팬 커넥터에 연결하고 접지 핀에는 검은색 전선을 연결하십시오. CHA\_FAN1/2/3 팬 속도는 UEFI 또는 AXTU를 통하여 제어할 수 있습니다. CHA\_FAN1, CHA\_FAN2 및 CHA\_FAN3은 팬 제어를 지원합니다.



(3 핀 CHA\_FAN3)  
(4 페이지, 17 번 항목 참조)

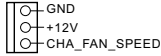

(3 핀 PWR\_FAN1)  
(4 페이지, 44 번 항목 참조)

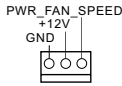

CPU 팬 커넥터  
(4 핀 CPU\_FAN1)  
(4 페이지, 5 번 항목 참조)

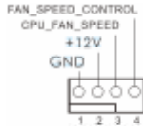

CPU 팬 케이블을 이 커넥터에 연결하고 흑색 선을 접지 핀에 맞추십시오.



본 마더보드가 4 핀 CPU 팬 (저소음 팬) 지원을 제공하기는 하지만 팬 속도 제어기능없이도 3 핀 CPU 팬을 성공적으로 작동할 수 있습니다. 본 마더보드의 CPU 팬 커넥터에 3 핀 CPU 팬을 연결하려면 1-3 번 핀에 연결하십시오.

1-3 번 핀에 연결됨 ←  
3 핀 팬 설치

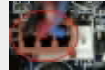

(3 핀 CPU\_FAN2)  
(4 페이지, 6 번 항목 참조)

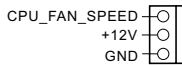

ATX 전원 헤더  
(24 핀 ATXPWR1)  
(4 페이지, 7 번 항목 참조)

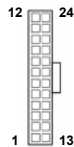

ATX 전원 공급기를 이 헤더에 연결하십시오.



이 마더보드는 24 핀 ATX 전원 커넥터를 제공하지만, 종래의 20 핀 ATX 전원 공급장치를 사용해도 작동이 가능합니다. 20 핀 ATX 전원 공급장치를 사용하려면, Pin 1 과 Pin 13 으로 전원공급장치를 연결하십시오.

20 핀 ATX 전원 공급장치 설치

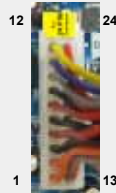

ATX 12V 파워 콘넥터  
(8 핀 ATX12V1)  
(4 페이지, 3 번 항목 참조)

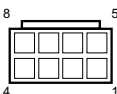

ATX 12V 전원 공급기를 이 헤더에 연결하십시오.



비록 본 마더보드는 8-핀 ATX 12V 전원 연결기를 제공하지만 이것은 여전히작업할수있습니다. 만약 전통적인 4-핀 ATX 12V 전원공급을 채용하여 4-핀 ATX 전력을 사용하는 경우, 반드시 전원 공급을 핀 1 과 핀 5 에전원공급을 삽입해야합니다.



4-핀 ATX 12V 전원공급장치

### SLI/XFIRE 전원 커넥터

(4 핀 SLI\_XFIRE\_POWER1)

(4 페이지, 31 번 항목 참조)



SLI\_XFIRE\_POWER1

이 커넥터를 사용하지 않아도 되나, 2 개의그래픽카드를 이 마더보드에 동시에연결하는 경우에는이커넥터를 하드 디스크 전원 커넥터에 연결하십시오.

### IEEE 1394 헤더

(9 핀 FRONT\_1394)

(4 페이지, 34 번 항목 참조)

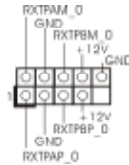

이번 머더보드에는 I/O 패널에 있는 1 개의 기본 IEEE 1394 포트외에도 IEEE 1394 (FRONT\_1394) 헤더가 1 개 있습니다. 각각의 IEEE 1394 헤더는 1 개의 IEEE 1394 포트를 지원할 수 있습니다.

### 시리얼포트 컨넥터

(9 핀 COM1)

(4 페이지, 32 번 항목 참조)

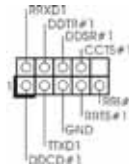

이 콘넥터는 시리얼 포트 모듈을 지원합니다.

### HDMI\_SPDIF 헤더

(2 핀 HDMI\_SPDIF1)

(4 페이지, 33 번 항목 참조)



HDMI VGA 카드에 SPDIF 오디오 출력을 제공하는 HDMI\_SPDIF 헤더는 시스템이 HDMI 디지털 TV/ 프로젝터 / LCD 장치에 연결할 수 있게 합니다. HDMI VGA 카드의 HDMI\_SPDIF 커넥터를 이 헤더에 연결하십시오.





## 전면 USB 3.0 패널의 설치 안내서

- 1 단계** 번들 프론트 USB 3.0 패널, 네 개의 나사, 여섯 개의 새시 나사를 준비합니다.



- 3 단계** 전면 USB 3.0 패널을 새시의 2.5" 드라이브 베이에 설치합니다.



- 5 단계** 전면 USB 3.0 케이블을 마더보드의 USB 3.0 헤더(USB3\_5\_6 또는 USB3\_7\_8)에 연결합니다.



- 2 단계** 네 개의 HDD 나사를 사용하여 2.5" HDD/SSD 를 프론트 USB 3.0 패널을 고정합니다.



- 4 단계** 여섯 개의 새시 나사를 사용하여 프론트 USB 3.0 패널을 드라이브 베이에 고정합니다.



- 6 단계** 전면 USB 3.0 패널이 사용 준비가 완료됩니다.



## 후면 USB 3.0 브래킷의 설치 안내서

- 1 단계** 전면 USB 3.0 패널에서 두 개의 나사를 제거합니다.



- 3 단계** 후면 USB 3.0 패널에 두 개의 나사를 장착합니다.



- 2 단계** USB 3.0 케이블과 후면 USB 3.0 브래킷을 연결합니다.



- 4 단계** 후면 USB 3.0 브래킷을 새시에 장착합니다.



---

## 1.5 빠른 스위치

이 메인보드에는 세 개의 빠른 스위치, 즉 전원 스위치, 리셋 스위치 및 CMOS 삭제 스위치가 있어, 사용자가 빠르게 시스템을 켜고 끄거나 리셋하고 CMOS 값을 삭제할 수 있습니다.

---

### 전원 스위치

(PWRBTN)

(4 페이지, 18 번 항목 참조)



전원 스위치는 빠른 스위치로서, 사용자가 시스템을 빠르게 켜거나 끌 수 있습니다.

---

### 리셋 스위치

(RSTBTN)

(4 페이지, 19 번 항목 참조)



리셋 스위치는 빠른 스위치로서, 사용자가 시스템을 빠르게 리셋할 수 있습니다.

---

### CMOS 삭제 스위치

(CLRBTN)

(5 페이지, 18 번 항목 참조)



CMOS 삭제 스위치는 빠른 스위치로서, 사용자가 CMOS 값을 빠르게 삭제할 수 있습니다.

---

## 2. 시스템 바이오스 정보

메인보드의 플래쉬 메모리에는 바이오스 셋업 유틸리티가 저장되어 있습니다. 컴퓨터를 사용하실 때, “자가진단 테스트” (POST) 가 실시되는 동안 <F2> 또는 <Del> 키를 눌러 바이오스 셋업으로 들어가세요; 만일 그렇게 하지 않으면 POST 는 테스트 루틴을 계속하여 실행할 것입니다. 만일 POST 이후 바이오스 셋업을 하기 원하신다면, <Ctl>+<Alt>+<Delete> 키를 누르거나, 또는 시스템 본체의 리셋 버튼을 눌러 시스템을 재 시작하여 주시기 바랍니다. 바이오스 셋업 프로그램은 사용하기 편하도록 디자인되어 있습니다. 각 항목은 다양한 서브 메뉴 표가 올라오며 미리 정해진 값 중에서 선택할 수 있도록 되어 있습니다. 바이오스 셋업에 대한 보다 상세한 정보를 원하신다면 보조 CD 안의 포함된 사용자 매뉴얼 (PDF 파일) 을 따라 주시기 바랍니다.

## 3. 소프트웨어 지원 CD 정보

이 메인보드는 여러 가지 마이크로소프트 윈도우 운영 체계를 지원합니다:  
7/7 64 비트 /Vista™/Vista™ 64 비트 /XP/XP 64 비트. 메인보드에 필요한 드라이버와 사용자 편의를 위해 제공되는 보조 CD 는 메인보드의 기능을 향상시켜 줄 것입니다. 보조 CD 를 사용하여 시작하시려면, CD-ROM 드라이브에 CD 를 넣어주시기 바랍니다. 만일 고객님의 컴퓨터가 “AUTORUN” 이 가능하다면 자동으로 메인 메뉴를 모니터에 디스플레이 시켜 줄 것입니다. 만일 자동으로 메인 메뉴가 나타나지 않는다면, 보조 CD 의 디스플레이 메뉴 안에 있는 BIN 폴더 ASSETUP.EXE 파일을 더블 클릭하여 주시기 바랍니다.

# 1. はじめに

**Fatal1ty X79 Professional Series** マザーボードをお買い上げいただきありがとうございます。本製品は、弊社の厳しい品質管理の下で製作されたマザーボードです。本製品は、弊社の品質と耐久性の両立という目標に適合した堅牢な設計により優れた性能を実現します。このクイックインストールガイドには、マザーボードの説明および段階的に説明したインストールの手引きが含まれています。マザーボードに関するさらに詳しい情報は、「サポート CD」のユーザーマニュアルを参照してください。



マザーボードの仕様および BIOS ソフトウェアは、アップデートされることがありますので、マニュアルの内容は、予告なしに変更されることがあります。本マニュアルに変更があった場合は、弊社のウェブサイトに通告なしに最新版のマニュアルが掲載されます。最新の VGA カードおよび CPU サポートリストもウェブサイトでご覧になれます。ASRock 社ウェブサイト:<http://www.asrock.com>  
このマザーボードに関連する技術サポートが必要な場合、当社の Web サイトにアクセスし、使用しているモデルについての特定情報を見つけてください。  
[www.asrock.com/support/index.asp](http://www.asrock.com/support/index.asp)

## 1.1 パッケージ内容

**Fatal1ty X79 Professional Series** マザーボード:

(ATX フォームファクター: 12.0-in x 9.6-in, 30.5 cm x 24.4 cm)

**Fatal1ty X79 Professional Series** クイックインストールガイド

**Fatal1ty X79 Professional Series** サポート CD

- 6 x シリアル ATA (SATA) データケーブル(オプション)
- 2 x シリアル 1 ATA (SATA) HDD 用電源変換ケーブル(オプション)
- 1 x I/O パネルシールド
- 1 x USB 3.0 前面パネル
- 4 x HDD ねじ
- 6 x 筐体ねじ
- 1 x 背面USB 3.0ブラケット
- 2 x ASRock SLI\_Bridge カード
- 1 x ASRock SLI\_Bridge\_3S カード
- 1 x ASRock 3-Way SLI Bridge カード



### ASRockからのお知らせ...

Windows® 7 / 7 64-bit / Vista™ / Vista™ 64-bit でより良い性能を得るには、ストレージ構成の BIOS オプションを AHCI モードに設定することを推奨します。BIOS のセットアップについての詳細は、サポート CD の「ユーザーマニュアル」を参照してください。

## 1.2 仕様

プラットフォーム	<ul style="list-style-type: none"> <li>- ATX フォームファクター： 12.0-in x 9.6-in, 30.5 cm x 24.4 cm</li> <li>- プレミアムゴールド固体コンデンサ設計 (日本製高品質 100% 導電性高分子コンデンサ)</li> </ul>
CPU	<ul style="list-style-type: none"> <li>- LGA 2011 ソケットに対し、Intel® Core™ i7 プロセッサファミリーをサポートします。</li> <li>- デジタル電源設計</li> <li>- 高度な 16 + 2 電源位相設計</li> <li>- Intel® Turbo 2.0 ブーストテクノロジーをサポート</li> <li>- ハイバースレッドテクノロジーをサポート (注意 1 を参照)</li> <li>- Untied Overclocking をサポート</li> </ul>
チップセット	- Intel® X79
メモリー	<ul style="list-style-type: none"> <li>- クオッドチャネル DDR3 メモリ技術 (注意 2 を参照)</li> <li>- DDR3 DIMM スロット x 4</li> <li>- DDR3 2400+(OC)/2133(OC)/1866(OC)/1600/1333/1066 non-ECC, un-buffered メモリーに対応</li> <li>- DDR3 ECC アンバッファードメモリ、Intel® Workstation 1S Xeon® プロセッサ E5 16xx/26xx/46xx シリーズをソケット LGA 2011 でサポート</li> <li>- システムメモリの最大容量: 32GB (注意 3 を参照)</li> <li>- Intel® Extreme Memory Profile (XMP)1.3/1.2 をサポート</li> </ul>
拡張スロット	<ul style="list-style-type: none"> <li>- 4 x PCI Express 3.0 x16 スロット (PCIe1/PCIe2/PCIe4/PCIe5 : x16/8/160 モード、x16/8/8/8 モード) (注意 4 を参照)</li> <li>- 1 x PCI Express 2.0 x1 スロット</li> <li>- 2 x PCI スロット</li> <li>- AMD Quad CrossFireX™、4-Way CrossFireX™、3-Way CrossFireX™ および CrossFireX™ をサポート</li> <li>- NVIDIA® Quad SLI™、4-Way SLI™、3-Way SLI™ および SLI™ をサポート</li> </ul>
オーディオ	<ul style="list-style-type: none"> <li>- 7.1 CH HD オーディオ (コンテンツ保護付) (Realtek ALC898 オーディオ Codec)</li> <li>- Premium Blu-ray オーディオのサポー</li> <li>- THX TruStudio™ をサポート</li> </ul>
LAN	<ul style="list-style-type: none"> <li>- PCIe x1 Gigabit LAN 10/100/1000 Mb/s</li> <li>- Broadcom BCM57781</li> <li>- Wake-On-LAN をサポート</li> <li>- Energy Efficient Ethernet 802.3az をサポート</li> <li>- PXE をサポート</li> </ul>

リアパネル I/O	<p>I/O Panel</p> <ul style="list-style-type: none"> <li>- PS/2 キーボードポート x 1</li> <li>- 同軸 SPDIF 出力ポート x 1</li> <li>- 光学 SPDIF 出力ポート x 1</li> <li>- Ready-to-Use USB 2.0 ポート x 5</li> <li>- Fatal1ty マウスポート (USB 2.0) x 1</li> <li>- eSATA3 コネクタ x 2</li> <li>- Ready-to-Use USB 3.0 ポート x 4</li> <li>- LED(ACT/LINK LED および SPEED LED)付き RJ-45 LAN ポート x 1</li> <li>- IEEE 1394 ポート x 1</li> <li>- クリア CMOS スイッチ x 1</li> <li>- オーディオジャック:側面のスピーカー、後部スピーカー、中央、低音入力、前部スピーカー、マイク入力 (注意 5 参照)</li> </ul>
SATA3	<ul style="list-style-type: none"> <li>- Intel® X79 SATA3 6.0Gb/秒 コネクタ x 2 ハードウェアをサポート RAID (RAID 0, RAID 1, RAID 5, RAID 10 および Intel Rapid Storage3.0)をサポート, NCQ, AHCI および “Hot Plug” (ホットプラグ) 機能</li> <li>- Marvell SE9172 SATA3 6.0Gb/秒 コネクタ x 4 ハードウェアをサポート RAID (RAID 0, RAID 1), NCQ, AHCI および “Hot Plug” (ホットプラグ) 機能</li> </ul>
USB 3.0	<ul style="list-style-type: none"> <li>- 4 x リア USB 3.0 ポート (TI®)、USB 1.0/2.0/3.0 に最高 5Gb/s まで対応</li> <li>- 2 x フロント USB 3.0 ヘッダ (USB 3.0 ポート 4 基対応) (TI®)、USB 1.0/2.0/3.0 に最高 5Gb/s まで対応</li> </ul>
コネクタ	<ul style="list-style-type: none"> <li>- 4 x SATA2 3.0Gb/秒コネクタが、RAID (RAID 0, RAID 1, RAID 5, RAID 10 および Intel Rapid Storage3.0)をサポート, NCQ, AHCI および “Hot Plug” (ホットプラグ) 機能</li> <li>- 6 x SATA3 6.0Gb/秒コネクタが</li> <li>- IR ヘッダー x 1</li> <li>- コンシューマー赤外線モジュールヘッダー x 1</li> <li>- COM ポートヘッダ x 1</li> <li>- HDMI_SPDIF ヘッダー x 1</li> <li>- IEEE 1394 ヘッダー x 1</li> <li>- 電源 LED ヘッダー x 1</li> <li>- CPU / シャーシ / 電源ファンコネクタ</li> <li>- 24 ピン ATX 電源コネクタ</li> <li>- 8 ピン 12V 電源コネクタ</li> <li>- SLI/XFIRE 電源コネクタ</li> <li>- フロントパネルオーディオコネクタ</li> <li>- USB 2.0 ヘッダー (USB 2.0 用 6 ポートをサポート) x 3</li> </ul>

	<ul style="list-style-type: none"> <li>- USB 3.0 ヘッダー (USB 3.0 用 4 ポートをサポート) x 2</li> <li>- 1 x Dr. Debug (7-セグメント Debug LED)</li> </ul>
クイックス イッセ	<ul style="list-style-type: none"> <li>- 1 x 電源スイッチ(LED 付き)</li> <li>- 1 x リセットスイッチ(LED 付き)</li> <li>- 1 x クリア CMOS スイッチ(LED 付き)</li> </ul>
BIOS 関連機能	<ul style="list-style-type: none"> <li>- 64Mb AMI UEFI Legal BIOS(GUI サポート)</li> <li>- プラグ&amp;プレイをサポート</li> <li>- ACPI 1.1 準拠ウェイクアップイベント</li> <li>- jumperfree モードサポート</li> <li>- SMBIOS 2.3.1 サポート</li> <li>- CPU, VCCSA, DRAM, VTT, CPU PLL, PCH1.IV, PCH1.5V 電圧のマルチ調整</li> </ul>
サポート CD	<ul style="list-style-type: none"> <li>- ドライバ、ユーティリティ、AntiVirusソフトウェア(試用バージョン)、CyberLink MediaEspresso 6.5 試用版、ASRock ソフトウェアスイート(ASRock MAGIX Multimedia Suite - OEM)</li> </ul>
特徴	<ul style="list-style-type: none"> <li>- F-Stream (注意 6 参照)</li> <li>- ASRock インスタントブート</li> <li>- ASRock Instant Flash (注意 7 参照)</li> <li>- ASRock APP エャージャー (注意 8 を参照)</li> <li>- ASRock SmartView (注意 9 を参照)</li> <li>- ASRock XFast USB (注意 10 を参照)</li> <li>- ASRock XFast LAN (注意 11 を参照)</li> <li>- ASRock XFast チャージャー (注意 12 を参照)</li> <li>- ASRock XFast RAM (注意 13 を参照)</li> <li>- ASRock Crashless BIOS (注意 14 を参照)</li> <li>- ハイブリッドブースタ <ul style="list-style-type: none"> <li>- CPU 周波数無段階制御 (注意 15 を参照)</li> <li>- ASRock U-COP (注意 16 を参照)</li> <li>- 起動障害保護 (Boot Failure Guard:B.F.G.)</li> </ul> </li> <li>- グッドナイト LED</li> </ul>
モニター	<ul style="list-style-type: none"> <li>- CPU 温度検知</li> <li>- マザーボード温度検知</li> <li>- CPU/ シャーシ / 電源ファンタコメータ</li> <li>- CPU/ シャーシ 静音ファン(CPU 温度によりシャーシファン速度の自動調整が可能)</li> <li>- CPU/ シャーシ ファンマルチ速度制御</li> <li>- 電源モニター: +12V, +5V, +3.3V, Vcore</li> </ul>
OS	<ul style="list-style-type: none"> <li>- Microsoft® Windows®7 / 7 64-bit / Vista™ / Vista™ 64-bit / XP / XP 64-bit compliant(注意 17 を参照)</li> </ul>
認証	<ul style="list-style-type: none"> <li>- FCC, CE, Microsoft® WHQL 認証済み</li> <li>- ErP/EuP 対応(ErP/EuP 対応の電源装置が必要です)</li> </ul>

(注意 18 を参照)

\* 製品の詳細については、<http://www.asrock.com> を御覧ください。

#### 警告

オーバークロック (BIOS 設定の調整、アンタイド・オーバークロック・テクノロジーの適用、第三者のオーバークロックツールの使用など) はリスクを伴いますのでご注意ください。オーバークロックするとシステムが不安定になったり、システムのコンポーネントやデバイスが破損することがあります。ご自分の責任で行ってください。弊社では、オーバークロックによる破損の責任は負いかねますのでご了承ください。

#### 注意

1. “ハイパースレッドテクノロジー”の設定については、サポート CD の「ユーザーマニュアル」の 67 ページをエックしてください。
2. このマザーボードは、クオッドチャネル DDR3 メモリ技術 (Quad Channel Memory Technology) をサポートしております。クオッドチャネル DDR3 メモリ技術を実行する前に、正しいインストール法を理解する為に 18 ページのメモリーモジュールのインストールガイドをお読みください。
3. オペレーティングシステム制限のため、Windows® 7 / Vista™ / XP 使用下において、システム使用のリザーブに対する実際の記憶容量は 4GB 未満である可能性があります。64 ビット CPU の Windows® OS に対しては、そのような制限はありません。ASRock XFast RAM を使って Windows® が使用できないメモリを利用することができます。
4. 現在、Intel® Socket 2011 Sandy Bridge E プロセッサは、PCIe 3.0 をサポートしてませんが、このマザーボードは既に PCIe 3.0 ハードウェアに対応しています。PCIe 3.0 が有効かどうかは Intel 社の CPU に依存します。将来の CPU のアップデートとリリースに関する情報は、Intel 社ウェブサイトを確認してください。
5. マイク入力の場合、このマザーボードはステレオとモノラルモードをどちらもサポートします。オーディオ出力の場合、このマザーボードは 2 チャンネル、4 チャンネル、6 チャンネルと 8 チャンネルモードをサポートします。正しい接続については、5 ページの表をチェックしてください。
6. F-Stream は、分かりやすいインターフェイスでさまざまなシステム機能を微調整するオールインワンツールで、ハードウェアモニタ、ファンコントロール、オーバークロック、OC DNA、ES などを含んでいます。ハードウェアモニタでは、システムの主要な読み込みを示します。ファンコントロールでは、調整するファン速度と温度を示します。オーバークロックでは、CPU 周波数をオーバークロックして最適のシステムパフォーマンスを出すことができます。OC DNA では、プロファイルとして OC 設定を保存し友人と共有することができます。友人は OC プロファイルを自分のシステムに読み込んで、同じ OC 設定にすること





- が可能です。IES（インテリジェントエネルギーサーバー）では、電圧レギュレータにより、CPU コアがアイドルになっているときコンピュータの性能を犠牲にすることなく、多くの出力位相を削減して効率性の向上を図ります。
- ASRock Instant Flash は、Flash ROM(フラッシュ ROM)に組み込まれている BIOS フラッシュユーティリティです。この便利な BIOS 更新ツールにより、MS-DOS あるいは Windows® のように最初にオペレーティングシステムに入る必要なしに、システム BIOS を更新することができます。このユーティリティでは、POST の間に〈F6〉 キーを、あるいは BIOS 設置アップメニューの際に〈F2〉 キーを押すことで、ASRock Instant Flash にアクセスすることができます。このツールを起動し、新規 BIOS ファイルを USB フラッシュドライブ、フロッピーディスク、またはハードドライブに保存、そしていくつかのクリックだけで、その他のフロッピーディスクや複雑なフラッシュユーティリティを使用せずに BIOS を更新することができます。ご使用の際には、USB フラッシュドライブあるいはハードドライブが FAT32/16/12 ファイルシステムを使用していることを確認してください。
  - iPhone/iPad/iPod Touch など Apple デバイスを迅速かつお手軽に充電するために、ASRock では ASRock APP チャージャーという素晴らしいソリューションをご用意しています。APP チャージャードライバをインストールするだけで、ご使用の iPhone をコンピュータから素早く充電することができます。充電時間は従来より最高 40% も速くなります。ASRock APP チャージャーをお使いいただくと複数の Apple デバイスを同時に素早く充電できます。本製品は PC がスタンバイモード (S1)、メモリスuspendモード (S3)、休止モード (S4) または電源オフ (S5) の時にも継続充電をサポートします。APP チャージャードライバをインストールしていただくと、これまででない充電性能に充分ご満足いただけることでしょう。  
ASRock の Web サイト：  
<http://www.asrock.com/Feature/AppCharger/index.asp>
  - インターネットブラウザの新しい SmartView 機能は、よくアクセスするウェブサイト、閲覧履歴、Facebook の友達およびあなたのリアルタイムのニュースフィードを、よりパーソナルなインターネット体験のために改良されたビューに一体化させた、IE 用の賢いスタートページです。ASRock マザーボードは独占的に SmartView ユーティリティを備えており、あちこち移動する友達と連絡を取り合うのに役立ちます。SmartView 機能を使用するには、お使いの OS のバージョンが Windows® 7 / 7 64 bit / Vista™ / Vista™ 64 bit であり、ブラウザのバージョンが IE8 であることをご確認ください。  
ASRock ウェブサイト: <http://www.asrock.com/Feature/SmartView/index.asp>
  - ASRock XFast USB は USB ストレージデバイス性能を拡張することができます。デバイスの特長により性能は異なります。
  - ASRock XFast LAN は以下のメリットを含め、高速インターネットアクセスを提供します。LAN アプリケーション優先順位: アプリケーションの理想的な優先順位を設定し、新しいプログラムを追加することができます。ゲームの低いレイテンシ: オンラインゲームの優先順位を高く設定した後に、ゲームのレイテンシを下げるすることができます。トラフィックの成形: Youtube HD ビデオを視聴しながらファイルをダウンロードできます。データのリアルタイムの分析: ステータスウィンドウがあれば、現在転送しているデータストリームを容易に認識でき

- ます。
12. ASRock Xfast チャージャーは、PC 経由でモバイルデバイスを充電するための最高かつ高速の技術です。素晴らしい XFast チャージャー USB ポートを使えば、いつでも素早く充電することができます。Apple デバイスだけでなく、BC 1.1 標準スマートデバイスを充電することも可能です。詳細については、35 ページを参照してください。
  13. ASRock XFast RAM は、F-Stream を含む新機能です。Windows® オペレーティングシステム 32 ビット CPU の下では使用できないメモリ空間を利用します。ASRock XFast RAM は、以前に訪れたウェブサイトの表示にかかる時間を短縮し、これまで以上に迅速にネットサーフィンを行えるようにします。また、Adobe Photoshop の処理速度を 5 倍に押し上げます。ASRock XFast RAM の他の利点は、お使いの SSD または HDD へのアクセスを減らして、それらの寿命を延ばすことです。
  14. ASRock Crashless BIOS を使って、ユーザーは失敗のおそれなく BIOS を更新することができます。BIOS 更新プロセス中に電源損失が発生した場合、ASRock Crashless BIOS は電源回復後、自動的に BIOS 更新プロセスを完了させます。BIOS ファイルを USB ディスクのルートディレクトリに配置する必要があることに注意してください。USB 2.0 ポートのみがこの機能をサポートします。
  15. このマザーボードは、無段階制御を提供しますが、オーバークロックの実行はお薦めしません。推奨 CPU バス周波数以外の周波数は、システムを不安定にしたり CPU を損傷したりすることがあります。
  16. CPU のオーバーヒートが検出されると、システムは自動的にシャットダウンされます。システムのレジャームを行う前に、マザーボード上の CPU 冷却ファンが正しく機能しているか確認してから電源コードを外し、そして再度つないでください。放熱効果を高める為には、PC システムのインストール時に、CPU とヒートシンクの間に放熱グリースをスプレーするのが効果的です。
  17. Intel Rapid Storage Technology enterprise 3.0 と ASRock XFast RAM は、Microsoft® Windows® XP / XP 64 ビット準拠によりサポートされません。
  18. Energy Using Product (エコデザイン) の略語 EuP は完成システムの消費電力を定義するために欧州連合により規制された条項です。EuP に従って、管制システムの総 AC 電力はオフモード条件下で 1.00W 未満に抑える必要があります。EuP 規格を満たすには、EuP 対応マザーボードと EuP 対応電源が必要です。Intel の提案に従い、EuP 対応電源装置は規格を満たす必要があります。つまり 5v のスタンバイ電力効率は 100 mA の消費電流下で 50% 以上でなければなりません。EuP 対応電源装置を選択する場合、電源装置製造元に詳細を確認するようにお勧めします。

### 1.3 ジャンパ設定

右の図はジャンパがどのように設定されているかを示します。ジャンパキャップがピンに置かれている場合、ジャンパは“ショート”になります。ジャンパキャップがピンに置かれていない場合、ジャンパは“オープン”になります。右の図で、3ピンジャンパで、1-2ピンを“ショート”の場合、これらの2つのピンにジャンパキャップを置きます。



ジャンパ	設定	説明
CMOSの消去ジャンパ (CLR_CMOS1) ( ページ 4 アイテム 25 参照)	 デフォルト設定	 CMOSの消去

注： CLR\_CMOS1 により、CMOS のデータをクリアできます。システムパラメータをクリアしデフォルト設定にリセットするには、コンピュータの電源をオフにし、電源装置から電源コードを抜いてください。15 秒待ってから、ジャンパキャップを使用して CLR\_CMOS1 のピン 2 とピン 3 を 5 秒間ショートしてください。ただし、BIOS 更新の後すぐには CMOS をクリアしないでください。BIOS の更新の終了後直ちに CMOS をクリアする必要がある場合、まずシステムを起動してからシャットダウンし、その後クリア CMOS アクションを実行する必要があります。パスワード、日付、時刻、ユーザーデフォルトのプロファイルを忘れずにメモしてください。1394 GUID と MAC アドレスは、CMOS バッテリを取り外した場合のみ消去されます。



クリア CMOS スイッチには、クリア CMOS ジャンパと同じ機能があります。

## 1.4 オンボードのヘッダとコネクタ類



オンボードのヘッダとコネクタ類はジャンパではありません。それらのヘッダやコネクタにジャンパキャップをかぶせないでください。ヘッダやコネクタにジャンパキャップをかぶせると、マザーボードに深刻な影響を与える場合があります。

### シリアル ATA2 コネクタ

SATA2\_0\_1: ページ 4, アイテム 13 を参照

SATA2\_2\_3: ページ 4, アイテム 12 を参照

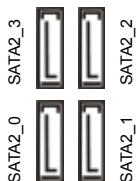

これら 4 本のシリアル ATA2 (SATA2) コネクタは内蔵ストレージデバイスに使用する SATA データケーブルに対応しています。現在の SATA2 インタフェースの最大データ転送速度は 3.0Gb/s です。

### シリアル ATA3 コネクタ

SATA3\_0\_1: ページ 4, アイテム 14 を参照

SATA3\_MQ\_M1: ページ 4, アイテム 15 を参照

SATA3\_M2\_M3: ページ 4, アイテム 16 を参照

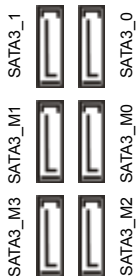

これら 6 本のシリアル ATA3 (SATA3) コネクタは内蔵ストレージデバイスに使用する SATA データケーブルに対応しています。現在の SATA3 インタフェースの最大データ転送速度は 6.0Gb/s です。

### シリアル ATA(SATA)

データケーブル(オプション)



SATA データケーブルのどちらかの端をマザーボードの SATA / SATA2 / SATA3 ハードディスク、または SATA2 / SATA3 コネクタに接続できます。

### シリアル ATA(SATA)

電源ケーブル(オプション)



SATA 電源ケーブルの黒端を各ドライブの電源コネクタに接続し、白端をパワーサプライの電源コネクタに接続してください。

### USB 2.0 ヘッド

(9ピン USB\_6\_7)

ページ 4, アイテム 29 を参照

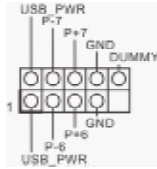

I/O パネルには、デフォルトの 6 つの USB 2.0 ポート以外に、このマザーボードに 3 つの USB 2.0 ヘッドが搭載されています。それぞれの USB 2.0 ヘッドは 2 つの USB 2.0 ポートをサポートできます。

(9ピン USB\_8\_9)

ページ 4, アイテム 28 を参照

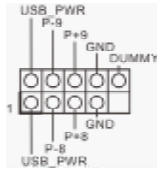

(9ピン USB\_10\_11)

ページ 4, アイテム 27 を参照

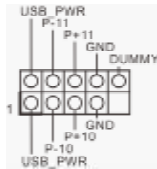

### USB 3.0 ヘッド

(19ピン USB3\_5\_6)

ページ 4, アイテム 8 を参照

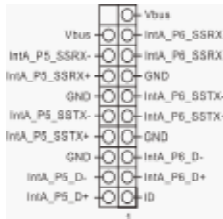

I/O パネルには、デフォルトの 4 つの USB 3.0 ポート以外に、このマザーボードに 2 つの USB 3.0 ヘッドが搭載されています。それぞれの USB 3.0 ヘッドは 2 つの USB 2.0 ポートをサポートできます。

(19ピン USB3\_7\_8)

ページ 4, アイテム 9 を参照

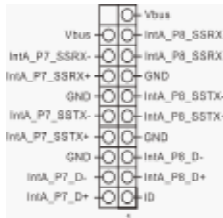

### 赤外線モジュールコネクタ

(5ピン IR1)

ページ 4, アイテム 37 を参照

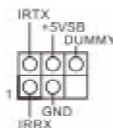

このコネクタは赤外線無線送受信モジュールに対応します。

コンシューマー赤外線モジュールヘッダー  
(4ピン CIR1)

ページ 4, アイテム 30 を参照

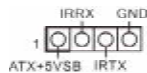

このヘッダーは、HI-FI セットや TV ボックスなどのオプションのコンシューマー赤外線デバイスの接続に使用することができます。

フロントオーディオパネルコネクタ  
(9ピン HD\_AUDIO1)

ページ 4, アイテム 35 を参照

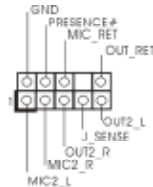

このコネクタは、オーディオ機器との便利な接続とコントロールを可能にするフロントオーディオパネルのためのインターフェイスです。



1. ハイディフィニションオーディオはジャックセンシングをサポートしますが、正しく機能するためにシャーシのパネルワイヤが HDA をサポートする必要があります。このマニュアルとシャーシのマニュアルの指示に従って、システムを取り付けてください。
2. AC'97 オーディオパネルを使用する場合、次のように前面パネルのオーディオヘッダに取り付けてください。
  - A. Mic\_IN (MIC) を MIC2\_L に接続します。
  - B. Audio\_R (RIN) を OUT2\_R に、Audio\_L (LIN) を OUT2\_L に接続します。
  - C. Ground (GND) を Ground (GND) に接続します。
  - D. MIC\_RET と OUT\_RET はオーディオパネル専用です。AC'97 オーディオパネルに接続する必要はありません。
  - E. フロントマイクを有効化するには。  
Windows® XP / XP 64-bit OS の場合：  
“Mixer” (ミキサー) を選択し、続いて “Recorder” (レコーダー) を選択します。その後 “FrontMic” (フロントマイク) をクリックします。  
Windows® 7 / 7 64-bit / Vista™ / Vista™ 64-bit OS の場合：  
Realtek コントロールパネルから “FrontMic” (フロントマイク) タブを開きます。“Recording Volume” (録音音量) を調整します。

システムパネルコネクタ  
(9ピン PANEL1)

ページ 4, アイテム 22 を参照

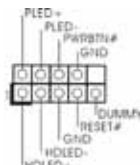

このコネクタは数種類のシステムフロントパネルの機能を提供します。



シャーシに付いている電源スイッチ、リセットスイッチ、システムステータスインジケータを下記のピン割り当て指示に従ってこのヘッダに接続します。ケーブルを接続する前にピンの正負極性にご注意ください。

**PWRBTN (電源スイッチ):**

前面パネルに付いている電源スイッチに接続します。電源スイッチによるシステム電源オフ方法を設定して変更することも可能です。

**RESET (リセットスイッチ):**

シャーシの前面パネルに付いているリセットスイッチに接続します。コンピュータがフリーズし、正常な再起動をしない場合は、リセットスイッチを押してコンピュータを再起動します。

**PLED (システム電源 LED):**

シャーシの前面パネルに付いている電源ステータスインジケータに接続します。LED は、システムが動作しているときに点灯します。LED はシステムが S1 スリープ状態のときに点滅します。システムが S3 または S4 スリープ状態になるか、電源オフ (S5) になると、LED は消灯します。

**HDLED (ハードドライブアクティビティ LED):**

シャーシの前面パネルに付いているハードドライブアクティビティ LED に接続します。LED は、ハードドライブがデータの読み込みまたは書き込み動作をしているときに点灯します。

前面パネルのデザインはシャーシによって異なります。前面パネルモジュールは、主に電源スイッチ、リセットスイッチ、電源 LED、ハードドライブアクティビティ LED、スピーカーなどから構成されています。シャーシの前面パネルモジュールをこのヘッダに接続する際は、ワイヤとピンの割り当てが正しく対応していることを確認してください。

シャーシスピーカーヘッダ

(4ピン SPEAKER1)

ページ 4、アイテム 21 を参照

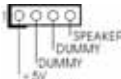

シャーシのスピーカーとこのヘッダを接続してください。

電源 LED ヘッダー

(3ピン PLED1)

ページ 4、アイテム 23 を参照



シャーシ電源 LED をこのヘッダーに接続し、システム電源ステータスを示すようにしてください。LED はシステムが動作中の際にオンになります。S1 ステータスでは LED は点滅し続けます。S3/S4 ステータス、または S5 ステータス (電源オフ) の場合、LED は消灯します。

### シャーシおよび電源ファンコネクタ

(4ピン CHA\_FAN1)

ページ 4, アイテム 11 を参照

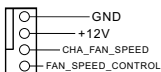

(3ピン CHA\_FAN2)

ページ 4, アイテム 20 を参照

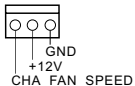

(3ピン CHA\_FAN3)

ページ 4, アイテム 17 を参照

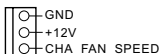

(3ピン PWR\_FAN1)

ページ 4, アイテム 44 を参照

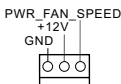

### CPU ファンコネクタ

(4ピン CPU\_FAN1)

ページ 4, アイテム 5 を参照

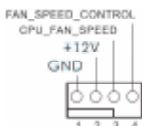

このコネクタには CPU ファケーブルを接続します。黒いコードはアースピンに接続してください。



このマザーボードでは 4 ピン CPU ファン (クワイエットファン) がサポートされていますが、ファン速度コントロール機能がない場合でも、3 ピン CPU ファンは正常に作動します。3 ピン CPU ファンをこのマザーボードの CPU ファンコネクタに接続しようとしている場合、ピン 1-3 に接続してください。

接続されたピン 1-3 ←  
3 ピンファンのインストール

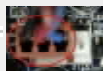

(3ピン CPU\_FAN2)

ページ 4, アイテム 6 を参照

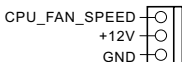

### ATX パワーコネクタ

(24ピン ATXPWR1)

ページ 4, アイテム 7 を参照

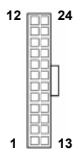

ATX 電源コネクタを接続します。



このマザーボードには 24 ピン ATX 電源コネクタが装備されており、従来の 20 ピン ATX 電源装置を採用している場合でも作動します。20 ピン ATX 電源を使用するには、ピン 1 およびピン 13 と共に電源装置にプラグを差し込みます。

20 ピン ATX 電源装置の取り付け

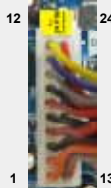



ATX 12V コネクタ  
(8ピン ATX12V1)

ページ 4, アイテム 3 を参照

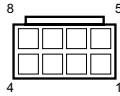

ATX 電 12V 源コネクタを接続します。



このマザーボードで 8-pin ATX 12V 電源コネクタが提供されたが、従来の4-pin ATX 12V 電源でも動作できます。4-pin ATX 電源を使用する場合、電源を Pin 1 と Pin 5 とともに差し込んでください。

4-Pin ATX 12V 電源の取り付け



SLI/XFIRE 電源コネクタ

(4ピン SLI/XFIRE\_POWER1)

ページ 4, アイテム 31 を参照



SLI/XFIRE\_POWER1

このコネクタを使用する必要はありませんが、2つのグラフィックスカードがこのマザーボードに同時に差し込まれているとき、ハードディスクの電源コネクタに接続してください。

IEEE 1394 ヘッド

(9ピン FRONT\_1394)

ページ 4, アイテム 34 を参照

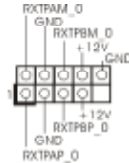

I/O パネルには、デフォルトの1つの IEEE 1394 ポート以外に、このマザーボードに1つの IEEE 1394 ヘッドが搭載されています。それぞれの IEEE 1394 ヘッドは1つの IEEE 1394 ポートをサポートできます。

シリアルポートヘッド

(9ピン COM1)

ページ 4, アイテム 32 を参照

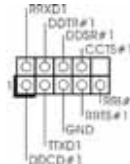

この COM1 ヘッドは、シリアルポートモジュールをサポートします。

HDMI\_SPDIF ヘッド

(2-ピン HDMI\_SPDIF1)

ページ 4, アイテム 33 を参照



HDMI\_SPDIF ヘッドは、SPDIF 音声出力を HDMI VGA カードに提供し、システムで HDMI デジタル TV/プロジェクタ/LCD デバイスに接続できるようにします。HDMI VGA カードの HDMI\_SPDIF コネクタを、このヘッドに接続してください。

## 前面USB 3.0パネルの取り付けガイド

**手順 1** バンドルされた前面 USB 3.0 パネル、4 本の HDD ねじ、6 本のシャーシねじを準備します。



**手順 3** 前面USB 3.0パネルを筐体の2.5インチドライブベイに取り付けます。



**手順 5** 前面USB 3.0ケーブルをマザーボードのUSB3.0ヘッダ(USB3\_5\_6やUSB3\_7\_8)に差し込みます。



**手順 2** 2.5" HDD/SSD を 4 本の HDD ねじで前面 USB 3.0 パネルに取り付けます。



**手順 4** 正面 USB 3.0 パネルを 6 本のシャーシねじでドライブベイに取り付けます。



**手順 6** これで前面USB 3.0パネルの使用準備は完了です。



## 背面USB 3.0ブラケットの取り付けガイド

**手順 1** 前面USB 3.0パネルの2本のネジをはずします。



**手順 3** 背面USB 3.0ブラケットにネジを2本取り付けます。



**手順 2** USB 3.0ケーブルと背面USB 3.0ブラケットを組み立てます。



**手順 4** 背面USB 3.0ブラケットを筐体に取り付けます。



---

## 1.5 クイックスイッチ

マザーボードには、電源スイッチ、リセットスイッチ、および CMOS スイッチをクリアする 3 つのスマートスイッチがあり、ユーザーは、素早く電源のオン / オフ、システムのリセット、または、CMOS 値のクリアを行うことができます。

---

電源スイッチ  
(PWRBTN)

ページ 4、アイテム 18 を参照



電源スイッチはクイックスイッチで、システム電源のオン / オフを素早く切り替えることができます。

---

リセットスイッ

(RSTBTN)

ページ 4、アイテム 19 を参照



リセットスイッはクイックスイッで、システムを素早くリセットすることができます。

---

クリア CMOS スイッ

(CLRBTN)

ページ 5、アイテム 18 を参照



クリア CMOS スイッはクイックスイッで、CMOS 値を素早くクリアできます。

---

## 2. BIOS 情報

BIOS セットアップユーティリティはマザーボードのフラッシュメモリに保存されています。コンピュータを起動させた後、POST(パワーオンセルフテスト)中に〈F2〉または〈Del〉を押し、BIOS セットアップユーティリティに入ってください。押さない場合、POST はテストルーチンを続けます。テストを実行した後に BIOS セットアップユーティリティに入りたい場合、POST 終了後〈Ctrl〉+〈Alt〉+〈Delete〉を押すか、ケースのリセットスイッチを押してシステムを再起動してください。BIOS セットアップユーティリティは、ユーザーフレンドリであることを目指しています。これはメニュー方式のプログラムです。スクロールさせることで様々なサブメニューを表示し、かつあらかじめ定義した選択肢から選択することが可能です。BIOS セットアップの詳細な情報については、サポート CD 内のユーザーズマニュアル (PDF ファイル) をごらんください。

## 3. ソフトウェア サポート CD 情報

このマザーボードは Microsoft® Windows® 7 / 7 64-bit / Vista™ / Vista™ 64-bit / XP / XP 64-bit といった様々なマイクロソフト ウィンドウズ オペレーティングシステムをサポートします。マザーボードに付属しているサポート CD はマザーボードの特徴を有効にするために必要なドライバやユーティリティを含んでいます。サポート CD を使用するには、CDROM ドライブに CD を挿入してください。AUTORUN 機能が有効な場合、自動的にメインメニューが立ち上がります。AUTORUN 機能が無効な場合、サポート CD 内の BIN フォルダにある ASSETUP.EXE をダブルクリックすることにより、メインメニューが立ち上がります。

# 1. 主板简介

谢谢你采用了 **Fatal1ty X79 Professional Series** 主板，本主板由华擎严格制造，质量可靠，稳定性好，能够获得卓越的性能。本安装指南介绍了安装主板的步骤。更加详细的主板信息可参看驱动光盘的用户手册。



由于主板规格和 BIOS 软件将不断升级，本手册之相关内容变更恕不另行通知。请留意华擎网站上公布的升级版本。你也可以在华擎网站找到最新的显卡和 CPU 支持表。

华擎网址：<http://www.asrock.com>

如果您需要与此主板有关的技术支持，请参观我们的网站以了解您使用何种的规格信息。

[www.asrock.com/support/index.asp](http://www.asrock.com/support/index.asp)

## 1.1 包装盒内物品

### **Fatal1ty X79 Professional Series** 主板

(ATX 规格：12.0 英寸 X 9.6 英寸，30.5 厘米 X 24.4 厘米)

### **Fatal1ty X79 Professional Series** 快速安装指南

### **Fatal1ty X79 Professional Series** 支持光盘

六条 Serial ATA(SATA) 数据线 (选配)

两条 Serial ATA(SATA) 硬盘电源线 (选配)

一块 I/O 挡板

一个前置 USB 3.0 面板

四个硬盘螺丝

六个机箱螺丝

一个后部 USB 3.0 面板

两个华擎 SLI\_Bridge 桥接卡

一个华擎 SLI\_Bridge\_3S 桥接卡

一个华擎 3-Way SLI 桥接卡



### **ASRock提醒您...**

为了在 Windows® 7 / 7 64-bit / Vista™ / Vista™ 64-bit 系统中取得更好的性能，建议您在BIOS中将Storage Configuration (存储配置) 选项设成AHCI模式。关于BIOS设置程序，请参见支持光盘中的“User Manual”以了解相详细信息。

## 1.2 主板规格

架构	<ul style="list-style-type: none"> <li>- ATX 规格：12.0 英寸 X 9.6 英寸，30.5 厘米 X 24.4 厘米</li> <li>- 优质镀金电容设计（100% 日制高品质高传导性固态电容）</li> </ul>
处理器	<ul style="list-style-type: none"> <li>- 支持 LGA2011 插槽的 Intel® Core™ i7 处理器家族</li> <li>- 数字脉宽调制设计</li> <li>- 高级 16 + 2 电源相位设计</li> <li>- 支持 Intel® Turbo Boost 2.0 技术</li> <li>- 支持 Hyper-Threading 超线程技术（详见警告 1）</li> <li>- 支持异步超频技术</li> </ul>
芯片组	<ul style="list-style-type: none"> <li>- Intel® X79</li> </ul>
系统内存	<ul style="list-style-type: none"> <li>- 支持四通道 DDR3 内存技术（见警告 2）</li> <li>- 配备四个 DDR3 DIMM 插槽</li> <li>- 支持 DDR3 2400+(超频)/2133(超频)/1866(超频)/1600/1333/1066 non-ECC、un-buffered 内存</li> <li>- Intel® Workstation 1S Xeon® 处理器 E5 16xx/26xx/46xx 系列（LGA 2011 接口）支持 DDR3 ECC 无缓存内存</li> <li>- 最高支持 32GB 系统容量（见警告 3）</li> <li>- 支持 Intel® Extreme Memory Profile(XMP)1.3/1.2</li> </ul>
扩展插槽	<ul style="list-style-type: none"> <li>- 4 x PCI Express 3.0 x16 插槽（PCIe1/PCIe2/PCIe4/PCIe5: x16/8/16/0 模式和 x16/8/8/8 模式）（见警告 4）</li> <li>- 1 x PCI Express 2.0 x1 插槽</li> <li>- 2 x PCI 插槽</li> <li>- 支持 AMD Quad CrossFireX™, 4 路 CrossFireX™, 3 路 CrossFireX™ 和 CrossFireX™ 技术</li> <li>- 支持 NVIDIA® Quad SLI™, 4 路 SLI™, 3 路 SLI™ 和 SLI™ 技术</li> </ul>
音效	<ul style="list-style-type: none"> <li>- 7.1 声道高保真音频，支持内容保护功能（Realtek ALC898 音频编解码器）</li> <li>- 支持优质蓝光音效</li> <li>- 支持 THX TruStudio™</li> </ul>
板载 LAN 功能	<ul style="list-style-type: none"> <li>- PCIe x1 Gigabit LAN 10/100/1000 Mb/s</li> <li>- Broadcom BCM57781</li> <li>- 支持网路唤醒（Wake-On-LAN）</li> <li>- 支持 Energy Efficient Ethernet 802.3az</li> <li>- 支持 PXE</li> </ul>
Rear Panel I/O (后面板输入/ 输出接口)	<p>I/O 界面</p> <ul style="list-style-type: none"> <li>- 1 个 PS/2 键盘接口</li> <li>- 1 个同轴 SPDIF 输出接口</li> <li>- 1 个光纤 SPDIF 输出接口</li> <li>- 5 个可直接使用的 USB 2.0 接口</li> <li>- 1 个 Fatal1ty 鼠标接口（USB 2.0）</li> </ul>

	<ul style="list-style-type: none"> <li>- 2 个 eSATA3 接口</li> <li>- 4 个可直接使用的 USB 3.0 接口</li> <li>- 1 个 RJ-45 局域网接口与 LED 指示灯 (ACT/LINK LED 和 SPEED LED)</li> <li>- 1 个 IEEE 1394 接口</li> <li>- 1 个 CMOS 数据清除开关</li> <li>- 高保真音频插孔: 侧置喇叭 / 后置喇叭 / 中置喇叭 / 低音喇叭 / 音频输入 / 前置喇叭 / 麦克风 (见警告 5)</li> </ul>
SATA3	<ul style="list-style-type: none"> <li>- 2 x Intel® X79 的 SATA3 6.0Gb/s 连接头, 支持 RAID (RAID 0, RAID 1, RAID 5, RAID 10 和 Intel Rapid Storage3.0), NCQ, AHCI 和热插拔功能</li> <li>- 4 x Marvell SE9172 的 SATA3 6.0Gb/s 连接头, 支持 RAID (RAID 0, RAID 1), NCQ, AHCI 和热插拔功能</li> </ul>
USB 3.0	<ul style="list-style-type: none"> <li>- 2 x TI® 的后置 USB 3.0 连接头, 支持 USB 1.0/2.0/3.0 到 5Gb/s</li> <li>- 2 x TI® 的前置 USB 3.0 连接头 (支持 4 个 USB 3.0 接口), 支持 USB 1.0/2.0/3.0 到 5Gb/s</li> </ul>
连接头	<ul style="list-style-type: none"> <li>- 4 x SATA2 3.0Gb/s 连接头, 支持 RAID (RAID 0, RAID 1, RAID 5, RAID 10 和 Intel Rapid Storage3.0), NCQ, AHCI 和热插拔功能</li> <li>- 6 x SATA3 6.0Gb/s 连接头</li> <li>- 1 x 红外线模块接头</li> <li>- 1 x 消费类红外线模块接头</li> <li>- 1 x 串行接口</li> <li>- 1 x HDMI_SPDIF 接头</li> <li>- 1 x IEEE 1394 接头</li> <li>- 1 x 电源指示灯连接排针</li> <li>- CPU/ 机箱 / 电源风扇接头</li> <li>- 24 针 ATX 电源接头</li> <li>- 8 针 12V 电源接头</li> <li>- SLI/XFire 电源接头</li> <li>- 前置音频面板接头</li> <li>- 3 x USB 2.0 接口 (可支持 6 个额外的 USB 2.0 接口)</li> <li>- 2 x USB 3.0 接口 (可支持 4 个额外的 USB 3.0 接口)</li> <li>- 1 x Dr. Debug (7 段调试 LED)</li> </ul>
快速开关	<ul style="list-style-type: none"> <li>- 1 个带 LED 的电源开关</li> <li>- 1 个带 LED 的复位开关</li> <li>- 1 个带 LED 的 CMOS 数据清除开关</li> </ul>
BIOS	<ul style="list-style-type: none"> <li>- 64Mb AMI UEFI Legal BIOS, 支持 GUI</li> <li>- 支持即插即用 (Plug and Play, PnP)</li> <li>- ACPI 1.1 电源管理</li> </ul>

	<ul style="list-style-type: none"> <li>- 支持 jumperfree 免跳线模式</li> <li>- 支持 SMBIOS 2.3.1</li> <li>- CPU, VCCSA, DRAM, VTT, CPU PLL, PCH1.1V, PCH1.5V 电压多功能调节器</li> </ul>
支持光盘	<ul style="list-style-type: none"> <li>- 驱动程序, 工具软件, 杀毒软件 (测试版本), CyberLink MediaEspresso 6.5 试用版, 华擎软件套装 (华擎 MAGIX 多媒体套件 - OEM)</li> </ul>
独家功能	<ul style="list-style-type: none"> <li>- F-Stream (详见警告 6)</li> <li>- 华擎即时开机功能</li> <li>- 华擎 Instant Flash (见警告 7)</li> <li>- 华擎 APP Charger (见警告 8)</li> <li>- 华擎 SmartView (见警告 9)</li> <li>- 华擎 XFast USB (见警告 10)</li> <li>- 华擎 XFast LAN (见警告 11)</li> <li>- 华擎 XFast Charger (见警告 12)</li> <li>- 华擎 XFast RAM (见警告 13)</li> <li>- 华擎 Crashless BIOS (见警告 14)</li> <li>- Hybrid Booster (安心超频技术): <ul style="list-style-type: none"> <li>- 支持 CPU 无级频率调控 (见警告 15)</li> <li>- ASRock U-COP (见警告 16)</li> <li>- Boot Failure Guard (B.F.G., 启动失败恢复技术)</li> </ul> </li> <li>- 晚安指示灯</li> </ul>
硬件监控器	<ul style="list-style-type: none"> <li>- CPU 温度侦测</li> <li>- 主板温度侦测</li> <li>- CPU/ 机箱 / 电源风扇转速计</li> <li>- CPU/ 机箱静音风扇 (允许根据 CPU 温度自动调整机箱风扇速度)</li> <li>- CPU/ 机箱风扇多速控制</li> <li>- 电压范围: +12V, +5V, +3.3V, 核心电压</li> </ul>
操作系统	<ul style="list-style-type: none"> <li>- Microsoft® Windows® 7/7 64 位元 / Vista™ / Vista™ 64 位元 / XP/XP 64 位元适用于此主板 (见警告 17)</li> </ul>
认证	<ul style="list-style-type: none"> <li>- FCC, CE, WHQL</li> <li>- 支持 ErP/EuP (需要同时使用支持 ErP/EuP 的电源供应器) (见警告 18)</li> </ul>

\* 请参阅华擎网站了解详细的产品信息: <http://www.asrock.com>

#### 警告

请了解超频具有不可避免的风险, 这些超频包括调节 BIOS 设置、运用异步超频技术或使用第三方超频工具。超频可能会影响您的系统稳定性, 甚至会导致系统组件和设备的损坏。这种风险和代价须由您自己承担, 我们对超频可能导致的损坏不承担责任。



## 警告！

- 1、关于“Hyper-Threading Technology”（超线程技术）的设置，请参考 CD 光盘中的“User Manual”第 67 页。
- 2、这款主板支援四通道内存技术。在您实现四通道内存技术之前，为能正确安装，请确认您已经阅读了第 18 页的内存模组安装指南。
- 3、由于操作系统的限制，在 Windows® 7 / Vista™ / XP 下，供系统使用的实际内存容量可能小于 4GB。对于 Windows® 操作系统搭配 64 位元 CPU 来说，不会存在这样的限制。您可以通过 ASRock XFast RAM 来利用 Windows® 无法使用的内存。
- 4、目前 Intel® 2011 接口 Sandy Bridge-E 处理器不支持 PCIE 3.0，但此主板已做好支持 PCIE 3.0 硬件的准备。是否能启用 PCIE 3.0 取决于 Intel 的 CPU。有关未来 CPU 更新和发布情况的信息，请访问 Intel 网站。
- 5、在麦克风输入方面，这款主板支持立体声和单声道这两种模式。在音频输出方面，这款主板支持 2 声道、4 声道、6 声道以及 8 声道模式。请查阅第 5 页的表格了解正确的连接方式。
- 6、F-Stream 是一个多合一的工具，可在用户友好的界面中微调不同的系统功能，包括硬件监控、风扇控制、超频、OC DNA 和 IES。在 Hardware Monitor（硬件监控）中，显示系统的主要参数。在 Fan Control（风扇控制）中，显示风扇速度和温度，以便您进行调整。在 Overclocking（超频）中，您可以对 CPU 进行超频，以优化系统性能。在 OC DNA 中，您可以将自己的 OC 设置保存为配置文件，并与您的朋友共享。您的朋友可以将您的 OC 配置文件加载他们的系统中，从而得到相同的 OC 设置。在 IES（智能节能）中，电压调节器可以在 CPU 核心空闲时减少输出相位数，以提高效率且不影响运算性能。
- 7、华擎 Instant Flash 是一个内建于 Flash ROM 的 BIOS 更新工具程序。这个方便的 BIOS 更新工具可让您无需进入操作系统（如 MS-DOS 或 Windows®）即可进行 BIOS 的更新。在系统开机自检过程中按下 <F6> 键或在 BIOS 设置菜单中按下 <F2> 键即可进入华擎 Instant Flash 工具程序。启动这一程序后，只需把新的 BIOS 文件保存在 U 盘、软盘或硬盘中，轻松点击鼠标就能完成 BIOS 的更新，而不再需要准备额外的软盘或其他复杂的更新程序。请注意：U 盘或硬盘必须使用 FAT32/64 文件系统。
- 8、若您想要更快速、更自由地为您的苹果设备，如 iPhone/iPad/iPod touch 充电，华擎为您提供了一个绝妙的解决方案 - 华擎 APP Charger。只需安装 APP Charger 驱动程序，用电脑为 iPhone 充电最多可比以往快 40%。华擎 APP Charger 允许您同时为多部苹果设备快速充电，甚至可以在电脑进入待机 (S1)、挂起至内存 (S3)、休眠 (S4) 或关机 (S5) 模式下持续为设备充电。只需安装了 APP Charger 驱动程序，您立刻就能拥有非凡的充电体验。
- 9、SmartView 是 Internet 浏览器的一项新功能，它作为 IE 的智能起始页面，在一个增强的视图中提供您经常访问的网站、您的浏览历史记录、您的 Facebook 朋友、以及您的实时新闻来源，可为您提供更具个性化的 Internet 体验。华擎主板专门配备 SmartView 应用程序，可帮助您随时与朋友保持联系。为使用 SmartView 功能，请确保您操作系统的版本是 Windows® 7 / 7 64 位元 / Vista™ / Vista™ 64 位元，浏览器的版本是

IE8。

华擎网站: <http://www.asrock.com/Feature/SmartView/index.asp>

- 10、华擎 XFast USB 可以提升 USB 存储设备性能。性能可能因设备特性不同而存在差异。
- 11、华擎 XFast LAN 可提供更快的网络访问, 包括以下诸多好处。网络应用程序优先级: 您可以设置理想的应用程序优先级, 并可以添加新程序。游戏更少延迟: 将在线游戏设置为较高的优先级, 可降低游戏中的延迟。流量定形: 您可以在观看 Youtube 高清视频的同时进行文件下载。实时分析您的数据: 通过状态窗口, 您可以清楚地看到目前正在传输的是哪个数据流。
- 12、华擎 XFast Charger 是一项可让您通过 PC 对移动设备进行充电的最快最好的技术。通过 XFast Charger USB 接口, 用户可在任何时间享受快速充电体验。除了苹果设备外, 该技术也可为符合 BC 1.1 标准的智能设备充电。详情请参考第 35 页的说明。
- 13、ASRock XFast RAM 是 F-Stream 中加入的一项新功能。它能充分利用 Windows® 操作系统 32-bit CPU 无法使用的内存空间。ASRock XFast RAM 可缩短之前访问过的网站的加载时间, 从而加快网络冲浪速度。此外, 它还能提升 Adobe Photoshop 运行的速度高达五倍之多。ASRock XFast RAM 的另一项优势是它能减少访问 SSD 或 HDD 的频次, 从而延长它们的使用寿命。
- 14、ASRock Crashless BIOS 能让用户安心地更新他们的 BIOS, 而不用担心发生故障。如果在 BIOS 更新过程中断电, ASRock Crashless BIOS 会在电源恢复后自动完成 BIOS 更新过程。请注意, BIOS 文件需存放在 USB 盘的根目录中。此功能只支持 USB2.0 端口。
- 15、尽管本主板提供无级频率调控, 但不推荐用户超频使用。不同于标准 CPU 总线频率的非标准频率可能会使系统不稳定, 甚至会损害 CPU 和主板。
- 16、当检测到 CPU 过热问题时, 系统会自动关机。在您重新启动系统之前, 请检查主板上的 CPU 风扇是否正常运转并拔出电源线, 然后再将它插回。为了提高散热性, 在安装 PC 系统时请在 CPU 和散热器之间涂一层导热胶。
- 17、Microsoft® Windows® XP / XP 64-bit 系统不支持 Intel Rapid Storage Technology enterprise 3.0 和 ASRock XFast RAM。
- 18、EuP, 全称 Energy Using Product (能耗产品), 是欧盟用来定义完整系统耗电量的规定。根据 EuP 的规定, 一个完整系统在关机模式下的交流电总消耗必须在 1.00W 以下。为满足 EuP 标准, 您需要同时具备支持 EuP 的主板和支持 EuP 的电源供应器。根据 Intel® 的建议, 支持 EuP 的电源供应器必须满足在 100mA 电流消耗时, 5Vsb 电源效率高于 50%。有关支持 EuP 的电源供应器选择方面的更多细节, 我们建议您咨询电源供应器的制作商。

### 1.3 跳线设置

插图所示的就是设置跳线的方法。当跳线帽放置在针脚上时，这个跳线就是“短接”。如果针脚上没有放置跳线帽，这个跳线就是“开路”。插图显示了一个 3 针脚的跳线，当跳线帽放置在针脚 1 和针脚 2 之间时就是“短接”。



#### 接脚 设定

##### 清除 CMOS

(CLRCMOS1, 3 针脚跳线)  
(见第 4 页第 25 项)



**注意：** CLRCMOS1 允许您清除 CMOS 中的数据。如要清除并将系统参数恢复至默认设置，请关闭计算机，然后从电源插座上拔掉电源线。等待 15 秒后，使用跳线帽将 CLRCMOS1 上的插针 2 和插针 3 短接 5 秒。但是，请勿在更新 BIOS 后立即清除 CMOS。如果需要在更新 BIOS 后立即清除 CMOS，必须在执行 CMOS 清除操作之前，先启动然后关闭系统。请注意，只有取出 CMOS 电池，密码、日期、时间、用户默认配置文件、1394 GUID 和 MAC 地址才会被清除。



清除 CMOS 开关与清除 CMOS 跳线具有相同的功能。

## 1.4 板载接头和接口



板载接头和接口不是跳线。切勿将跳线帽放置在这些接头和接口上。将跳线帽放置在接头和接口上将会导致主板的永久性损坏！

### Serial ATA2 接口

(SATA2\_0\_1: 见第 4 页第 13 项)

(SATA2\_2\_3: 见第 4 页第 12 项)

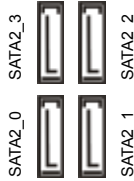

这里有四组 Serial ATA2 (SATA2) 接口支持 Serial (SATA) 数据线作为内部储存设置。目前 SATA2 界面理论上可提供高达 3.0Gb/s 的数据传输速率。

### Serial ATA3 接口

(SATA3\_0\_1: 见第 4 页第 14 项)

(SATA3\_M0\_M1: 见第 4 页第 15 项)

(SATA3\_M2\_M3: 见第 4 页第 16 项)

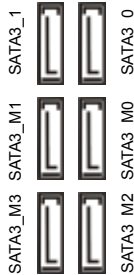

这里有六组 Serial ATA3 (SATA3) 接口支持 Serial (SATA) 数据线作为内部储存设置。目前 SATA3 界面理论上可提供高达 6.0Gb/s 的数据传输速率。

### Serial ATA (SATA) 数据线 (选配)



SATA 数据线的任意一端均可连接 SATA/SATA2/SATA3 硬盘或者主板上的 SATA2/SATA3 接口。

### Serial ATA (SATA) 电源线 (选配)

(选配)



请将 SATA 电源线黑色的一端连接到 SATA 驱动器的电源接口。然后将 SATA 电源线白色的一端连接到电源适配器的电源接口。

### USB 2.0 扩展接头

(9 针 USB\_6\_7)

(见第 4 页第 29 项)

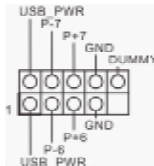

除了位于 I/O 面板的六个默认 USB 2.0 接口之外, 这款主板有三组 USB 2.0 接针。每组 USB 2.0 接针可以支持两个 USB 2.0 接口。

(9 针 USB\_8\_9)  
(见第 4 页第 28 项)

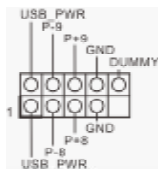

(9 针 USB\_10\_11)  
(见第 4 页第 27 项)

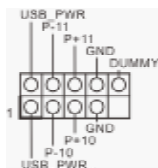

### USB 3.0 扩展接头

(19 针 USB3\_5\_6)  
(见第 4 页第 8 项)

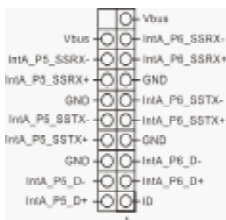

除了位於 I/O 面板的四个默认 USB 3.0 接口之外，这款主板有两组 USB 3.0 接针。每组 USB 3.0 接针可以支持两个 USB 3.0 接口。

(19 针 USB3\_7\_8)  
(见第 4 页第 9 项)

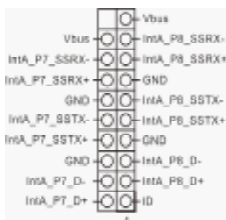

### 红外线模块接头

(5 针 IR1)  
(见第 4 页第 37 项)

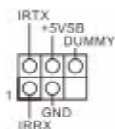

这个接头支持一个选配的无线发送和接收红外线的模块。

### 消费类红外线模块接头

(4 针 CIR1)  
(见第 4 页第 30 项)



此接口可以连接遥控器。

## 前置音频面板接头

(9 针 HD\_AUDIO1)  
(见第 4 页第 35 项)

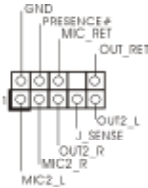

可以方便连接音频设备。



1. 高保真音频 (High Definition Audio, HDA) 支持智能音频接口检测功能 (Jack Sensing), 但是机箱面板的连线必须支持 HDA 才能正常使用。请按我们提供的手册和机箱手册上的使用说明安装您的系统。2. 如果您使用 AC' 97 音频面板, 请按照下面的步骤将它安装到前面板音频接针:

- A. 将 Mic\_IN (MIC) 连接到 MIC2\_L。
- B. 将 Audio\_R (RIN) 连接到 OUT2\_R, 将 Audio\_L (LIN) 连接到 OUT2\_L。
- C. 将 Ground (GND) 连接到 Ground (GND)。
- D. MIC\_RET 和 OUT\_RET 仅用于 HD 音频面板。您不必将它们连接到 AC' 97 音频面板。
- E. 开启前置麦克风。

在 Windows® XP / XP 64 位元操作系统中:

选择“Mixer”。选择“Recorder”。接著点击“FrontMic”。

在 Windows® 7 / 7 64 位元 / Vista™ / Vista™ 64 位元操作系统中:

在 Realtek 控制面板中点击“FrontMic”。调节“Recording Volume”。

## 系统面板接头

(9 针 PANEL1)  
(见第 4 页第 22 项)

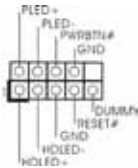

这个接头提供数个系统前面板功能。



根据下面的针脚说明连接机箱上的电源开关、重启按钮与系统状态指示灯到这个排针。根据之前请注意针脚的正负极。

PWRBTN (电源开关):

连接机箱前面板的电源开关。您可以设置用电源键关闭系统的方式。

RESET (重启开关):

连接机箱前面板的重启开关。当电脑死机且无法正常重新启动时,可按下重启开关重新启动电脑。

PLED (系统电源指示灯):

连接机箱前面板的电源状态指示灯。当系统运行时,此指示灯亮起。当系统处于 S1 待机模式时,此指示灯保持闪烁。当系统处于 S3/S4 待机模式或关机 (S5) 模式时,此指示灯熄灭。

HD LED (硬盘活动指示灯):

连接机箱前面板的硬盘动作指示灯。当硬盘正在读取或写入数据时,此指示灯亮起。

前面板设计因机箱不同而有差异。前面板模块一般由电源开关、重启开关、电源指示灯、硬盘动作指示灯、喇叭等构成。将您的机箱前面板连接到此排针时，请确认连接线与针脚上的说明相对应。

### 机箱喇叭接头

(4 针 SPEAKER1)

(见第 4 页第 21 项)

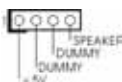

请将机箱喇叭连接到这个接头。

### 电源指示灯连接排针

(3 针 PLED1)

(见第 4 页第 23 项)



请将机箱电源指示灯连接到这一排针，以指示系统电源状态。当系统正在运行时，LED 指示灯亮。在 S1 模式下，LED 指示灯会不停闪烁。在 S3/S4 或 S5 模式（关机）下，LED 指示灯会熄灭。

### 机箱，电源风扇接头

(4 针 CHA\_FAN1)

(见第 4 页第 11 项)

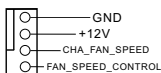

请将风扇连接线接到这个接头，并让黑线与接地的针脚相接。

CHA\_FAN1、CHA\_FAN2 和 CHA\_FAN3 支持风扇控制。

(3 针 CHA\_FAN2)

(见第 4 页第 20 项)

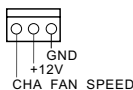

(3 针 CHA\_FAN3)

(见第 4 页第 17 项)

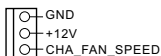

(3 针 PWR\_FAN1)

(见第 4 页第 44 项)

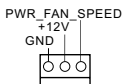

### CPU 风扇接头

(4 针 CPU\_FAN1)

(见第 4 页第 5 项)

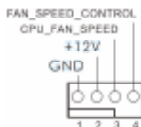

请将 CPU 风扇连接线接到这个接头，让黑线与接地的针脚相接。



虽然此主板支持 4-Pin CPU 风扇 (Quiet Fan, 静音风扇)，但是没有调速功能的 3-Pin CPU 风扇仍然可以在此主板上正常运行。如果您打算将 3-Pin CPU 风扇连接到此主板的 CPU 风扇接口，请将它连接到 Pin 1-3。

Pin 1-3 连接 ←  
3-Pin 风扇的安装

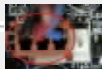

(3 针 CPU\_FAN2)  
(见第 4 页第 6 项)

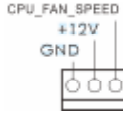

ATX 电源接头  
(24 针 ATXPWR1)  
(见第 4 页第 7 项)

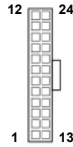

请将 ATX 电源供应器连接到这个接头。



虽然此主板提供 24-pin ATX 电源接口, 但是您仍然可以使用传统的 20-pin ATX 电源。为了使用 20-pin ATX 电源, 请顺著 Pin 1 和 Pin 13 插上电源接头。

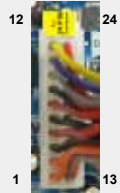

20-Pin ATX 电源安装说明

ATX 12V 接头  
(8 针 ATX12V1)  
(见第 4 页第 3 项)

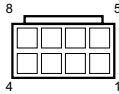

请将一个 ATX 12V 电源供应器连接到这个接头。



虽然此主板提供 8-pin ATX 12V 电源接口, 但是您仍然可以使用传统的 4-pin ATX 12V 电源。为了使用 4-pin ATX 12V 电源, 请顺著 Pin 1 和 Pin 5 插上电源接头。



4-Pin ATX 12V 电源安装说明

SLI/XFIRE 电源接头  
(4 针 SLI/XFIRE\_POWER1)  
(见第 4 页第 31 项)



一般不需要使用这个接口, 但是如果主板上同时插入两块显卡时, 请将它连接到硬盘电源接口。

IEEE 1394 接口  
(9 针 FRONT\_1394)  
(见第 4 页第 34 项)

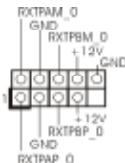

除了位於 I/O 面板的一个默认 IEEE 1394 接口之外, 这款主板有一组 IEEE 1394 接针。这组 IEEE 1394 接针可以支持一个 IEEE 1394 接口。



---

## 串行接口连接器

(9 针 COM1)

(见第 4 页第 32 项)

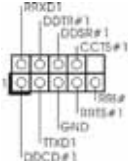

这个 COM1 端口支持一个串行接口的外设。

---

## HDMI\_SPDIF 接头

(2 针 HDMI\_SPDIF1)

(见第 4 页第 33 项)



HDMI\_SPDIF 接头，提供 SPDIF 音频输出至 HDMI 显卡，支持将电脑连接至带 HDMI 的数字电视 / 投影机 / 液晶显示器等设备。请将 HDMI 显卡的 HDMI\_SPDIF 接口连接到这个接头。

## 前部USB 3.0面板安装指南

**步骤 1** 准备好随附的前部 USB 3.0 面板、四个 HDD 螺丝、以及六个机箱螺丝。



**步骤 2** 用四个 HDD 螺丝将 2.5" HDD/SSD 装到前部 USB 3.0 面板上。



**步骤 3** 将前部USB 3.0面板装入机箱的2.5" 驱动器托槽。



**步骤 4** 用六个机箱螺丝将前部USB 3.0面板装入驱动器托槽并拧上螺丝。



**步骤 5** 将前部USB 3.0线插入主板上的USB 3.0接头 (USB3\_5\_6或USB3\_7\_8)。



**步骤 6** 现在，即可使用USB 3.0面板了。



## 后部USB 3.0面板安装指南

**步骤 1** 拧下前部USB 3.0面板上的两个螺丝。



**步骤 3** 将两个螺丝拧入后部USB 3.0面板。



**步骤 2** 将USB 3.0线连接到后部USB 3.0面板。



**步骤 4** 将后部USB 3.0面板装到机箱上。



---

## 1.5 快速开关

本主板有三个快速开关：电源开关，复位开关与 CMOS 数据清除开关，可让用户快速开启 / 关闭或复位系统，或者清除 CMOS 中的数据。

---

### 电源开关

(PWRBTN)

(见第 4 页第 18 项)



电源开关是一种快速开关，可让用户快速开启 / 关闭系统。

---

### 复位开关

(RSTBTN)

(见第 4 页第 19 项)



复位开关是一种快速开关，可让用户快速复位系统。

---

### CMOS 数据清除开关

(CLRBTN)

(见第 5 页第 18 项)



CMOS 数据清除开关是一种快速开关，可让用户快速清除 CMOS 中的数据。

---

## 2. BIOS 信息

主板上的 Flash Memory 存储了 BIOS 设置程序。请再启动电脑进行开机自检 (POST) 时按下 <F2> 或 <Del> 键进入 BIOS 设置程序；此外，你也可以让开机自检 (POST) 进行常规检验。如果你需要在开机自检 (POST) 之后进入 BIOS 设置程序，请按下 <Ctrl>+<Alt>+<Delete> 键重新启动电脑，或者按下系统面板上的重启按钮。有关 BIOS 设置的详细信息，请查阅随机支持光盘里的用户手册 (PDF 文件)。

## 3. 支持光盘信息

本主板支持各种微软视窗操作系统：Microsoft® Windows® 7/7 64 位元 /Vista™/ Vista™ 64 位元 /XP/XP 64 位元。主板随机支持光盘包含各种有助于提高主板效能的必要驱动和实用程序。请将随机支持光盘放入光驱里，如果电脑的“自动运行”功能已启用，屏幕将会自动显示主菜单。如果主菜单不能自动显示，请查找支持光盘内 BIN 文件夹下的“ASSETUP.EXE”，并双击它，即可调出主菜单。

## 电子信息产品污染控制标示

依据中国发布的「电子信息产品污染控制管理办法」及 SJ/T 11364-2006「电子信息产品污染控制标示要求」，电子信息产品应进行标示，藉以向消费者揭露产品中含有的有毒有害物质或元素不致发生外泄或突变从而对环境造成污染或对人身、财产造成严重损害的期限。依上述规定，您可于本产品之印刷电路板上看见图一之标示。图一中之数字为产品之环保使用期限。由此可知此主板之环保使用期限为 10 年。



图一

## 有毒有害物质或元素的名称及含量说明

若您欲了解此产品的有毒有害物质或元素的名称及含量说明，请参照以下表格及说明。

部件名称	有害物质或元素					
	铅 (Pb)	镉 (Cd)	汞 (Hg)	六价铬 (Cr (VI))	多溴联苯 (PBB)	多溴二苯醚 (PBDE)
印刷电路板及电子组件	X	O	O	O	O	O
外部信号连接头及线材	X	O	O	O	O	O

O: 表示该有毒有害物质在该部件所有均质材料中的含量均在 SJ/T 11363-2006 标准规定的限量要求以下。

X: 表示该有毒有害物质至少在该部件的某一均质材料中的含量超出 SJ/T 11363-2006 标准规定的限量要求，然该部件仍符合欧盟指令 2002/95/EC 的规范。

备注：此产品所标示之环保使用年限，系指在一般正常使用状况下。

# 1. 主機板簡介

謝謝你採用了 **Fatal1ty X79 Professional Series** 主機板，本主機板由華擎嚴格製造，品質可靠，穩定性好，能夠獲得卓越的性能。此快速安裝指南包括了主機板介紹和分步驟安裝指導。您可以查看支持光碟裡的使用手冊了解更詳細的資料。



由於主機板規格和 BIOS 軟體將不斷更新，本手冊之相關內容變更恕不另行通知。請留意華擎網站上公布的更新版本。你也可以在華擎網站找到最新的顯示卡和 CPU 支援列表。

華擎網址：<http://www.asrock.com>

如果您需要與此主機板有關的技術支援，請參觀我們的網站以了解您使用機種的規格訊息。

[www.asrock.com/support/index.asp](http://www.asrock.com/support/index.asp)

## 1.1 包裝盒內物品

### **Fatal1ty X79 Professional Series** 主機板

(ATX 規格：12.0 英寸 x 9.6 英寸，30.5 公分 x 24.4 公分)

### **Fatal1ty X79 Professional Series** 快速安裝指南

### **Fatal1ty X79 Professional Series** 支援光碟

六條 Serial ATA(SATA) 數據線 (選配)

兩條 Serial ATA(SATA) 硬碟電源線 (選配)

一塊 I/O 擋板

一個前置 USB 3.0 面板

四個硬碟螺絲

六個機殼螺絲

一個後 USB 3.0 托架

兩張華擎 SLI\_Bridge 卡

一張華擎 SLI\_Bridge\_3S 卡

一張華擎 3-Way SLI Bridge 卡



### **ASRock**提醒您...

若要在 Windows® 7 / 7 64位元 / Vista™ / Vista™ 64位元中發揮更好的效能，建議您將儲存裝置組態中的 BIOS 選項設為 AHCI 模式。有關 BIOS 設定的詳細資訊，請參閱支援光碟中的「使用者手冊」。

## 1.2 主機板規格

架構	<ul style="list-style-type: none"> <li>- ATX 規格： 12.0 英寸 x 9.6 英寸，30.5 公分 x 24.4 公分</li> <li>- 頂級黃金電容器設計（百分百日本製造的高品質導電高分子電容器）</li> </ul>
處理器	<ul style="list-style-type: none"> <li>- 支援 LGA2011 腳位的 Intel® Core™ i7 處理器家族</li> <li>- 數位式脈衝寬度調變設計</li> <li>- 高級 16 + 2 電源相位設計</li> <li>- 支援 Intel® Turbo Boost 2.0 技術</li> <li>- 支援 Hyper-Threading 技術（詳見警告 1）</li> <li>- 支援非同步超頻技術</li> </ul>
晶片組	<ul style="list-style-type: none"> <li>- Intel® X79</li> </ul>
系統記憶體	<ul style="list-style-type: none"> <li>- 支援四通道 DDR3 記憶體技術（見警告 2）</li> <li>- 4 個 DDR3 DIMM 插槽</li> <li>- 支援 DDR3 2400+(超頻)/2133(超頻)/1866(超頻)/1600/1333/1066 non-ECC、un-buffered 記憶體</li> <li>- Intel® Workstation 1S Xeon® 處理器 E5 16xx/26xx/46xx 系列（LGA 2011 接口）支援 DDR3 ECC 無緩存內存</li> <li>- 最高支援 32GB 系統容量（見警告 3）</li> <li>- 支援 Intel® Extreme Memory Profile(XMP)1.3/1.2</li> </ul>
擴充插槽	<ul style="list-style-type: none"> <li>- 4 x PCI Express 3.0 x16 插槽（PCIe1/PCIe2/PCIe4/PCIe5: x16/8/16/0 模式或 x16/8/8/8 模式）（見警告 4）</li> <li>- 1 x PCI Express 2.0 x1 插槽</li> <li>- 2 x PCI 插槽</li> <li>- 支援 AMD Quad CrossFire™, 4-Way CrossFire™, 3-Way CrossFire™ 和 CrossFire™ 技術</li> <li>- 支援 NVIDIA® Quad SLI™, 4-Way SLI™, 3-Way SLI™ 和 SLI™ 技術</li> </ul>
音效	<ul style="list-style-type: none"> <li>- 7.1 聲道高清晰音效，支援內容保護功能（Realtek ALC898 音效編解碼器）</li> <li>- 支援高級藍光音效</li> <li>- 支援 THX TruStudio™</li> </ul>
網路功能	<ul style="list-style-type: none"> <li>- PCIe x1 Gigabit LAN 10/100/1000 Mb/s</li> <li>- Broadcom BCM57781</li> <li>- 支援網路喚醒（Wake-On-LAN）</li> <li>- 支援 Energy Efficient Ethernet 802.3az</li> <li>- 支援 PXE</li> </ul>
Rear Panel I/O （後背板輸入/ 輸出接口）	<p>I/O 界面</p> <ul style="list-style-type: none"> <li>- 1 個 PS/2 鍵盤接口</li> <li>- 1 個同軸 SPDIF 輸出接口</li> </ul>

	<ul style="list-style-type: none"> <li>- 1 個光纖 SPDIF 輸出接口</li> <li>- 5 個可直接使用的 USB 2.0 接口</li> <li>- 1 個 Fatal1ty 滑鼠接口 (USB 2.0)</li> <li>- 2 個 eSATA3 接口</li> <li>- 4 個可直接使用的 USB 3.0 接口</li> <li>- 1 個 RJ-45 區域網接口與 LED 指示燈 (ACT/LINK LED 和 SPEED LED)</li> <li>- 1 個 IEEE 1394 接口</li> <li>- 1 個 CMOS 數據清除開關</li> <li>- 高清晰音效插孔：側置喇叭 / 後置喇叭 / 中置喇叭 / 低音喇叭 / 音效輸入 / 前置喇叭 / 麥克風 (見警告 5)</li> </ul>
SATA3	<ul style="list-style-type: none"> <li>- 2 x Intel® X79 的 SATA3 6.0Gb/s 接頭，支援 RAID (RAID 0, RAID 1, RAID 5, RAID 10 和 Intel Rapid Storage3.0), NCQ, AHCI 和熱插拔功能</li> <li>- 4 x Marvell SE9172 的 SATA3 6.0Gb/s 接頭，支援 RAID (RAID 0, RAID 1), NCQ, AHCI 和熱插拔功能</li> </ul>
USB 3.0	<ul style="list-style-type: none"> <li>- 4 x TI® 的後置 USB 3.0 接頭，支援 USB 1.0/2.0/3.0 到 5Gb/s</li> <li>- 2 x TI® 的前置 USB 3.0 接頭 (支援 4 個 USB 3.0 接頭)，支援 USB 1.0/2.0/3.0 到 5Gb/s</li> </ul>
接頭	<ul style="list-style-type: none"> <li>- 4 x SATA2 3.0Gb/s 接頭，支援 RAID (RAID 0, RAID 1, RAID 5, RAID 10 和 Intel Rapid Storage3.0), NCQ, AHCI 和熱插拔功能</li> <li>- 6 x SATA3 6.0Gb/s 接頭</li> <li>- 1 x 紅外線模組接頭</li> <li>- 1 x 消費性紅外線模組插座</li> <li>- 1 x 序列埠</li> <li>- 1 x HDMI_SPDIF 接頭</li> <li>- 1 x IEEE 1394 接頭</li> <li>- 1 x 電源指示燈接頭</li> <li>- CPU/ 機箱 / 電源風扇接頭</li> <li>- 24 針 ATX 電源接頭</li> <li>- 8 針 12V 電源接頭</li> <li>- SLI/XFire 電源接頭</li> <li>- 前置音效接頭</li> <li>- 3 x USB 2.0 接頭 (可支援 6 個額外的 USB 2.0 接口)</li> <li>- 2 x USB 3.0 接頭 (可支援 4 個額外的 USB 3.0 接口)</li> <li>- 1 x Dr. Debug (7 段顯示器偵錯 LED)</li> </ul>
快速開關	<ul style="list-style-type: none"> <li>- 1 個 LED 電源開關</li> <li>- 1 個 LED 重置開關</li> <li>- 1 個 LED CMOS 數據清除開關</li> </ul>



BIOS	<ul style="list-style-type: none"> <li>- 64Mb AMI UEFI Legal BIOS (支援 GUI)</li> <li>- 支援即插即用 (Plug and Play, PnP)</li> <li>- ACPI 1.1 電源管理</li> <li>- 支援 jumperfree 免跳線模式</li> <li>- 支援 SMBIOS 2.3.1</li> <li>- CPU, VCCSA, DRAM, VTT, CPU PLL, PCH1.1V, PCH1.5V 電壓多功能調節</li> </ul>
支援光碟	<ul style="list-style-type: none"> <li>- 驅動程式, 工具軟體, 防毒軟體 (試用版本), CyberLink MediaEspresso 6.5 試用版, 華擎軟體套餐 (華擎 MAGIX 多媒體套餐 - OEM)</li> </ul>
獨家功能	<ul style="list-style-type: none"> <li>- F-Stream (詳見警告 6)</li> <li>- 華擎即時開機功能</li> <li>- 華擎 Instant Flash (見警告 7)</li> <li>- 華擎 APP Charger (見警告 8)</li> <li>- 華擎 SmartView (見警告 9)</li> <li>- 華擎 XFast USB (見警告 10)</li> <li>- 華擎 XFast LAN (見警告 11)</li> <li>- 華擎 XFast 充電器 (見警告 12)</li> <li>- 華擎 XFast RAM (見警告 13)</li> <li>- 華擎 Crashless BIOS (見警告 14)</li> <li>- Hybrid Booster (安心超頻技術): <ul style="list-style-type: none"> <li>- 支援 CPU 無級頻率調控 (見警告 15)</li> <li>- ASRock U-COP (見警告 16)</li> <li>- Boot Failure Guard (B.F.G., 啟動失敗恢復技術)</li> </ul> </li> <li>- 晚安 LED 指示燈</li> </ul>
硬體監控	<ul style="list-style-type: none"> <li>- CPU 溫度偵測</li> <li>- 主機板溫度偵測</li> <li>- CPU/ 機箱 / 電源風扇轉速計</li> <li>- CPU/ 機箱靜音風扇 (可透過 CPU 溫度自動調節機箱的風扇速度)</li> <li>- CPU/ 機箱風扇多速控制</li> <li>- 電壓範圍: +12V, +5V, +3.3V, 核心電壓</li> </ul>
操作系統	<ul style="list-style-type: none"> <li>- Microsoft® Windows® 7/7 64 位元 / Vista™/Vista™ 64 位元 / XP/XP 64 位元 (見警告 17)</li> </ul>
認證	<ul style="list-style-type: none"> <li>- FCC, CE, WHQL</li> <li>- 支援 ErP/EuP (需要同時使用支援 ErP/EuP 的電源供應器) (見警告 18)</li> </ul>

\* 請參閱華擎網站了解詳細的產品訊息: <http://www.asrock.com>

## 警告

請了解超頻具有不可避免的風險，這些超頻包括調節 BIOS 設置、運用非同步超頻技術或使用第三方超頻工具。超頻可能會影響您的系統穩定性，甚至會導致系統組件和設備的損壞。這種風險和代價須由您自己承擔，我們對超頻可能導致的損壞不承擔責任。

## 警告！

- 1、關於“Hyper-Threading Technology”的設置，請參考 CD 光碟中的“User Manual”第 67 頁。
- 2、這款主機板支援四通道記憶體技術。在您使用四通道記憶體技術之前，為能正確安裝，請確認您已經閱讀了第 18 頁的記憶體安裝指南。
- 3、由於作業系統的限制，在 Windows® 7 / Vista™ / XP 下，供系統使用的實際記憶體容量可能小於 4GB。對於 Windows® 作業系統搭配 64 位元 CPU 來說，不會存在這樣的限制。您可以透過 ASRock XFast RAM 來利用 Windows® 無法使用的內存。
- 4、目前 Intel® 2011 腳位 Sandy Bridge-E 處理器不支援 PCIe 3.0，但此主機板已做好支援 PCIe 3.0 硬體的準備。是否能啟用 PCIe 3.0 取決於 Intel 的 CPU。有關未來 CPU 更新和發布情況的資訊，請訪問 Intel 網站。
- 5、在麥克風輸入方面，這款主機板支援立體聲和單聲道這兩種模式。在音效輸出方面，這款主機板支援 2 聲道、4 聲道、6 聲道以及 8 聲道模式。請參閱第 5 頁的表格瞭解正確的連接方式。
- 6、F-Stream 是一款多合一的工具，易於操作的使用者介面便於微調不同的系統功能（例如：Hardware Monitor、Fan Control、Overclocking、OC DNA 及 IES）。Hardware Monitor 可顯示系統的主要讀數；Fan Control 可顯示並可供您調整風扇速度及溫度；Overclocking 可供您進行 CPU 超頻以獲得最佳系統效能。透過 OC DNA，您可將自己的 OC 設定另存為設定檔並與朋友分享，您的朋友可將此 OC 設定檔上傳到自己的系統中，以取得相同的 OC 設定。透過 IES (Intelligent Energy Saver)，當 CPU 處於閒置狀態時，電壓調整器能降低輸出相位數量以改善效率，並可兼顧運算效能。
- 7、華擎 Instant Flash 是一個內建於 Flash ROM 的 BIOS 更新工具程式。這個方便的 BIOS 更新工具可讓您無需進入操作系統（如 MS-DOS 或 Windows®）即可進行 BIOS 的更新。在系統開機自檢過程中按下 <F6> 鍵或在 BIOS 設置菜單中按下 <F2> 鍵即可進入華擎 Instant Flash 工具程式。啟動這一系列式後，只需把新的 BIOS 文件保存在隨身碟、磁盤或硬碟中，輕鬆點選滑鼠就能完成 BIOS 的更新，而不再需要準備額外的磁碟片或其他複雜的更新程式。請注意：隨身碟或硬碟必須使用 FAT32/64 文件系統。
- 8、若您想要更快速、更自由地為您的蘋果設備，如 iPhone/iPad/iPod touch 充電，華擎為您提供了一個絕妙的解決方案 - 華擎 APP Charger。只需安裝 APP Charger 驅動程式，用電腦為 iPhone 充電最多可比以往快 40%。華擎 APP Charger 讓您可以同時為多部蘋果設備快速充電，甚至可以在電腦進入待命 (S1)、待命 (S3)、休眠 (S4) 或關機 (S5) 模式下持續為設備充電。

只需安裝了 APP Charger 驅動程式，您立刻就能擁有非凡的充電體驗。

- 9、SmartView 是網際網路瀏覽器的新功能，也是 IE 的起始頁面，其中結合了您最常瀏覽的網站、您的記錄、Facebook 朋友和即時新聞摘要，並全數整合在一個更好的檢視中，以提供更貼近您個人使用習慣的網際網路功能。ASRock 主機板獨家配備 SmartView 公用程式，協助您隨時隨地與朋友保持聯繫。若要使用 SmartView 功能，請確定您所使用的作業系統版本為 Windows® 7 / 7 64 位元 / Vista™ / Vista™ 64 位元，而且您的瀏覽器版本是 IE8。  
ASRock 網站：<http://www.asrock.com/Feature/SmartView/index.asp>
- 10、華擎 XFast USB 可提升 USB 儲存裝置的效能（效能可能須視裝置特性而定）。
- 11、華擎 XFast LAN 可提供更快的互聯網連接，包含以下諸多優勢。局域網優先應用：您可以設置理想的優先應用程式，並可以添加新程式。減少遊戲延遲：在設置優先級更高的網路遊戲時，可降低遊戲中的延遲。流量定形：您可以在觀看 Youtube 高解析影片的同時還進行文件下載。及時分析您的數據：透過狀態窗口，您可以清楚地看到目前正在傳輸的是哪個數據流。
- 12、ASRock XFast 充電器是兼具充電效率與速度的科技產品，可協助您透過電腦為行動裝置充電。採用一流的 XFast 充電器 USB 連接埠，保證使用者隨時都能體驗充電的極速快感。除了 Apple 設備外，同時也可為 BC1.1 標準智慧型裝置充電。如需詳細資訊，請參閱第 35 頁。
- 13、ASRock XFast RAM 是 ASRock Extreme Tuning Utility (AXTU) 中加入的一項新功能。它能充分利用 Windows® 操作系統 32-bit CPU 無法使用的內存空間。ASRock XFast RAM 可縮短之前訪問過的網站的讀取時間，從而加快網路瀏覽速度。此外，它還能提升 Adobe Photoshop 執行的速度高達五倍之多。ASRock XFast RAM 的另一項優勢是它能減少使用 SSD 或 HDD 的頻率，從而延長它們的使用壽命。
- 14、ASRock Crashless BIOS 能讓使用者安心地更新他們的 BIOS，而不用擔心發生故障。如果在 BIOS 更新過程中斷電，ASRock Crashless BIOS 會在電源恢復後自動完成 BIOS 更新程序。請注意，BIOS 文件需存放在 USB 的根目錄中。此功能只支援 USB2.0 插槽。
- 15、僅管本主機板提供無級頻率調控，但不推薦用戶超頻使用。不同於標準 CPU 側匯流排頻率的非標準頻率可能會使系統不穩定，甚至會損害 CPU 和主機板。
- 16、當檢測到 CPU 過熱問題時，系統會自動關機。在您重新啟動系統之前，請檢查主機板上的 CPU 風扇是否正常運轉並拔出電源線，然後再將它插回。為了提高散熱性，在安裝 PC 系統時請在 CPU 和散熱器之間塗一層散熱膏。
- 17、Microsoft® Windows® XP / XP 64-bit 系統不支援 Intel Rapid Storage Technology enterprise 3.0 和 ASRock XFast RAM。
- 18、EuP, 全稱 Energy Using Product( 能耗產品 ), 是歐盟用來定義完整系統耗電量的規定。根據 EuP 的規定，一個完整系統在關機模式下的交流電總消耗必須在 1.00W 以下。為符合 EuP 標準，您需要同時具備支援 EuP 的主機板和支援 EuP 的電源供應器。根據 Intel® 的建議，支援 EuP 的電源供應器必須符合在 100mA 電流消耗時，5Vsb 電源效率高於 50%。有關支援 EuP 的電源供應器選擇方面的詳情，我們建議您諮詢電源供應器的製造商。

### 1.3 跳線設置

插圖所示的就是設置跳線的方法。當跳線帽放置在針腳上時，這個跳線就是“短接”。如果針腳上沒有放置跳線帽，這個跳線就是“開路”。插圖顯示了一個3針腳的跳線，當跳線帽放置在針腳1和針腳2之間時就是“短接”。



接腳

設定

#### 清除 CMOS

(CLRCMOS1, 3 針腳跳線)

(見第 4 頁第 25 項)



註： CLRCMOS1 可供您清除 CMOS 中的資料。若要清除及重設系統參數並恢復為預設設定，請先關閉電腦電源，並從電源插座中拔下電源線，等待 15 秒鐘之後，使用跳線帽使 CLRCMOS1 的 pin2 及 pin3 短路 5 秒的時間。但請勿於更新 BIOS 後立即清除 CMOS。如需於更新 BIOS 後立即清除 CMOS，您必須先開機再關機，然後再執行 CMOS 清除操作。請注意，只有在移除 CMOS 電池的情況下，密碼、日期、時間、使用者預設設定檔、1394 GUID 及 MAC 位址才會清除。



Clear CMOS 開關的功能與 Clear CMOS 跳線相同。

## 1.4 接頭



此類接頭是不用跳線帽連接的，請不要用跳線帽短接這些接頭。  
跳線帽不正確的放置將會導致主機板的永久性損壞！

### Serial ATA2 接口

(SATA2\_0\_1: 見第4頁第13項)

(SATA2\_2\_3: 見第4頁第12項)

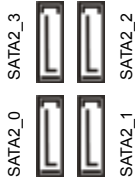

這裡有四組 Serial ATA2

(SATA2) 接口支援 SATA 數據線作為內部儲存設置。目前 SATA2 界面理論上可提供高達 3.0Gb/s 的數據傳輸速率。

### Serial ATA3 接口

(SATA3\_0\_1: 見第4頁第14項)

(SATA3\_M0\_M1: 見第4頁第15項)

(SATA3\_M2\_M3: 見第4頁第16項)



這裡有六組 Serial ATA3

(SATA3) 接口支援 SATA 數據線作為內部儲存設置。目前 SATA3 界面理論上可提供高達 6.0Gb/s 的數據傳輸速率。

### Serial ATA (SATA) 數據線

(選配)



SATA 數據線的任意一端均可連接 SATA/SATA2/SATA3 硬碟或者主機板上的 SATA2/SATA3 接口。

### Serial ATA (SATA) 電源線

(選配)



請將 SATA 電源線黑色的一端連接到 SATA 驅動器的電源接口。然後將 SATA 電源線白色的一端連接到電源适配器的電源接口。

### USB 2.0 擴充接頭

(9 針 USB\_6\_7)

(見第4頁第29項)

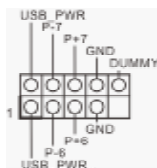

除了位於 I/O 面板的六個 USB 2.0 接口之外，這款主機板有三組 USB 2.0 接針。每組 USB 2.0 接針可以支援兩個 USB 2.0 接口。

(9 針 USB\_8\_9)  
(見第 4 頁第 28 項)

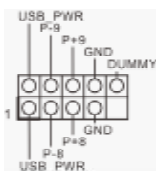

(9 針 USB\_10\_11)  
(見第 4 頁第 27 項)

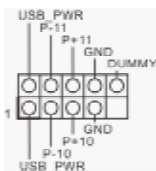

### USB 3.0 擴充接頭

(19 針 USB3\_5\_6)  
(見第 4 頁第 8 項)

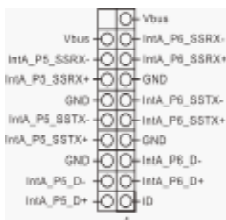

除了位於 I/O 面板的四個 USB 3.0 接口之外，這款主機板有兩組 USB 3.0 接針。每組 USB 3.0 接針可以支援兩個 USB 3.0 接口。

(19 針 USB3\_7\_8)  
(見第 4 頁第 9 項)

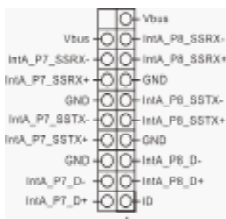

### 紅外線模組接頭

(5 針 IR1)  
(見第 4 頁第 37 項)

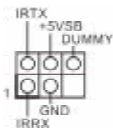

這個接頭支援一個選配的模組，可用來無線傳輸和接收紅外線。

### 消費性紅外線模組插座

(4 針 CIR1)  
(見第 4 頁第 30 項)



此插座可用於連接遙控器。

## 前置音效接頭

(9 針 HD\_AUDIO1)

(見第 4 頁第 35 項)

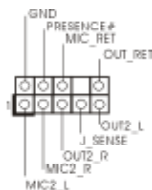

可以方便連接音效設備。



1. 高清晰音效 (High Definition Audio, HDA) 支援智能音效接口檢測功能 (Jack Sensing), 但是機箱面板的連線必須支持 HDA 才能正常使用。請按我們提供的手冊和機箱手冊上的使用說明安裝您的系統。
2. 如果您使用 AC' 97 音效面板, 請按照下面的步驟將它安裝到前面板音效接針:
  - A. 將 Mic\_IN(MIC) 連接到 MIC2\_L。
  - B. 將 Audio\_R(RIN) 連接到 OUT2\_R, 將 Audio\_L(LIN) 連接到 OUT2\_L。
  - C. 將 Ground(GND) 連接到 Ground(GND)。
  - D. MIC\_RET 和 OUT\_RET 僅用於 HD 音效面板。您不必將它們連接到 AC' 97 音效面板。
  - E. 開啟前置麥克風。

在 Windows® XP / XP 64 位元作業系統中:

選擇 "Mixer"。選擇 "Recorder"。接著點選 "FrontMic"。

在 Windows® 7 / 7 64 位元 / Vista™ / Vista™ 64 位元作業系統中:

在 Realtek 控制面板中點選 "FrontMic"。調整 "Recording Volume"。

## 系統面板接頭

(9 針 PANEL1)

(見第 4 頁第 22 項)

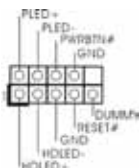

可接各種不同燈, 電源開關及重啟鍵等各種連線。



請根據下面的腳位說明連接機箱上的電源開關、重開按鈕與系統狀態指示燈到這個接頭。請先注意針腳的正負極。

PWRBTN( 電源開關):

連接機箱前面板的電源開關。您可以設定用電源鍵關閉系統的方式。

RESET( 重開開關):

連接機箱前面板的重開開關。當電腦當機且無法正常重新啟動時, 可按下重開開關重新啟動電腦。

PLED( 系統電源指示燈):

連接機箱前面板的電源狀態指示燈。當系統運行時, 此指示燈亮起。當系統處於 S1 待命模式時, 此指示燈保持閃爍。當系統處於 S3/S4 待命模式或關機 (S5) 模式時, 此指示燈熄滅。

HD LED( 硬碟活動指示燈):

連接機箱前面板的硬碟動作指示燈。當硬碟正在讀取或寫入數據時, 此指示燈亮起。

前面板設計因機箱不同而有差異。前面板模組一般由電源開關、重開開關、電源指示燈、硬碟活動指示燈、喇叭等構成。將您的機箱前面板連接到此接頭時，請確認連接線與針腳上的說明相對應。

#### 機箱喇叭接頭

(4 針 SPEAKER)

(見第 4 頁第 21 項)

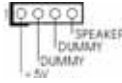

請將機箱喇叭連接到這個接頭。

#### 電源指示燈接頭

(3 針 PLED1)

(見第 4 頁第 23 項)



請將機箱電源指示燈連接到此接頭，以指示系統電源狀態。當系統正在運行時，LED 指示燈亮。在 S1 模式下，LED 指示燈會不停閃爍。在 S3/S4 或 S5 模式（關機）下，LED 指示燈會熄滅。

#### 機箱，電源風扇接頭

(4 針 CHA\_FAN1)

(見第 4 頁第 11 項)

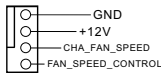

請將風扇連接線接到這個接頭，並讓黑線與接地的針腳相接。

CHA\_FAN1、CHA\_FAN2 和 CHA\_FAN3 支持風扇控制。

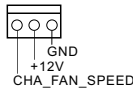

(3 針 CHA\_FAN2)

(見第 4 頁第 20 項)

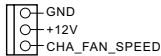

(3 針 CHA\_FAN3)

(見第 4 頁第 17 項)

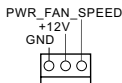

(3 針 PWR\_FAN1)

(見第 4 頁第 44 項)

#### CPU 風扇接頭

(4 針 CPU\_FAN1)

(見第 4 頁第 5 項)

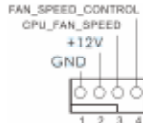

請將 CPU 風扇連接線接到這個接頭，並讓黑線與接地的針腳相接。



雖然此主板支持 4-Pin CPU 風扇（Quiet Fan，靜音風扇），但是沒有調速功能的 3-Pin CPU 風扇仍然可以在此主板上正常運行。如果您打算將 3-Pin CPU 風扇連接到此主板的 CPU 風扇接口，請將它連接到 Pin 1-3。

Pin 1-3 連接  
3-Pin 風扇的安裝

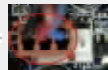



(4 針 CPU\_FAN2)  
(見第 4 頁第 6 項)

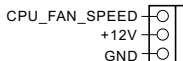

ATX 電源接頭  
(24 針 ATXPWR1)  
(見第 4 頁第 7 項)

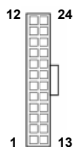

請將 ATX 電源供應器連接到這個接頭。



雖然此主機板提供 24-pin ATX 電源接口，但是您仍然可以使用傳統的 20-pin ATX 電源。為了使用 20-pin ATX 電源，請順著 Pin 1 和 Pin 13 插上電源接頭。

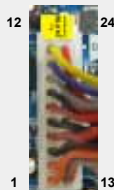

20-Pin ATX 電源安裝說明

ATX 12V 電源接口  
(8 針 ATX12V1)  
(見第 4 頁第 3 項)

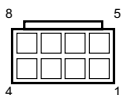

請將 ATX 12V 電源供應器連接到這個接頭。



雖然此主機板提供 8-pin ATX 12V 電源接口，但是您仍然可以使用傳統的 4-pin ATX 12V 電源。為了使用 4-pin ATX 12V 電源，請順著 Pin 1 和 Pin 5 插上電源接頭。



4-Pin ATX 12V 電源安裝說明

SLI/XFIRE 電源接頭  
(4 針 SLI/XFIRE\_POWER1)  
(見第 4 頁第 31 項)



SLI/XFIRE\_POWER1

一般不需要使用這個接頭，但是如果主機板上同時插入兩張顯示卡時，請將它連接到硬碟電源接口。

IEEE 1394 接口  
(9 針 FRONT\_1394)  
(見第 4 頁第 34 項)

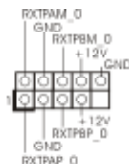

除了位於 I/O 面板的一個默認 IEEE 1394 接口之外，這款主機板有一組 IEEE 1394 接針。這組 IEEE 1394 接針可支援一個 IEEE 1394 接口。

---

### 序列埠

(9 針 COM1)

(見第 4 頁第 32 項)

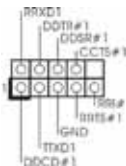

這個序列埠 COM1 支援一個序列埠的裝置。

---

### HDMI\_SPDIF 接頭

(2 針 HDMI\_SPDIF1)

(見第 4 頁第 33 項)



HDMI\_SPDIF 接頭，提供 SPDIF 音效輸出至 HDMI 顯示卡，支援將電腦連接至帶 HDMI 的數位電視 / 投影機 / 液晶銀幕等設備。請將 HDMI 顯示卡的 HDMI\_SPDIF 接口連接到這個接頭。

## 前USB 3.0面板安裝指南

**步驟 1** 備妥搭售的 USB 3.0 前面板、四顆硬碟螺絲及六顆機殼螺絲。



**步驟 3** 將前USB 3.0面板裝入底座的 2.5 吋磁碟機槽中。



**步驟 5** 將前USB 3.0纜線插入主機板上的USB 3.0座 (USB3\_5\_6或USB3\_7\_8)。



**步驟 2** 用四顆硬碟螺絲，將 2.5" 硬碟／固態硬碟鎖至 USB 3.0 前面板上。



**步驟 4** 用六顆機殼螺絲，將 USB 3.0 前面板鎖至硬碟機槽內。



**步驟 6** 前USB 3.0面板隨即可供使用。



## 後USB 3.0托架安裝指南

**步驟 1** 鬆開前USB 3.0面板上的兩顆螺絲。



**步驟 3** 將兩顆螺絲鎖回後USB 3.0托架。



**步驟 2** 將USB 3.0纜線和後USB 3.0托架放在一起。



**步驟 4** 將後USB 3.0托架放入底座中。



---

## 1.5 快速開關

本主機板有三個快速開關：電源開關，重置開關與 CMOS 數據清除開關，可讓用戶快速開啟 / 關閉或重置系統，或者清除 CMOS 中的數據。

---

### 電源開關

(PWRBTN)

(見第 4 頁第 18 項)



電源開關是一種快速開關，可讓用戶快速開啟 / 關閉系統。

---

### 重置開關

(RSTBTN)

(見第 4 頁第 19 項)



重置開關是一種快速開關，可讓用戶快速重置系統。

---

### CMOS 數據清除開關

(CLRCBTN)

(見第 5 頁第 18 項)



CMOS 數據清除開關是一種快速開關，可讓用戶快速清除 CMOS 中的數據。

---

## 2. BIOS 訊息

主板上的 Flash Memory 晶片存儲了 BIOS 設置程序。啟動系統，在系統開機自檢 (POST) 的過程中按下 <F2> 或 <Del> 鍵，就可進入 BIOS 設置程序，否則將繼續進行開機自檢之常規檢驗。如果需要在開機自檢後進入 BIOS 設置程序，請按下 <Ctl> + <Alt> + <Delete> 鍵重新啟動電腦，或者按下系統面板上的重開按鈕。功能設置程序儲存有主板自身的和連接在其上的設備的缺省和設定的參數。這些訊息用於在啟動系統和系統運行需要時，測試和初始化元件。有關 BIOS 設置的詳細訊息，請查閱隨機支援光碟裡的使用手冊 (PDF 文件)。

## 3. 支援光碟訊息

本主板支援各種微軟 Windows<sup>®</sup> 操作系統：Microsoft<sup>®</sup> Windows<sup>®</sup> 7/7 64 位元 / Vista<sup>™</sup>/Vista<sup>™</sup> 64 位元 / XP/XP 64 位元。主板附帶的支援光碟包含各種有助於提高主板效能的必要驅動和實用程式。請將隨機支援光碟放入光碟機裡，如果系統的“自動運行”功能已啟用，銀幕將會自動顯示主菜單。如果主菜單不能自動顯示，請查閱支援光碟內 BIN 文件夾下的 ASSETUP.EXE 文件並雙點它，即可調出主菜單。

---

# 1. Penjelasan

Terima kasih telah membeli motherboard **Fatal1ty X79 Professional Series**, motherboard andal yang diproduksi berdasarkan kontrol kualitas tinggi ASRock secara konsisten. Motherboard ini memberikan performa terbaik dengan desain yang kokoh sesuai komitmen ASRock untuk kualitas dan daya tahan.

Panduan Pemasangan Ringkas ini berisi pendahuluan tentang motherboard dan panduan pemasangan langkah demi langkah. Informasi lengkap lainnya tentang motherboard ini tersedia di buku panduan yang diberikan bersama Support CD (CD Pendukung).



Karena spesifikasi papan induk dan software BIOS barangkali dapat diperbarui, isi dalam buku pedoman ini akan mengikuti perubahan tanpa peringatan. Dalam kondisi terjadinya modifikasi buku pedoman ini, versi baru akan diperlihatkan dalam website ASRock tanpa peringatan lebih. Anda dapat mendapatkan kartu- kartu yang paling baru dan daftar bantuan CPU pada website ASRock.  
Website ASRock <http://www.asrock.com>

## 1.1 Isi Paket

Papan Induk **Fatal1ty X79 Professional Series**

(Faktor Form ATX: 12.0-in x 9.6-in, 30.5 cm x 24.4 cm)

Pemimpin Instalasi Cepat **Fatal1ty X79 Professional Series**

Support CD **Fatal1ty X79 Professional Series**

6 x Kabel satu serial Data ATA (SATA) (bebas-pilih)

2 x Kabel Power Satu Serial ATA (SATA) HDD (bebas-pilih)

1 x Satu Pelindung I/O

1 x Front USB 3.0 Panel

4 x HDD Sekrup

6 x Casis Sekrup

1 x Belakang USB 3.0 golongan

2 x Kartu ASRock SLI\_Bridge

1 x Kartu ASRock SLI\_Bridge\_3S

1 x Kartu ASRock 3-Way SLI Bridge



### **ASRock Mengingatkan...**

Untuk mendapatkan performa lebih baik di Windows® 7/ 64-bit/ Vista™/ Vista™ 64-bit, sebaiknya atur pilihan BIOS dalam Storage Configuration (Konfigurasi Penyimpanan) ke mode AHCI. Untuk konfigurasi BIOS, lihat "Panduan Pengguna" dalam CD dukungan kami untuk informasi rinci.

## 1.2 Spesifikasi

<b>Podium</b>	<ul style="list-style-type: none"> <li>- Faktor Form ATX: 12.0-in x 9.6-in, 30.5 cm x 24.4 cm</li> <li>- Desain Kapasitor Warna Emas Premium (100% Kapasitor Polimer Konduktif buatan Jepang berkualitas tinggi)</li> </ul>
<b>CPU</b>	<ul style="list-style-type: none"> <li>- Mendukung kelompok prosesor Intel® Core™ i7 untuk Soket LGA 2011</li> <li>- Digi Power Desain</li> <li>- Desain Daya 16 + 2 Fase</li> <li>- Menggunakan Teknologi Intel® Turbo Boost 2.0</li> <li>- Menggunakan Teknologi Hyper-Threading</li> <li>- Mendukung Teknologi Untied Overclocking</li> </ul>
<b>Grup Chip</b>	<ul style="list-style-type: none"> <li>- Intel® X79</li> </ul>
<b>Ingatan</b>	<ul style="list-style-type: none"> <li>- Teknologi Memori Quad Channel DDR3</li> <li>- 4 x Alur DDR3 DIMM</li> <li>- Mendukung memori DDR3 2400+(OC)/2133(OC)/1866(OC)/1600/1333/1066 non-ECC yang tidak di-buffer</li> <li>- Mendukung DDR3 ECC, memori tanpa buffer dengan prosesor Intel® Workstation 1S Xeon® E5 16xx/26xx/46xx series di soket LGA 2011</li> <li>- Kapasitas paling banyak: 32GB</li> <li>- Mendukung Intel® Extreme Memory Profile (XMP) 1.3/1.2</li> </ul>
<b>Alur Ekspansi</b>	<ul style="list-style-type: none"> <li>- 4 x PCI Express 3.0 x16 slots (PCIE1/PCIE2/PCIE4/PCIE5: x16/8/16/0 mode; x16/8/8/8 mode)</li> <li>- 1 x PCI Express 2.0 x1 slot</li> <li>- 2 x Alur PCI</li> <li>- Mendukung AMD Quad CrossFireX™, 4-Way CrossFireX™, 3-Way CrossFireX™ dan CrossFireX™</li> <li>- Mendukung NVIDIA® Quad SLI™, 4-Way SLI™, 3-Way SLI™ dan SLI™</li> </ul>
<b>Audio</b>	<ul style="list-style-type: none"> <li>- 7.1 CH HD Audio dengan Content Protection (Realtek ALC898 Audio Codec)</li> <li>- Menggunakan Premium Blu-ray audio</li> <li>- Menggunakan THX TruStudio™</li> </ul>
<b>LAN</b>	<ul style="list-style-type: none"> <li>- PCIE x1 Gigabit LAN 10/100/1000 Mb/s</li> <li>- Broadcom BCM57781</li> <li>- Menggunakan Wake-On-LAN</li> <li>- Mendukung Energy Efficient Ethernet 802.3az</li> <li>- Mendukung PXE</li> </ul>
<b>Papan Belakang I/O</b>	<ul style="list-style-type: none"> <li>I/O Panel</li> <li>- 1 x Port Keyboard PS/2</li> </ul>

	<ul style="list-style-type: none"> <li>- 1 x Port keluaran Coaxial SPDIF</li> <li>- 1 x Port Keluaran Optical SPDIF</li> <li>- 5 x Port USB 2.0 siap-dipakai</li> <li>- 1 x Port Mouse USB Fatal1ty (USB 2.0)</li> <li>- 2 x Port eSATA3</li> <li>- 4 x Port USB 3.0 siap-dipakai</li> <li>- 1 x RJ-45 LAN Port LED (ACT/LINK LED dan SPEED LED)</li> <li>- 1 x Port IEEE 1394</li> <li>- 1 x Tombol Clear CMOS dengan LED</li> <li>- HD Audio Jack: Penyuar Belakang/Pusat/Bass/Line in/ Penyuar Depan/mikropon</li> </ul>
<b>SATA3</b>	<ul style="list-style-type: none"> <li>- 2 x penghubung Intel® X79 SATA3 6.0Gb/s, dapat digunakan RAID (RAID 0, RAID 1, RAID 5, RAID 10 dan Intel Rapid Storage3.0), NCQ, AHCI dan fungsi fungsi "Hot Plug"</li> <li>- 4 x penghubung Marvell SE9172 SATA3 6.0Gb/s, dapat digunakan RAID (RAID 0, RAID 1), NCQ, AHCI dan fungsi fungsi "Hot Plug"</li> </ul>
<b>USB 3.0</b>	<ul style="list-style-type: none"> <li>- 4 x Port Belakang USB 3.0 dari TI®, mendukung USB 1.0/2.0/3.0 hingga 5Gb/s</li> <li>- 2 x Depan USB 3.0 header dari TI® (menggunkan 4 port USB 3.0), mendukung USB 1.0/2.0/3.0 hingga 5Gb/s</li> </ul>
<b>Penghubung</b>	<ul style="list-style-type: none"> <li>- 4 x penghubung SATA2 3.0Gb/s, dapat menggunakan RAID (RAID 0, RAID 1, RAID 5, RAID 10 dan Intel Rapid Storage3.0), NCQ, AHCI dan fungsi "Hot Plug"</li> <li>- 6 x penghubung SATA3 6.0Gb/s</li> <li>- 1 x IR header</li> <li>- 1 x CIR header</li> <li>- 1 x port header COM</li> <li>- 1 x HDMI_SPDIF header</li> <li>- 1 x IEEE 1394 header</li> <li>- 1 x header power LED</li> <li>- Penghubung KIPAS CPU/casis/power</li> <li>- Penghubung power 24 pin ATX</li> <li>- Penghubung power 8 pin 12V</li> <li>- Penghubung power SLI/XFire</li> <li>- Penghubung audio panel dapan</li> <li>- 3 x USB 2.0 header (menggunkan 6 port USB 2.0)</li> <li>- 2 x USB 3.0 header (menggunkan 4 port USB 3.0)</li> <li>- 1 x Dr. Debug</li> </ul>
<b>Beralih</b>	<ul style="list-style-type: none"> <li>- 1 x kuasa beralih LED</li> </ul>



	<ul style="list-style-type: none"> <li>- 1 x ulang beralih LED</li> <li>- 1 x Clear CMOS LED</li> </ul>
<b>Ciri-ciri BIOS</b>	<ul style="list-style-type: none"> <li>- 64Mb AMI UEFI Legal BIOS dengan dukungan GUI</li> <li>- Menggunakan "Plug and Play"</li> <li>- ACPI 1.1 Compliance Wake Up Events</li> <li>- Menggunakan jumperfree</li> <li>- Penyokong AMBIOS 2.3.1</li> <li>- Penyesuaian berbagai tegangan CPU, VCCSA, DRAM, VTT, CPU PLL, PCH1.1V, PCH1.5V</li> </ul>
<b>Sokongan CD</b>	<ul style="list-style-type: none"> <li>- Driver, Utilitas, Perangkat Lunak Antivirus (Versi Percobaan), CyberLink MediaEspresso 6.5 Versi Percobaan, ASRock Software Suite (ASRock MAGIX Multimedia Suite - OEM)</li> </ul>
<b>Fitur Unik</b>	<ul style="list-style-type: none"> <li>- F-Stream</li> <li>- ASRock Instant Boot</li> <li>- ASRock Instant Flash</li> <li>- ASRock APP Charger</li> <li>- ASRock SmartView</li> <li>- ASRock XFast USB</li> <li>- ASRock XFast LAN</li> <li>- ASRock XFast Charger</li> <li>- ASRock XFast RAM</li> <li>- ASRock Crashless BIOS</li> <li>- Hybrid Booster: <ul style="list-style-type: none"> <li>- Kontrol tanpa langkah Frekwensi CPU</li> <li>- ASRock U-COP</li> <li>- Penjaga kegagalan input (B.F.G.)</li> </ul> </li> <li>- Good Night LED</li> </ul>
<b>Penjaga Hardware</b>	<ul style="list-style-type: none"> <li>- Perasa Suhu CPU</li> <li>- Perasa Suhu Casis</li> <li>- Pengukur Kipas CPU/casis/power</li> <li>- Kipas CPU/Sasis Senyap (Kecepatan Kipas Sasis Otomatis Disesuaikan Berdasarkan Temperatur CPU)</li> <li>- Kontrol Multi-Kecepatan Kipas CPU/casis</li> <li>- Penjagaan voltasi: +12V, +5V, +3.3V, Vcore</li> </ul>
<b>OS</b>	<ul style="list-style-type: none"> <li>- dapat digunakan Microsoft® Windows® 7 / 7 64-bit / Vista™ / Vista™ 64-bit / XP / XP 64-bit</li> </ul>
<b>Sertifikasi</b>	<ul style="list-style-type: none"> <li>- FCC, CE, WHQL</li> <li>- ErP/EuP Ready (memerlukan catu daya ErP/EuP ready)</li> </ul>

\* Untuk informasi rinci, silakan kunjungi website kami: <http://www.asrock.com>

---

## Installing OS on a HDD Larger Than 2TB

This motherboard adopts UEFI BIOS that allows Windows® OS to be installed on a large size HDD (>2TB). Please follow the procedures below to install the operating system.

1. Please make sure to use **Windows® Vista™ 64-bit (with SP1 or above)** or **Windows® 7 64-bit**.
2. Press <F2> or <Delete> at system POST. Set **AHCI Mode** in UEFI Setup Utility > Advanced > Storage Configuration > SATA Mode.
3. Choose the item “**UEFI:xxx**” to boot in UEFI Setup Utility > Boot > Boot Option #1. (“xxx” is the device which contains your Windows® installation files. Normally it is an optical drive.) You can also press <F11> to launch boot menu at system POST and choose the item “**UEFI:xxx**” to boot.
4. Start Windows® installation.

---

## Installing OS on a HDD Larger Than 2TB in RAID Mode

This motherboard adopts UEFI BIOS that allows Windows® OS to be installed on a large size HDD (>2TB). Please follow the procedures below to install the operating system.

1. Please make sure to use **Windows® Vista™ 64-bit (with SP1 or above)** or **Windows® 7 64-bit**.
2. Copy Intel® RAID drivers into a USB flash disk. You can download the driver from ASRock's website and unzip the file into a USB flash disk **OR** copy the file from ASRock motherboard support CD. (please copy the files under the following directory:  
**32 bit:** ..\i386\Win7\_Vista\_Intel\_v3.0.0.1112  
**64-bit:** ..\AMD64\Win7-64\_Vista64\_Intel\_v3.0.0.1112
3. Create a RAID array for you system. Please refer to "Intel RAID Installation Guide" file for details.
4. Install Windows® Vista™ 64-bit / 7 64-bit:
  - A. Insert your Windows® Vista™ 64-bit / 7 64-bit installation disc to the optical drive.
  - B. Press <F11> to launch boot menu at system POST and choose the item "UEFI:xxx" to boot.
  - C. Start Windows® Installation. When you see "Where do you want to install Windows?" page, please click "Load Driver".

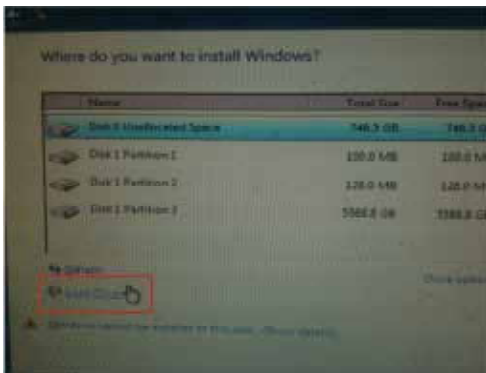

- D. Plug the USB flash disk into your USB port; select "Browse" to find the RAID driver. Then choose the directory (xx\AMD64) you have copied in the first step.

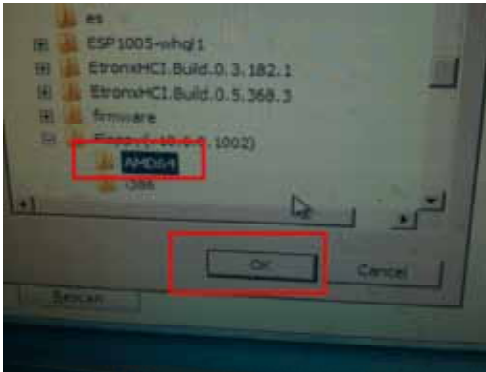

E. Please keep the USB flash disk installed until the system first reboot.

F. Continue to install OS by following the Windows® instructions.

5. Follow Windows® Installation Guide to install OS.

If you install Windows® 7 64-bit / Vista™ 64-bit in a large hard disk (ex. Disk volume > 2TB), it may take more time to boot into Windows® or install driver/utilities. If you encounter this problem, you will need to following instructions to fix this problem.

#### **Windows® Vista™ 64-bit:**

Microsoft® does not provide hotfix for this problem. The steps listed below are Microsoft®'s suggested solution:

A. Disable System Restore.

a. Type "systempropertiesprotection" in the Start Menu. Then press "Enter".

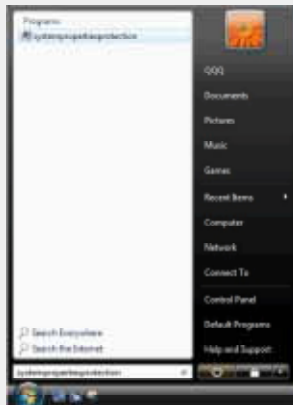

b. De-select Local Disks for System Restore. Then Click "Turn System Restore Off" to confirm. Then Press "Ok".

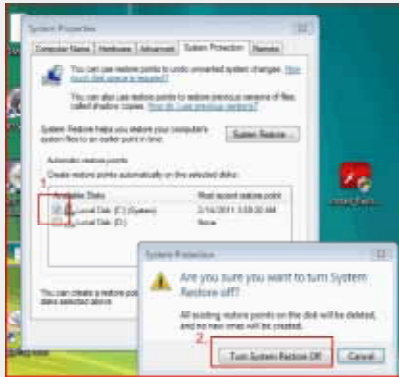

B. Disable “Volume Shadow Copy” service.

a. Type “computer management” in the Start Menu, then press “Enter”.

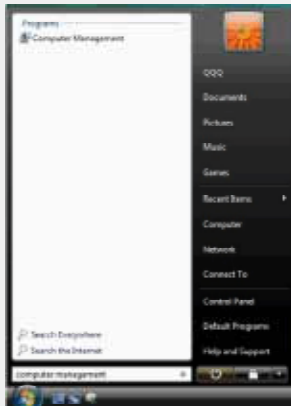

b. Go to “Services and Applications>Services”; Then double click “Volume Shadow Copy”.

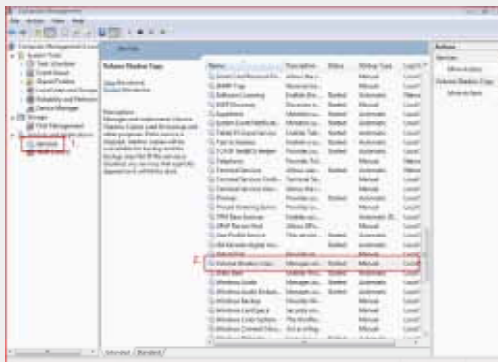

c. Set “Startup type” to “Disable” then Click “OK”.

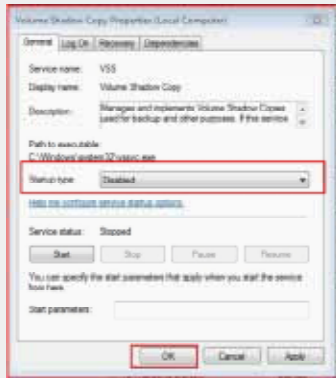

C. Reboot your system.

D. After reboot, please start to install motherboard drivers and utilities.

#### **Windows® 7 64-bit:**

A. Please request the hotfix KB2505454 through this link:

<http://support.microsoft.com/kb/2505454/>

B. After installing Windows® 7 64-bit, install the hotfix kb2505454.  
(This may take a long time; >30 mins.)

C. Reboot your system. (It may take about 5 minutes to reboot.)

D. Windows® will install this hotfix then reboot by itself.

E. Please start to install motherboard drivers and utilities.

6. Finish.