

Operations Manual For Medfusion 2010 Syringe Pump

(Software Versions 1.2 and 1.2A*)*

* **NOTE:** The software version on the pump may display a third digit that is consistent with a software update that does not affect the operation of the pump and is invisible to the user. Please call Medex if the first or second digit on the pump does not correspond to this manual.

This product is compliant with the requirements for Electromagnetic Compatibility (EN60601-1-2) per Council Directive 89/336/EEC. The CE mark is applied to this product when destined for Europe to indicate compliance.

© 1996 Medex, Inc.
All rights reserved.
4025 Blanding Blvd.
Jacksonville, FL 32218
Telephone: 904-424-4400

P/N 9-61-20100-0-3
REVISION 3
OCTOBER, 1996

2010 OPERATIONS MANUAL

1. The first part of the document discusses the importance of maintaining accurate records for all transactions, including sales, purchases, and expenses. This section emphasizes the need for consistency and thoroughness in record-keeping to ensure the integrity of the financial data.

2. The second part of the document outlines the various methods used to collect and analyze data, including surveys, interviews, and focus groups. It details the design of the research instruments and the procedures for data collection and analysis, highlighting the challenges and limitations of each method.

3. The third part of the document presents the results of the study, including the frequency and distribution of responses, the mean and standard deviation of key variables, and the correlations between different variables. This section includes tables and figures to illustrate the findings and provides a detailed interpretation of the results.

4. The fourth part of the document discusses the implications of the findings for theory and practice, highlighting the contributions of the study to the existing literature and the potential applications of the findings in real-world settings. It also addresses the limitations of the study and suggests directions for future research.

1. The first part of the document discusses the importance of maintaining accurate records for all transactions, including sales, purchases, and expenses. This section emphasizes the need for consistency and thoroughness in record-keeping to ensure the integrity of the financial data.

TABLE OF CONTENTS

		Page
SECTION I	INTRODUCTION	1-2
SECTION II	GENERAL SPECIFICATIONS	3-4
SECTION III	GENERAL DESCRIPTION/DIAGRAM	5
SECTION IV	OPERATING INSTRUCTIONS	6-13
SECTION V	USER MODES	14-40
	<i>Body-Weight Mode</i>	14-22
	<i>Mass Mode - MG/HR</i>	23-29
	<i>Continuous Mode - ML/HR</i>	30-35
	<i>Volume/Time Mode</i>	36-40
SECTION VI	PROGRAMMING/OPERATING FEATURES WITH MULTIMODE APPLICATION	41-46
	<i>Bolus Delivery</i>	41-42
	<i>Change Rate</i>	43
	<i>Prime</i>	44
	<i>Standby Mode</i>	45-46
SECTION VI	OTHER KEY FUNCTIONS	47
SECTION VIII	ALARMS/ALERTS	48-52
	TABLE 1	52
SECTION IX	BATTERY POWER	53
SECTION X	BATTERY VOLTAGE	54
SECTION XI	IV POLE OR RAIL ATTACHMENT	55-56
SECTION XII	PRECAUTIONS	57-59
SECTION XIII	CLEANING	60
SECTION XIV	SERVICE AND LIMITED WARRANTY	61-62
APPENDIX I	FLOW RATES	63
APPENDIX II	CALCULATIONS	64-65
APPENDIX III	DEFINITIONS	66-67
APPENDIX IV	CUSTOM PROGRAM MODE	68-74
APPENDIX V	USE OF B-D® LUER LOCK SYRINGES IN THE OPERATION MODE	75

1880

SECTION I

INTRODUCTION

The Medfusion 2010 syringe pump provides continuous, bolus, or intermittent delivery whenever meticulous low volume drug or fluid injections using a syringe are required in the hospital. In the body weight mode, the pump may be programmed to deliver in mcg/kg/min, mcg/kg/HR, MG/kg/min, and MG/kg/HR. Other infusion modes may also be programmed (e.g., MG/HR, ml/HR and volume over time). All medications should be delivered in accordance with their approved drug labeling.

IMPORTANT: Clinical discretion should guide the use of this syringe pump and associated disposables. Considerations should include, but not be limited to, the medication or fluid to be administered, its stability, its compatibility, and its pharmacologic response to environmental conditions. Consult with the syringe manufacturer, medical literature, drug package inserts and other available sources for additional information on syringe/medication interactions.



CAUTION

In consideration of how syringe pumps operate, clinicians should consider use of appropriate syringe, tubing, and in-line devices for the given application and the drug being infused. Certain factors enhance multiple characteristics of syringe pump infusion such as time to detect an occlusion, visual verification of volume delivered, continuity of flow, time to reach the set rate. Following are considerations requiring discretion by clinicians using syringe pumps. (Typically, this is most important with continuous injections of short half-life drugs.)

- a. Select the smallest syringe size appropriate for the intended application. Friction within the syringe (between the plunger rubber tip and the barrel) can affect the continuity of flow and the time required to attain the set infusion rate; the plunger tip expands and relaxes throughout the infusion, particularly with larger syringes at slower rates. The best case is to use smaller syringes at higher rates.
- b. Do not use a 60 cc syringe for rates of 2.0 cc/hour or less. Such use is generally not recommended when using a syringe pump.
- c. Connect the syringe pump tubing at the closest point to the patient for more predictable and accurate delivery of the fluid.
- d. Use small internal diameter, high durometer (hardness) tubing and no in-line devices for best results at low rates.

INTRODUCTION



CAUTION:

Federal (USA) law restricts this device to the sale by or on the order of a physician.



WARNING:

Carefully read the entire contents of this manual, including the "PRECAUTIONS SECTION", before attempting to use your Medfusion 2010 Pump, and verify that the SOFTWARE VERSION of the pump and manuals are in agreement.

The 2010 has four infusion modes: body-weight, milligrams per hour, milliliters per hour and volume over time.

1. *Body Weight Mode where mass units (e.g., mg or mcg) are delivered per weight (e.g., kg) per time (e.g., minute or hour). Rates for this mode would be programmed in mg per kilogram per minute or per hour and mcg per kilogram per minute or hour.*
2. *Mass Mode where mass units (e.g., mg) are delivered per time (e.g., hour). Rates for this example would be programmed in mg per hour.*
3. *Continuous Mode where volume (e.g., ml) is delivered per time (e.g., hour). Rates for this example would be programmed in ml per hour.*
4. *Volume over Time Mode where the total delivery volume in ml and the desired delivery time in hours and minutes are programmed individually.*

SECTION II

GENERAL SPECIFICATIONS

Overall Size	4.5" wide X 3.0" high X 7.5" long
Weight	2.5 pounds
Accuracy	± 3%, excluding syringe variations
Infusion Modes (can be field customized)	<u>Body Weight Modes:</u> mcg/kg/min mcg/kg/HR MG/kg/min MG/kg/HR <u>Mass Modes:</u> MG/HR <u>Continuous Mode:</u> ml/HR <u>Volume/Time Mode:</u> dose volume, delivery time
Flow Rate	0.01 to 378.0 ml/hr dependent on syringe size selected (See Appendix I)
Bolus Rate	In Body Weight, Mass and Continuous Modes.
Power	AC Adapter; DC-Internal rechargeable batteries
Recharge Time	No longer than 16 hours with the pump turned off.
Battery Capacity	At 25 degrees C, a 16 hour charge will operate the pump for approximately 10 hours at 5.0 ml/hr with a 60 ml syringe.
Alarms/Alerts	<ul style="list-style-type: none"> • Near Empty • Empty • Dose Vol. Delivered • Bolus Delivery • Occlusion • System Malfunction • Low Battery • Depleted Battery • Syringe Pops Out • Invalid Size • Invalid Number • Check Clutch • Alarm Temporary Delay: 2 or 60 minutes • Alarm Audio Volume: Soft or Loud
Status Alerts	<ul style="list-style-type: none"> • Stop/Program • Deliver • Battery In Use • Battery Charging • Battery Depleted • Priming • Standby Mode • Back Light
Total Delivered	0000.0000 to 9999.9999 MG and 0000.0000 to 9999.9999 ml

GENERAL SPECIFICATIONS continued...

Syringe Selection

Version 1.2 — Five Options (4 Manufacturers):

Becton-Dickinson (B-D)	1, 3, 5, 10, 20, 30, 60 ml
Monoject (Mono)	1, 3, 6, 12, 20, 35, 60 ml
Terumo (Teru)	1, 3, 5, 10, 20, 30, 60 ml
Becton-Dickinson Glass (BD-G)	1, 3, 5, 10 ml
Abbott (Abot)	50 ml (Abboject)

Version 1.2A — also includes 3 additional syringe manufacturers:

Braun (BBM)	2, 5, 10, 20, 30, 60 ml
Fresenius (FRES)	10, 50 ml
Perfusor (PERF)	50 ml

**The following are trademarks: B-D (by Becton Dickinson and Company), Monoject (by Sherwood Medical), Abboject (by Abbott Laboratories) and Perfusor (by B.Braun).*

SECTION III

GENERAL DESCRIPTION/DIAGRAM

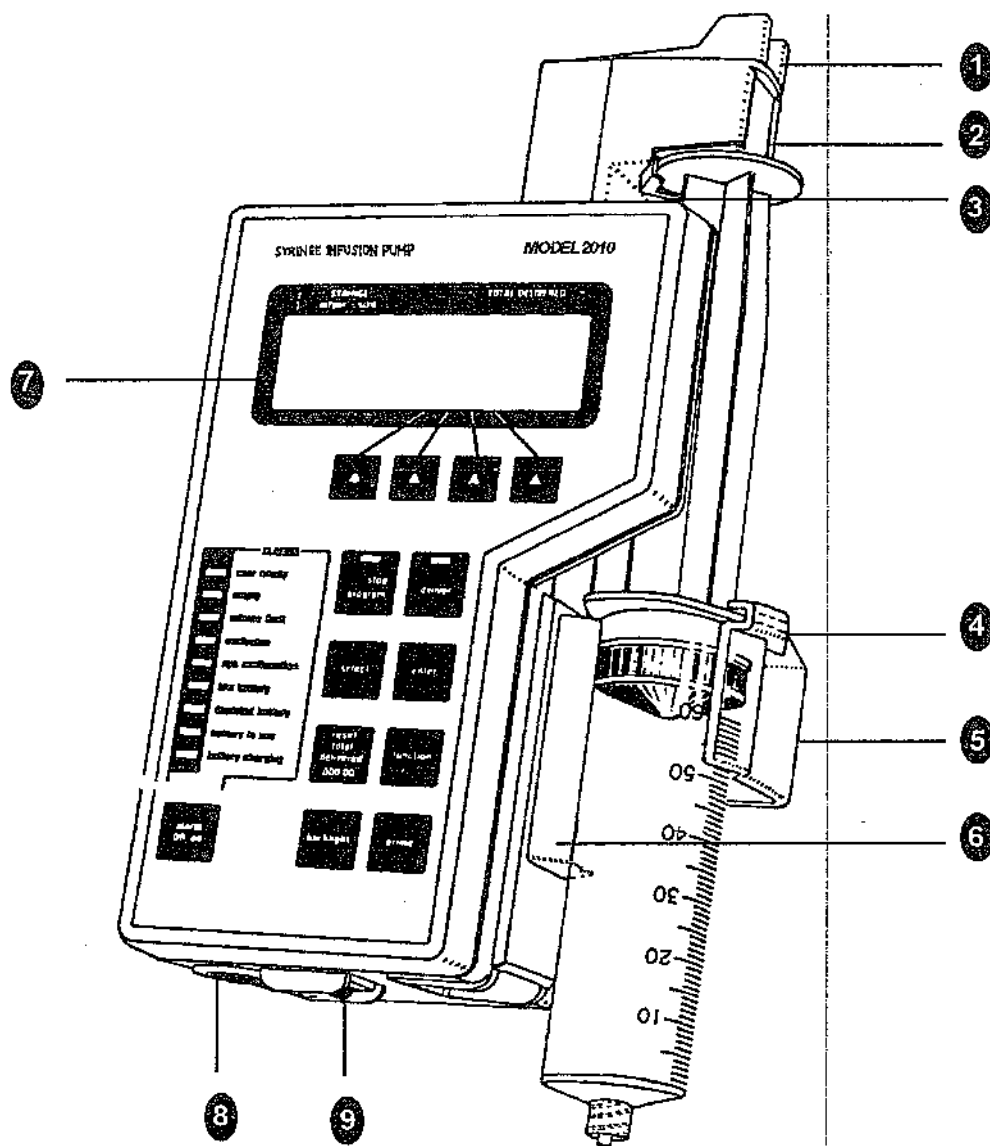

1. CLUTCH LEVER
2. SYRINGE DRIVER
3. SYRINGE PLUNGER RETAINER
4. SYRINGE CLAMP GROOVE (RETAINER)
5. SYRINGE CLAMP (CLEAR)
6. SYRINGE SADDLE
7. LCD (LIQUID CRYSTAL DISPLAY)
8. CHARGING RECEPTACLE
9. ON/OFF SWITCH

SECTION IV

OPERATING INSTRUCTIONS

STEP 1: SYRINGE LOADING

STEP 1A:

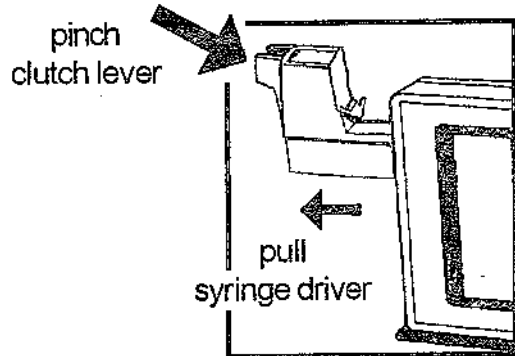

Pinch and hold together the **CLUTCH LEVER** (releases the clutch) and pull the **SYRINGE DRIVER** outward until it reaches the end of its track.

STEP 1B:

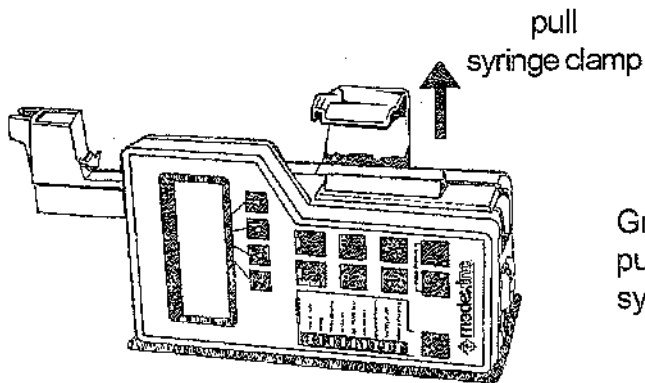

Grasp the clear **SYRINGE CLAMP**, pull upward allowing room for the syringe in the **SYRINGE SADDLE**.

STEP 1C:

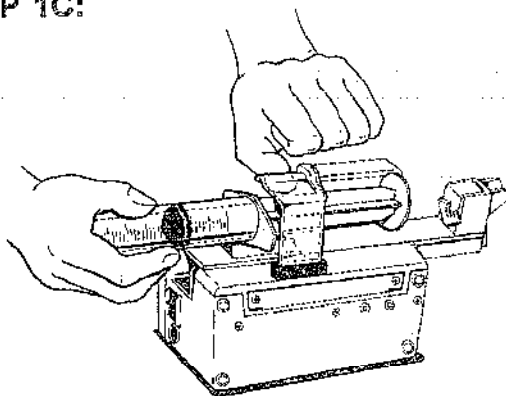

Insert the syringe, plunger end first.

OPERATING INSTRUCTIONS *continued...*

STEP 1C continued: **NOTE:** To be certain that the syringe is properly placed in the pump, make sure the graduations/ numbers on the syringe face up.

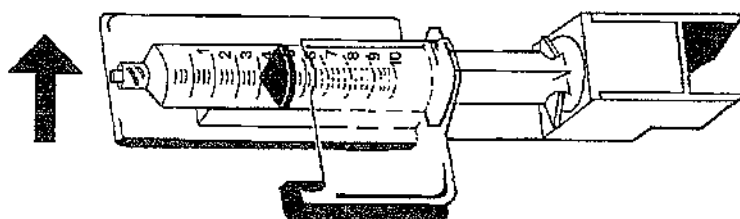

STEP 1D:

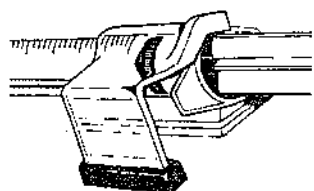

The clear syringe clamp must secure the syringe tabs within the syringe clamp groove. Syringe tabs can be rotated slightly.

Finger tabs should be parallel in relation to the clamp as shown:

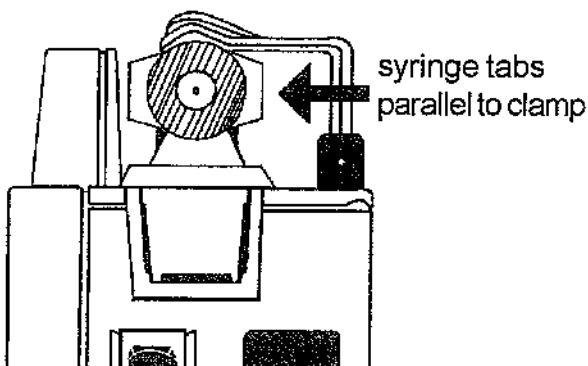
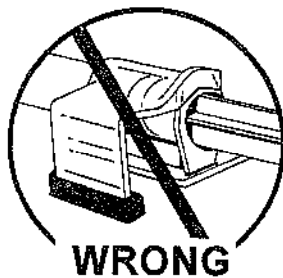

If not properly engaged, the pump may alarm after it has been in the deliver mode for a period of time.



CAUTION:

For all size syringes, be sure the finger tabs of the syringe engage the syringe clamp groove (retainer) and the syringe saddle.

OPERATING INSTRUCTIONS *continued...*

STEP 1E:

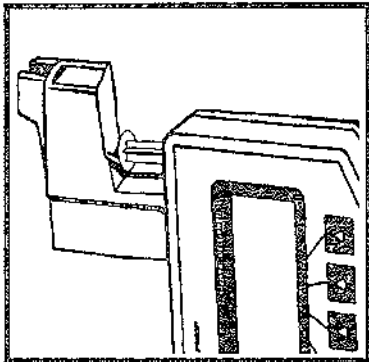

Pinch together the CLUTCH LEVER and move the SYRINGE DRIVER forward until the SYRINGE DRIVER contacts the plunger end of the DISPOSABLE SYRINGE.



IMPORTANT:

Make sure the CLUTCH LEVER snaps into its fully extended operating position.

STEP 1F:

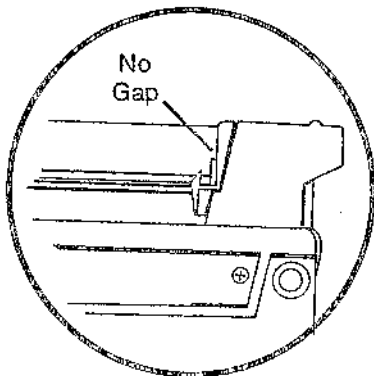

Insert the end of the SYRINGE PLUNGER into the SYRINGE PLUNGER RETAINER thus holding it in place. The SYRINGE PLUNGER may need to be lifted to load.



WARNING:

Failure to secure the syringe plunger to the plunger retainer may result in siphoning, causing overdelivery.

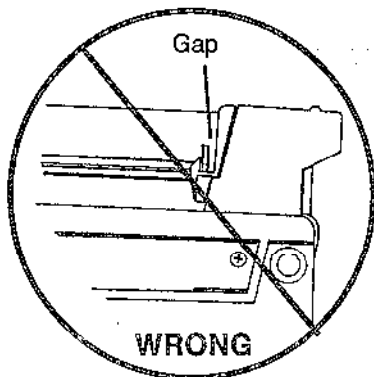

CAUTION:

The plunger must be in contact with the driver to begin immediate delivery. A gap could lead to a delay in delivery. Use the prime function to eliminate any gap.

OPERATING INSTRUCTIONS *continued...*

STEP 1G: REMOVING THE SYRINGE:

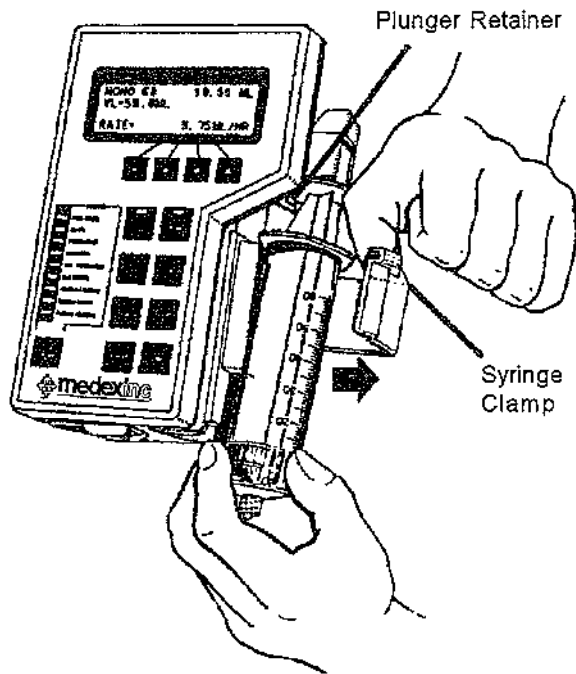

To remove syringe from pump: Lift up the clear syringe clamp and remove the empty syringe as shown.



IMPORTANT:

Be sure to lift the syringe plunger out of the plunger retainer (groove) before pulling the syringe out.

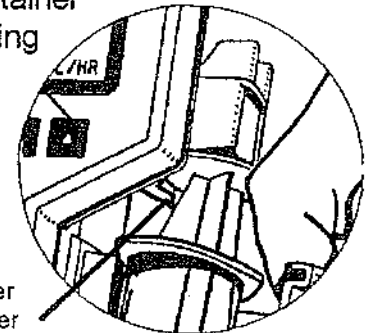

WARNING:

Failure to follow proper syringe removal procedures could cause damage to your pump, which may result in inaccurate drug delivery.

STEP 1H: **OPTIONAL** Loading Abbott Pre-Filled Syringes

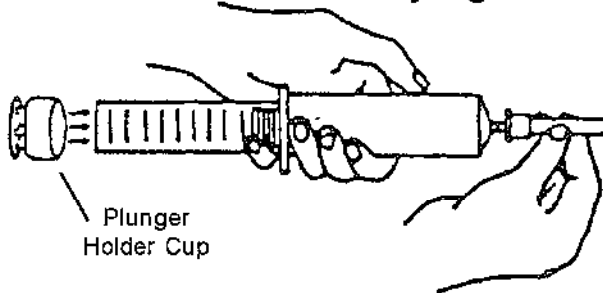

- Securely attach the plunger holder cup provided by Abbott to the end of the syringe plunger. (Glue or tape must be utilized to securely attach the plunger holder cup).
- Place the end of the cup into the plunger retainer as described in STEPS 1E and 1F.



WARNING:

Proper syringe loading and plunger holder cup placement is essential for proper delivery and actuation of the empty and near empty alarms. Improper use or the lack of use of the plunger holder cup may result in inaccuracy with ramifications that are drug dependent. Failure to secure the plunger holder cup to the syringe may result in siphoning, causing over-delivery.

OPERATING INSTRUCTIONS continued...

STEP 2: TURNING THE PUMP "ON"; REVIEWING THE CUSTOM PROGRAMMED FEATURES AND PUMP SELF TEST.

STEP 2A: The main power switch is located on the end of the pump. Switch it to the "ON" position (i.e., 0=Off, 1=On).

NOTE: Make sure the power cord is plugged into an electrical outlet (unless battery power is required).

When "ON," the LCD (Liquid Crystal Display) displays the following information:

Line 1 - Software version and a three digit number that defines the custom program options (See Appendix IV).

Line 2 - A **Bol** indicates a bolus feature was custom programmed. The **BATTERY VOLTAGE** (e.g., **BAT. V = 7.7**) appears as a two digit number.

NOTE: A blank LCD for **Bol** indicates this feature has not been custom programmed.

Line 3 - Alarms that were custom programmed appear. The first choice is either **LOUD** or **SOFT**, the second is the **TEMPORARY ALARM DELAY TIME** which is either **2 MIN** or **1 HR**, and the third is **ALARM OPTIONS** which is either **ALL** or **SOME**.

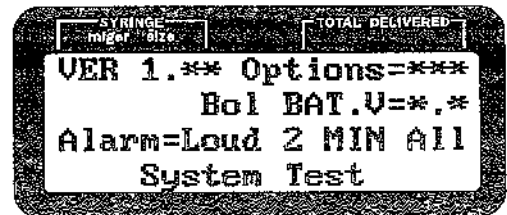

VER 1.** Options=***

Bol BAT.V=**

BAT.V=**

Alarm=Loud 2 MIN All

OPERATING INSTRUCTIONS continued...

System Test

The audio alarm sounds.

Line 4: The LCD states "SYSTEM TEST" then it states "LED/ALARM TEST" and all LEDs (*Light Emitting Diodes*) except the BATTERY CHARGING and SYSTEM MALFUNCTION briefly light.

NOTE: *The Battery In Use, STOP/PROGRAM, and DELIVER LEDs blink.*

LED/ALARM TEST

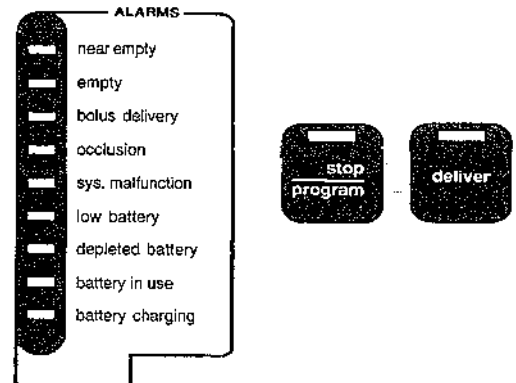

The pump performs a System Malfunction Test. The System Malfunction LED lights and the audio alarm sounds.

SYS. MAL. TEST

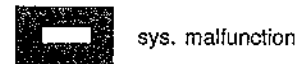

NOTE: The self test takes approximately seven (7) seconds.

OPERATING INSTRUCTIONS *continued...*

STEP 3: PROGRAMMING THE 2010 - INTRODUCTION

The program key "LED" blinks, and a slow intermittent beep (#1) sounds to indicate the Program Mode. (The alarm temporarily silences by pressing the ALARM OFF/ON Key once.) Program or function changes occur only in the Stop/Program Mode.

A single audio peck indicates a valid key press. (Occurs even when the audio is turned off.)

STEP 3A: ACCESSING THE DESIRED INFUSION MODE (only if more than one mode was custom programmed).

The Medfusion 2010 Syringe Pump employs sequential programming. The operator knows what selections can be made or programmed because they flash.

NOTE: The infusion modes appear in the following order, provided they were all custom programmed: BODY WEIGHT, MG/HR, ML/HR, VOLUME/TIME. These parameters do not appear if not custom programmed.

"PRESET MODE IS" on the third line of the LCD indicates only one mode was custom programmed. Refer to Section V, User Modes.

BODY WEIGHT MODE

STEP 3B:

NOTE: Bol (e.g., BOLUS) appears on the LCD only if custom programmed.

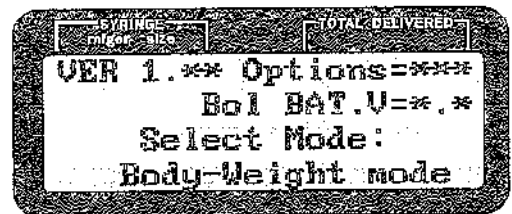

Press ENTER to use this mode. The pump automatically advances to the BODY WEIGHT program.



OR

Press SELECT to access other custom programmed infusion modes. The next choice appears sequentially (e.g., MG/HR, ML/HR, VOLUME/TIME).



OPERATING INSTRUCTIONS continued...

STEP 3C: MG PER HOUR (MG/HR)

Press ENTER to use this mode. The pump automatically advances to the MG/HR program.

OR

Press SELECT to access other custom programmed infusion modes. The next choice appears sequentially (e.g., ML/HR, VOLUME/TIME, BODY WEIGHT).

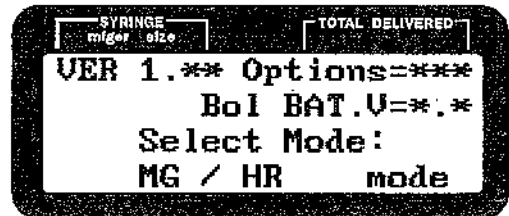

STEP 3D: ML PER HOUR (ML/HR)

Press ENTER to use this mode. The pump automatically advances to the ML/HR program.

OR

If another preprogrammed infusion mode is desired, press SELECT and the next choice appears (e.g., VOLUME/TIME, BODY WEIGHT, MG/HR).

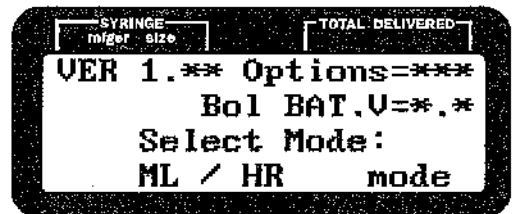

STEP 3E: VOLUME/TIME

Press ENTER to use this mode. The pump automatically advances to the VOLUME/TIME program.

NOTE: *If an Infusion Mode was not entered, the process is repeated.*

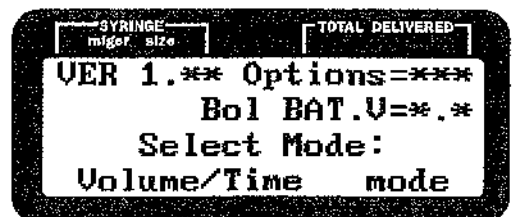

0
1
2
3
4
5
6
7
8
9
10
11
12
13
14
15
16
17
18
19
20
21
22
23
24
25
26
27
28
29
30
31
32
33
34
35
36
37
38
39
40
41
42
43
44
45
46
47
48
49
50
51
52
53
54
55
56
57
58
59
60
61
62
63
64
65
66
67
68
69
70
71
72
73
74
75
76
77
78
79
80
81
82
83
84
85
86
87
88
89
90
91
92
93
94
95
96
97
98
99

SECTION V

USER MODES

Go to the appropriate section for the mode you wish to program.

Body Weight	Pages 14-22
MG/HR	Pages 23-29
ML/HR	Pages 30-35
Volume/Time	Pages 36-40

Introduction

Body Weight Mode

The Body Weight Mode allows programming for delivery in mcg/kg/min, mcg/kg/HR, MG/kg/min and MG/kg/HR. Locking in a single rate mode simplifies programming by limiting selection to one of the four available choices. Entry of the concentration, weight and rate are required. Additionally, a bolus amount may be custom programmed for delivery of a specific bolus of fluid or drug from any size syringe. It delivers at the fastest rate possible for the syringe in use. The Body Weight Mode conveniently delivers in a variety of Rate Modes for meticulous infusion of drugs or fluids.

NOTE: The pump remembers the last programmed settings (except Total Delivered) even after being turned OFF. Therefore, if the operator elects to use the same infusion mode, the last values will appear. They may be changed or confirmed. All settings will be erased and set to zero if the infusion mode is changed.

STEP 1: BODY WEIGHT

When the pump is turned ON, lines 3 and 4 of the LCD display appear as follows:

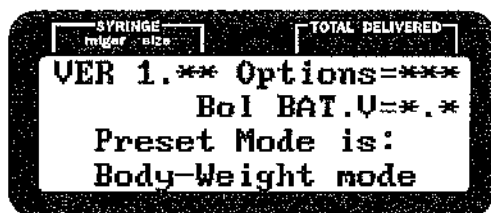

If "PRESET MODE IS" appears, no other modes were custom programmed.

OR

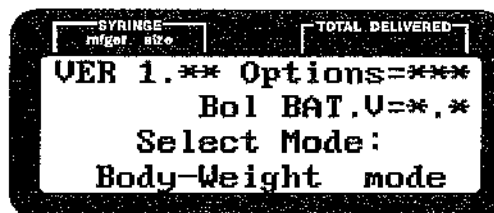

If "SELECT MODE" appears, other infusion modes can be selected by using the SELECT key (see Section IV, Step 3). To select Body Weight, press ENTER.



To display other modes



To enter mode displayed

USER MODES continued...

Body Weight

STEP 2: RATE MODE

The last programmed RATE MODE will flash. To confirm, press ENTER.

Press SELECT to change RATE MODE choices.

Press ENTER to confirm choice.

NOTE: In this example mcg/kg/min was entered.

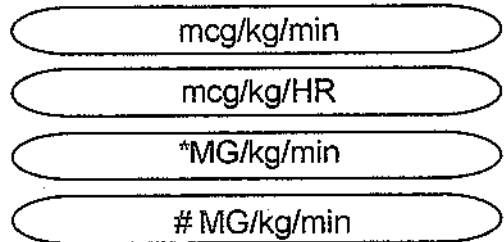
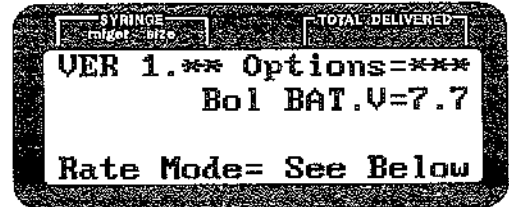

STEP 3: BOLUS AMOUNT (CUSTOM PROGRAMMABLE)

NOTE: If a BOLUS AMOUNT is custom programmed, the LCD will display the last programmed parameter (e.g., Bolus Amount = Yes to No). If a BOLUS AMOUNT is not custom programmed, the pump will automatically skip to Step 4.

If NO is entered, the LCD will automatically skip to Step 4.

If YES is entered, a BOLUS delivery is possible.

NOTE: A BOLUS will be administered at the fastest rate possible for the syringe size in use.

STEP 4: PROGRAMMING SYRINGE MANUFACTURER (CUSTOM PROGRAMMABLE)

NOTE: If a syringe manufacturer is custom programmed, the pump automatically advances to **LOAD SYRINGE**. Entry into the custom program mode allows a syringe manufacturer change.

Press the **SELECT** key to make the choices appear on the LCD. Repeated presses of the **SELECT** key display the available choices. For example, **B-D** refers to Becton-Dickinson, **Mono** refers to Monoject, **Teru** refers to Terumo and **BD-G** refers to B-D glass, and **ABOT** refers to Abbott prefilled syringe, etc.

Press **ENTER** to confirm your selection.

NOTE: The **SYRINGE MANUFACTURER** appears on the LCD and the pump automatically advances to the next programmable item.

NOTE: Turn the main power off and start over to correct an inadvertent mis-entry of the Syringe Manufacturer. A correction is possible only if **SELECT MANUFACTURER** appears on the LCD.

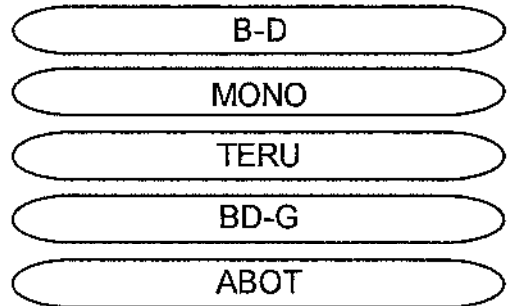
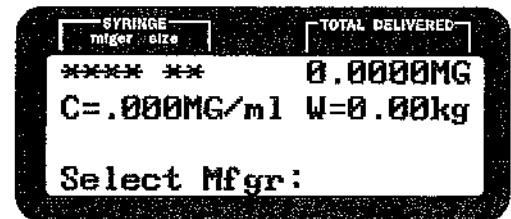

In this example **MONO** was entered.



WARNING: Verify that the syringe manufacturer on the LCD is the same as the syringe in use. Failure to use the listed manufacturer could result in inaccurate delivery. The pump cannot automatically identify syringe manufacturer.

STEP 5: PROGRAMMING SYRINGE SIZE

The fourth line of the LCD alternately flashes "LOAD SYRINGE — PRESS enter."

If the syringe is not already loaded onto the pump, load the syringe as instructed (see Section IV, Operating Instructions).

Once the syringe is properly loaded, press the ENTER key. The pump will automatically enter the correct syringe size and advance to the next programmable item, unless use of the B-D luer lock syringe was selected in custom programming in which case the operator must select syringe size (i.e., 1cc or 3cc). (See Appendix V)

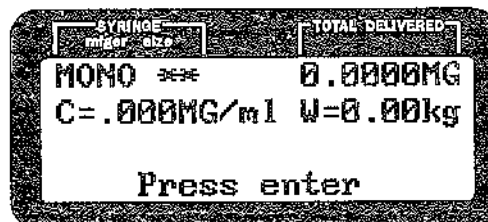
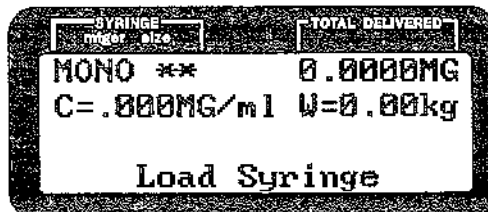

WARNING: Always confirm that the syringe size stated on the LCD agrees with the size of the syringe loaded on the pump. Failure to select the correct syringe size will result in inaccurate delivery.



WARNING: If the B-D luer lock option was selected in custom programming, the operator must select the appropriate syringe size (i.e., 1cc or 3cc). The pump cannot distinguish between these syringe sizes.

STEP 6: PROGRAMMING CONCENTRATION (mg per ml)

STEP 6A: CHANGING DECIMAL POINT LOCATION

If the decimal point is located appropriately skip to Step 6B. If the decimal point needs to be shifted, follow the procedure below.

Press the PROTOCOL/DECIMAL key to change the location of the decimal point.

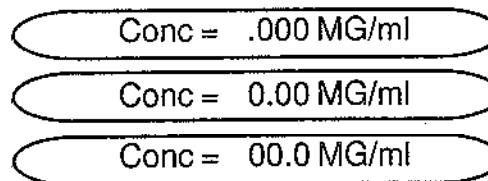
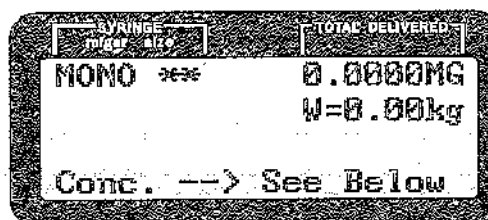

STEP 6B: PROGRAMMING CONCENTRATION VALUE

To program a CONCENTRATION (Conc.), press the RATE SELECTION key(s) located beneath the flashing numerals. The SELECT key does not program concentration.

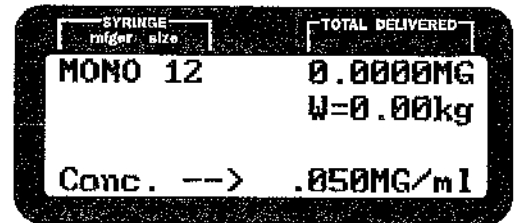

Press ENTER to enter the desired concentration.

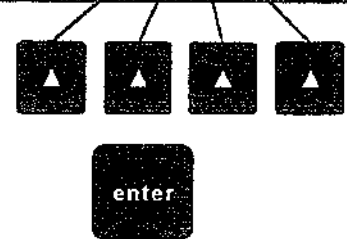

STEP 7: PROGRAMMING WEIGHT (KILOGRAMS)

STEP 7A: CHANGING THE DECIMAL POINT LOCATION

If the decimal point is located appropriately skip to STEP 7B. If the decimal point needs to be shifted follow the procedure below.

Press the PROTOCOL/DECIMAL key to change the location of the decimal point.

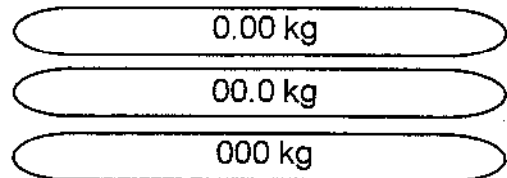
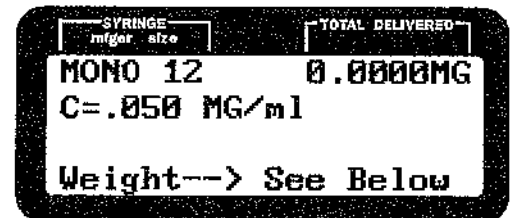

STEP 7B: PROGRAMMING WEIGHT VALUE

To program a weight, press the RATE selection key(s) located beneath the flashing numerals. The SELECT key does not program weight.

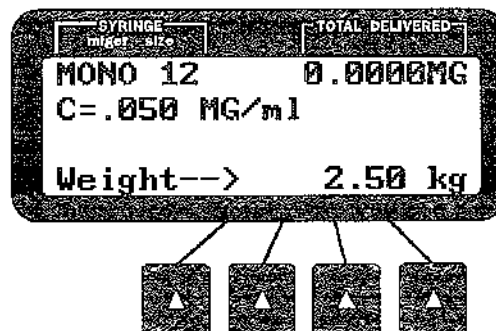

Press ENTER key to enter the desired weight.



STEP 8: PROGRAMMING A BOLUS AMOUNT (CUSTOM PROGRAMMABLE)

If BOLUS amount does not appear on the LCD, it was not custom programmed, the pump automatically skips to Step 9.

The BOLUS AMOUNT allows delivery of a specific preprogrammed bolus of fluid or drug from any size syringe. The decimal point position of the BOLUS AMOUNT is fixed and determined by the RATE MODE selected (e.g., in mcg/kg/min and mcg/kg/HR the bolus decimal is fixed at 0000 mcg/kg; in the MG/kg/min and MG/kg/HR, the bolus decimal is fixed at 00.00 MG/kg).

See section, "BOLUS"
for detailed information on programming,
delivering and reprogramming bolus doses.

USER MODES continued...

Body Weight

STEP 9: PROGRAMMING RATE

STEP 9A: CHANGING DECIMAL POINT

If the decimal point is located appropriately, skip to Step 9B. If the decimal point needs to be changed, follow the procedure below.

Press the PROTOCOL/DECIMAL key to change the location of the decimal point.

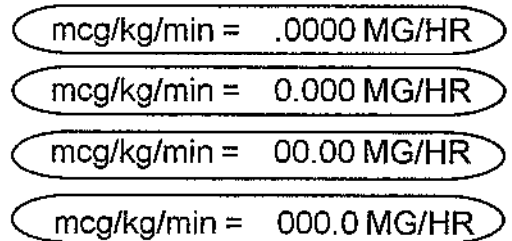
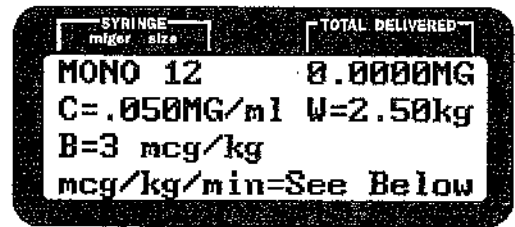

STEP 9B: PROGRAMMING RATE

To program a RATE, press the RATE selection key(s) located beneath the flashing numerals.

NOTE: *Continuously pressing the RATE selection key automatically advances the number.*

Press ENTER to enter the desired rate.

No information on the LCD flashes. When the display is solid (not flashing), the operator should PRIME to remove any mechanical slack before commencing DELIVERY.

NOTE: *INVALID NUMBER displays on the LCD when an invalid rate entry occurs followed by the highest possible rate programmable for the syringe selected.*

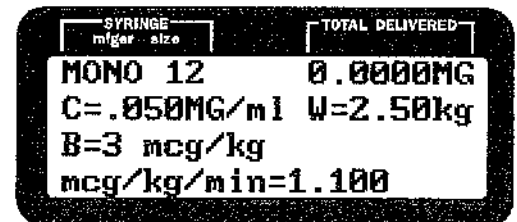
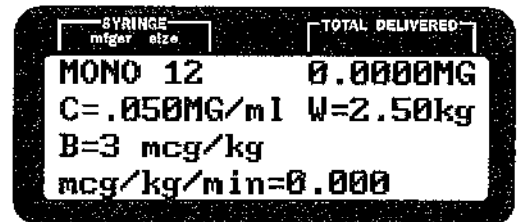

USER MODES continued...

Body Weight

STEP 10: PRIMING

For important detailed information on priming please see section "PRIME".

STEP 11: DELIVERY

STEP 11A: INITIATING DELIVERY

Press the DELIVER key to begin the infusion. The LCD will not flash and the green LED DELIVER light begins to blink.

In the DELIVERY MODE, all keys are inactive for programming except the ALARM ON/OFF key, the BOLUS DELIVERY key(s) provided a BOLUS was programmed, and the RATE SELECTION key(s).

STEP 11B: DELIVERY-VIEW ML/HR AND SIMPLIFY SCREEN

VIEW

While delivering the operator can temporarily display the TOTAL DELIVERED in ml and the RATE in ml per hour by pressing and releasing the ENTER key.

NOTE: The ml conversion can also be viewed in STOP/PROGRAM by pressing the ENTER key.

SIMPLIFY

Press the SELECT key while delivering to simplify the screen. Another press of SELECT will make the full screen reappear.

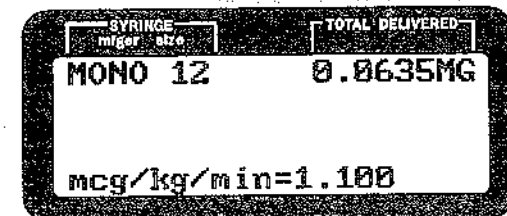
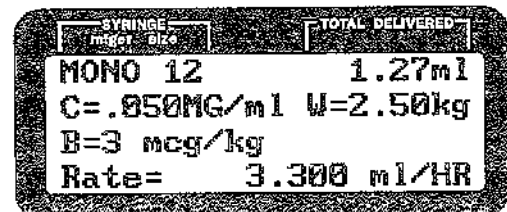
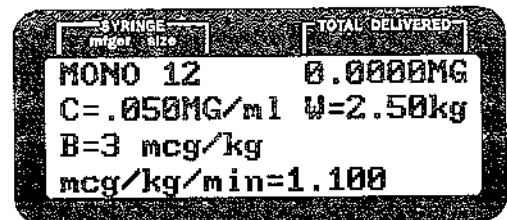

STEP 11C: CHANGING THE RATE

The operator can change the infusion RATE by two methods: See Section "RATE CHANGES" for detailed information on same.

STEP 12: BOLUS PROGRAMMING

See Section "BOLUS" for detailed information on programming, delivering and reprogramming bolus doses.

STEP 13: STOP DELIVERY

Press the STOP/PROGRAM key to stop the infusion. The STOP/PROGRAM LED blinks and a slow intermittent #1 audio alarm sounds.



NOTE: Alarms (e.g., occlusion, depleted battery, syringe pops out) interrupt delivery. Correct the alarm and press the DELIVER key to resume.



STEP 14: STOPPING A BOLUS

A BOLUS may be stopped at any time by pressing the STOP/PROGRAM key. The BOLUS AMOUNT given will be briefly displayed before the LCD returns to the previously programmed rate.



Press DELIVER key to resume delivery.



STEP 15: PROGRAMMING STANDBY TIME

The STANDBY MODE allows temporary suspension of an infusion while retaining all pertinent data (e.g., rate, total delivered, syringe size, syringe manufacturer, etc.)

See Section "STANDBY MODE" for detailed information on programming and cancelling standby time.



Introduction Mass Mode - MG/HR

The Mass Mode allows programming of a concentration value in MG/HR. Additionally, a bolus amount may be custom programmed for delivery of a specific bolus of fluid or drug from any size syringe. It delivers at the fastest rate possible for the syringe in use. The Mass Mode conveniently delivers in MG/HR for meticulous infusion of drugs or fluids.

STEP 1: MG/HR MODE

When the pump is turned ON, lines 3 and 4 of the LCD display appear as follows:

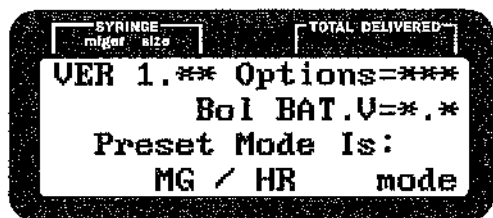

OR

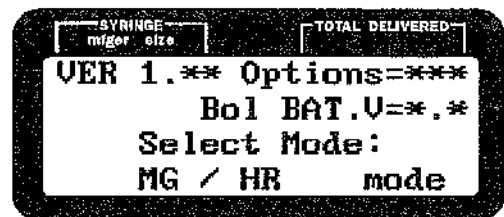

If "PRESET MODE IS" appears, no other infusion modes were custom programmed.

If "SELECT MODE" appears, other infusion modes can be selected by using the SELECT key. (See Section IV). To select MG/HR, press ENTER.

STEP 2: BOLUS AMOUNT (CUSTOM PROGRAMMABLE)

NOTE: If a BOLUS AMOUNT is custom programmed, the LCD will display the last programmed parameter (e.g., Bolus Amount = Yes or No). If a BOLUS AMOUNT is not custom programmed the pump will automatically skip to Step 3.

If NO is entered the LCD will automatically skip to Step 3.

If YES is entered a BOLUS delivery is possible.

NOTE: A BOLUS will be administered at the fastest rate possible for the syringe size in use.

STEP 3: PROGRAMMING SYRINGE MANUFACTURER (CUSTOM PROGRAMMABLE)

NOTE: If a syringe manufacturer is custom programmed, the pump automatically advances to **LOAD SYRINGE**. Entry into the custom program mode allows a syringe manufacturer change.

Press the **SELECT** key to make the choices appear on the LCD. Repeated presses of the **SELECT** key display the available choices. For example, **B-D** refers to Becton-Dickinson, **Mono** refers to Monoject, **Teru** refers to Terumo and **BD-G** refers to B-D glass, and **ABOT** refers to Abbott prefilled syringe, etc.

Press **ENTER** to confirm your selection.

NOTE: The **SYRINGE MANUFACTURER** appears on the LCD and the pump automatically advances to the next programmable item.

NOTE: Turn the main power off and start over to correct an inadvertent mis-entry of the Syringe Manufacturer. A correction is possible only if **SELECT MANUFACTURER** appears on the LCD.

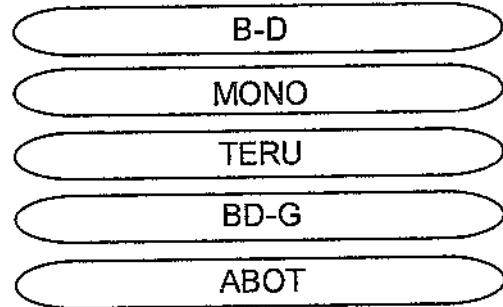
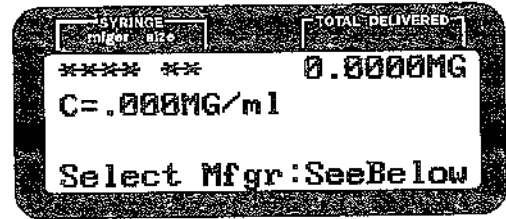

In this example **MONO** was entered.



WARNING:

Verify that the syringe manufacturer on the LCD is the same as the syringe in use. Failure to use the listed manufacturer could result in inaccurate delivery. The pump cannot automatically identify syringe manufacturer.

STEP 4: PROGRAMMING SYRINGE SIZE

The fourth line of the LCD alternately flashes "LOAD SYRINGE — PRESS enter."

If the syringe is not already loaded onto the pump, load the syringe as instructed (see Section IV, Operating Instructions).

Once the syringe is properly loaded, press the ENTER key. The pump will automatically enter the correct syringe size and advance to the next programmable item, unless use of the B-D luer lock syringe was selected in custom programming in which case the operator must select syringe size (i.e., 1cc or 3cc). (See Appendix V)

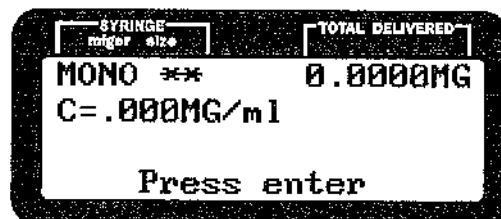
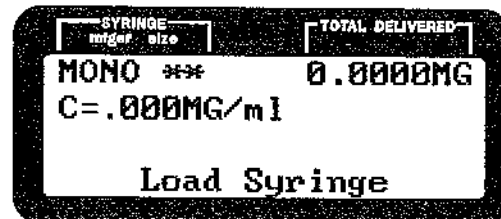

WARNING: Always confirm that the syringe size stated on the LCD agrees with the size of the syringe loaded on the pump. Failure to select the correct syringe size will result in inaccurate delivery.



WARNING: If the B-D luer lock option was selected in custom programming, the operator must select the appropriate syringe size (i.e., 1cc or 3cc). The pump cannot distinguish between these syringe sizes.

STEP 5: PROGRAMMING CONCENTRATION (mg per ml)

STEP 5A: CHANGING DECIMAL POINT LOCATION

If the decimal point is located appropriately skip to Step 5B. If the decimal point needs to be shifted, follow the procedure below.

Press the PROTOCOL/DECIMAL key to change the location of the decimal point.

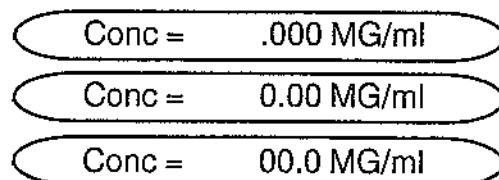
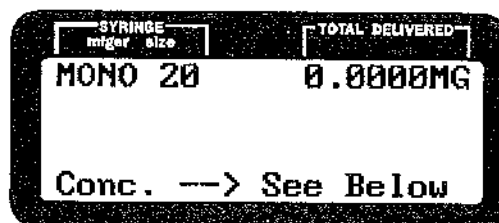

STEP 5B: PROGRAMMING CONCENTRATION VALUE

To program a CONC, press the RATE selection key(s) located beneath the flashing numerals. The SELECT key does not program concentration.

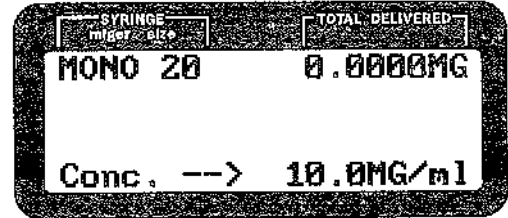

Press ENTER key to enter the desired concentration.



STEP 6: PROGRAMMING A BOLUS AMOUNT (CUSTOM PROGRAMMABLE)

If BOLUS AMOUNT does not appear on the LCD, it was not custom programmed, the pump automatically skips to Step 7..

The BOLUS AMOUNT allows delivery of a specific preprogrammed bolus of fluid or drug from any size syringe. The decimal point position of the BOLUS AMOUNT is fixed and determined by the RATE MODE selected (e.g., in mcg/kg/min and mcg/kg/HR the bolus decimal is fixed at 0000 mcg/kg; in the MG/kg/min and MG/kg/HR, the bolus decimal is fixed at 00.00 MG/kg).

See section, "BOLUS"
for detailed information on programming,
delivering and reprogramming bolus doses.

USER MODES continued...

Mass Mode

STEP 7: PROGRAMMING RATE (MG per hour)

STEP 7A: CHANGING THE DECIMAL POINT LOCATION

If the decimal point is located appropriately, skip to Step 7B. If the decimal point needs to be changed, follow the procedure below.

Press the PROTOCOL/DECIMAL key to change the location of the decimal point.

NOTE: If the decimal point of the RATE is changed a new BOLUS amount will be requested after the new RATE is entered. The decimal point for both the RATE and BOLUS are automatically placed in the same location.

STEP 7B: PROGRAMMING RATE

To program a RATE, press the RATE selection key(s) located beneath the flashing numerals.

NOTE: Continuously pressing the RATE selection key automatically advances the number.

Press ENTER to enter the desired rate.

No information on the LCD flashes. When the display is solid (not flashing), the operator should PRIME to remove any mechanical slack before commencing DELIVERY.

NOTE: INVALID NUMBER displays on the LCD when an invalid rate entry occurs followed by the highest possible rate programmable for the syringe selected.

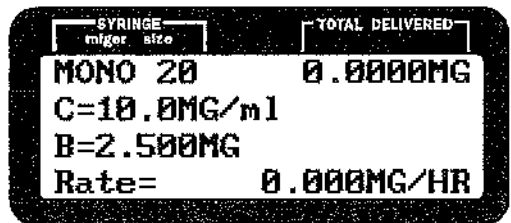
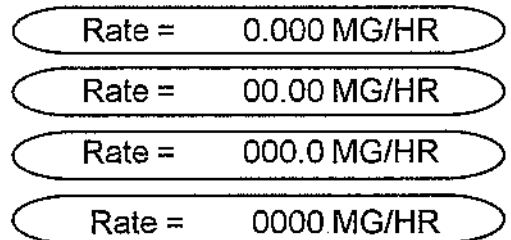
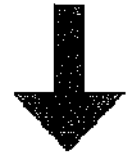
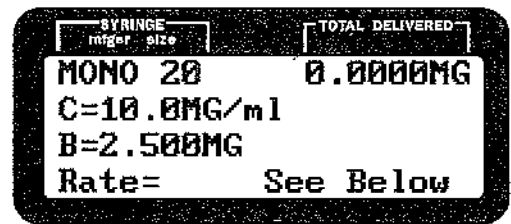

OR

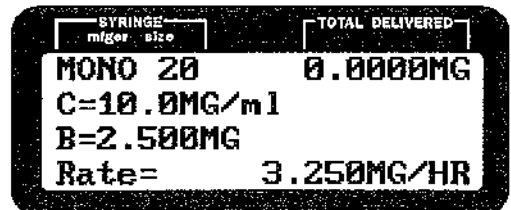
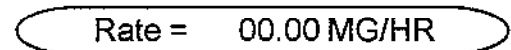

OR

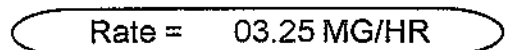

STEP 8: PRIMING

For important detailed information on priming please see section "PRIME".

STEP 9: DELIVERY

STEP 9A: INITIATING DELIVERY

Press the DELIVER key to begin the infusion. The LCD will not flash and the green LED DELIVER light begins to blink.

In the DELIVERY MODE, all keys are inactive for programming except the ALARM ON/OFF key, the BOLUS DELIVERY key(s) provided a BOLUS was programmed, and the RATE SELECTION key(s).

STEP 9B: DELIVERY-VIEW ML/HR AND SIMPLIFY SCREEN

VIEW

While delivering the operator can temporarily display the TOTAL DELIVERED in ml and the RATE in ml per hour by pressing and releasing the ENTER key.

NOTE: The ml conversion can also be viewed in STOP/PROGRAM by pressing the ENTER key.

SIMPLIFY

Press the SELECT key while delivering to simplify the screen. Another press of SELECT will make the full screen reappear (not shown).

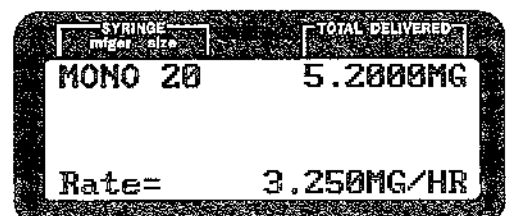
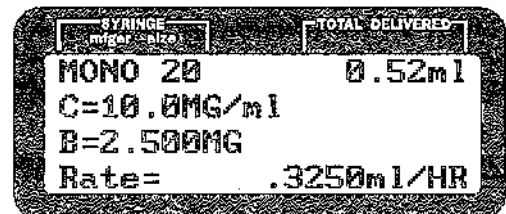
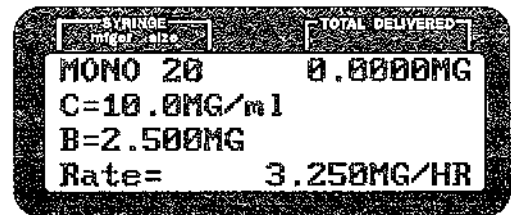

STEP 9C: CHANGING THE RATE

The operator can change the infusion RATE by two methods: See Section "RATE CHANGES" for detailed information on same.

STEP 10: BOLUS PROGRAMMING

See Section "BOLUS" for detailed information on programming, delivering and reprogramming bolus doses.

STEP 11: STOP DELIVERY

Press the STOP/PROGRAM key to stop the infusion. The STOP/PROGRAM LED blinks and a slow intermittent #1 audio alarm sounds.

NOTE: Alarms (e.g., occlusion, depleted battery, syringe pops out) interrupt delivery. Correct the alarm and press the DELIVER key to resume.



STEP 12: STOPPING A BOLUS

A BOLUS may be stopped at anytime by pressing the STOP/PROGRAM key. The BOLUS AMOUNT given will be briefly displayed before the LCD returns to the previously programmed rate.

Press DELIVER key to resume delivery.



STEP 13: PROGRAMMING STANDBY TIME

The STANDBY MODE allows temporary suspension of an infusion while retaining all pertinent data (e.g., rate, total delivered, syringe size, syringe manufacturer, etc.)

See Section "STANDBY MODE" for detailed information on programming and cancelling standby time.

11/11/2019 11:11:11 AM

Introduction Continuous Mode - ML/HR

The Continuous Mode allows programming of the rate in ml/HR. Additionally, a bolus amount may be custom programmed for delivery of a specific bolus of fluid or drug from any size syringe. It delivers at the fastest rate possible for the syringe in use. The Continuous Mode conveniently delivers in ml/HR for meticulous infusion of drugs or fluids.

STEP 1: ML/HR MODE

When the pump is turned ON, lines 3 and 4 of the LCD display appear as follows:

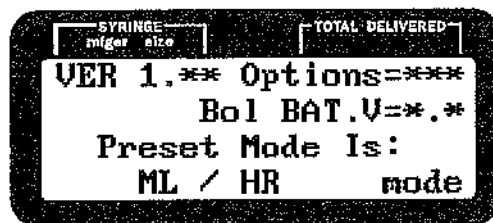

OR

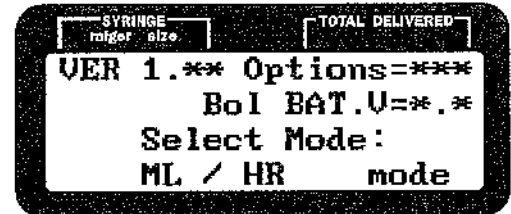

If "PRESET MODE IS" appears, no other infusion modes were custom programmed.

If "SELECT MODE" appears, other infusion modes can be selected by using the SELECT key. (See Section IV). To select ML/HR, press ENTER.

STEP 2: BOLUS AMOUNT (CUSTOM PROGRAMMABLE)

NOTE: If a BOLUS AMOUNT is custom programmed, the LCD will display the last programmed parameter (e.g., Bolus Amount = Yes or No). If a BOLUS AMOUNT is not custom programmed the pump will automatically skip to Step 3.

If NO is entered the LCD will automatically skip to Step 3.

If YES is entered a BOLUS delivery is possible.

NOTE: A BOLUS will be administered at the fastest rate possible for the syringe size in use.

STEP 3: PROGRAMMING SYRINGE MANUFACTURER (CUSTOM PROGRAMMABLE)

NOTE: If a syringe manufacturer is custom programmed, the pump automatically advances to **LOAD SYRINGE**. Entry into the custom program mode allows a syringe manufacturer change.

Press the **SELECT** key to make the choices appear on the LCD. Repeated presses of the **SELECT** key displays the available choices. For example, **B-D** refers to Becton-Dickinson, **Mono** refers to Monoject, **Teru** refers to Terumo and **BD-G** refers to B-D glass, and **ABOT** refers to Abbott prefilled syringe, etc.

Press **ENTER** to confirm your selection.

NOTE: The **SYRINGE MANUFACTURER** appears on the LCD and the pump automatically advances to the next programmable item.

NOTE: Turn the main power off and start over to correct an inadvertent mis-entry of the Syringe Manufacturer. A correction is possible only if **SELECT MANUFACTURER** appears on the LCD.

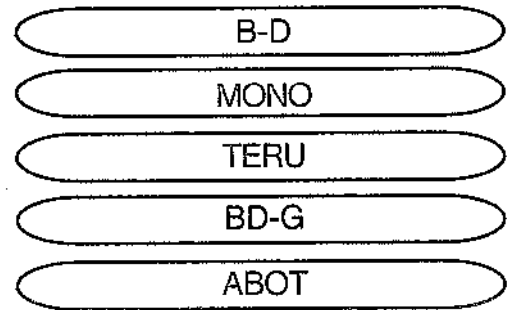
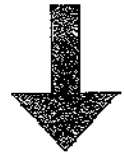
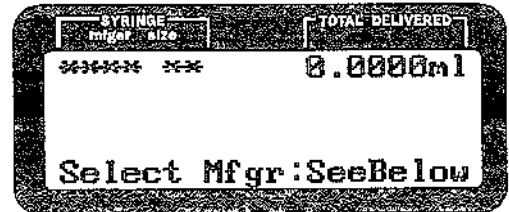

In this example **MONO** was entered.



WARNING:

Verify that the syringe manufacturer on the LCD is the same as the syringe in use. Failure to use the listed manufacturer could result in inaccurate delivery. The pump cannot automatically identify syringe manufacturer.

STEP 4: PROGRAMMING SYRINGE SIZE

The fourth line of the LCD alternately flashes "LOAD SYRINGE — PRESS enter."

If the syringe is not already loaded onto the pump, load the syringe as instructed (see Section IV, Operating Instructions).

Once the syringe is properly loaded, press the ENTER key. The pump will automatically enter the correct syringe size and advance to the next programmable item, unless use of the B-D luer lock syringe was selected in custom programming in which case the operator must select syringe size (i.e., 1cc or 3cc). (See Appendix V)



WARNING: Always confirm that the syringe size stated on the LCD agrees with the size of the syringe loaded on the pump. Failure to select the correct syringe size will result in inaccurate delivery.



WARNING: If the B-D luer lock option was selected in custom programming, the operator must select the appropriate syringe size (i.e., 1cc or 3cc). The pump cannot distinguish between these syringe sizes.

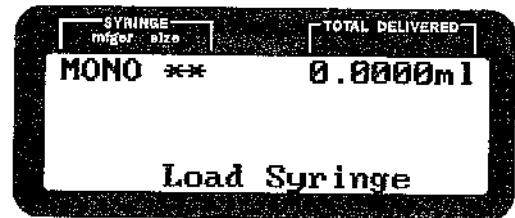

STEP 5: PROGRAMMING A BOLUS AMOUNT (CUSTOM PROGRAMMABLE)

If BOLUS AMOUNT does not appear on the LCD, it was not custom programmed, the pump automatically skips to Step 6.

The BOLUS AMOUNT allows delivery of a specific preprogrammed bolus of fluid or drug from any size syringe. The decimal point position of the BOLUS AMOUNT is determined by the decimal point location selected for the rate. It cannot be changed unless the rate decimal point is changed.

Program the BOLUS AMOUNT with the RATE SELECTION key(s). Continuously pressing the RATE SELECTION key(s) automatically advances the number.

Press ENTER to program the desired BOLUS AMOUNT. The LCD automatically advances.

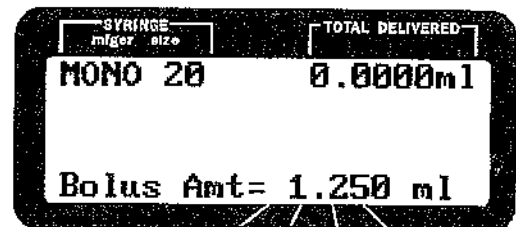

OR

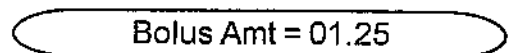

STEP 6: PROGRAMMING RATE (MG per hour)

STEP 6A: CHANGING THE DECIMAL POINT LOCATION

If the decimal point is located appropriately, skip to Step 6B. If the decimal point needs to be changed, follow the procedure below.

Press the PROTOCOL/DECIMAL key to change the location of the decimal point.

NOTE: If the decimal point of the RATE is changed a new BOLUS amount will be requested after the new RATE is entered. The decimal point for both the RATE and BOLUS are automatically placed in the same location.

STEP 6B: PROGRAMMING RATE

To program a RATE, press the RATE selection key(s) located beneath the flashing numerals.

NOTE: Continuously pressing the RATE selection key automatically advances the number.

Press ENTER to enter the desired rate.

No information on the LCD flashes. When the display is solid (not flashing), the operator should PRIME to remove any mechanical slack before commencing DELIVERY.

NOTE: INVALID NUMBER displays on the LCD when an invalid rate entry occurs followed by the highest possible rate programmable for the syringe selected.



CAUTION: The rate does not reset to 0 when the syringe size is changed.

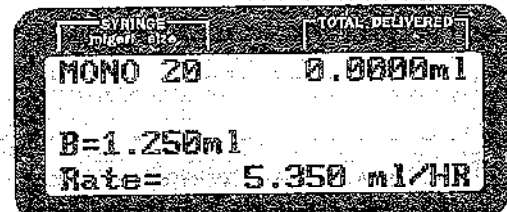
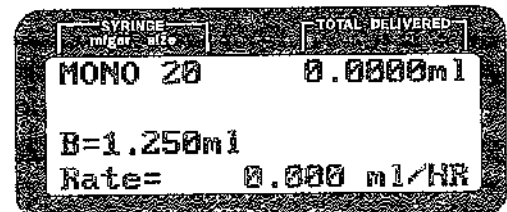
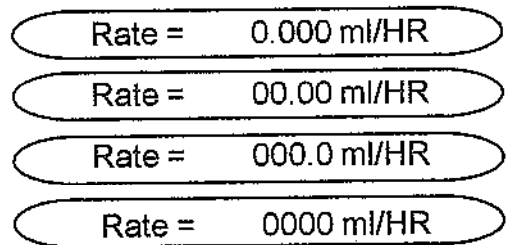
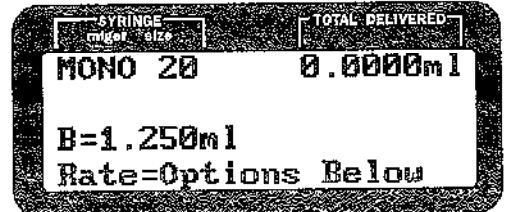

OR

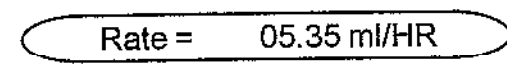

USER MODES continued...

Continuous Mode

NOTE: Decimal point placement for rate may necessitate reentry of the Bolus. When the Bolus is reentered, the decimal placement changes accordingly.

The final screen, after the Bolus reentry is as shown.

STEP 7: PRIMING

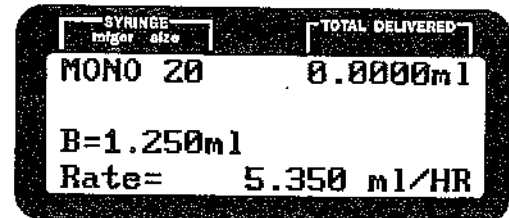

For important detailed information on priming please see section "PRIME".

STEP 8: DELIVERY

STEP 8A: INITIATING DELIVERY

Press the DELIVER key to begin the infusion. The LCD will not flash and the green LED DELIVER light begins to blink.

In the DELIVERY MODE, all keys are inactive for programming except the ALARM ON/OFF key, the BOLUS DELIVERY key(s) provided a BOLUS was programmed, and the RATE SELECTION key(s).

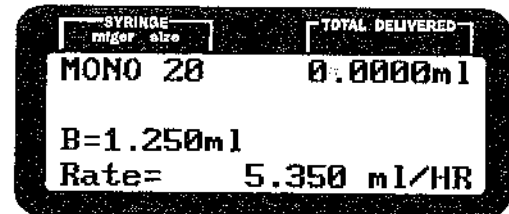

STEP 8B: CHANGING THE RATE

The operator can change the infusion RATE by two methods: See Section "RATE CHANGES" for detailed information on same.

STEP 9: BOLUS PROGRAMMING

See Section "BOLUS" for detailed information on programming, delivering and reprogramming bolus doses.

STEP 10: STOP DELIVERY

Press the STOP/PROGRAM key to stop the infusion. The STOP/PROGRAM LED blinks and a slow intermittent #1 audio alarm sounds.



NOTE: Alarms (e.g., occlusion, depleted battery, syringe pops out) interrupt delivery. Correct the alarm and press the DELIVER key to resume.



STEP 11: STOPPING A BOLUS

A BOLUS may be stopped at anytime by pressing the STOP/PROGRAM key. The BOLUS AMOUNT given will be briefly displayed before the LCD returns to the previously programmed rate.



Press DELIVER key to resume delivery.



STEP 12: PROGRAMMING STANDBY TIME

The STANDBY MODE allows temporary suspension of an infusion while retaining all pertinent data (e.g., rate, total delivered, syringe size, syringe manufacturer, etc.)

See Section "STANDBY MODE" for detailed information on programming and cancelling standby time.

Introduction Volume/Time Mode

The VOLUME OVER TIME mode requires entry of two infusion parameters—the desired DOSE VOLUME (DV) and the desired DELIVERY TIME (DT). This mode is most useful in delivery of a single dose. The rate in ml per hour calculates automatically. The DOSE VOLUME becomes the VOLUME LIMIT (VL). Use this mode when one needs to deliver a single dose over time.

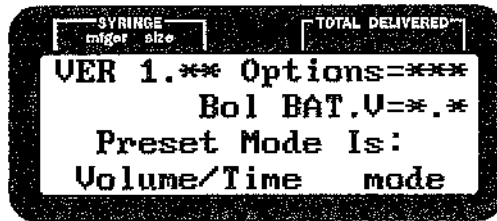

or

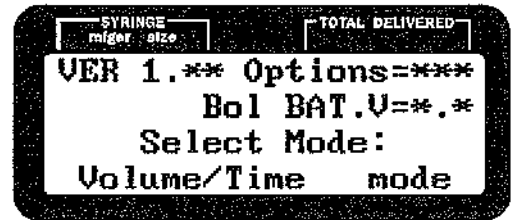

If "PRESET MODE IS" appears, no other infusion modes were custom programmed.

If "SELECT MODE" appears, other infusion modes can be selected by using the SELECT key. (See Section IV). To select ml/HR, press ENTER.

STEP 3: PROGRAMMING SYRINGE MANUFACTURER (CUSTOM PROGRAMMABLE)

NOTE: If a syringe manufacturer is custom programmed, the pump automatically advances to LOAD SYRINGE. Entry into the custom program mode allows a syringe manufacturer change.

Press the SELECT key to make the choices appear on the LCD. Repeated presses of the SELECT key display the available choices. For example, B-D refers to Becton-Dickinson, Mono refers to Monoject, Teru refers to Terumo and BD-G refers to B-D glass, and ABOT refers to Abbott prefilled syringe, etc.

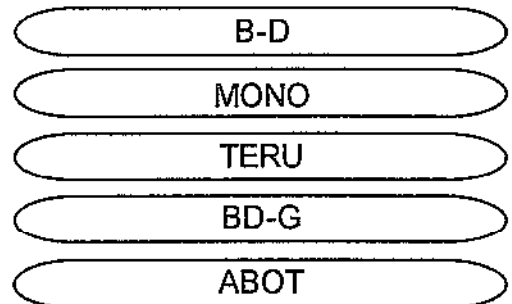
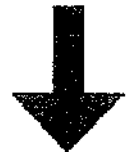
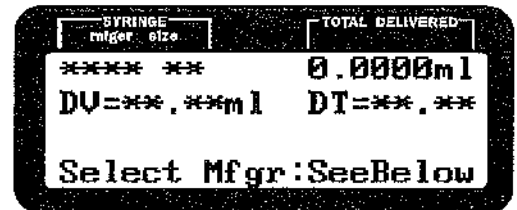

Press ENTER to program your selection.

NOTE: The syringe manufacturer appears on the LCD and the pump automatically advances to the next programmable item.

NOTE: Turn the main power off and start over to correct an inadvertent misentry of the Syringe Manufacturer. A correction is possible only if **SELECT MANUFACTURER** appears on the LCD.



WARNING: Verify that the syringe manufacturer on the LCD is the same as the syringe in use. Failure to use the listed manufacturer could result in inaccurate delivery. The pump cannot automatically identify syringe manufacturer.



In this example **MONO** was entered.

STEP 3: PROGRAMMING SYRINGE SIZE

The fourth line of the LCD alternately flashes "Load Syringe — Press enter."

If the syringe is not already loaded onto the pump, load the syringe as instructed (see Section IV, Operating Instructions).

Once the syringe is properly loaded, press the ENTER key. The pump will automatically enter the correct syringe size and advance to the next programmable item, unless use of the B-D luer lock syringe was selected in custom programming in which case the operator must select syringe size (i.e., 1cc or 3cc). (See Appendix V)

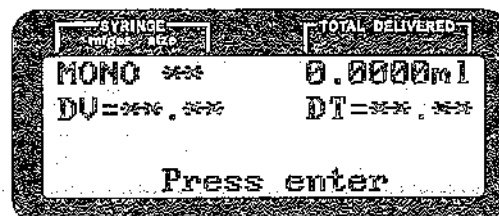
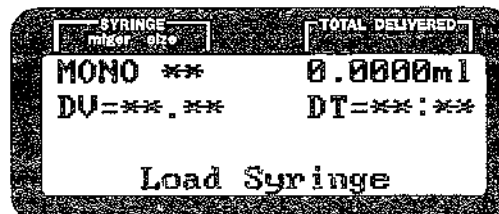

WARNING: Always confirm that the syringe size stated on the LCD agrees with the size of the syringe loaded on the pump. Failure to select the correct syringe size will result in inaccurate delivery.



WARNING: If the B-D luer lock option was selected in custom programming, the operator must select the appropriate syringe size (i.e., 1cc or 3cc). The pump cannot distinguish between these syringe sizes.



STEP 4: PROGRAMMING DOSE VOLUME (DV)

Press the appropriate RATE SELECTION key(s) to program a DOSE VOLUME (DV).

NOTE: Continuously pressing the RATE SELECTION key(s) automatically advances the number.

NOTE: The pump can be programmed to deliver a volume of 0.05 ml with the stipulation that the calculated rate must be equal to or greater than the minimum allowable rate for the chosen syringe size.

Press ENTER key to enter the desired DV. The LCD automatically advances.

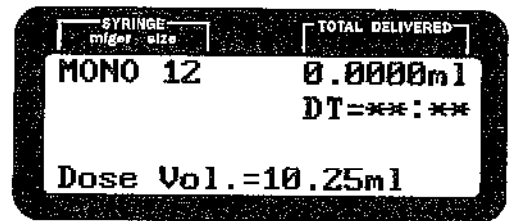
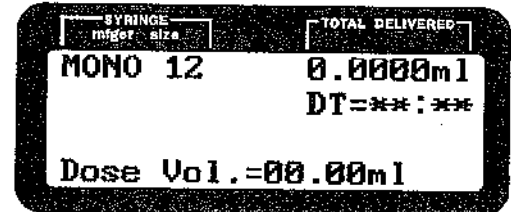

STEP 5: PROGRAMMING DELIVERY TIME (DT)

Press the appropriate RATE SELECTION key(s) to program a DELIVERY TIME (DT). (e.g., Hours:Minutes).

NOTE: Continuously pressing the RATE SELECTION key(s) automatically advances the number.

NOTE: Time entries in minutes equal to or exceeding 60 [i.e., 00:60 to 00:99] are converted to hours [i.e., 01:00 to 01:39]. The time entry, then, must be confirmed by pressing the ENTER key.

Press ENTER key to enter the desired DT. The LCD automatically advances.

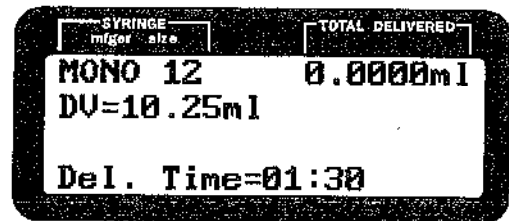
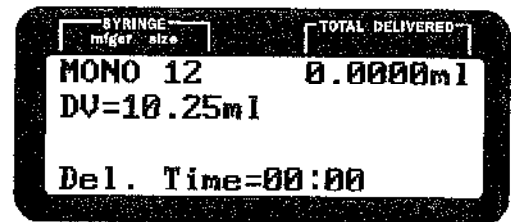

USER MODES continued...

Volume/Time

NOTE: *INVALID NUMBER* displays on the LCD when an invalid rate entry occurs. The fastest possible infusion time will appear for the DV selected.

The pump automatically calculates the rate and all information on the LCD is solid (not flashing). The operator should PRIME to remove any mechanical slack before commencing delivery.

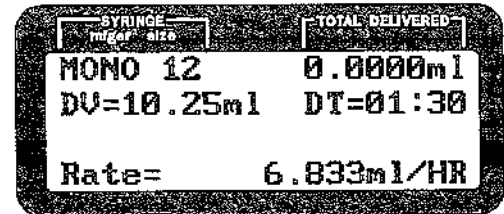

STEP 6: PRIMING

For important detailed information on priming please see section "PRIME".

STEP 7: DELIVERY

Press the DELIVER key to begin the infusion. The LCD will not flash and the green LED DELIVER light begins to blink.

The RUNNING VOLUME (RV) will not appear on the LCD until delivery begins.

In the DELIVERY MODE, all keys are inactive for programming except the ALARM ON/OFF key, the BOLUS DELIVERY key(s) provided a BOLUS was programmed, and the RATE SELECTION key(s).

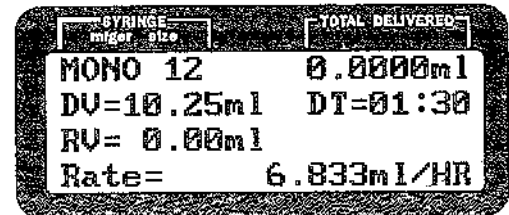

STEP 8: RUNNING VOLUME

The RV in hundredths of a ml will be displayed on the LCD.

NOTE: *The RV records how much of the DOSE VOLUME (e.g., VOLUME LIMIT) has been delivered.*

The RV is reset to zero when any of the following events occur: change in syringe size, empty alarm, reprogram the DV and when PRIME is used.

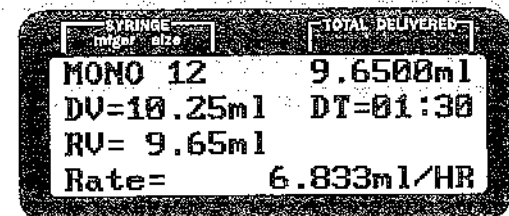

USER MODES continued...

Volume/Time

STEP 9: STOP/END DELIVERY STEP 9A: STOP DELIVERY



Press the STOP/PROGRAM key to stop the infusion. The STOP/PROGRAM LED blinks and a slow intermittent #1 audio alarm sounds.

NOTE: Alarms (e.g., occlusion, depleted battery, syringe pops out) interrupt delivery. Correct the alarm and press the DELIVER key to resume.

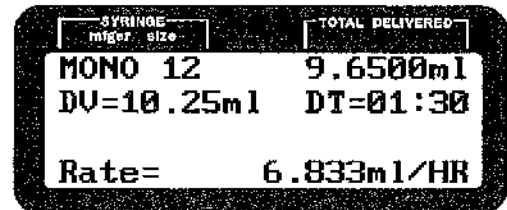

STEP 9B: END OF DELIVERY

When the DV is reached, the number 2 audio alarm sounds. The LCD reads "DOSE VOL DELIVERED - Press Enter" and the STOP/PROGRAM LED blinks indicating delivery cessation. To silence the audio alarm, press the ALARM OFF/ON key.

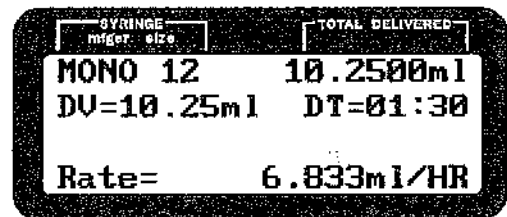

NOTE: The DV only equals the TOTAL DELIVERED readout during the administration of the first infusion. To continue the infusion, press DELIVER. The RUNNING VOLUME resets to zero (RV=0.00ml) and another dose can be given. For example, if two DV amounts are delivered, the TOTAL DELIVERED amount will equal twice the DV amount.

STEP 10: PROGRAMMING STANDBY TIME

The STANDBY MODE allows temporary suspension of an infusion while retaining all pertinent data (e.g., rate, total delivered, syringe size, syringe manufacturer, etc.)

See Section "STANDBY MODE" for detailed information on programming and cancelling STANDBY TIME.

SECTION VI

MULTIMODE PROGRAMMING/OPERATING FEATURES

BOLUS DELIVERY

To administer a **BOLUS** the pump must be delivering.

- ▶ Press both the **BOLUS** and **PRIME** key(s) at the same time. The **BOLUS AMOUNT** delivered will be continuously updated on the **LCD** and the bolus deliver **LED** lights.
- ▶ Once the **BOLUS AMOUNT** has been delivered the pump will resume the previously programmed rate.

REPROGRAM A BOLUS AMOUNT

To reprogram a **BOLUS AMOUNT**, follow method 1 or 2.

METHOD 1

- ▶ Press the **STOP/PROGRAM** key to stop the delivery.
- ▶ Press the **BOLUS** key to get the **BOLUS AMOUNT** to flash.
- ▶ Press the **RATE** key(s) to change the **BOLUS AMOUNT**.
- ▶ Press the **ENTER** keys to enter a new **BOLUS AMOUNT**.
- ▶ Press the **DELIVER** key to reestablish continuous infusion.

METHOD 2

- ▶ Press the **STOP/PROGRAM** key to stop the delivery.
- ▶ Press the **SELECT** key to get the **CONCENTRATION** to flash. Press **ENTER** to confirm **CONC** and to get the **BOLUS** to flash.
- ▶ Press the **RATE** key(s) to change the **BOLUS AMOUNT**.
- ▶ Press the **ENTER** keys to enter a new **BOLUS AMOUNT**.
- ▶ Press any **RATE** key to change rate.

or

- ▶ Press **ENTER** to reconfirm rate (**LCD** will not flash).
- ▶ Press the **DELIVER** key to reestablish continuous infusion.

Multimode Programming/Operating Features Continued...

TEMPORARILY DEPROGRAMMING BOLUS AMOUNT

METHOD 1

Follow either Method 1 or 2 as described above. Enter a **BOLUS** Amount of all 0's.

METHOD 2

To deprogram a **BOLUS AMOUNT** press the **STOP/PROGRAM** key to stop delivery.

- Press **PROTOCOL/DECIMAL** key - **BOLUS AMOUNT = YES** will flash on LCD.
- Press the **SELECT** key to change **YES** to **NO**.
- Press the **ENTER** key to enter.
- Press **DELIVER** to reestablish continuous infusion.

Multimode Programming/Operating Features Continued...

CHANGING THE RATE

The operator can change the infusion **RATE** by two methods:

① STOP THE PUMP

- ▷ Press **STOP/PROGRAM**.
- ▷ Press the **RATE SELECTION** keys to start rate flashing; program a new rate.
- ▷ Press the **ENTER** key.
- ▷ Press the **DELIVER** key.

OR

② DON'T STOP THE PUMP

- ▷ Press any **RATE SELECTION** key and when rate flashes;
- ▷ press **RATE** key to readjust existing rate to new **RATE**.
- ▷ Press **ENTER** to change to the newly programmed **RATE**.

Multimode Programming/Operating Features Continued...

PRIME

Press and hold the **PRIME** key to purge air from the administration set. The **LCD** states "**PRIME VOL = 00.00ML**" and the pump runs at its fastest rate. After approximately 16 seconds elapse, a continuous tone (#3) sounds. However, the pump continues to prime when the key is held down.

Prime Vol= 00.00ml

prime

The amount delivered while priming is **NOT** counted by the **TOTAL DELIVERED** counter. However, the amount delivered is shown on the prime volume counter.

Prime Vol= 00.30ml

The **PRIME** function only activates when the pump is in the **STOP/PROGRAM MODE** and all other functions are entered (e.g., Syringe Manufacturer, Syringe Size, Bolus Amount and Rate).



CAUTION: The prime function should be utilized when placing a newly filled syringe on the pump or when attaching an infusion set. Priming will displace the air in the set with the infusate and removes mechanical slack before starting delivery. This assures that the syringe driver and plunger are in contact.



WARNING: Do not operate the pump in the prime function while connected to the patient. This could cause over-delivery of infusate or an infusion of air purged from the set.

NOTE: When priming, the occlusion alarm may occur if a small bore Mini-vol™ extension set is used. Intermittently press and release the **PRIME** key (versus pressing and holding it continuously) to alleviate this problem.

Multimode Programming/Operating Features Continued...



WARNING:

PROGRAMMING STANDBY TIME

If the "some" alarm selection was made in the custom program mode, the **STOP/PROGRAM** audio alarm was disabled, therefore *an audio alarm will not occur when the **STANDBY TIME** elapses* in the **STANDBY MODE**.

The **STANDBY MODE** allows temporary suspension of an infusion while retaining all pertinent data (e.g., rate, total delivered, syringe size, syringe manufacturer, etc.). The **STANDBY TIMER** delays the occurrence of the **STOP/PROGRAM** audio alarm by the time programmed.

- ▷ Press the **STOP/PROGRAM** key to stop the infusion. The pump must be in the **STOP/PROGRAM** mode. Press at the same time the **STOP/PROGRAM** and **ENTER** keys then release both.

- ▷ The last line of the **LCD** will appear as shown.

- ▷ Press the **ENTER** key. The **LCD** displays "**STBY Time=00:00**"

- ▷ Program the desired **STANDBY TIME** in hours and minutes (e.g., 03:30 for three hours and thirty minutes) with the **RATE** keys.

NOTE: Time entries in minutes that equal or exceed 60 [i.e., 00:60 to 00:99] are converted to hours [i.e., 01:00 to 01:39]. The time entry then must be confirmed by pressing the **ENTER** key.

- ▷ Press **ENTER** to start the timer. The **LCD** states "**STBY Time = 03:30**". The time shown on the **LCD** will begin to count down.

NOTE: When the **STANDBY TIME** elapses, "**STBY Time = 00:00**" disappears from the screen, the **STOP/PROGRAM** audio alarm sounds and the previously programmed rate reappears.

- ▷ Press the **DELIVER** key to begin delivery.

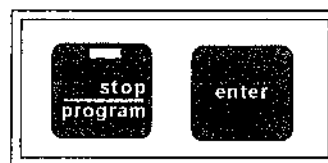

<sel>/<ent>:Stand-by



STBY TIME= 00:00

STBY TIME = 03:30



STBY TIME = 03:30

STBY TIME= 00:00



Multimode Programming/Operating Features Continued...

CANCELLING THE STANDBY TIME

- ▷ Press the **STOP/PROGRAM** key to return the pump to the previously programmed setting.

- ▷ Press the **DELIVER** key to begin delivery.



SECTION VII

OTHER KEY FUNCTIONS

A. ALARM OFF/ON

To temporarily silence an audio alarm, press the **ALARM AUDIO OFF/ON** key. The alarm stops but the appropriate **LED** remains lit. After approximately 2 or 60 minutes, the audio alarm automatically turns back "**ON.**" (The time delay of 2 or 60 minutes is custom programmed at the factory or by qualified biomedical personnel.) To accomplish reactivation of the audio alarm, press the **ALARM OFF/ON** key for a second time. **The only exception to this is the low battery alarm. If this alarm is silenced, it will not be reactivated in 2 or 60 minutes, i.e., the alarm OFF/ON permanently silences this alarm.**

NOTE: *The SYSTEM MALFUNCTION alarm is only silenced by turning off the main power.*

B. RESET TOTAL VOLUME DELIVERED

The **RESET TOTAL DELIVERED** key is active only when the pump is in the **STOP/PROGRAM** mode. To **RESET** the **TOTAL DELIVERED** to 0.00, press the key. Each time the main power is switched "**ON,**" the **TOTAL DELIVERED** automatically zeros.

C. PROTOCOL/DECIMAL

This key has a dual function depending on the rate mode selected. In the **BODY WEIGHT MODE**, the **PROTOCOL** key permits one to select the desired rate mode (e.g., mcg/kg/min, mcg/kg/HR, etc.) in the **STOP/PROGRAM** mode. In all modes except **VOLUME/TIME** one can use the key to shift the decimal point for various parameters (e.g., concentration, weight and infusion rate).

D. BOLUS DELIVERY

In order to administer a **BOLUS**, press at the same time both the **BOLUS** and **PRIME** keys.

E. RATE SELECTION KEY

Used to enter values including concentration, weight, rate, time and volume. Simultaneously pressing any two rate selection keys resets the parameter to 0 in cases of inadvertent misentry.

F. PUMP POWER SWITCH

Used to turn the pump **ON** (I) and **OFF** (O).

SECTION VIII

ALARMS/ALERTS

A. INTRODUCTION

The pump incorporates a series of ALARMS which are depicted in Table I.

NOTE: Review Section VIII (Other Key Functions) for specifics on how the ALARM OFF/ON key functions.

B. PROCEDURE FOR CORRECTING OCCLUSION ALARM

Troubleshoot by first checking for:

1. Kinks in tubing
2. Stopcocks and clamps which are turned off—prohibiting flow
3. Clotted IV catheter or needle
4. Something preventing movement of the Syringe Driver
5. Make sure syringe is not empty

Press the DELIVER key to restart the infusion once the occlusion is relieved/corrected.

NOTE: The pump *STOPS INFUSING* if an occlusion alarm occurs.



WARNING: When an occlusion occurs and is corrected, there is a risk of infusing the pressurized build up of infusate. To avoid inadvertent Bolus, relieve the pressure before restarting the infusion.

C. PROCEDURE FOR CORRECTING SYSTEM MALFUNCTION

This alarm indicates that something has disrupted the operation of the microprocessor. Failures, which would activate this alarm, are over and under deliveries and electrical component failures.



WARNING: If this alarm occurs, remove the pump from service and consult the manufacturer. Also, record any operating data such as Total Volume Delivered, Infusion Rate, syringe manufacturer, syringe size, etc. Once the pump is turned OFF, this information is NOT retained.

D. NEAR EMPTY ALARM

Under most conditions, the NEAR EMPTY ALARM automatically sounds as 3 beeps approximately 10 minutes before the syringe becomes physically empty. The pump continues to deliver after the NEAR EMPTY alarm sounds. However, be aware of the following: If a volume limit is programmed and is less than the fluid in the syringe, the volume limit alarm will sound at the appropriate point and the infusion will stop. If a volume limit is programmed to be larger than the fluid remaining, a NEAR EMPTY alarm and EMPTY alarm will sound at the end of the syringe. No Volume Limit alarm will sound. If a volume limit value just slightly less than the volume of fluid in the syringe is programmed as a volume limit, the near empty alarm will sound, then the volume limit alarm may sound.

ALARMS/ALERTS continued...

E. EMPTY ALARM

The EMPTY ALARM'S actuation point is determined by a mathematical formula based on the Syringe Manufacturer and Syringe Size. Whenever an EMPTY ALARM sounds (Alarm #2), the operator should visually verify that the syringe in use is EMPTY. The operator must decide to terminate the infusion or replace the syringe with a new supply of infusate.

NOTE: *The pump stops delivering when the EMPTY ALARM SOUNDS. The audio #2 alarm may be temporarily silenced by pressing the ALARM OFF/ON key.*

If the syringe has any fluid remaining to deliver, restart the infusion by pressing the DELIVER key. The NEAR EMPTY ALARM will sound and when the syringe is empty you will receive a second EMPTY ALARM. **NOTE: THAT THE RV IS RESET BUT THE TOTAL VOLUME IS CUMULATIVE.**

F. SYRINGE POPS OUT

This alarm occurs if the syringe is disturbed during the infusion. A type 3 or continuous alarm sounds and the fourth line of the LCD alternates between "PRESS enter" and "SYRINGE POPS OUT!"

To correct, confirm that the syringe is loaded properly, then press ENTER to verify syringe size. Press DELIVER to continue the infusion.

The audio alarm is temporarily silenced by pressing the ALARM OFF/ON key.

G. CHECK CLUTCH

This alarm occurs if the clutch is not engaged to the SYRINGE DRIVER. A type 3 or continuous alarm sounds and the fourth line of the LCD alternates between "PRESS enter" and "CHECK CLUTCH!!"

To correct, make sure the clutch is fully engaged and that the syringe is properly loaded. Press "ENTER" to confirm clutch check and then DELIVER to continue the infusion. The audio alarm is temporarily silenced by pressing the ALARM OFF/ON key. If the clutch is manually disengaged for a period of time or the driver is manually moved during delivery a "CHECK CLUTCH" alarm results.

H. INVALID SIZE

This alarm occurs if the syringe loaded on the pump is not the size which is stored in the pump. In addition, please note that the pump **cannot** distinguish between the same size syringe for different manufacturers.

To correct, confirm that the syringe manufacturer programmed is the same as the syringe being utilized. Also verify that the area between the syringe barrel and SYRINGE CLAMP is kept clear of labels, etc. and that the syringe finger tabs are oriented as described in this manual.

ALARMS/ALERTS continued...

I. INVALID NUMBER

This LCD message occurs with entry of a parameter which cannot be accepted by the computer. Two beeps sound and the first valid number is displayed. For example: a rate too fast for the syringe selected, a volume limit greater than the volume of the syringe selected, if the Time Between Doses is less than or equal to the Delivery Time, in V/T where the desired delivery time is too fast for the volume chosen, etc.

J. LOW BATTERY

The low battery alarm occurs approximately 30 minutes before battery depletion at rates of 5 cc/hr or less. The low battery LED lights and two beeps occur intermittently every 15 seconds. The audio alarm may be permanently silenced by pressing the alarm On/Off key once. The LED will remain on.

K. OCCLUSION SENSING

The Medfusion 2010 syringe pumps can operate at variable sensitivities to occlusion. The occlusion sensitivity set at the manufacturer (unless otherwise specified) is normal. Three other options exist for the force setting including "LOW", "INT", "MID", and "HIGH". The best options may be selected for the specific clinical application.

To change the force setting on the 2010 syringe pumps consult the manufacturer, the service manual or Medex-certified biomedical personnel.

For software version 1.2, if LOW, INT, MID, HIGH are selected the syringe size will be followed by an L, I, M, H respectively so the operator will be able to identify the proper force table. For software version 1.21 (or higher), MID has been changed to INT or I.

The PSI setting is theoretically derived. Generally the actual PSI will be lower than the theoretical value. The actual output pressure is affected by a multiplicity of factors including syringe size, friction between syringe barrel and plunger, catheter gauge, internal diameter of the tubing, durometer of the tubing, residual volume of tubing, rate of infusion, use of various in-line devices including stopcocks/filters/valves, etc. For example, making changes to the force setting with use of a Monoject 35cc syringe affects the following:

	Monoject 35cc syringe:	
Normal	11.0 force (lbs)	16.4 max theoretical psi
Low	4.0 force (lbs)	5.96 max theoretical psi
Intermediate	6.88 force (lbs)	10.2 max theoretical psi
Middle	13.8 force (lbs)	20.5 max theoretical psi
High	15.0 force (lbs)	22.3 max theoretical psi

For further information on theoretical values for other syringe sizes/settings, please contact Medex's Technical Services.



IMPORTANT: Any setting may produce false occlusion alarms, however, in general the lower occlusion pressures are more likely to create false occlusion alarms.

ALARMS/ALERTS *continued...*

L. PLUNGER SENSOR/OCCLUSION

Medfusion 2010 pumps subsequent to serial number 33601 and all pumps that have had the plunger holder/track subassembly replaced with the plunger/track - 2 subassembly and the slide housing - 2 subassembly have a number of changes to the track subassembly. The retainer moves outward when the clutch is pinched. Additionally, dependent upon the software version, an alarm occurs when the plunger is not in place.

For software versions 1.2 and lower an "occlusion" alarm triggers during the size confirmation sequence in pump programming or during delivery if the plunger is not properly loaded. For software versions higher than 1.2, a LCD message "LOAD SYRINGE PLUNGER" occurs in the same scenario. In both cases, a continuous alarm occurs and the plunger should be placed into the retainer.

As with all occlusion alarm occurrences, the user should check for all sources of occlusion and for 1.2 software versions and lower, the lack of plunger placement should be considered as a source. The user is cued to do same via labelling as follows:

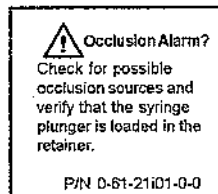

TABLE I

ALARM/ALERT GRID FOR MODEL 2010

ALARM OR ALERT	AUDIO (A)	TEMP. AUDIO OFF (B)	VISUAL LED (C)	AUTO. ADJUSTED	LCD MESSAGE	DEF. TO STOP/ PROG	INFUSION AUTO. STOPS	WHAT TO DO
STOP/ PROGRAM	#1	YES	YES AT SWITCH (R)	N/A	NONE	N/A	YES	PROGRAM OR TURN PUMP OFF
NEAR EMPTY	3 beeps	N/A	YES (Y)	YES - Approx. 10 min. from empty point	NONE	NO	NO	PREPARE TO TERMINATE INFUSION OR LOAD A NEWLY FILLED SYRINGE
EMPTY	#2	YES	YES (R)	YES	NONE	YES	YES	TERMINATE INFUSION OR LOAD A NEWLY FILLED SYRINGE
BOLUS DELIVERY	NONE	N/A	YES (Y)	N/A	Bolus Armt =	NO	NO	N/A
OCCCLUSION	#3	YES	YES (R)	YES	NONE	YES	YES	CORRECT PROBLEM AND PRESS DELIVERY TO RESTART INFUSION
SYSTEM MALFUNC.	#3	NO must turn off main power	YES (R)	NONE	System Error	YES	YES	REMOVE UNIT FROM SERVICE AND CONSULT MANUFACTURER
LOW BATTERY	Two quick #1 with 15 sec. delays	* Permanent	YES (Y)	YES - Approx. 30 min. power remain	NONE	NO	NO	PLUG INTO MAIN AC AS SOON AS POSSIBLE
DEPLETED BATTERY	#3	YES	YES (R)	N/A	Bat. Depl/ Plug In AC	YES	YES	Pump cannot infuse unless plugged into AC—Allow time for battery to recharge
BATTERY IN USE	NONE	N/A	YES (Y)	N/A	NONE	N/A	NO	INFORMATION ONLY
BATTERY CHARGING	NONE	N/A	YES (G)	N/A	NONE	N/A	NO	INFORMATION ONLY
SYRINGE POPS OUT	#3	YES	NO	N/A	Syringe Pops Out	YES	YES	RE-ENTER SYRINGE SIZE
PRIMING	#3 (16 second delay)	NO	NO	N/A	Prime Vol =	N/A	N/A	N/A
DELIVER	NONE	N/A	YES AT SWITCH (G)	N/A	NONE	N/A	N/A	N/A
VALID KEY PRESS	ONE PECK	NO	N/A	N/A	N/A	N/A	N/A	N/A
CHECK CLUTCH	#3	YES	NO	N/A	Check Clutch!	YES	YES	Press ENTER then DELIVER. If alarm recurs, consult service manual or qualified biomedical personnel. (See 'D' below).

(A) ALARM AUDIO #1 IS SHORT BEEPS WITH LONG INTERVALS; #2 SHORT FAST BEEPS; #3 CONTINUOUS TONE
 (B) TEMPORARY AUDIO OFF RESETS TO AUDIO ON AFTER 2 MINUTES OR 60 MINUTES (OFF-LINE PROGRAMMABLE) OR THE AUDIO CAN BE TURNED BACK ON BY PRESSING THE AUDIO OFF/ON KEY FOR A SECOND TIME.
 (C) DENOTES LED COLOR (E.G. (G) GREEN; (R) RED; (Y) YELLOW).
 (D) A CHECK CLUTCH ALARM OCCURS IF THE TRACK DOES NOT MOVE AT THE PROPER SPEED ACCORDING TO THE RATE SET ON THE PUMP. IF THE DRIVER IS MOVED MANUALLY DURING DELIVERY A CHECK CLUTCH ALARM OCCURS.

N/A = NOT APPLICABLE

* Alarm will not reactivate once alarm ON/OFF is pressed.

SECTION IX

BATTERY POWER

- A. The pump's batteries simultaneously recharge while operating and while the pump is turned OFF but plugged into AC. The batteries cannot be overcharged. The BATTERY CHARGING LED indicates that electricity is reaching the batteries.
- B. If the LOW BATTERY LED lights and an audio alarm occurs while the pump is running, the pump should be placed on AC as soon as possible. However, the pump's operation is not compromised in any way while operating in the low battery state.
- C. If the pump is allowed to reach DEPLETED BATTERY, the LED will flash and #3 audio alarm will sound. The pump is no longer able to continue operating. To continue the infusion, the pump must be plugged into the wall.
The LCD appears as described below.
- D. If a low or depleted battery condition exists upon turning the pump ON, the LCD will state:

Bat. Depl/Plug in AC

The pump must be plugged into AC and the DELIVER key pressed before commencing operation.

- E. The LCD backlight is normally off when the pump is operating on battery power. With activation of the BACKLIGHT key or any other key on battery power, the BACKLIGHT stays on for 15 seconds. The backlight is always lit when the pump is operating on AC power.
- F. To display the battery recharge time, press and hold both the STOP/PROGRAM and DELIVER keys, then turn the pump on.

Both the recharge time and battery voltage continuously display. The battery voltage displays after a 60 second delay.

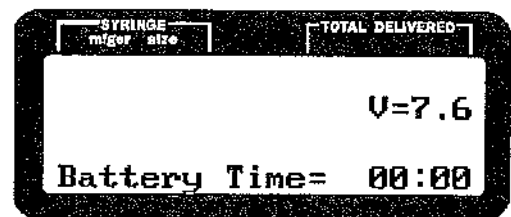

FOR EXAMPLE:

This display indicates the batteries have been recharging for ten hours seventeen minutes and the present battery voltage is 8.0.

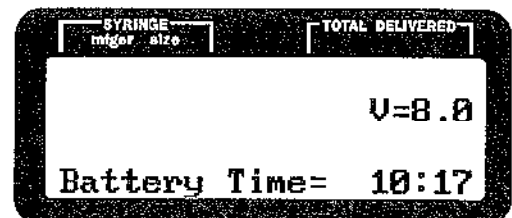

SECTION X

BATTERY VOLTAGE

- A. To check the charge status of the batteries
1. Unplug the AC adaptor
 2. Turn the pump ON
 3. Review the voltage stated on the LCD

BAT.V=7.8

A voltage greater than 8.2 volts indicates a nearly FULL CHARGE; however, the pump should be recharged for 16 hours to insure a FULL CHARGE. A voltage less than 7.3 volts indicates a LOW BATTERY condition.

SECTION XI

IV POLE OR RAIL ATTACHMENT

A. INTRODUCTION

All pumps can easily accept the POLE CLAMP or the ROTATING POLE CLAMP using the procedures described below.

B. ATTACHING POLE CLAMPS

1. Orient the POLE CLAMP either vertically (for IV pole mounting) or horizontally (rail mounting). Use the two #6-32 flat head screws provided to secure the IV clamp to the back of the pump.

2. The ROTATING POLE CLAMP is designed to provide maximum flexibility when mounting or transporting your syringe pump. Special features include a quick release lock and full pump rotation capabilities.

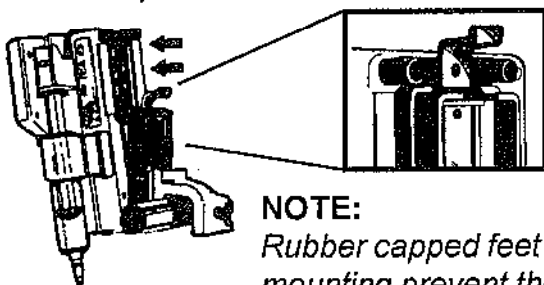

NOTE:

Rubber capped feet on the mounting prevent the pump from sliding when placed on a counter top or isolette.

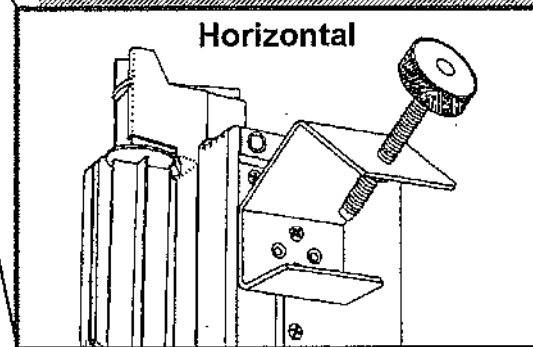
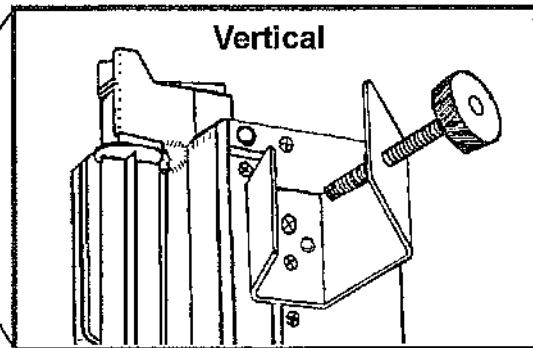
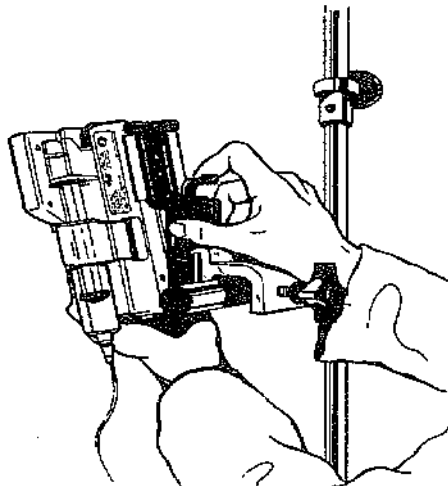

- a. **ATTACHING THE MOUNTING PLATE**
The Pole Clamp Mounting Plate is secured to the pump with two flat head screws provided by the manufacturer.
- b. **ATTACHING AND REMOVING THE PUMP FROM THE POLE CLAMP ASSEMBLY**

To attach the pump to the Pole Clamp Assembly, slide the Mounting Plate down into the grooves on the assembly until the Release Latch locks into place.

The pump may be quickly and easily removed from the assembly by gently pulling back on the Release Latch and sliding the pump up and out of the grooves.

IV POLE OR RAIL ATTACHMENT *continued...*

c. ROTATING THE PUMP ON THE POLE CLAMP

When attached to the Pole Clamp Assembly, the pump can be rotated to better suit its environment. To rotate the pump, grasp it firmly and turn it in the desired direction. You feel the pump stop and lock into four different positions: Straight Up, 90 degrees to the right, Up-side Down and 90 degrees to the left.

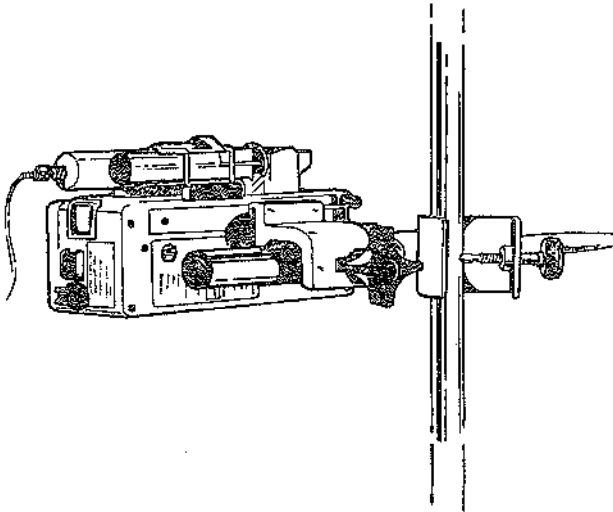

d. PERMANENTLY ATTACHING YOUR PUMP TO THE POLE CLAMP

To permanently affix the pump to the Pole Clamp Assembly, slide the Mounting Plate into the assembly, then attach the entire unit to the pump with flat head screws (Consult Technical Services at manufacturer for further information).

3. ADDITIONAL ACCESSORY - CATALOG NO. 2001-TB

Also available from Medex is a "T" bar multiple pump pole mount pictured below. In addition to multiplying the capacity of one I.V. pole for the multiple pumps, it allows orientation of the 2000 Series pump for easy visualization.

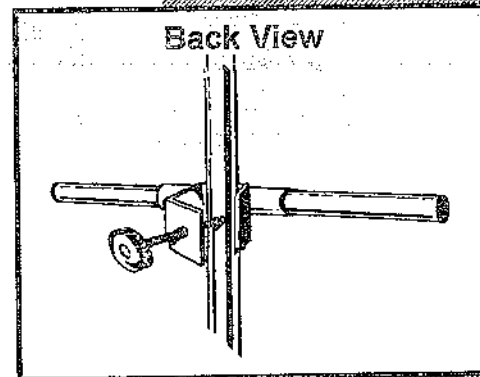
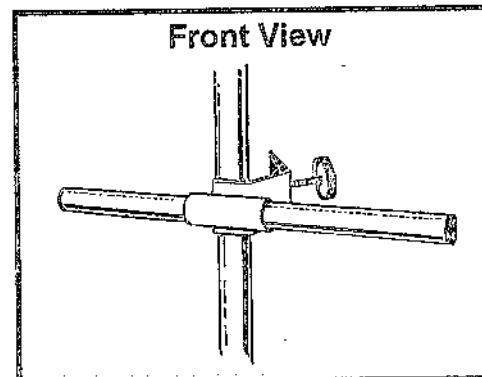
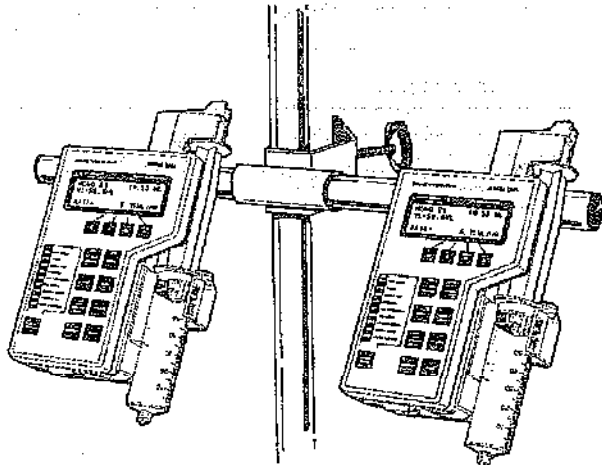

SECTION XII

PRECAUTIONS



WARNING

1. This pump is for use only the under direction of qualified medical professionals.
2. Verify all programmed settings PRIOR to initiating delivery.
3. Verify that both the manufacturer of the syringe in use and the syringe size coincide with the information displayed on the LCD display.
4. Purge all air from the syringe and infusion lines BEFORE connecting to patient.
5. Do not place any labels on the syringe that will be covered by the syringe retainer clamp. This clamp must contact the syringe barrel without interference to ensure accurate syringe size sensing.
6. Do not use in presence of flammable anesthetics or explosive gases (i.e. in laboratories or in operating rooms where explosive gases are present).
7. Always use PRIME when mounting a newly filled syringe to remove any mechanical tolerances. Failure to do so may delay the delivery of the infusate and cause the TOTAL VOLUME DELIVERED display to read higher than actually delivered to the patient.
8. Medex recommends use of syringes as indicated in the General Specifications Section. Contact Medex for use of other syringes.
9. If the pump fails to perform as described herein, remove from service and consult Medex.
9. Selection of the "some" alarm option silences the audio component for the following alarm conditions: STOP/PROGRAM (includes standby mode), NEAR EMPTY, EMPTY and VOLUME LIMIT.
11. When an occlusion occurs and is corrected, there is a risk of infusing the pressurized build up of infusate. To avoid inadvertent bolus, relieve pressure before restarting the infusion.
12. Verify that the syringe manufacturer on the LCD is the same as the syringe in use. Failure to use the listed manufacturer could result in inaccurate delivery. The pump cannot automatically identify syringe manufacturer.
13. Always confirm that the syringe size stated on the LCD agrees with the size of the syringe loaded on the pump. Failure to select the correct syringe size will result in inaccurate delivery.
14. If the B-D luer lock option was selected in custom programming, the operator must select the appropriate syringe size (i.e., 1cc or 3cc). The pump cannot distinguish between these syringe sizes.

PRECAUTIONS continued...

13. If the pump has been dropped or damaged, it must be thoroughly examined and tested to assure that it is functioning properly. Failure to do so could result in either under or over delivery of medication along with the resulting consequences.
14. Do not expose the pump to strong magnetic fields as it may affect pump function.
15. It is recommended that this pump not be used in situations where the syringe is connected to a system much less than atmospheric pressure (i.e., negative pressure below -100 mmHg). At certain pressures, the plunger could be pulled from the retainer resulting in a siphoning situation and the resulting complications of an overdelivery, which could include serious injury or death.

CAUTION:

1. Always verify carefully that the syringe is mounted properly. The finger tabs should be secured by the syringe clamp and the syringe plunger end by the syringe driver retainer. For 60cc syringes, be sure the finger tabs of the syringe engage the syringe clamp groove (retainer) and the syringe saddle. Rotating the syringe barrel will improve engagement. If not properly engaged, the pump may alarm after it has been in the deliver mode for a period of time.
2. Do not allow fluids to enter the pump. Immediately wipe off all spills.
3. The TOTAL VOLUME DELIVERED and the VOLUME LIMIT use separate counters.
4. Do not use organic solvents to clean the pump. Use only those agents listed under "cleaning" to clean and disinfect the pump. Use of unapproved agents could damage the pump (See cleaning agent section).
5. Do not autoclave or subject the pump to temperatures which exceed 50 degrees C.
6. Use only those drugs which are compatible with the disposable syringe selected and the existing environmental conditions.
7. Verify that the model number and software version of the pump and the operations manual agree.
8. In the VOLUME/TIME mode, the pump may be programmed to deliver as little as 0.05 ml, however, the calculated rate must be greater than or equal to the minimum allowable rate for that particular size of syringe.
9. In consideration of how syringe pumps operate, clinicians should consider use of appropriate syringe, tubing, and in-line devices for the given application and the drug being infused. Certain factors enhance multiple characteristics of syringe pump infusion such as time to detect an occlusion, visual verification of volume delivered, continuity of flow, time to reach the set rate. Following are considerations requiring discretion by clinicians using syringe pumps. (Typically, this is most important with continuous injections of short half-life drugs.)

PRECAUTIONS continued...

- a. Select the smallest syringe size appropriate for the intended application. Friction within the syringe (between the plunger rubber tip and the barrel) can affect the continuity of flow and the time required to attain the set infusion rate; the plunger tip expands and relaxes throughout the infusion, particularly with larger syringes at slower rates. The best case is to use smaller syringes at higher rates.
 - b. Do not use a 60 cc syringe for rates of 2.0 cc/hour or less. Such use is generally not recommended when using a syringe pump.
 - c. Connect the syringe pump tubing at the closest point to the patient for more predictable and accurate delivery of the fluid.
 - d. Use small internal diameter, high hardness tubing and no in-line devices for best results at low rates.
10. A routine preventive maintenance schedule should be followed according to the policy defined by the individual hospital. Presently, Medex recommends that these procedures be performed as indicated in the Service Manual. Additional routine cleaning and inspections should be performed on an as needed basis (i.e., droppage, fluid contamination, suspect malfunction, etc.).



IMPORTANT:

On the front of this manual is a revision date. If the date is over three (3) years, please contact Medex to see if additional information related to this product is available.

SECTION XII

CLEANING

The pump housing may be cleaned with the following agents:

AMMONIA and 97% water
CLOROX and 90% to 95% water
CONTROL III (by Maril Products, Inc.)
COLD SPOR (by Metrex Research Corporation)
DETACHOL (by Fernedale Laboratories, Inc.)
ENVY (by S. C. Johnson & Son, Inc.)
ENZOL (by Johnson & Johnson Medical, Inc.)
ETHYLALCOHOL 95% (190 proof)
HARCO TINCTURE OF GREEN SOAP (by Harley
Chemicals)
ISOPROPYLALCOHOL 70% (rubbing alcohol)
ISOPROPYLALCOHOL 70% and 10% ACETONE

LpH, se (by Calgon Vestal Laboratories)
MANU-KLENZ (by Calgon Vestal Laboratories)
METRIZYME (by Metrex Research Corporation)
MILD SOAP AND WATER SOLUTION
NUTRA-pH (by Snowden-Pencer)
SANI-CLOTH (by distributor: Professional
Disposables, Inc.)
SEPTISOL (by Calgon Vestal Laboratories)
SPORICIDIN (by Calgon Vestal Laboratories)
TOR-II (by Huntington Laboratories, Inc.)
WISKADHESIVE REMOVER PAD (by Baxter
Healthcare Corporation)

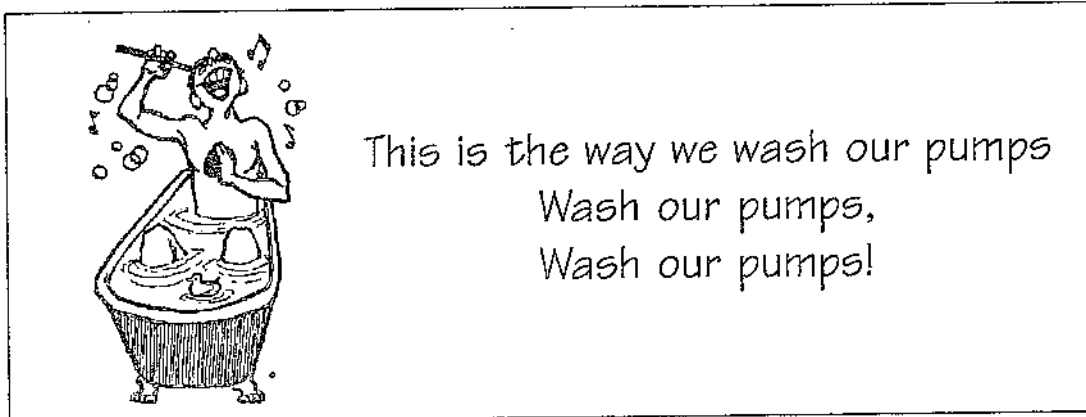

CAUTION:

Recommendations for agents applies to compatibility of agent with the plastic housing and is not based on the cleansing/disinfecting ability or effectiveness. Medex makes no representations as to any agent's ability to cleanse or disinfect. We defer to the guidelines of the manufacturer for mixing instructions for agents listed.



WARNING:

Do not use solutions containing strong detergents, organic solvents, quarternary ammonium or ammonium chloride to clean any portion of the pump, as serious damage could result. **DO NOT IMMERSE.** Avoid spills and inadvertent allowance of fluid in the pump housing.

SECTION XIV

SERVICE AND LIMITED WARRANTY

Other than cleaning, maintenance must be performed by qualified biomedical personnel trained by Medex.

LIMITED WARRANTY

MEDEX, Inc. warrants to the purchaser that the Syringe Infusion Pump shall be free from defects in material and workmanship for a period of one (1) year from the date of purchase. MEDEX'S sole obligation with respect to any such defect is limited to the repair, or at MEDEX's option, replacement of the Syringe Infusion Pump. Purchaser pays return freight charges.

This limited warranty is made on the condition that prompt notification of a defect is given to MEDEX, within the warranty period, and that MEDEX shall have the sole right to determine whether a defect exists.

This limited warranty does not apply to Syringe Pumps that have been partially or completely disassembled, altered, subjected to misuse, negligence, or accident; or operated other than in accordance with the instructions provided by MEDEX.

This limited warranty represents the exclusive obligation of MEDEX, and the exclusive remedy of the purchaser regarding defects in a Syringe Infusion Pump. THIS WARRANTY IS GIVEN IN LIEU OF ANY EXPRESS OR IMPLIED WARRANTIES, INCLUDING THE WARRANTY OF MERCHANTABILITY, OR FITNESS FOR A PARTICULAR PURPOSE. No person is authorized to modify, in any manner, MEDEX'S obligation as described above.

MEDEX reserves the right to make changes in or additions to pumps manufactured and/or sold by MEDEX at any time, without incurring any obligation to make the same or similar changes on pumps previously manufactured or sold by MEDEX.

SERVICE AND LIMITED WARRANTY continued...

SERVICE



CAUTION:

The syringe pump should not be serviced by any personnel who have not attended the 2000 Series Service School.

Other than cleaning, maintenance must be performed by qualified biomedical personnel at the institution or at manufacturer. For questions on repair, service or maintenance of our pumps, please call our **TECHNICAL SERVICE DEPARTMENT** at **1-800-648-0840**.

When returning a pump for service, please consider the following:

- Call Technical Services at 1-800-648-0840 to obtain a RETURN AUTHORIZATION (will need serial number, model number, p.o. #, other pertinent information related to the reason for return).
- Decontaminate the pump or accessory prior to returning to the manufacturer (according to O.S.H.A. guidelines).

NOTE: *If OSHA guidelines are not followed, original packaging cannot be returned.*

- Package unit in original packaging or other appropriately protective shipping container.
- Indicate the Return Authorization Number on the outside of the packaging.
- Ship to **MEDEX** via preferred method (at your cost). Indicate preferred method of return.

APPENDIX I FLOW RATES

SYRINGE SIZE	MFGR	ML PER HR (In Tenths)	
		Maximum	Minimum
1.0	B-D	11.00	0.01
1.0	Mono	11.00	0.01
1.0	Teru	11.00	0.01
1.0	BD-G	10.00	0.01
2.0	BBM	45.00	0.01
3.0	B-D	36.00	0.01
3.0	Mono	39.60	0.01
3.0	Teru	39.60	0.01
3.0*	BD-G	36.90	0.01
5.0	B-D	70.00	0.01
6.0	Mono	80.80	0.01
5.0	Teru	80.80	0.01
5.0	BD-G	70.00	0.01
5.0	BBM	80.00	0.01
10.0	B-D	104.0	0.1
12.0	Mono	126.0	0.1
10.0	Teru	126.0	0.1
10.0	BD-G	104.0	0.1
10.0	BBM	128.0	0.1
10.0	Fres	130.0	0.1
20.0	B-D	182.0	0.1
20.0	Mono	207.0	0.1
20.0	Teru	207.0	0.1
20.0	BBM	205.0	0.1
30.0	B-D	234.0	0.1
35.0	Mono	285.0	0.1
30.0	Teru	270.0	0.1
30.0	BBM	280.0	0.1
50/60	B-D	355.0	0.1
60.0	Mono	356.0	0.1
60.0	Teru	378.0	0.1
50.0	Abot	360.0	0.1
60.0	BBM	370.0	0.1
50.0	Fres	400.0	0.1
60.0	Perf	375.0	0.1

* A 2.5 ml B-D glass syringe is recognized in the software as a 3 ml syringe; therefore, 3 ml is the selection option for a 2.5 ml B-D glass syringe.

** Depending on the location of the decimal point, rates can be programmed in smaller increments (e.g., 0.01, 0.001, 0.0001) provided the minimum rate is exceeded. For example, if the decimal point is placed in the hundredths location on a 60cc MONO syringe, the minimum rate is 00.10. Once the minimum has been satisfied, the operator can program a number in the hundredths place (e.g., 00.15).

*** Syringe manufacturers BBM, FRES, PERF are available only in software version 1.2A.

APPENDIX II

CALCULATIONS

The following formulas are used to calculate various variables in the **BODY WEIGHT** mode and **CONCENTRATION** mode:

RATE MODE = mcg/kg/min

RATE in mcg/kg/min = $\frac{(\text{final conc in MG/ml}) (\text{ml/HR}) (1000)}{(60 \text{ min/HR}) (\text{wt in kilos})}$

RATE in ml/HR = $\frac{(60 \text{ min/HR}) (\text{wt in kilos}) (\text{mcg/kg/min})}{(\text{final conc in MG/ml}) (1000)}$

CONC. in MG/ml = $\frac{(60 \text{ min/HR}) (\text{wt in kilos}) (\text{mcg/kg/min})}{(\text{ml/HR}) (1000)}$

RATE MODE = mcg/kg/HR

RATE in mcg/kg/HR = $\frac{(\text{final conc in MG/ml}) (\text{ml/HR}) (1000)}{(\text{wt in kilos})}$

RATE in ml/HR = $\frac{(\text{wt in kilos}) (\text{mcg/kg/HR})}{(\text{final conc in MG/ml}) (1000)}$

CONC. in MG/ml = $\frac{(\text{wt in kilos}) (\text{mcg/kg/HR})}{(\text{ml/HR}) (1000)}$

RATE MODE = MG/kg/min

RATE in MG/kg/min = $\frac{(\text{final conc in MG/ml}) (\text{ml/HR})}{(60 \text{ min/HR}) (\text{wt in kilos})}$

RATE in ml/HR = $\frac{(60 \text{ min/HR}) (\text{wt in kilos}) (\text{MG/kg/min})}{(\text{final conc in MG/ml})}$

CONC. in MG/ml = $\frac{(60 \text{ min/HR}) (\text{wt in kilos}) (\text{MG/kg/min})}{(\text{ml/HR})}$

RATE MODE = MG/kg/HR

$$\text{RATE in MG/kg/HR} = \frac{(\text{final conc in MG/ml}) (\text{ml/HR})}{(\text{wt in kilos})}$$

$$\text{RATE in ml/HR} = \frac{(\text{wt in kilos}) (\text{MG/kg/HR})}{(\text{final conc in MG/ml})}$$

$$\text{CONC. in MG/ml} = \frac{(\text{wt in kilos}) (\text{MG/kg/HR})}{(\text{ml/HR})}$$

RATE MODE = MG/HR

$$\text{RATE in MG/HR} = (\text{final conc in MG/ml}) (\text{ml/HR})$$

$$\text{RATE in ml/HR} = \frac{(\text{MG/HR})}{(\text{final conc in MG/ml})}$$

$$\text{CONC. in MG/ml} = \frac{(\text{MG/HR})}{(\text{ml/HR})}$$

APPENDIX III

DEFINITIONS

Alarm Temporary Delay Time: A custom programmed delay time of either 2 or 60 minutes that is activated when the alarm key is pressed once.

Alarm Volume: A program option in the CP mode that allows variance of the alarm auditory volume as either loud or soft.

Body Weight Mode: A level of pump operation that delivers either mcg or mg per kilo per time (e.g., minute or hour).

Bolus: A level of pump operation during which a preprogrammed amount is delivered at the fastest rate possible for the syringe size in use, by pressing both the BOLUS and PRIME keys.

Continuous Infusion Mode: A level of pump operation that allows delivery of a specific fluid volume at a specified rate. (Useful in delivery of a volume of medication at a specific constant rate.)

Custom Program Mode (CP): A level of pump operation that is limited in access by a lockout feature and generally only accessed by healthcare professionals or biomedical engineers to preprogram or customize the pump by selection of the infusion modes, the maximum infusion rate, the alarm volume, the alarm temporary delay time, volume limit, KVO rate, and alarm types.

Delivery Mode: The level of pump operation during which the infusion occurs as initiated by pressing the DELIVER key and indicated by the blinking of the green LED DELIVER Key light. All keys except the ALARM OFF/ON key and STOP/PROGRAM key are inactivated.

Delivery Time (DT): Time in hours and minutes for the dose volume to be delivered.

Dose Volume (DV): Volume (in mls) of dose to be administered (the same as volume limit in the volume/time mode).

Invalid Number: A LCD parameter that indicates what has been programmed is not consistent with other values entered. The highest possible entry that is programmable will be displayed (e.g., if a VL is entered that exceeds the syringe capacity, the display will show the highest value programmable for the syringe selected).

Light Emitting Diode (LED): A red, yellow or green light function which appear on front panel of the pump.

Liquid Crystal Display (LCD): The pump screen.

Prime: A level of pump operation that is only activated in the program mode when all another functions have been entered. Priming allows the fluid to be delivered to displace air in the tubing attached to the syringe. The actual priming volume can be verified on the prime volume counter of the LCD. The prime function also eliminates any mechanical slack whenever a newly filled syringe is loaded onto the pump.

Running Volume (RV): A recording of total volume delivered since the last volume limit reset. The volume limit minus running volume equals the volume yet to be delivered.

DEFINITIONS continued...

Standby Time: The time (in hours/minutes) on the LCD display during the standby mode that represents the time remaining before the next infusion begins.

Total Delivered: Refers to the amount of medication actually delivered during the course of an infusion (however, does not include the volume delivered in the priming mode).

Volume/Time Mode: A level of pump operation that delivers a specific dose volume over a specified delivery time (useful in delivery of a single dose over a specific time).

User Mode: A level of pump operation that is available to the user of the pump. Level of operation can be limited by custom programming or can allow the user full access to program parameters.

APPENDIX IV

CUSTOM PROGRAM MODE

The Custom Program Mode (CP) allows customization by the selection of the infusion mode (s), the bolus (yes or no), the alarm volume, the alarm temporary delay time, alarm types and syringe manufacturer. Entry into this mode is limited due to the lockout feature. This mode generally is utilized by health-care professionals and biomedical engineers to initially preprogram the pump prior to routine clinical use. Once the pump is programmed in the CP mode, go to Sections IV and V for normal operating instructions.

STEP 1: ENTERING THE CUSTOM PROGRAM (CP) MODE

STEP 1A: ENTER CP MODE

To enter the **CP Mode**, press and hold down, at the same time, the **SELECT** and **ENTER** keys then turn the pump **ON** with the power switch.

The LCD display should be blank.

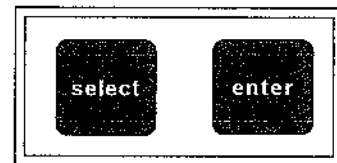

Release the **SELECT** and **ENTER** keys to visualize the **LOCK CODE** as shown.

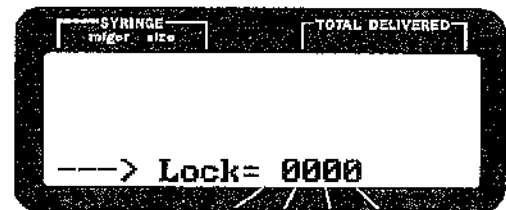

STEP 1B: ENTER LOCKOUT ACCESS CODE

Program the access code **1234** by using the appropriate **RATE SELECTION** keys.

NOTE: An inadvertent mis-entry can be corrected by pressing any two rate keys simultaneously which converts the display to zeros.

Press **ENTER** to enter the code. The pump will automatically advance to the **CP Mode** if a valid code is entered.

An erroneous code denies access to the **CP Mode**

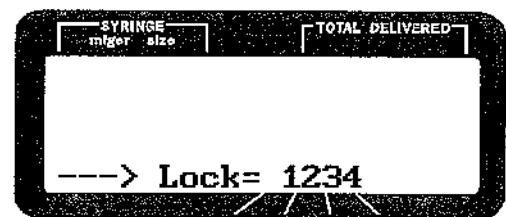

CUSTOM PROGRAM MODE continued...

STEP 2: PREPROGRAMMING DELIVERY MODES

STEP 2A: BODY-WEIGHT

The flashing LCD identifies the BODY-WEIGHT mode.

Press ENTER to access the BODY-WEIGHT mode.

OR

Press SELECT to eliminate access to the BODY-WEIGHT mode.

The LCD automatically advances to the next choice.

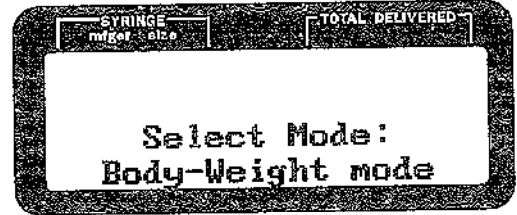

STEP 2B: MG PER HOUR

The flashing LCD identifies the MG/HR mode.

Press ENTER to access the MG/HR mode.

OR

Press SELECT to eliminate access to the MG/HR mode.

The LCD automatically advances to the next choice.

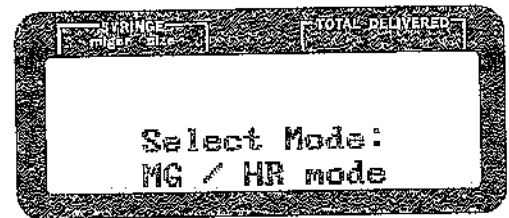

CUSTOM PROGRAM MODE continued...

STEP 2C: ML PER HOUR

The flashing LCD identifies the ml/HR mode.

Press ENTER to access the ml/HR mode.

OR

Press SELECT to eliminate access to the ml/HR mode.

The LCD automatically advances to the next choice.

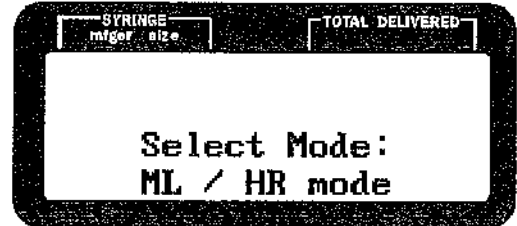

STEP 2D: VOLUME OVER TIME

The flashing LCD identifies the VOLUME/TIME mode.

Press ENTER to access the VOLUME/TIME mode.

OR

Press SELECT to eliminate access to the VOLUME/TIME mode.

The LCD automatically advances to the next choice.

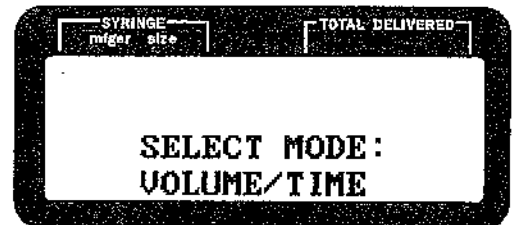

CUSTOM PROGRAM MODE continued...

NOTE: STEP 3 appears if the Body-Weight mode is the only mode ENTERED. If other modes were entered, skip to STEP 4.

STEP 3: LOCKING IN A SINGLE RATE MODE

NOTE: Locking in a single rate mode applies to the **BODY WEIGHT MODE** only. It simplifies programming by limiting the **RATE MODE** selection to one of the four available choices. Delivery in the other three **RATE MODE** choices then is not possible.

Use the **SELECT** key to change the LCD to **YES** or **NO**.

If **NO** is entered go to Step 4.

If **YES** is entered the last programmed **RATE MODE** will flash. To confirm, press **ENTER**. To change, press **SELECT**.

Press **ENTER** to enter choice.

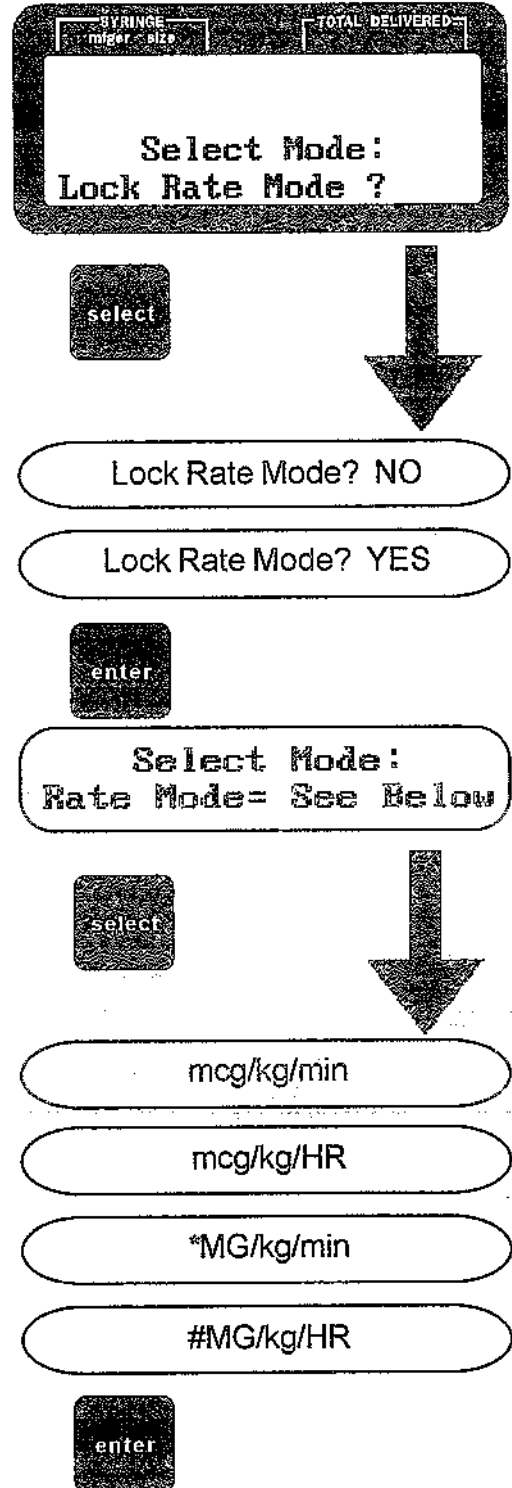

CUSTOM PROGRAM MODE continued...

STEP 4: PROGRAMMING A BOLUS AMOUNT
(only if BODY WEIGHT, MG/HR OR ML/HR was selected).

NOTE: A bolus amount cannot be programmed in VOLUME/TIME mode.

Use the **SELECT** key to change the LCD to YES or NO.

Use the **ENTER** key to program your choice.

The LCD automatically advances to the next screen.

STEP 5: ALARM OPTION

The LCD queries the ALARM option.

The **SELECT** key toggles between **SOME** and **ALL**.

Press **ENTER** to program choice.



WARNING:

Selection of the "SOME" alarm option silences the audio component for the following alarm conditions:

**STOP/PROGRAM (includes standby mode)
NEAR EMPTY
EMPTY**

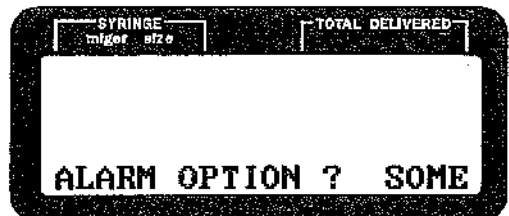
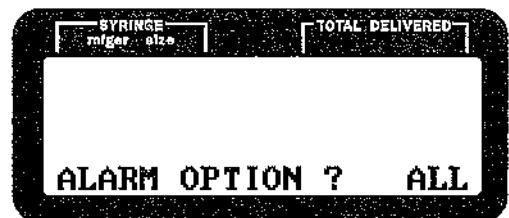
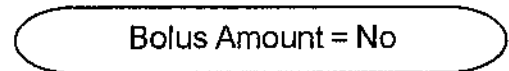
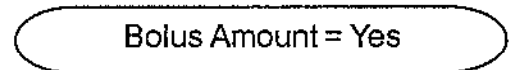
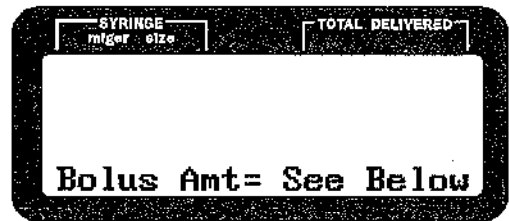

CUSTOM PROGRAM MODE continued...

STEP 6: ALARM VOLUME OPTION

The LCD will display the options for the alarm volume.

The **SELECT** key toggles between **LOUD** and **SOFT**.

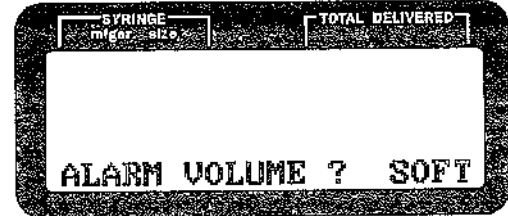
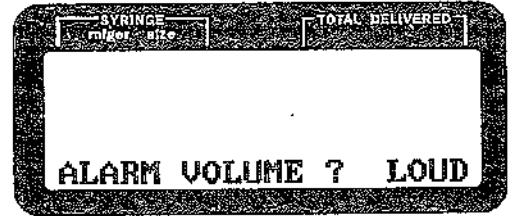

STEP 7: PROGRAMMING ALARM DELAY

The LCD queries alarm delay options.

NOTE: *The delay time is activated when the alarm off/on key is pressed.*

The **SELECT** key toggles between a 2 minute and a 1 hour delay time.

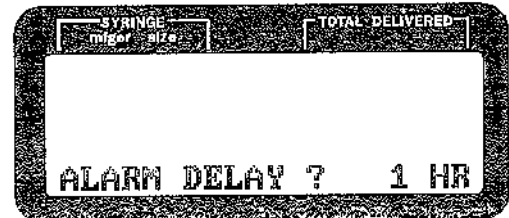
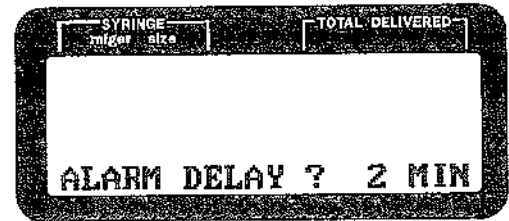

STEP 8: PROGRAMMING SYRINGE MANUFACTURER

The LCD displays the options for each syringe manufacturer according to software version which may include: **B-D**, **MONO**, **TERU**, **BBM**, **FRES**, **PERF**, **BD-G** or **ABOT**.

Press **SELECT** to eliminate access to a given manufacturer in the operation mode.

OR

ENTER the desired manufacturer(s).

NOTE: *Multiple manufacturers may be entered.*

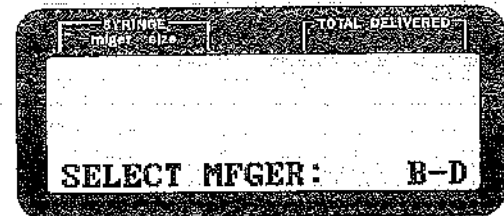

CUSTOM PROGRAM MODE continued...

STEP 10: SELECTION FOR B-D LUER LOCK SYRINGE

The **LCD** queries use of the Luer Lock B-D 1 cc syringe.

The **SELECT** key toggles between **YES** and **NO**.

Press **ENTER** to program choice.

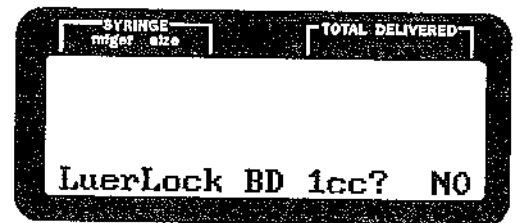
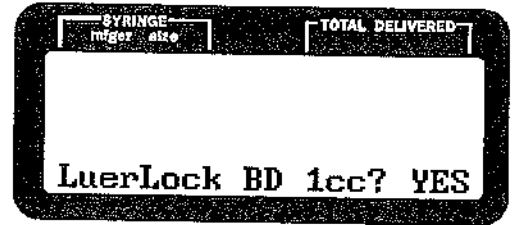

WARNING:

If **YES** is entered in the query for use of the B-D® Luer Lock 1 cc syringe, the operator must select the appropriate syringe size (i.e., 1 cc or 3 cc). The pump cannot distinguish between these syringe sizes.



VERIFY BATCH SETTINGS

The purpose of the code is to allow quick verification of the custom program settings from one pump to the next. If there is a discrepancy, it indicates some difference in custom programming.

Hold the **PRIME** key down and turn the pump on.

The custom program features in hexadecimal code will appear on the last line of the **LCD**. This code will be unique for each custom setup.

Press any key to continue programming in the operation mode.

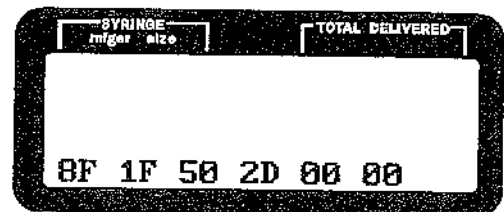

1
2
3
4
5
6
7
8
9
10
11
12
13
14
15
16
17
18
19
20
21
22
23
24
25
26
27
28
29
30
31
32
33
34
35
36
37
38
39
40
41
42
43
44
45
46
47
48
49
50
51
52
53
54
55
56
57
58
59
60
61
62
63
64
65
66
67
68
69
70
71
72
73
74
75
76
77
78
79
80
81
82
83
84
85
86
87
88
89
90
91
92
93
94
95
96
97
98
99
100
101
102
103
104
105
106
107
108
109
110
111
112
113
114
115
116
117
118
119
120
121
122
123
124
125
126
127
128
129
130
131
132
133
134
135
136
137
138
139
140
141
142
143
144
145
146
147
148
149
150
151
152
153
154
155
156
157
158
159
160
161
162
163
164
165
166
167
168
169
170
171
172
173
174
175
176
177
178
179
180
181
182
183
184
185
186
187
188
189
190
191
192
193
194
195
196
197
198
199
200
201
202
203
204
205
206
207
208
209
210
211
212
213
214
215
216
217
218
219
220
221
222
223
224
225
226
227
228
229
230
231
232
233
234
235
236
237
238
239
240
241
242
243
244
245
246
247
248
249
250
251
252
253
254
255
256
257
258
259
260
261
262
263
264
265
266
267
268
269
270
271
272
273
274
275
276
277
278
279
280
281
282
283
284
285
286
287
288
289
290
291
292
293
294
295
296
297
298
299
300
301
302
303
304
305
306
307
308
309
310
311
312
313
314
315
316
317
318
319
320
321
322
323
324
325
326
327
328
329
330
331
332
333
334
335
336
337
338
339
340
341
342
343
344
345
346
347
348
349
350
351
352
353
354
355
356
357
358
359
360
361
362
363
364
365
366
367
368
369
370
371
372
373
374
375
376
377
378
379
380
381
382
383
384
385
386
387
388
389
390
391
392
393
394
395
396
397
398
399
400
401
402
403
404
405
406
407
408
409
410
411
412
413
414
415
416
417
418
419
420
421
422
423
424
425
426
427
428
429
430
431
432
433
434
435
436
437
438
439
440
441
442
443
444
445
446
447
448
449
450
451
452
453
454
455
456
457
458
459
460
461
462
463
464
465
466
467
468
469
470
471
472
473
474
475
476
477
478
479
480
481
482
483
484
485
486
487
488
489
490
491
492
493
494
495
496
497
498
499
500
501
502
503
504
505
506
507
508
509
510
511
512
513
514
515
516
517
518
519
520
521
522
523
524
525
526
527
528
529
530
531
532
533
534
535
536
537
538
539
540
541
542
543
544
545
546
547
548
549
550
551
552
553
554
555
556
557
558
559
560
561
562
563
564
565
566
567
568
569
570
571
572
573
574
575
576
577
578
579
580
581
582
583
584
585
586
587
588
589
590
591
592
593
594
595
596
597
598
599
600
601
602
603
604
605
606
607
608
609
610
611
612
613
614
615
616
617
618
619
620
621
622
623
624
625
626
627
628
629
630
631
632
633
634
635
636
637
638
639
640
641
642
643
644
645
646
647
648
649
650
651
652
653
654
655
656
657
658
659
660
661
662
663
664
665
666
667
668
669
670
671
672
673
674
675
676
677
678
679
680
681
682
683
684
685
686
687
688
689
690
691
692
693
694
695
696
697
698
699
700
701
702
703
704
705
706
707
708
709
710
711
712
713
714
715
716
717
718
719
720
721
722
723
724
725
726
727
728
729
730
731
732
733
734
735
736
737
738
739
740
741
742
743
744
745
746
747
748
749
750
751
752
753
754
755
756
757
758
759
760
761
762
763
764
765
766
767
768
769
770
771
772
773
774
775
776
777
778
779
780
781
782
783
784
785
786
787
788
789
790
791
792
793
794
795
796
797
798
799
800
801
802
803
804
805
806
807
808
809
810
811
812
813
814
815
816
817
818
819
820
821
822
823
824
825
826
827
828
829
830
831
832
833
834
835
836
837
838
839
840
841
842
843
844
845
846
847
848
849
850
851
852
853
854
855
856
857
858
859
860
861
862
863
864
865
866
867
868
869
870
871
872
873
874
875
876
877
878
879
880
881
882
883
884
885
886
887
888
889
890
891
892
893
894
895
896
897
898
899
900
901
902
903
904
905
906
907
908
909
910
911
912
913
914
915
916
917
918
919
920
921
922
923
924
925
926
927
928
929
930
931
932
933
934
935
936
937
938
939
940
941
942
943
944
945
946
947
948
949
950
951
952
953
954
955
956
957
958
959
960
961
962
963
964
965
966
967
968
969
970
971
972
973
974
975
976
977
978
979
980
981
982
983
984
985
986
987
988
989
990
991
992
993
994
995
996
997
998
999
1000

APPENDIX V

USE OF B-D LUER LOCK SYRINGES IN THE OPERATION MODE

If B-D® Luer Lock 1 cc syringes are utilized with the Medfusion 2010 pump, the option for this selection must be made in custom programming as follows:

The **LCD** queries the use of the B-D Luer Lock 1 cc after programming options are chosen.

The **SELECT** key toggles between **YES** and **NO**.

Press **ENTER** to confirm choice.

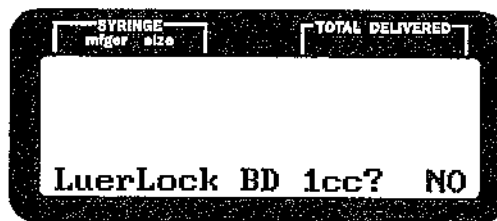
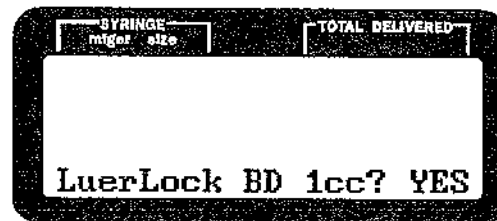

WARNING:

Always confirm that the syringe size and manufacturer stated on the LCD agree with the size and manufacturer of the syringe loaded on the pump. Failure to select the correct syringe size will result in inaccurate delivery.

