

Panasonic

Digital Color Imaging System

Operating Instructions

Model No. **KX-PS8100**

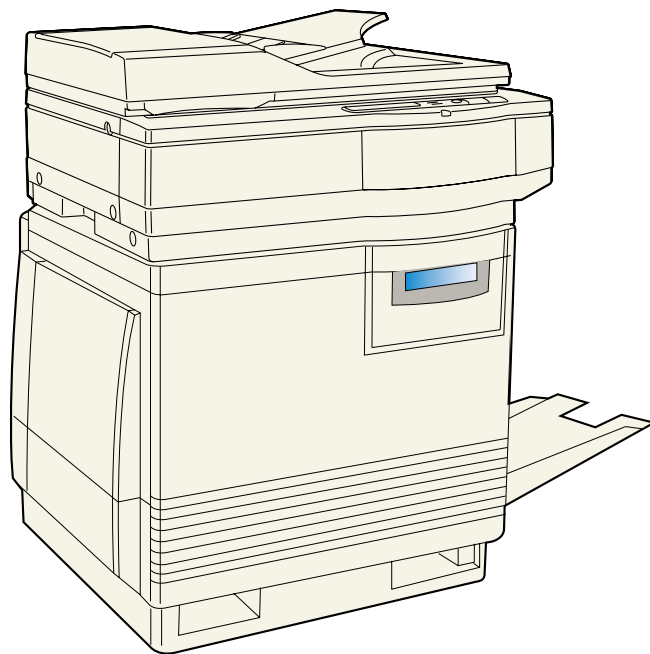

Please carefully read the Operating Instructions and the Utilities and Drivers Reference Guide before using the Digital Color Imaging System. Keep this CD-ROM in the protective case. Do not expose the CD-ROM to direct sunlight or extreme heat and do not scratch or smudge the surface of the CD-ROM.

Thank you for purchasing the Panasonic Digital Color Imaging System (DCIS) KX-PS8100.

The Panasonic Digital Color Imaging System KX-PS8100 consists of the Color Laser Printer KX-PS8101 and the Color Scanner KX-PS8102.

The serial numbers are located on the labels on the rear of the units. For your convenience, record these numbers below and keep this book along with your proof of purchase, in the event of a theft or for future reference.

MODEL NO. Printer: **KX-PS8101** Scanner: **KX-PS8102**

SERIAL NO. Printer: _____ Scanner: _____

NAME OF RESELLER _____

DATE OF PURCHASE _____

Important

- Do not duplicate bills, coins, securities and the like (with this system).
- Do not duplicate copyrighted material or the work of others except for the purpose of private use.
- Do not duplicate any kind of certificates, licenses, passports, official or private documents, and the like.



As an ENERGY STAR® Partner, Panasonic has determined that this product meets the ENERGY STAR® guidelines for energy efficiency.
(ENERGY STAR is a U.S. registered mark.)



Adobe, Acrobat, Adobe Photoshop, Adobe Illustrator, PostScript, PostScript 3, Adobe Type Manager and the PostScript 3 logo are trademarks of Adobe Systems Incorporated.



Fiery, Fiery Driven, the Fiery Driven, and ColorWise logo are trademarks owned by Electronics For Imaging and registered with the U.S. Patent and Trademark Office and in certain other foreign jurisdictions.

- Fiery WebTools, Fiery WebSpooler, Fiery WebLink, Fiery WebStatus, and VisualCal are trademarks of Electronics For Imaging, Inc.
- Apple, AppleTalk, LocalTalk, ColorSync, Macintosh, and TrueType are trademarks or registered trademarks of Apple Computer, Inc.
- IBM is a trademark of International Business Machines Corporation.
- SunOS, Solaris and Java are trademarks or registered trademarks of Sun Microsystems, Inc. in the United States and other countries.
- QuarkXpress is a trademark of Quark, Inc.
- CorelDRAW is a trademark of Corel Corporation.
- Netscape and Netscape Navigator are trademarks of Netscape Communications Corporation.
- NetWare, Novell and Internetwork Packet Exchange (IPX) are trademarks or registered trademarks of Novell, Inc.
- Times and Helvetica are trademarks of Linotype-Hell AG and/or its subsidiaries.
- PANTONE is a trademark of Pantone, Inc.
- UNIX is a trademark of X/Open Company, Ltd.
- Microsoft, MS-DOS, Windows and Windows NT are registered trademarks of Microsoft Corporation in the United States and/or other countries.
- Pentium is a registered trademark of Intel Corporation.
- Centronics is a trademark of Centronics Data Computer Corporation.
- Adaptec is a registered trademark of Adaptec, Inc.
- Avery is a registered trademark and all Avery codes are trademarks of Avery Dennison Corporation.
- All other acknowledgments are trademarks or registered trademarks of their respective holders.

Screen shots reprinted with permission from Microsoft Corporation.

Acrobat® Reader copyright ©1987-1997 Adobe Systems Incorporated. All rights reserved.

The operating instructions are subject to change without notice.

© Electronics For Imaging, Inc. 1999

© Kyushu Matsushita Electric Co., Ltd. 1999

EFI STANDARD SOFTWARE LICENSE AGREEMENT

Electronics For Imaging, Inc. grants to you a non-exclusive, non-transferable license to use the software and accompanying documentation ("Software") included with the Fiery® server you have purchased, including without limitation the PostScript® software provided by Adobe Systems Incorporated.

You may:

- a. use the Software solely for your own customary business purposes and solely with the Fiery® server;
- b. use the digitally-encoded machine-readable outline and bitmap programs ("Font Programs") provided with the Fiery® server in a special encrypted format ("Coded Font Programs") to reproduce and display designs, styles, weights, and versions of letters, numerals, characters and symbols ("Typefaces") solely for your own customary business purposes on the screen of the Fiery® server or Macintosh monitor used with the Fiery® server;
- c. use the trademarks used by Electronics For Imaging to identify the Coded Font Programs and Typefaces reproduced therefrom ("Trademarks"); and
- d. assign your rights under this Agreement to a transferee of all of your right, title and interest in and to the Fiery® server provided the transferee agrees to be bound by all of the terms and conditions of this Agreement.

You may not:

- a. make use of the Software, directly or indirectly, to print bitmap images with print resolutions of 600 dots per inch or greater, or to generate fonts or typefaces for use other than with the Fiery® server;
- b. make or have made, or permit to be made, any copies of the Software, Coded Font Programs, accompanying documentation or portions thereof, except as necessary for use with the Fiery® Server purchased by you; provided, however, that under no circumstances may you make or have made, or permit to be made, any copies of that certain portion of the Software which has been included on the Fiery® server hard disk drive. You may not copy the documentation;
- c. attempt to alter, disassemble, decrypt or reverse engineer the Software, Coded Font Programs or accompanying documentation.
- d. rent or lease the Software.

Proprietary Rights

You acknowledge that the Software, Coded Font Programs, Typefaces, Trademarks and accompanying documentation are proprietary to Electronics For Imaging and its suppliers and that title and other intellectual property rights therein remain with Electronics For Imaging and its suppliers. Except as stated above, this Agreement does not grant you any right to patents, copyrights, trade secrets, trademarks (whether registered or unregistered), or any other rights, franchises or licenses in respect of the Software, Coded Font Programs, Typefaces, Trademarks or accompanying documentation. You may not adapt or use any trademark or trade name which is likely to be similar to or confusing with that of Electronics For Imaging or any of its suppliers or take any other action which impairs or reduces the trademark rights of Electronics For Imaging or its suppliers. The trademarks may be used only to identify printed output produced by the Coded Font Programs. At the reasonable request of Electronics For Imaging, you must supply samples of any Typeface identified with a trademark. The MacApp software is proprietary to Apple Computer, Inc. and is licensed to Electronics For Imaging, Inc. for distribution only for use in combination with Fiery® server software utilities.

Confidentiality

You agree to hold the Software and Coded Font Programs in confidence, disclosing the Software and Coded Font Programs only to authorized users having a need to use the Software and Coded Font Programs as permitted by this Agreement and to take all reasonable precautions to prevent disclosure to other parties.

Remedies

Unauthorized use, copying or disclosure of the Software, Coded Font Programs, Typefaces, Trademarks or accompanying documentation will result in automatic termination of this license and will make available to Electronics For Imaging other legal remedies.

Limited Warranty And Disclaimer

Electronics For Imaging warrants that, for a period of ninety (90) days from the date of delivery to you, the Software under normal use will perform without significant errors that make it unusable. Electronics For Imaging's entire liability and your exclusive remedy under this warranty (which is subject to you returning Fiery to Electronics For Imaging or an authorized dealer) will be, at Electronics For Imaging's option, to use reasonable commercial efforts to attempt to correct or work around errors, to replace the Software with functionally equivalent software, or to refund the purchase price and terminate this Agreement. Some states do not allow limitations on duration of implied warranty, so the above limitation may not apply to you.

Except for the above express limited warranty, Electronics For Imaging makes and you receive no warranties or conditions on the Product, express, implied, or statutory, and Electronics For Imaging specifically disclaims any implied warranty or condition of merchantability or fitness for a particular purpose.

For warranty service, please contact your authorized service/support center.

EXCEPT FOR THE ABOVE EXPRESS LIMITED WARRANTY, ELECTRONICS FOR IMAGING MAKES AND YOU RECEIVE NO WARRANTIES OR CONDITIONS ON THE SOFTWARE OR CODED FONT PROGRAMS, EXPRESS, IMPLIED, STATUTORY, OR IN ANY OTHER PROVISION OF THIS AGREEMENT OR COMMUNICATION WITH YOU, AND ELECTRONICS FOR IMAGING SPECIFICALLY DISCLAIMS ANY IMPLIED WARRANTY OR CONDITION OF MERCHANTABILITY OR FITNESS FOR A PARTICULAR PURPOSE. Electronics For Imaging does not warrant that the operation of the software will be uninterrupted or error free or that the Software will meet your specific requirements.

Limitation Of Liability

IN NO EVENT WILL ELECTRONICS FOR IMAGING OR ITS SUPPLIERS BE LIABLE FOR ANY DAMAGES, INCLUDING LOSS OF DATA, LOST PROFITS, COST OF COVER OR OTHER SPECIAL, INCIDENTAL, CONSEQUENTIAL OR INDIRECT DAMAGES ARISING FROM THE USE OF THE SOFTWARE, CODED FONT PROGRAMS OR ACCOMPANYING DOCUMENTATION, HOWEVER CAUSED AND ON ANY THEORY OF LIABILITY. THIS LIMITATION WILL APPLY EVEN IF ELECTRONICS FOR IMAGING OR ANY AUTHORIZED DEALER HAS BEEN ADVISED OF THE POSSIBILITY OF SUCH DAMAGE. YOU ACKNOWLEDGE THAT THE PRICE OF FIERY REFLECTS THIS ALLOCATION OF RISK. BECAUSE SOME STATES/JURISDICTIONS DO NOT ALLOW THE EXCLUSION OR LIMITATION OF LIABILITY FOR CONSEQUENTIAL OR INCIDENTAL DAMAGES, THE ABOVE LIMITATION MAY NOT APPLY TO YOU.

Export Controls

You agree that you will not export or re-export the Software or Coded Font Programs in any form without the appropriate United States and foreign government licenses. Your failure to comply with this provision is a material breach of this Agreement.

Government Use

Use, duplication or disclosure of the Software by the United States Government is subject to restrictions as set forth in subdivision (c) (1) (ii) of the Rights in Technical Data and Computer Software clause at DFARS 252.227-7013 or in subparagraphs (c) (1) and (2) of the Commercial Computer Software—Restricted Right Clause at 48 CFR 52.227-19, as applicable.

Third Party Beneficiary

You are hereby notified that Adobe Systems Incorporated, a California corporation located at 1585 Charleston Road, Mountain View, California 94039-7900 ("Adobe") is a third-party beneficiary to this Agreement to the extent that this Agreement contains provisions which relate to your use of the Fonts, the Coded Font Programs, the Typefaces and the Trademarks licensed hereby. Such provisions are made expressly for the benefit of Adobe and are enforceable by Adobe in addition to Electronics For Imaging.

General

This Agreement will be governed by the laws of the State of California.

This Agreement is the entire agreement held between us and supersedes any other communications or advertising with respect to the Software, Coded Font Programs and accompanying documentation.

If any provision of this Agreement is held invalid, the remainder of this Agreement shall continue in full force and effect.

If you have any questions, please see Electronics For Imaging's web site at www.efi.com.

These functions are used for various tasks such as Desktop Publishing, or image editing.

End-User License Agreement

THIS IS A LEGAL AGREEMENT BETWEEN YOU AND PANASONIC. CAREFULLY READ ALL THE TERMS AND CONDITIONS OF THIS AGREEMENT PRIOR TO OPENING THE PACKET OF SOFTWARE PROGRAM. OPENING THE PACKET INDICATES YOUR ACCEPTANCE OF THESE TERMS AND CONDITIONS. If you do not agree to these terms and conditions, return the unopened packet and the other components of the Panasonic product to the place of purchase and your money will be refunded. No refunds will be given for the products that have an opened packet or missing components.

1. COPYRIGHT:

Panasonic has the right to license or has been granted to license the enclosed Software Program ("SOFTWARE"), developed and copyrighted by Kyushu Matsushita Electric Co., Ltd. or its licensor ("Licensor"). You acknowledge that you are receiving only a LIMITED LICENSE TO USE the SOFTWARE and related documentation, and that you shall obtain no title, ownership nor any other rights in or to the SOFTWARE and related documentation, all of which title and rights shall remain with Licensor and Panasonic.

2. LICENSE:

(1) You have the non-exclusive rights to use the SOFTWARE on your computer. (2) If you wish to use the SOFTWARE in your network, you may install the SOFTWARE into a network server and/or its clients and use the copies of SOFTWARE in your network. (3) You may make reasonable quantities of copies of the SOFTWARE solely for backup or archival purposes. (4) You may not rent or lease the SOFTWARE, but you may transfer your right under this License Agreement on a permanent basis, provided that you transfer this Agreement, all copies of the SOFTWARE, all related documentation and your Panasonic product, and the recipient thereof agrees to the terms of this Agreement. (5) You may not reverse engineer, decompile or disassemble the SOFTWARE, except that in European Union and European Free Trade Association, you may have the limited right to reverse engineer, decompile or disassemble the SOFTWARE solely to the extent specifically permitted by the terms and conditions of Article 6 of the European Community's Directive for the Legal Protection of Computer Programs, OJL 122/42 (17 May 1991). (6) You may not use, copy, modify, alter or transfer the SOFTWARE, any copy thereof or its related documentation, in whole or in part, except as expressly provided in this Agreement.

3. TERM:

This license is effective until terminated. You may terminate this Agreement at any time by destroying the SOFTWARE and related documentation and all copies thereof. This license will also terminate if you fail to comply with any term or condition of this Agreement. Upon such termination, you agree to destroy all copies of the SOFTWARE and related documentation.

4. LIMITED WARRANTY:

Within ninety (90) days of your receipt of the SOFTWARE, Panasonic warrants that the storage media on which the SOFTWARE are furnished is free from defect in materials and workmanship under normal use, and that it will repair or at its option replace any defective media at no charge to you, provided that such defective media is returned to Panasonic within such ninety (90) days period.

5. LIMITATION OF LIABILITY:

EXCEPT AS STATED ABOVE, NEITHER PANASONIC NOR PANASONIC'S SUPPLIER MAKES OR PASSES ON TO YOU OR OTHER THIRD PARTY, ANY WARRANTY OR REPRESENTATION INCLUDING, BUT NOT LIMITED TO, THE IMPLIED WARRANTY OF MERCHANTABILITY AND FITNESS FOR A PARTICULAR PURPOSE. WITHOUT LIMITING THE GENERALITY OF THE FOREGOING, NEITHER PANASONIC NOR PANASONIC'S SUPPLIER WARRANTS THAT THE SOFTWARE WILL BE ERROR-FREE OR THAT IT WILL MEET YOUR REQUIREMENTS. NEITHER PANASONIC NOR PANASONIC'S SUPPLIER SHALL BE LIABLE FOR ANY DAMAGE SUFFERED BY YOU INCLUDING, BUT NOT LIMITED TO, CONSEQUENTIAL, INCIDENTAL SPECIAL OR PUNITIVE DAMAGES. THE ABOVE LIMITATIONS SHALL APPLY REGARDLESS OF THE FORM OF ACTION WHETHER IN CONTRACT, TORT (INCLUDING NEGLIGENCE), STRICT PRODUCT LIABILITY OR OTHERWISE, EVEN IF SUCH PARTY HAS BEEN ADVISED OF THE POSSIBILITY OF SUCH DAMAGES.

FOR USERS IN UNITED STATES

This equipment has been tested and found to comply with the limits for a Class B digital device, pursuant to Part 15 of the FCC Rules. These limits are designed to provide reasonable protection against harmful interference in a residential installation.

This equipment generates, uses, and can radiate radio frequency energy and, if not installed and used in accordance with the instructions, may cause harmful interference to radio communications.

However, there is no guarantee that interference will not occur in a particular installation. If this equipment does cause harmful interference to radio or television reception, which can be determined by turning the equipment off and on, the user is encouraged to try to correct the interference by one or more of the following measures:

- Reorient or relocate the receiving antenna.
- Increase the separation between the equipment and receiver.
- Connect the equipment into an outlet on a circuit different from that to which the receiver is connected.
- Consult the dealer or an experienced radio/TV technician for help.

The user may find the booklet "Something About Interference" available from FCC local regional offices helpful.

FCC Warning: To assure continued FCC emission limit compliance, the user must use the recommended shielded interfacing cable when connecting to a host computer. Also, any unauthorized changes or modifications to this equipment would void the user's authority to operate this device.

Technical Support Calls

If you have read this manual and tried the troubleshooting procedures and you are still having difficulty, please contact the reseller from which the unit was purchased. You may also call the end user technical support telephone number which is operational during East Coast business hours (9:00 AM to 7:00 PM). The end user technical support number is 1-888-744-2424. This number is available within the U.S. only.

Helpful Phone Numbers

To locate your nearest sales dealer	CALL 1-800-742-8086 ask for COLOR
To order consumables	CALL 1-800-222-0584
To order operating instructions/CD's	CALL 1-800-833-9626
To locate your nearest authorized service center	CALL 1-888-744-2424
For technical support	CALL 1-888-744-2424
Automated 24-hour support via Fax back	CALL 1-800-222-0584
Electronic bulletin board	CALL 1-201-863-7845
World Wide Web Technical & Driver Support	http://www.panasonic.com/alive

Contents

EFI STANDARD SOFTWARE LICENSE AGREEMENT	4
End-User License Agreement	7
For Your Safety	15
General	15
Power source	15
Laser safety	15
Ozone release	15
Light source	16
Moving the units	16
Caution labels	17
FOR USERS IN U.K.	18

Chapter 1

Before You Start

Cautions	19
CD-ROM	21
Static electricity damage	22
Interface cable	22
Waste disposal method	22
Features	23
Scanner function	23
Printer function	24
Digital duplicator function	26
System requirements	28
With a Windows computer	28
With a Macintosh computer	29
Minimum space requirements	30
Power source	30
Unpacking	31
Scanner box	31
Printer box	32
Part names	33
Scanner	33
Printer	34
Scanner panel overview	35
LCD (Liquid Crystal Display) panel	35
Activity light	35
Buttons	36
Printer panel overview	38
LCD (Liquid Crystal Display) panel	38
Activity lights	38
Buttons	39

Chapter 2

Setup

Setting up the printer 40
 Preparing the color imaging unit 40
 Setting up the output tray 41
 Installing the toner cartridges 42
Setting up the scanner 44
 Unlocking the scanner 44
 Installing the scanner on the printer 45
 Installing the Automatic Document Feeder 47
Loading media 48
 Margins and print area 51
 Loading media in the multi-purpose tray 52
Connecting the system 57
 Digital Color Imaging System (DCIS) standard system 60
 Connecting the scanner to a computer 62
 Connecting the printer to a local port of a PC 64
 DCIS stand alone system 65
 Setting the SCSI ID number and terminator 66
Power on 68
 Printing a Test Print from the printer panel 69

Chapter 3

**Connecting
the Printer
to a Network**

Network connections 70
 Ethernet network connections 70
 Token Ring network connections 72
Setting up TCP/IP printing 73
 Setting up the printing environment 73
 UNIX server print queues 75
 Verifying the TCP/IP network connection 79
 Setting up TCP/IP clients for printing 80
 Setting up TCP/IP clients for running Fiery WebTools 80
 Printing and administering print jobs 81
Setting up IPX (Novell) printing 82
 Overview of IPX printing to the KX-PS8100 82
 Configuring the NetWare server 83
 Setting up a KX-PS8100 print queue 87
 Setting up NetWare Windows clients 90
 Using AppleTalk with Macintosh computers
 on an IPX (Novell) network 90
Setting up Windows 95 clients for SMB printing 91
Setting up Windows NT 4.0 clients for SMB printing 93

Chapter 4

**Installing
Software for
Windows**

General steps 94
Installing the software for Windows 95 95
 Installing the PostScript printer driver for Windows 95 95
 Specifying installed devices 96
 Completing the connection for Windows 95 97
 Installing the scanner driver and utilities for Windows 95 99

Chapter 4

**Installing
Software for
Windows**

Installing the software to Windows 98 103

 Installing the scanner driver, utilities and PostScript printer driver. 103

Installing the software for Windows NT 4.0 114

 Setting up PostScript printing with Windows NT 4.0 114

 Installing the PostScript printer driver for Windows NT 4.0 115

 Specifying installed devices 116

 Completing the connection for Windows NT 4.0 117

 Installing the scanner driver and utilities for Windows NT 4.0 120

Installing the software for Windows 3.1 123

 Installing the PostScript printer driver for Windows 3.1 123

 Specifying installed devices 124

 Completing the connection for Windows 3.1 125

 Installing the scanner driver and utilities for Windows 3.1 128

Installing additional software for Windows users 130

 PostScript and TrueType fonts. 130

 ATM (Windows 95 and Windows 3.1) 130

 Color reference pages 132

Installing the bundled software 133

Removing the KX-PS8100 software 134

Chapter 5

**Installing
Software for
Macintosh**

General steps for installing Macintosh software 136

Installing Macintosh printing software 137

 Installing the Adobe PostScript printer driver. 137

 Setting up the KX-PS8100 in the Chooser. 138

 Installing the KX-PS8100 ColorSync profile. 139

Installing the scanner driver. 141

 Using the TWAIN scanner driver 142

 Using the Photoshop Plug-in scanner driver 143

Installing additional software for Macintosh users 144

 Adobe Type Manager. 144

 PostScript and TrueType fonts. 144

Chapter 6

**Setup from
the Printer
Panel and
WebSetup**

Initial Setup from the printer panel 145

 Power Saver. 146

 Parallel Port Setup 146

 Network Port Setup 146

 Network Protocol Setup 148

 Language Setup 150

 Reset Queues 150

 Hard Disk 150

Chapter 6
**Setup from
the Printer
Panel and
WebSetup**

Completing setup from Fiery WebSetup 151
 Setting up Fiery WebTools 151
 Accessing Fiery WebSetup 154
 System Setup 156
 Network Setup 158
 Printer Setup 168
 Saving your settings and exiting Fiery WebSetup 169

Chapter 7
**Color
Calibration**

Bias adjustment 171
VisualCal, 30% match calibration 176
 Calibrating the printer using VisualCal 177
 Resetting the VisualCal calibration 182
Color adjustment 183
 Resetting the color adjustment 185

Chapter 8
**Basic
Operations**

Before operation 186
 Acceptable documents 186
 Unacceptable documents 186
 Placing documents 187
Scanning documents 188
 Printing a scanned document 192
 Saving a scanned document 193
Duplicating documents 194
 Using the Digital Duplicator Utility 194
 Using the scanner panel 196
The printer panel functions and menus 197
 Printer's status messages 197
 Printer's error messages 198
 Printer's main menus 198
 Printing pages from the printer panel 202
The scanner panel functions and menus 204
 Scanner's status messages 204
 Scanner's error messages 204
 Scanner's main menus 204

Chapter 9
**Care and
Maintenance**

Cleaning 209
 Scanner 209
 Printer 210
Life of components 213
User replaceable components 213
Displaying the life of supplies and coverage of toner 216
 Maintenance 216
 Image area 217

Chapter 9

Care and Maintenance

Clearing media jams	218
Scanner	218
Printer	220
Troubleshooting	234
Scanner	234
Printer	236
LCD panel messages	246
Scanner LCD panel	246
Printer LCD panel	248
LCD panel service calls	254
Status display program for Windows	255
Scanner Status window	256
Printer Status window	258
Repacking	260
Packing the scanner	261
Packing the printer	263

Chapter 10

Options

Upgrade options	272
Removing and replacing the printer controller board	273
Installing a hard disk drive	275
Kit contents	275
Initializing the hard disk	278
Installing additional memory	278
Kit contents	278
Installing SDRAM DIMMs	279
Installing network cards	281
Kit contents	281

Appendix

Specifications	284
Scanner	284
Printer	286
Duplicate	288
Software	289
Media	290
Bidirectional parallel interface	296
SCSI interface	298
Controller	299

Index	300
--------------------	------------

For Your Safety

General

Warning

- To prevent fire or shock hazard, do not expose this product to rain or any type of moisture.

Cautions

- Do not open covers and do not attempt to repair the unit yourself. Refer servicing to qualified personnel.
- Avoid contact with the rotating rollers when the ADF top cover is open.

Power source

Warning

- The power source voltage of this unit is listed on the nameplate. Only plug the unit into an outlet with the proper voltage.
- When you operate this equipment, the outlet should be near the equipment and accessible.
- To ensure safe operation the AC cord supplied must be inserted into standard three-prong AC outlet which is effectively grounded (earthed) through the normal wiring.
- The fact that the equipment operates satisfactorily does not imply that the power point is grounded (earthed) and that the installation is completely safe. For your safety, if in any doubt about the effective grounding (earthing) of the power point, consult a qualified electrician.
- If the plug cannot be inserted into the AC outlet, contact a licensed electrician to replace the outlet with a properly grounded (earthed) one. Do not defeat the purpose of the grounding (earthing) plug (ex. do not use a conversion plug).

Laser safety

Caution

- This printer utilizes a laser. Use of controls or adjustments or performance of procedures other than those specified herein may result in hazardous radiation exposure.

Ozone release

Warning

- Make sure that the printer is installed in a well ventilated room so as not to increase density of ozone in the air. Since ozone is heavier than air, it is recommended that air at floor level be ventilated.

Light source

- Do not look directly at the light source lamps of the scanner when scanning as this may be harmful to your eyes.

Moving the units

The scanner weighs approximately 22.5 kg {49.5 lbs.} and the printer weighs approximately 49.5 kg {108.9 lbs.}. They must be handled by two people. Turn the power off and remove the power cords when handling the units.

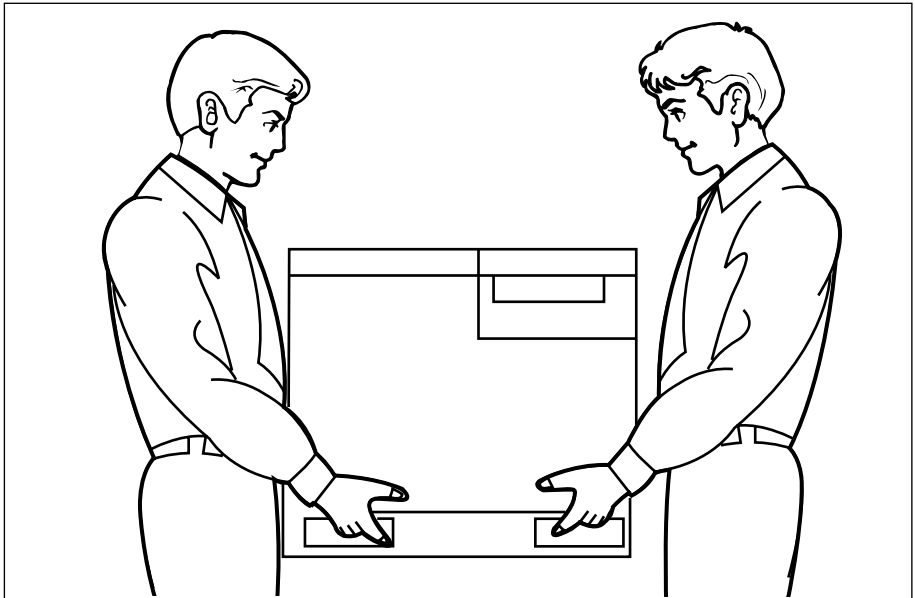
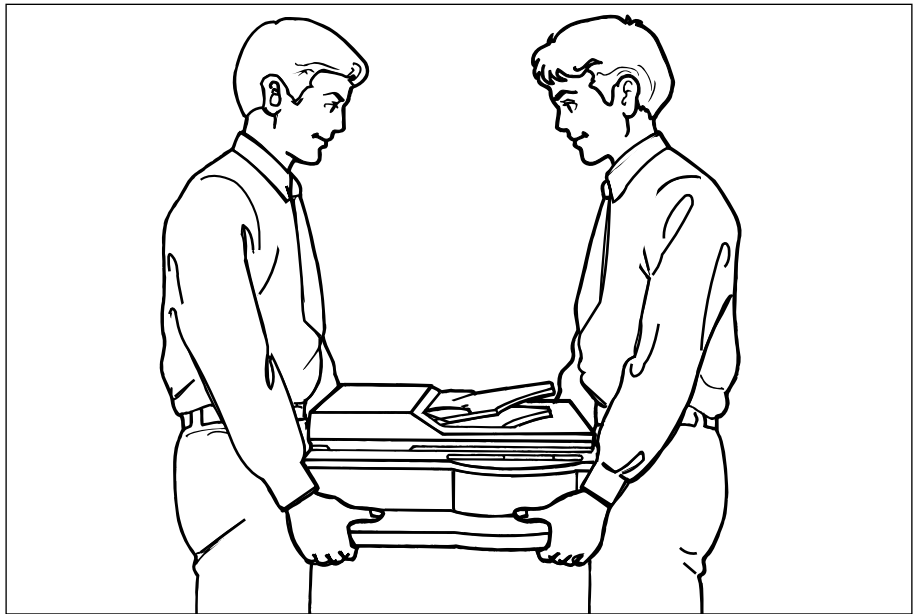

Caution labels

<p>DANGER: Invisible laser radiation when open and interlock defeated. AVOID DIRECT EXPOSURE TO BEAM.</p>	<p>CAUTION: Invisible laser radiation when open and interlocks defeated. AVOID EXPOSURE TO BEAM.</p>	<p>VORSICHT: Unsichtbare Laserstrahlung, wenn Abdeckung geöffnet und Sicherheitsverriegelung überbrückt. NICHT DEM STRAHL AUSSETZEN.</p>	<p>ATTENTION: Rayonnement laser invisible dangereux en cas d'ouverture et lorsque la sécurité est neutralisée. EXPOSITION DANGEREUSE AU FAISCEAU.</p>		
<p>PELIGRO: Cuando se abre y se invalida el bloqueo, se producen radiaciones invisibles de láser. EVITESE LA EXPOSICIÓN A TALES RAYOS.</p>	<p>VARNING: Osynlig laserstrålning när denna del är öppnad och spärren är urkopplade. STRÅLEN ÄR FARLIG.</p>	<p>VARO!: Näkymätöntä avattaessa ja suojaletyhtis ohitettaessa olet alttiina lasersäteilylle. ALÄ KATSO SÄTEESEEN.</p>	<p>VARNING: Osynlig laserstrålning när denna del är öppnad och spärren är urkopplad. BETRAKTA EJ STRÅLEN.</p>		<p>ADVARSEL: Usynlig laserstrålning ved åbning når sikkerhedsafbrydere er ude af funktion. UNDGÅ UDSÆTTELSE FOR STRÅLING.</p>

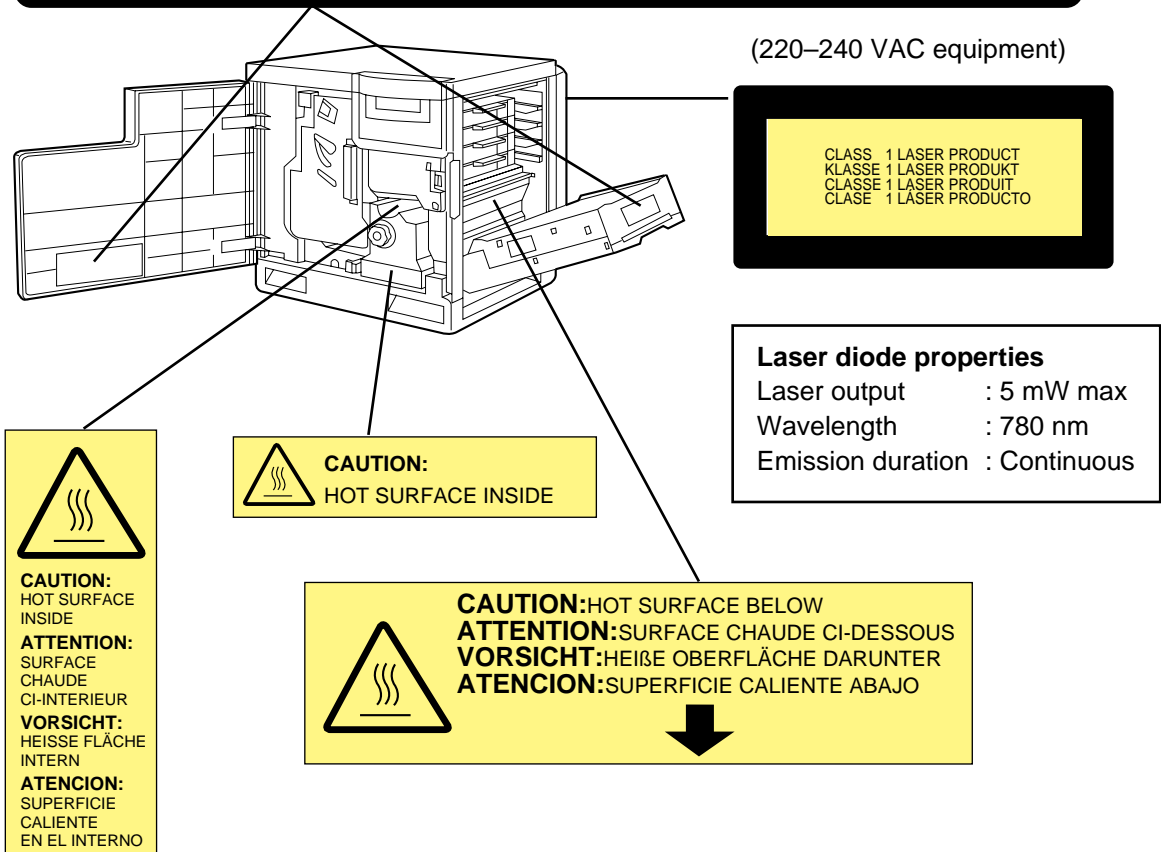



FOR USERS IN U.K.

IMPORTANT:

FOR YOUR SAFETY PLEASE READ THE FOLLOWING TEXT CAREFULLY

Both the printer and scanner are supplied with a moulded three pin mains plug each for your safety and convenience.

A 13 amp fuse is fitted in this plug. Should the fuse need to be replaced please ensure that the replacement fuse has a rating of 13 amps and that it is approved by ASTA or BSI to BS 1362.

Check for the ASTA mark  or the BSI mark  on the body of the fuse.

If the plug contains a removable fuse cover you must ensure that it is refitted when the fuse is replaced. If you lose the fuse cover the plug must not be used until a replacement cover is obtained. A replacement fuse cover can be purchased from your local Panasonic Dealer.

IF THE FITTED MOULDED PLUG IS UNSUITABLE FOR THE SOCKET OUTLET IN YOUR HOME THEN THE FUSE SHOULD BE REMOVED AND THE PLUG CUT OFF AND DISPOSED OF SAFELY. THERE IS A DANGER OF SEVERE ELECTRICAL SHOCK IF THE CUT OFF PLUG IS INSERTED INTO ANY 13 AMP SOCKET.

If a new plug is to be fitted please observe the wiring code as shown below. If in any doubt please consult a qualified electrician.

WARNING: THIS APPLIANCE MUST BE EARTHED.

IMPORTANT: The wires in this mains lead are coloured in accordance with the following code.

Green-and-Yellow: Earth Blue: Neutral Brown: Live

As the colours of the wire in the mains lead of this appliance may not correspond with the coloured markings identifying the terminals in your plug, proceed as follows.

The wire which is coloured GREEN-AND-YELLOW must be connected to the terminal in the plug which is marked with the letter E or by the Earth symbol  or coloured GREEN or GREEN-AND-YELLOW.

The wire which is coloured BLUE must be connected to the terminal in the plug which is marked with the letter N or coloured BLACK.

The wire which is coloured BROWN must be connected to the terminal in the plug which is marked with the letter L or coloured RED.

How to replace the fuse: Open the fuse compartment with a screwdriver and replace the fuse.

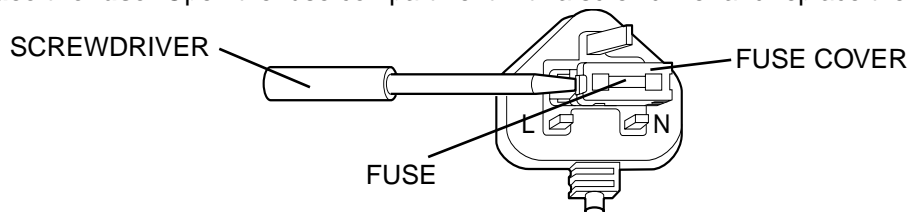

FOR USERS IN AUSTRALIA

This mark shows that the product complies with AS/NZS 3548.

Chapter 1 *Before You Start*

Before you set up your new system, please read the following information.

Cautions

To avoid problems, do not use the equipment under the following conditions:



- Direct exposure to sunlight
 - Extremely high or low temperature [temperature range: 10°C to 32.5°C (50°F to 90.5°F)]
 - Extremely high or low humidity (humidity range: 20% to 80% RH)
 - Condensation due to rapid change of temperature
-

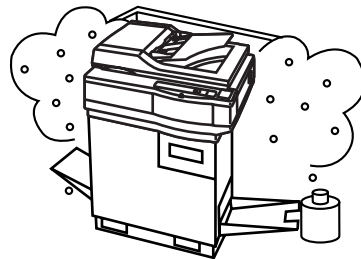

- Areas of poor ventilation
 - Areas of high dust or chemical fume concentration (solvent etc.)
-

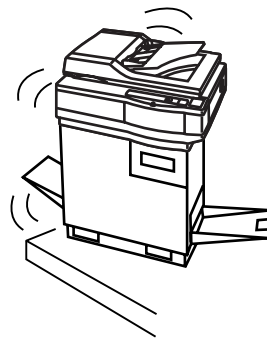
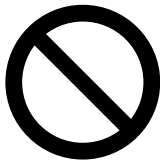

- Unstable or unlevel surfaces
-

Before You Start

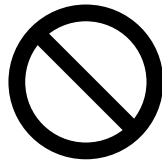

- Directly in front of air conditioning vents
-

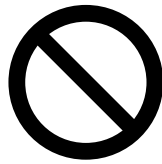

- Liquids near the equipment
 - Liquid spills can cause severe damage.
-



- Too much media/document which exceeds the limit mark () on the guide of the tray.
-

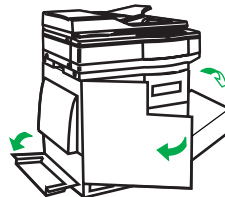
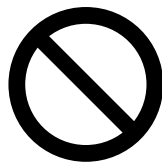

- Front/right/left doors opened while the printer is operating; it may cause a media jam.
-

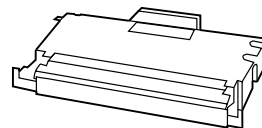

Not genuine toner

- Any toner other than genuine Panasonic toner. It may damage the printer.
-

CD-ROM

To prevent accidental damage to the CD-ROMs:

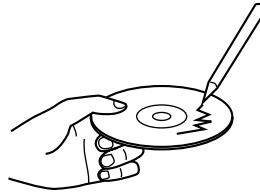

- Do not touch or write on the surface of the disc.
-

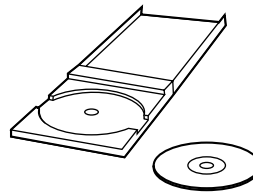
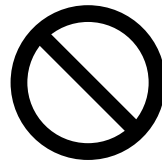

- Do not leave the disc out of the protective case.
-

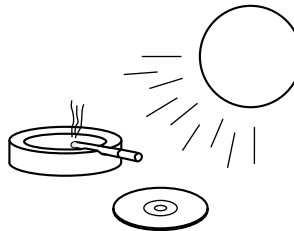
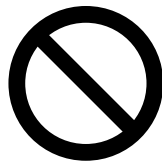

- Do not leave the disc in direct sunlight or near heat sources.
-

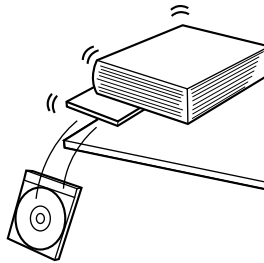

- Do not place heavy objects on the disc case or drop the case.
-

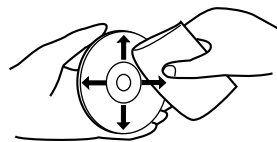

- To clean the disc, hold the disc by its edges and wipe it from the center to the edges with a dry, soft cloth.
-

Before You Start

Static electricity damage

To prevent static electricity damage to any of the following components, touch a grounded metal surface, such as the printer's bare metal frame prior to touching the component.

- The interface connectors—SCSI, parallel, and optional network
- ADF interface connector
- Electrical components, connectors inside the printer, any components on the optional board (hard disk drive, SDRAM DIMMs, Ethernet network card, or Token Ring network card)
- The connector pins on the optional 2nd cassette feeder for the printer

Interface cable

Always use a shielded cable. Use of an unshielded cable can result in radio interference with data.

Waste disposal method

Waste material may be dumped or incinerated under conditions which meet national and local environmental regulations.

Features

The KX-PS8100 system is a high quality system that provides fast color image processing functions, including color scanning, color printing, and color duplicating.

The KX-PS8100 system is comprised of two components:

- **Color laser printer (KX-PS8101)**
- **Color scanner (KX-PS8102)**

The KX-PS8100 system offers you the following functions:

- **Scanning**
- **Printing**
- **Digital Duplicating** (using Digital Duplicator Utility or the scanner panel)

These functions are available depending on the system.

	Windows	Macintosh
Scanning	Yes	Yes
Printing	Yes	Yes* ¹
Digital Duplicating	Yes	Yes* ²

*¹ Only when using Network port.

*² Digital duplicating using Digital Duplicator Utility is not available.

NOTES:

- Positioning the scanner on top of the printer will conserve space.
- Each component can be used individually.
- Additional SDRAM DIMM upgrades improve performance.

Scanner function

■ High quality

- **Resolution**—Optical 600 dpi (dots per inch)
 - Flatbed: 30 to 9600 dpi is software selectable.
 - ADF: 60 to 2400 dpi is software selectable.
- **Color**
 - Full-color mode: Maximum 16.7 million colors
 - Monochrome mode: Maximum 256 grayscale levels

■ Networking and client capabilities

- Supports AppleTalk (EtherTalk), TCP/IP, and IPX (Novell) protocols simultaneously by installing optional Ethernet Card
- Supports thicknet, twisted pair, and thinnet (via transceiver) cabling
- Ethernet support by installing optional Ethernet Card
- Token Ring support by installing optional Token Ring Card
- SMB (Microsoft®)
- IEEE 1284 compliant, Mini-Centronics type-C parallel connection based on the IEEE P1284-C standard

NOTE:

- An ECP compatible parallel port is recommended for Windows® 95*¹. To turn on the ECP mode, use the computer's BIOS setup. Refer to the computer's documentation for details.

*¹ Microsoft® Windows® 95 operating system (hereafter Windows 95)

■ Color capabilities

ColorWise™ CRDs (color rendering dictionaries) take full advantage of the colors available on your printer. PostScript 3 RGB files are converted to the printer's CMYK color space during processing—optimizing them for rendering and printing. CRDs available with the PostScript driver include:

- Photographic
- Presentation
- Transparency

Using the PostScript driver an image's RGB data can be also converted to the color space and gamut of the printer using RGB source profiles. Profiles available include:

- EFIRGB
- sRGB (PC)
- Apple Standard

In addition, CMYK simulation settings can be used to simulate popular offset printing press standards. Simulation settings include:

- SWOP
- Euroscale
- DIC

■ Color management

ColorWise VisualCal™ allows experienced users to calibrate the printer for excellent color output—eliminating out-of-calibration color most printers experience over time.

ColorWise Color Adjustment provides controls for globally modifying toner density and brightness.

ColorWise Business Color specifies the application of toner using a diffusion dither pattern, which is ideal for color fills and blends commonly found in charts and graphs used in business applications.

■ Fiery WebTools

Fiery WebTools are utilities that enable users to manage the printer from the Internet or your company's intranet:

- Fiery WebDownloader
- Status
- Fiery WebSetup
- Fiery WebLink
- Fiery WebSpooler

For additional information on printer specifications, [see page 286](#).

Digital duplicator function

■ High quality

- **Resolution**—Resolution is set according to the selected mode.
Standard mode: 600 x 300 dpi (300 x 300 dpi for B/W Text)
Fine mode: 600 x 1200 dpi

■ Image conversion function

Adjusts individual toner densities.

Scanned colors R (red), G (green), B (blue) are converted to printed colors C (cyan), M (magenta), Y (yellow), K (black) automatically.

High speed

- **Continuous full-color printing on letter size paper using ADF (Automatic Document Feeder)**

	4 Color (CMYK)* ¹	3 Color (CMY)* ^{2*3}
Standard mode	Maximum 3.5 ppm (pages per minute)	Maximum 4.7 ppm
Fine mode	Maximum 1.8 ppm	Maximum 2.4 ppm

*¹ “Text and Graphics” when using the scanner panel

*² only when using plain paper

*³ “Photo” when using the scanner panel

Easy operation

- **Front Key Panel**—Easily duplicate documents.

Digital duplicator utility

Includes various editing operations, such as color adjustment, enlargement/reduction, drawing text strings, saving the layout image, mirroring, and area duplicate.

For additional information on digital duplicator specifications, [see page 288](#).

The icons in this document indicate:



: Features and functionality which require an optional hard disk drive.
See “Installing a hard disk drive” on page 275.



: Features and functionality which require a minimum of 32 MB of SDRAM.
See “Installing additional memory” on page 278.



: Features and functionality available to printers operating in a networked environment.
See “Installing network cards” on page 281

System requirements

You can use the KX-PS8100 system in a networked environment and print from a PC compatible computer running Windows or from a Macintosh computer.

To operate the KX-PS8100 system effectively, see the following.

With a Windows computer

CPU:	An IBM PC or compatible computer with Pentium or higher (133 MHz or faster CPU is recommended.)
Operating system* ¹ :	Windows® 3.1* ² , Windows 95, Windows® 98* ³ or Windows NT® 4.0* ⁴ * ⁵ (Intel only)
RAM:	16 MB or more (More than 32 MB is recommended.)
Free disk space:	100 MB or more
Virtual memory:	16 MB or more (More than 32 MB is recommended.) for Windows 3.1 or Windows 95 50 MB or more* ⁶ (More than 100 MB is recommended.) for Windows NT 4.0
Display:	Video card that can display more than 800 x 600 dpi 256 colors (A video card that can display more than 32,000 colors is recommended.)
Drive:	CD-ROM drive
Mouse:	A mouse that is supported by Windows

*¹ See page 289 to confirm which software is applied to your operating system

*² Microsoft® Windows® operating system Version 3.1 (hereafter Windows 3.1)

*³ Microsoft® Windows® 98 operating system (hereafter Windows 98)

*⁴ Microsoft® Windows NT® Workstation operating system, and Microsoft® Windows NT® Server network operating system Version 4.0 (hereafter Windows NT 4.0)

*⁵ Service Pack 3 or later version is required.

*⁶ In the Virtual Memory window, change this setting in the Initial Size box.

Interface:	SCSI interface requirements SCSI cable: SCSI-2 (FAST SCSI) compatible (page 298) SCSI-2 board: ASPI Manager compatible SCSI-2 board (Adaptec AHA-2940 is recommended.) ASPI manager: ASPI Manager is required. (See the SCSI-2 board manual.) Parallel interface requirements ECP mode: Based on the IEEE P1284-C standard (An ECP compatible parallel port is recommended for Windows 95.) To turn on the ECP mode, use the computer's BIOS setup. Refer to the computer's documentation for details.
Cable:	Appropriate interface cables for your network or printer connection

***With a Macintosh
computer***

To operate the KX-PS8100 system effectively, see the following.

CPU:	More than PowerPC (faster CPU is recommended.)
Operating system:	Apple system software version 7.5.x, 7.6.x or 8.0 (Printer Driver) Apple system software version 7.5.x, 7.6.x, 8.0, 8.1 or 8.5 (Scanner Driver)
Interface:	Ethernet Card (Printing): The KX-PS8100 Ethernet card does not enable printing directly from the Macintosh computer. Printing from a Macintosh can only be performed if the KX-PS8100 and Macintosh are connected to a network. SCSI cable (Scanning): SCSI-2 (FAST SCSI) compatible (page 298)
Cable:	Appropriate interface cables for your network or printer connection

To use ColorSync Color Matching of the scanner driver, ColorSync Manager
Version 2.0 or later is required.

Photoshop Plug-in is supported on Adobe Photoshop 3.0 or later.

Minimum space requirements

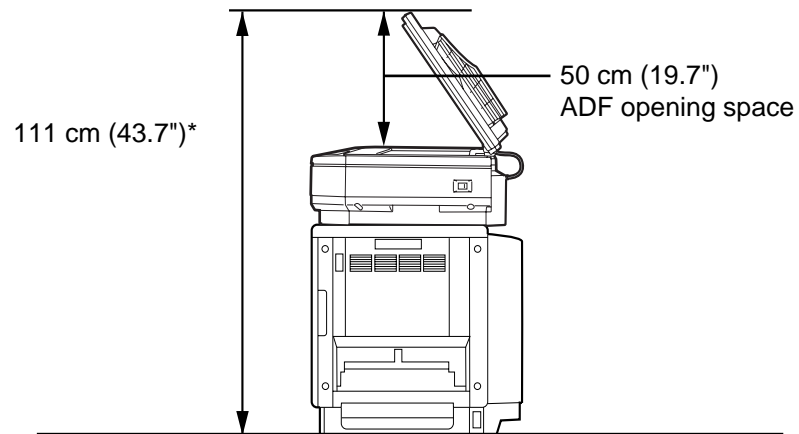

* 132.5 cm (52.2") with optional 2nd cassette feeder

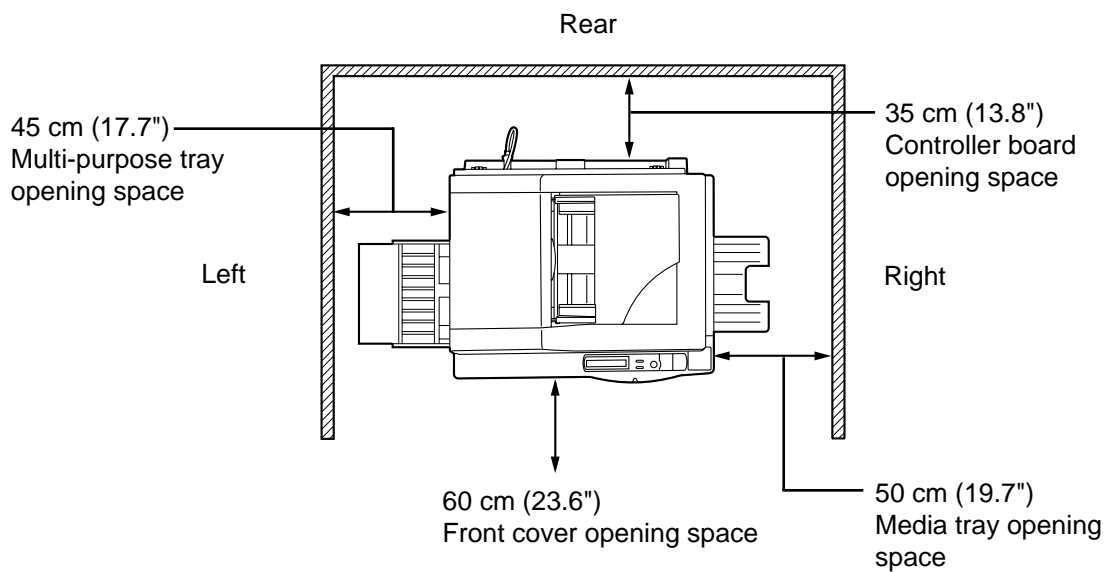

Power source

- The voltage level of the power source must not vary more than $\pm 10\%$ from the voltage level marked on the nameplate (located on the back of the units).
- Do not use an extension cord.
- Do not use a line conditioner, transient suppressor or surge protector as it may cause a machine error.

Unpacking

Make sure that all of the items shown below were provided and have not been damaged. Report damage or shortages to the reseller from which the units were purchased. **Page 2** includes an area for recording important information such as the name of reseller, serial numbers, and date of purchase.

NOTE:

- Save the original cartons and packing materials for future shipping and transporting of the units. They have been specifically designed to protect the equipment during shipment.

Scanner box

1. Scanner
2. ADF (Automatic Document Feeder)
3. Power cord

1

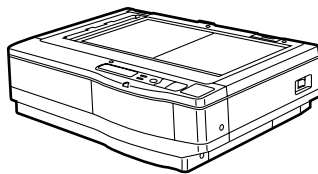

2

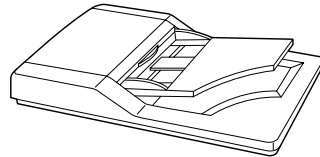

3



Before You Start

Printer box

1. Printer (color imaging unit, fuser unit and media tray are included.)
2. Toner cartridges (black, cyan, magenta, and yellow)
3. Power cord
4. SCSI cable (for connection between the scanner and the printer)
5. Guide pins (2)
6. KX-PS8100 CD-ROM Disc1
(includes Printer driver & Utility)
7. KX-PS8100 CD-ROM Disc2
(includes Scanner driver & Utility, Operating Manuals and Acrobat Reader)
8. CorelDRAW Select Edition (CD-ROM Disc1, 2)
9. Color Calibration Card
10. Setup Manual (The manuals in other languages may also be included.)
11. ID maintenance administrator password (sheet)

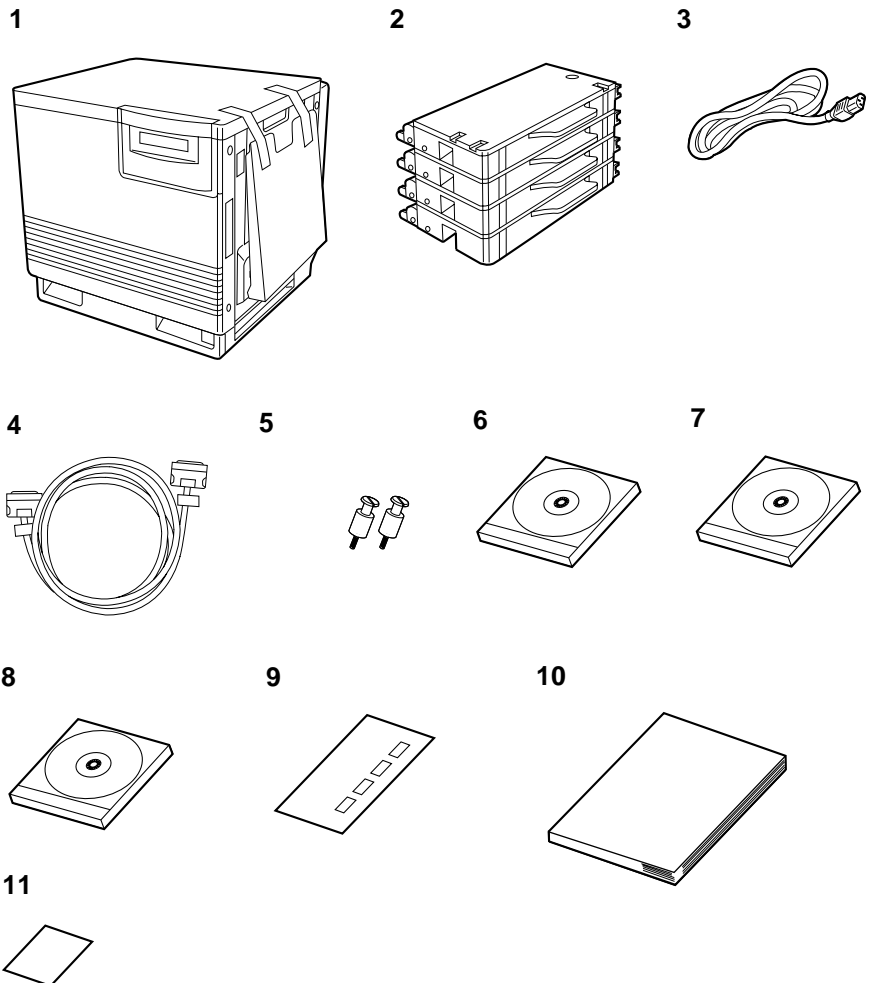

Part names

Scanner

■ Front side view

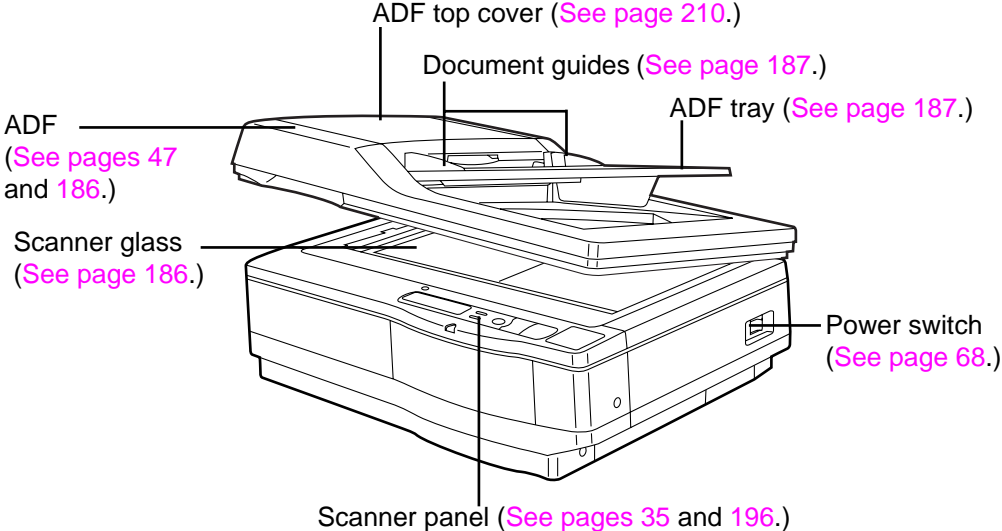

■ Rear side view

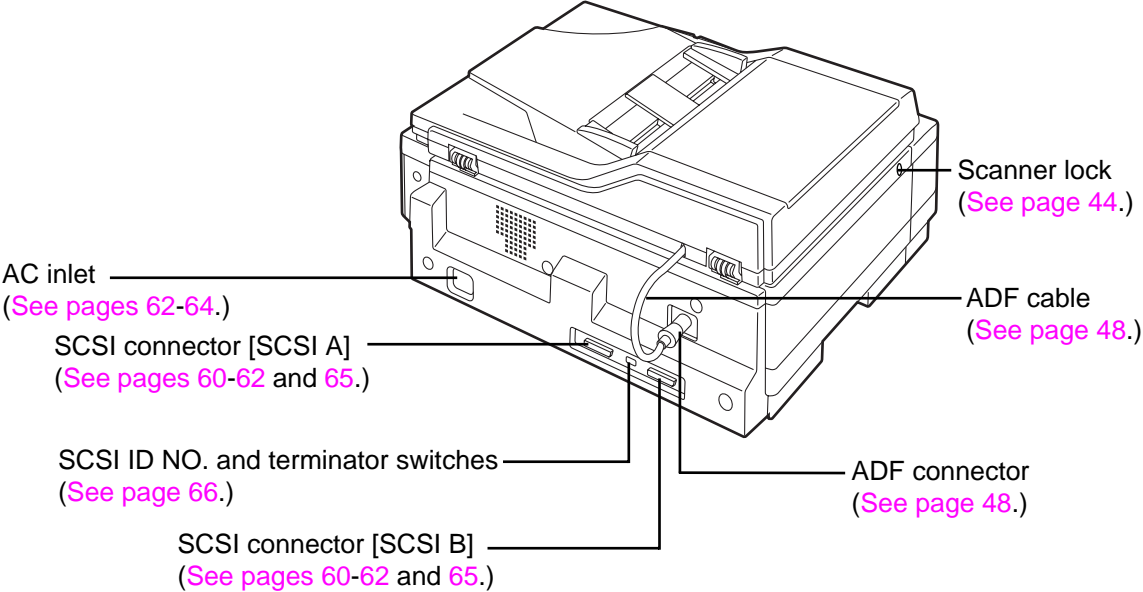

Printer

■ Front side view

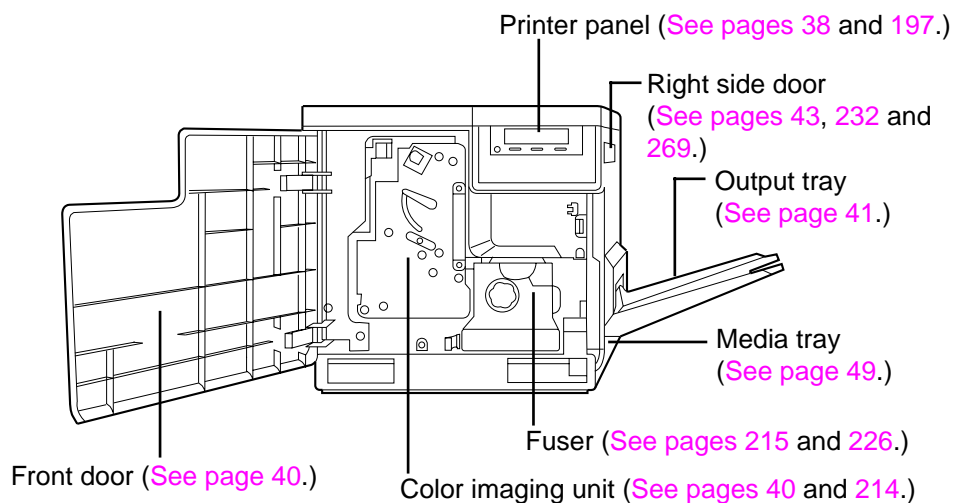

■ Rear side view

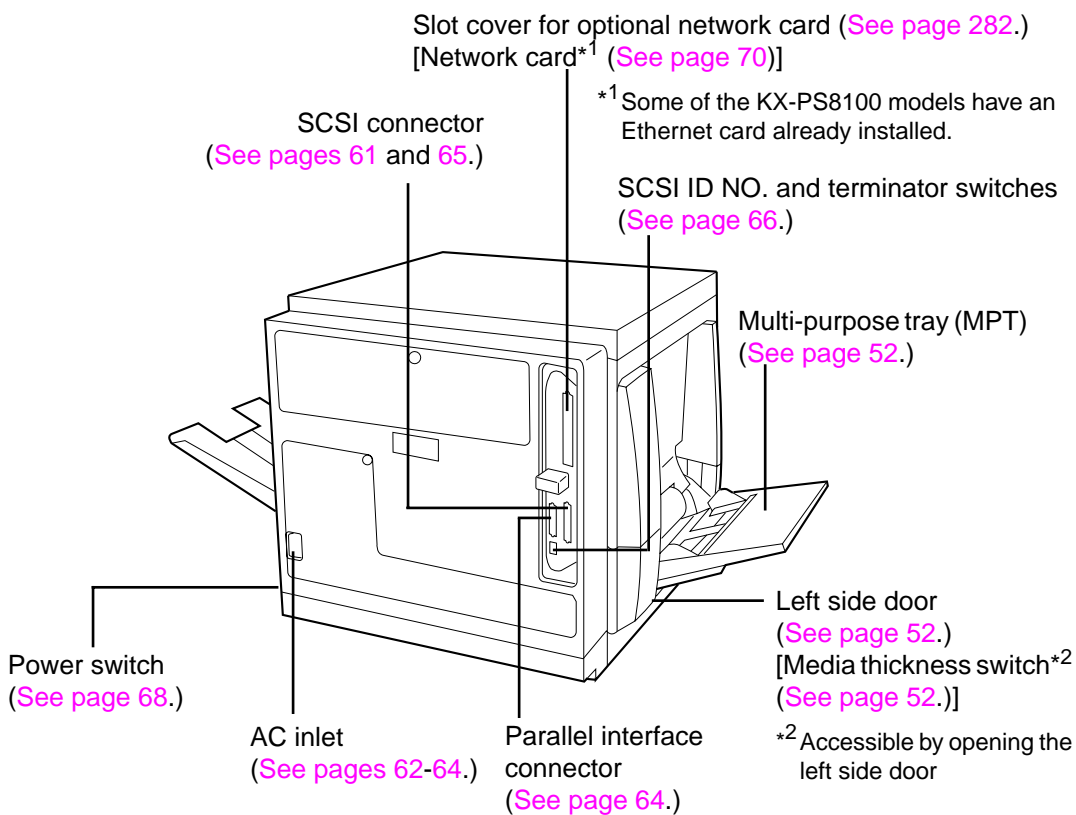

Scanner panel overview

This section describes the functions of the scanner panel, illustrated below:

LCD (Liquid Crystal Display) panel

The scanner LCD has two 20-character lines to display the scanner's or duplicator's status/error messages or the duplicator's menu settings. When the duplicator is ready, "Ready" with duplicate settings such as number of copy, density setting is displayed.

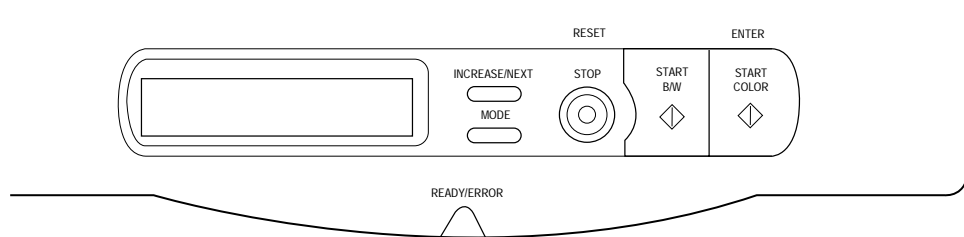

Activity light

The activity light indicates the status of the scanner. It has the following meanings:

This light	Indicates
<p>READY/ERROR</p>	<p>READY/ERROR indicator—</p> <ul style="list-style-type: none"> The READY indicator (green) ON: the scanner is ready for operation. Blinking: the scanner is initializing or scanning. The ERROR indicator (orange) ON: an internal error (Call for Service Error) has occurred. Blinking: user correctable error such as ADF jam has occurred.

Status	READY Indicator (green)	ERROR Indicator (orange)
Diagnosing.../Initializing...	Blinking*1	OFF
Ready	ON	OFF
Scanning	Blinking*2	OFF
Scanning (for duplicate)	Blinking*3	OFF
Printing (for duplicate)	Blinking*1	OFF
User Correctable Error	OFF	Blinking
Call for Service Error	OFF	ON



*1 Blinking with an interval of approximately 1.7 seconds

*2 Blinking with an interval of approximately 0.9 second



*3 Blinking with an interval of approximately 0.7 second

Buttons

The scanner panel's buttons have the following meanings:

This button	Indicates
<p style="text-align: center;">INCREASE/NEXT </p>	<p>INCREASE/NEXT button—</p> <ul style="list-style-type: none"> • When the scanner is ready, pressing this button increases the number of duplicates by 1. You can set the number of duplicates from 1 to 99. Pressing this button for more than 2 seconds automatically increases the number of duplicates by 1. Pressing this button for more than 8 seconds increases the number of duplicates by 10. • When the scanner is ready, pressing MODE + INCREASE/NEXT decreases the number of duplicates by 1. You can set the number of duplicates from 1 to 99. Pressing MODE + INCREASE/NEXT for more than 2 seconds automatically decreases the number of duplicates by 1. Pressing MODE + INCREASE/NEXT for more than 8 seconds automatically decreases the number of duplicates by 10. • In the Menu mode, pressing this button displays the next selection.
<p style="text-align: center;">MODE </p>	<p>MODE button—</p> <ul style="list-style-type: none"> • When the scanner is ready, pressing this button enters the Menu mode. • In the Menu mode, pressing this button displays the next menu. • Pressing MODE + START COLOR, or MODE + START B/W allows you to select a print type and starts the duplicating process. • Pressing MODE + INCREASE/NEXT allows you to decrease the number of duplicates.

(Continued)

This button	Indicates
<p style="text-align: center;">STOP</p> 	<p>STOP/RESET button—</p> <p>Pressing this button:</p> <ul style="list-style-type: none"> • Exits the Menu mode. • Stops the duplicating process. (However, it does not stop immediately because of data processing.) • (When the number of duplicates is not 1) Sets the number of duplicates as 1. • (When the number of duplicates is 1) Resets the scanner panel settings to the Menu Default setting (when “Ready” is displayed). • (When error messages such as “Memory Overflow” is displayed) Recover from an error situation.
<p style="text-align: center;">START B/W</p> 	<p>START B/W button—</p> <ul style="list-style-type: none"> • When a document is placed in the ADF tray or on the scanner glass, pressing this button makes a black and white duplicate, regardless of the color of the document.
<p style="text-align: center;">START COLOR</p> 	<p>START COLOR/ENTER button—</p> <ul style="list-style-type: none"> • When the scanner is ready and a document is placed in the ADF tray or on the scanner glass, pressing this button makes a duplicate of the document. If the original is a color document, a color duplicate is created. • In the Menu mode, after changing a selection, pressing this button activates a selection. A “✕” appears to the left of the selection.

Printer panel overview

This section describes the functions of the printer panel, illustrated below:

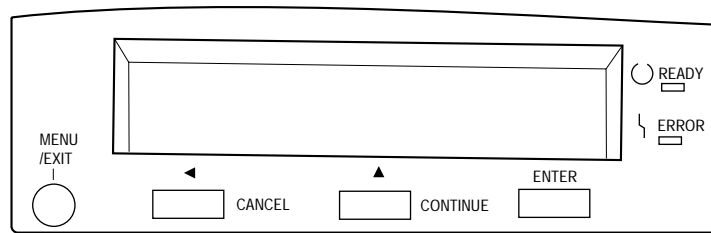

LCD (Liquid Crystal Display) panel

The printer LCD has two 24-character lines to display the printer's status/error messages or menu settings.







Activity lights

The activity lights indicate the status of the printer. They have the following meanings:

This light	Indicates
	READY indicator (green) — <ul style="list-style-type: none">• ON: the printer is ready for operation.• Blinking: the printer is warming up or in the Menu mode.• Blinking fast: the printer is printing.
	ERROR indicator (orange) — <ul style="list-style-type: none">• ON: an internal error ("Call for Service" error) has occurred.• Blinking: user correctable error, such as media jam, open door, or a missing replaceable component (e.g. Toner) has occurred.

Buttons

The printer panel's buttons have the following meanings:

This button	Indicates
	<p>MENU/EXIT button—</p> <ul style="list-style-type: none"> • When the printer is ready, pressing this button enters the Menu mode. • Pressing this button exits the Menu mode.
	<p>◀/CANCEL button—</p> <ul style="list-style-type: none"> • Pressing this button cancels the data in the printer. • When the printer is in the Menu mode, pressing this button: <ul style="list-style-type: none"> —Displays the previous menu, item or selection. —Decreases the current numerical value of the selection. —Moves the cursor to left.
	<p>▲/CONTINUE button—</p> <ul style="list-style-type: none"> • When the printer is in the Menu mode, pressing this button: <ul style="list-style-type: none"> —Displays the next menu, item or selection. —Increases the current numerical value of the selection. • When the Semi Automatic Duplex option is selected in the printer driver, press this button to print on the opposite side of page. (See the <i>Utilities and Drivers Reference Guide</i>.)
	<p>ENTER button—</p> <p>This button is effective only when the printer is in the Menu mode. Pressing this button:</p> <ul style="list-style-type: none"> —Enters a sub - menu. —Activates a selection.

This chapter describes setting up the KX-PS8100 system, connecting it to a computer, and powering on the printer.

Setting up the printer

The general steps for setting up the printer are:

- “Preparing the color imaging unit” on page 40
- “Setting up the output tray” on page 41
- “Installing the toner cartridges” on page 42

Preparing the color imaging unit

After you have unpacked the printer and located it on a flat, stable surface, you need to set it up.

To prepare the color imaging unit:

- 1** Open the printer's front door.

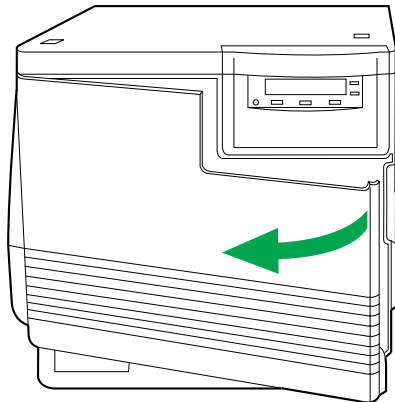

- 2 Turn the upper green lever clockwise until it stops and the arrows are aligned.

This tightens the internal belts to ready the unit for printing.

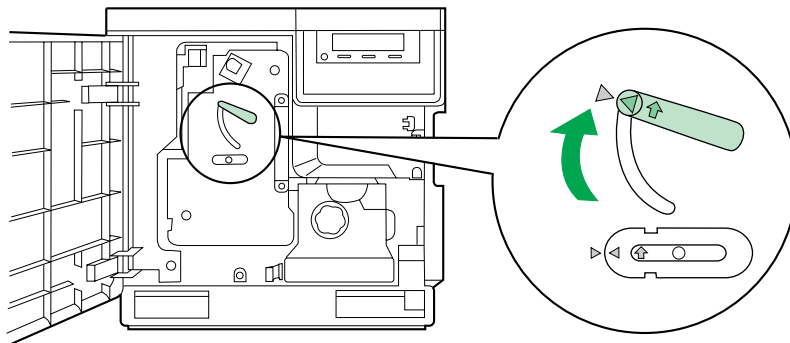

- 3 Close the printer's front door.

Setting up the output tray

Make sure that you have enough room for the output tray and that it is easy to access.

To set up the output tray:

- 1 Remove the adhesive tape that holds the output tray against the printer.

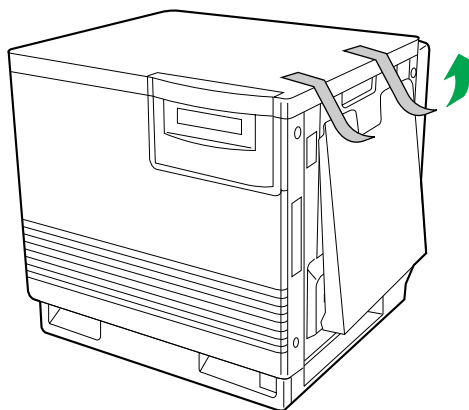

- 2 Lower the tray to the operating position.

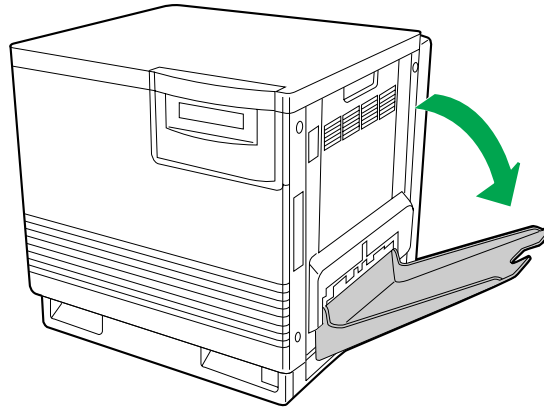

Installing the toner cartridges

The toner cartridges that are shipped with the printer are starter cartridges. They are installed in exactly the same manner as the optional cartridges; the only difference is that the starter cartridges have less toner. The page life expectancy is 3,000 pages, based on a 5% image area.

NOTE:

- Save all packing material for shipping purposes.

To install the starter cartridges:

- 1 Remove the packaging from the each toner cartridge.
- 2 Remove the shipping cover from the each toner cartridge.

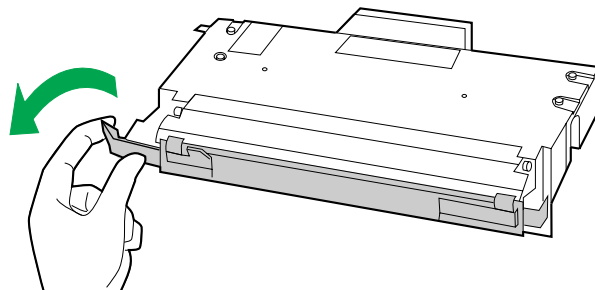

CAUTION:

- To avoid possible toner spillage, do not tilt cartridge.

3 Open the right side door.

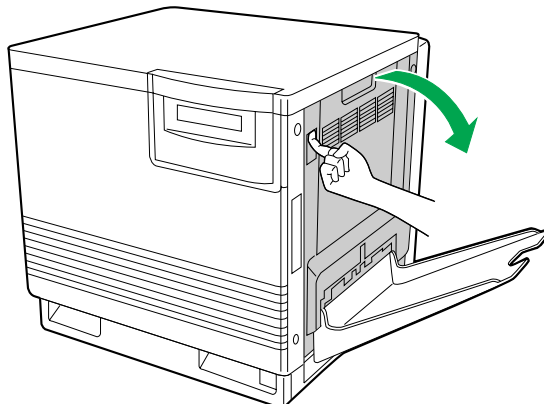

CAUTION:

- Do not leave the right side door open for more than 1 minute; the color imaging unit will be exposed to light and could be damaged.

4 Insert the each toner cartridge in the appropriately labeled slot.

From top to bottom, the order of the toner cartridges is BLACK, CYAN, MAGENTA, and YELLOW.

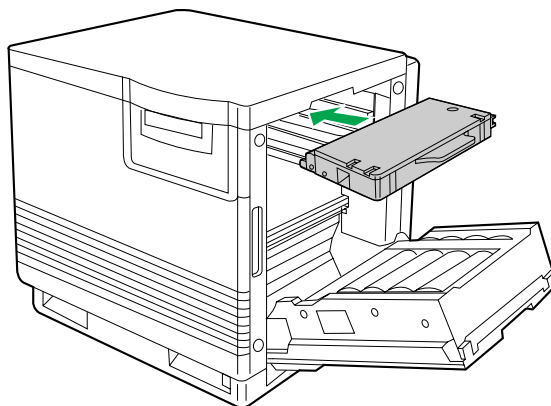

- 5** When you have installed all the toner cartridges, close the right side door.

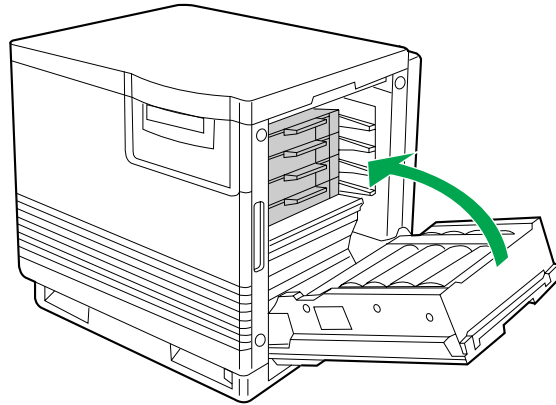

Setting up the scanner

The general steps for setting up the scanner are:

- “Unlocking the scanner” on page 44
- “Installing the scanner on the printer” on page 45
- “Installing the Automatic Document Feeder” on page 47

Unlocking the scanner

The scanner must be unlocked before it can be used. The scanner lock is located on the left of the scanner.

To unlock the scanner:

- 1** Turn the scanner lock counterclockwise with a flat-blade screwdriver until the lock pops out.

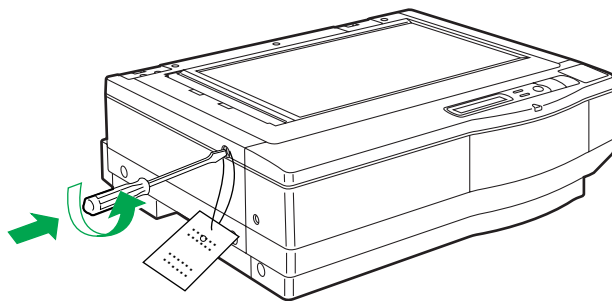

■ Before you begin

The scanner can be installed using two methods:

Method A. On top of the printer

Method B. On left or right side of the printer

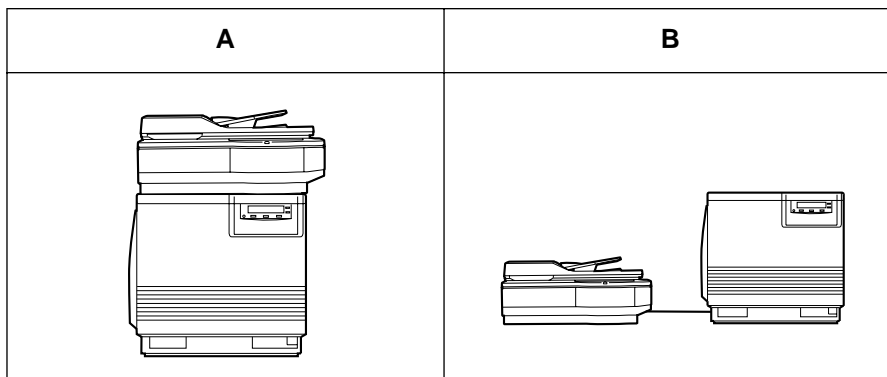

For Method A, see “Installing the scanner on the printer” on page 45 and see “Installing the Automatic Document Feeder” on page 47.

For Method B, see “Installing the Automatic Document Feeder” on page 47.

Installing the scanner on the printer

To install the scanner on the printer:

- 1 Remove the two top hole covers with a small flat-blade screwdriver, then remove the two screws from the printer.

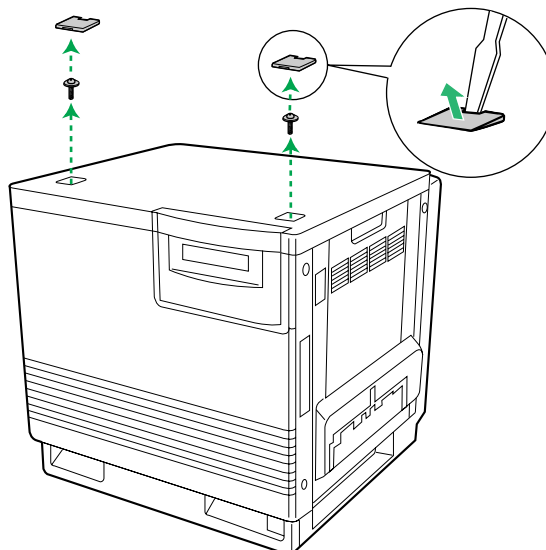

- 2** Install the guide pins and tighten them with a flat-blade screwdriver.

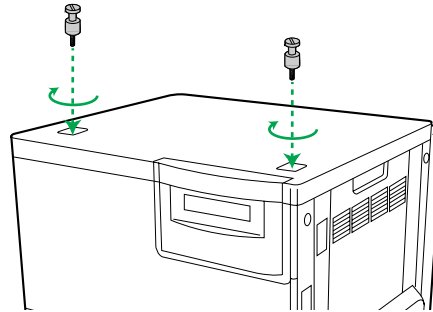

- 3** Match the guide pins to the holes under the scanner, and place the scanner gently onto the printer.

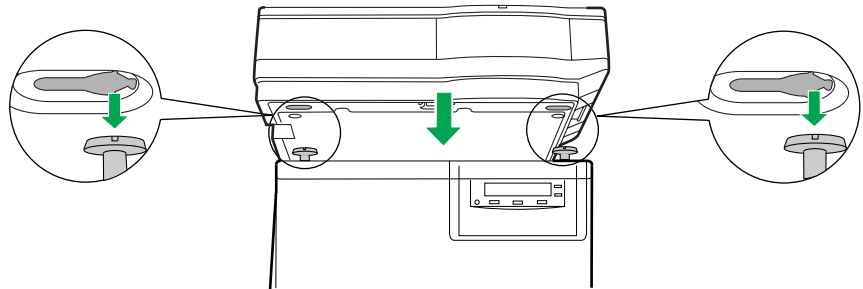

SAFETY CAUTIONS:



- The scanner without ADF weighs approximately 18.5 kg {38.1 lbs.}. It must be handled by two people.
- When you place the scanner onto the printer, move the scanner holding its handle to avoid injury.

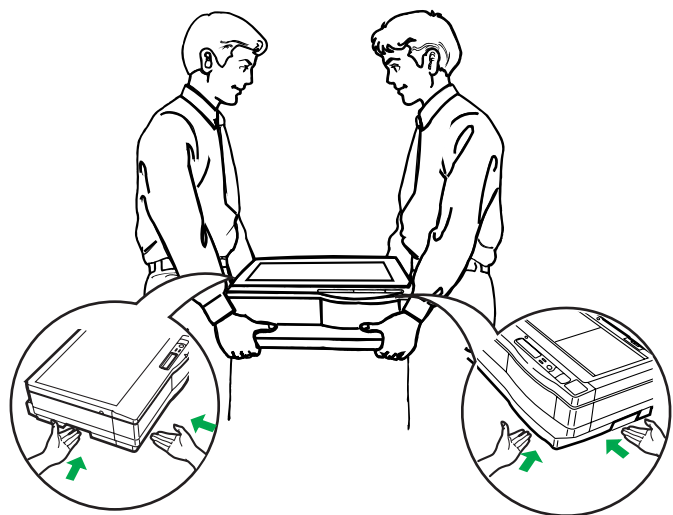

- 4 Lock the scanner by sliding it toward the right.

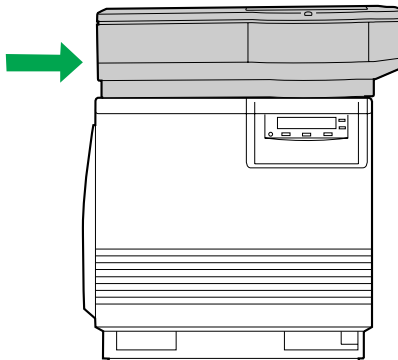

Installing the Automatic Document Feeder

To install the ADF (Automatic Document Feeder):

- 1 Hold the ADF vertically, then insert the tabs into the holes on the rear of the scanner.

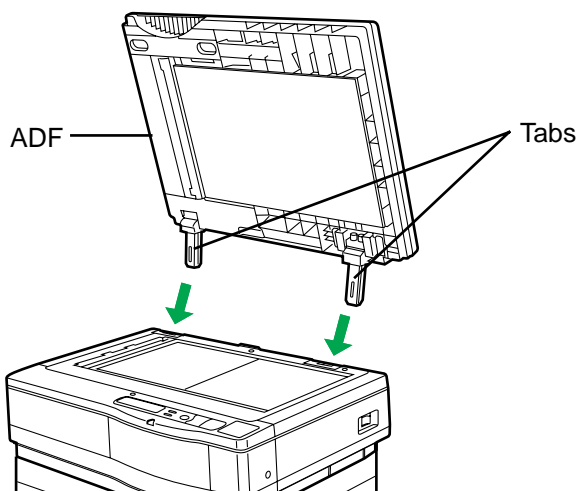

- 2 Close the ADF.

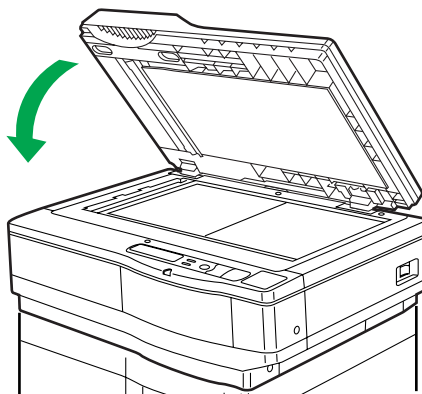

- 3 Plug the end of the ADF cable into the ADF connector located on the back of the scanner.

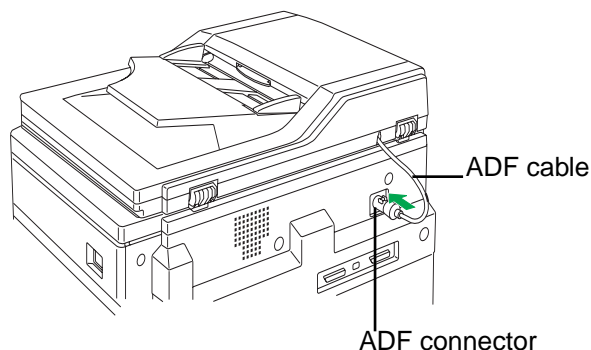

Loading media

The printer is shipped with one media tray (either Letter Paper or A4 Paper) installed, however the printer supports five different trays as shown in the following table.

Tray	Size
A4 Paper	210 mm x 297 mm (8.3" x 11.7")
A4 Transparency	210 mm x 297 mm (8.3" x 11.7")
Letter Paper	216 mm x 279 mm (8.5" x 11")
Letter Transparency	216 mm x 279 mm (8.5" x 11")
Legal Paper	216 mm x 356 mm (8.5" x 14")

NOTES:

- Make sure that you load the correct media. Each tray is designed and labeled for **only** paper or transparency. If you load the incorrect media type in a tray, it may cause a jam.
- If you have the 2nd cassette feeder (option) installed and you wish to use the automatic cassette-switching feature (for a large print job, for example), make sure that all trays in the printer are the **same** media type and size.
- The transparency tray should only be inserted in the upper or middle tray slots.
- **Do not use a ink jet transparency** that may be wrapped around the fuser roller and cause damage.

- **The recommended transparency is 3M CG3710.**

The transparency has a side to be printed. The other side has a leading tape.

When loading the transparency, load it with the taped end entering the printer first.

The transparency can be loaded in the multi-purpose tray and transparency tray (option). To get better print result, use the transparency tray. Note that the side to face up differs depending on each tray.

To load paper or transparencies:

1 Pull the media tray out of the printer.

To use an appropriate media tray, always check the label indication on the tray.

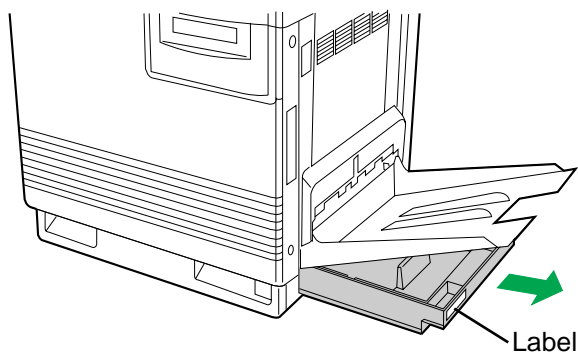

2 Remove all packaging materials from inside the media tray; refer to the instruction sheet attached to the tray.

3 Push down on the metal plate until it clicks, locking it in place.

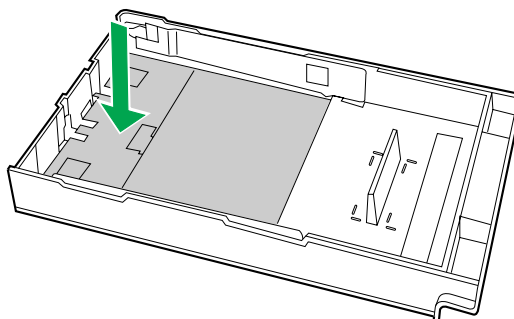

- 4** Fan the media (paper or transparencies), and then tap it on a level surface to avoid media jams or skewed printing.

Do not fan the transparency to avoid fingerprints.

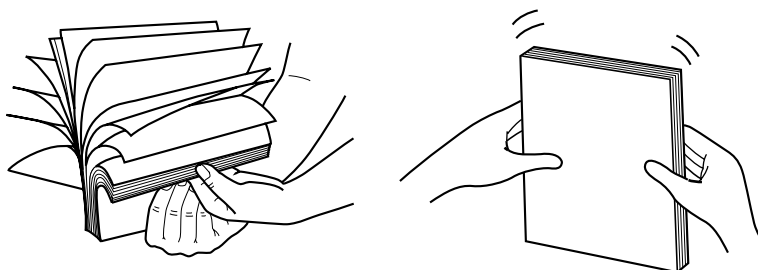

NOTES:

- To optimize your printer's performance, always use clean, unused media.
- Be careful not to leave fingerprints on the media, which can result in a smudged print.
- Reusing media that has been fed through the printer once (for example, after jams) can reduce the life of the consumables and paper path components.

- 5** Place the media in the tray under the hooks.

The height of media should not exceed the limit mark on the tray, or it may cause a jam.

When loading the *recommended transparency (3M CG3710)*, load it with the leading tape side facing up and the taped end under the hooks. (See the illustration below.)

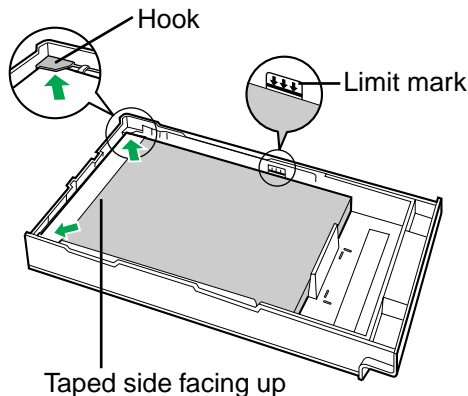

NOTES:

- Load media with the print side down. Most media has instructions recommending the side to be printed first.
- Do not mix different types or thicknesses of media in the media tray at one time; this may cause a jam.
- When using transparency, be sure to use the transparency tray.

6 Slide the media tray completely into the slot.

7 When using transparency with leading tape:
Remove the tape after printing.

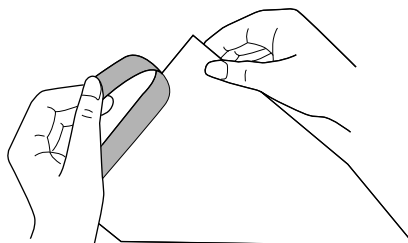

Margins and print area

When the image is printed on the media, the image (print area) is a bit smaller than the media size. You may need to adjust the page margins in the application software to match the print area.

The following table and illustrations show the page sizes, the largest print areas, and the margins for the media sizes supported on this printer.

Media	Page Size	Print area	Margins		
			Top	Bottom	Sides
Letter	216 mm x 279 mm (8.5" x 11")	208 mm x 270 mm (8.2" x 10.6")	4.2 mm (0.17")	4.3 mm (0.17")	3.9 mm (0.15")
A4	210 mm x 297 mm (8.3" x 11.7")	201 mm x 289 mm (7.9" x 11.4")	3.4 mm (0.13")	3.9 mm (0.15")	4.3 mm (0.17")
Legal	216 mm x 356 mm (8.5" x 14")	208 mm x 346 mm (8.2" x 13.6")	3.2 mm (0.13")	6.0 mm (0.24")	3.9 mm (0.15")

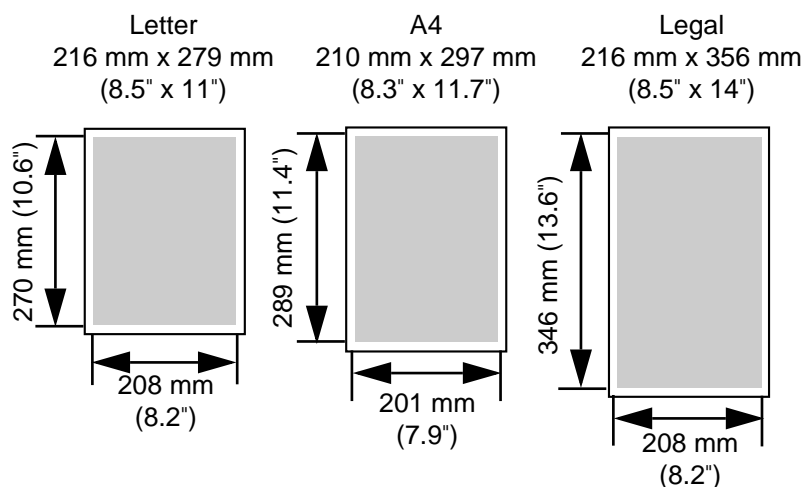

Loading media in the multi-purpose tray

The multi-purpose tray (MPT) serves as an additional tray for loading any type of media that ranges in size from 91 mm x 254 mm to 216 mm x 356 mm (3.6" x 10" to 8.5" x 14"). Use it to load a single sheet or a stack of media, depending on the media's type and thickness.

Use the multi-purpose tray to accomplish the following:

Print on standard and special media

- Standard media
 - Laser paper [75 to 165 g/m² (20 to 44 lbs.)]
- Special media
 - Labels
 - Envelope (#10 or larger size) [Black Text only]
 - Transparency (The print quality may not be stable. Use the media tray for best reliability.)
 - Coated paper

Two-sided printing (Duplex printing) on laser paper

You should not expect the same print quality and reliability that you get with one-sided printing. For details, see ["Two-sided printing \(Duplex printing\)" on page 292](#).

To set media thickness switch:

Because the printer accommodates various media weights from the multi-purpose tray, media thickness can be manually selected for the most reliable paper-picking. Follow these steps:

- 1**
 - a) Open the left side door.
 - b) Move the switch to the desired setting.

The green media thickness switch is located on the paper feeder and has three settings:

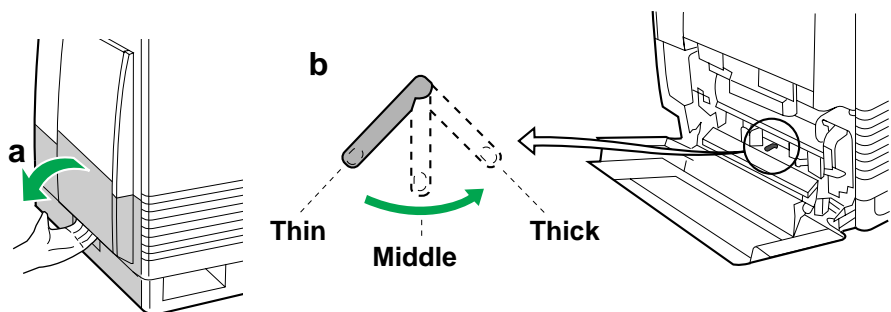

Switch setting	Media
Thin (Default)	Laser paper 75 to 90 g/m ² (20 to 24 lbs.)
Middle	Laser paper 91 to 123 g/m ² (25 to 32 lbs.) Transparency, Label, Coated paper
Thick	Laser paper 124 to 165 g/m ² (33 to 44 lbs.) Envelope

2 Close the left side door.

To load paper, transparency:

NOTE:

- Reusing media that has been fed through the printer (for example, after jams) can reduce the life of the consumables and paper path components.

For detailed information on media, see ["Media" on page 290](#).

- 1** Set the media thickness switch (see page 52).
- 2**
 - a) Open the multi-purpose tray.
 - b) Extend the media support by sliding it outward.

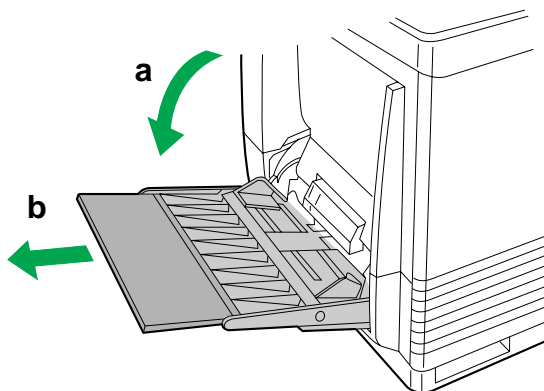

- 3** Separate the media guides to the approximate width of the media.

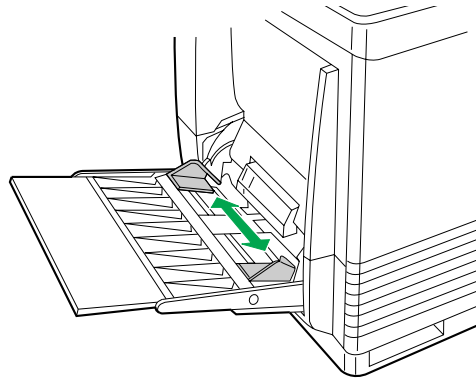

- 4** Fan the media, and then tap it on a level surface to avoid media jams or skewed printing.

Do not fan the transparency to avoid fingerprints.

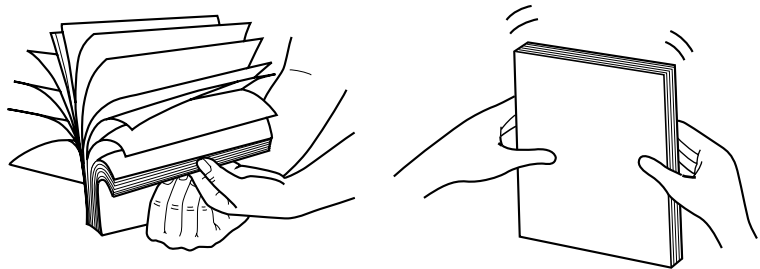

- 5** Insert the media with the printing side up into the multi-purpose tray.

The height of media should not exceed the limit mark on the left guide, or it may cause a media jam.

When loading the **recommended transparency (3M CG3710)** in the multi-purpose tray, loading it with the leading tape side facing down and the taped end entering the printer first. (See the illustration below.)

NOTE:

- **Do not use a ink jet transparency** that may be wrapped around the fuser roller and cause damage.

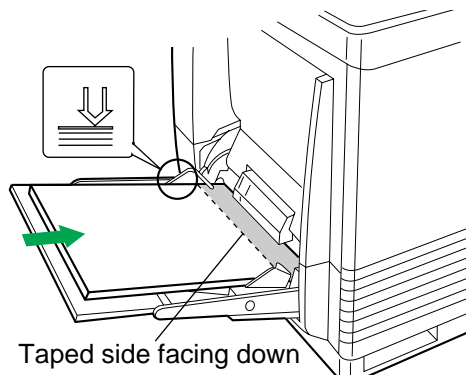

- 6 Adjust the media guides to the media size.
- 7 Use the printer driver to select the multi-purpose tray.
- 8 When using transparency with leading tape:
Remove the tape after printing. (See page 51.)

To load an envelope in the multi-purpose tray:

Do not insert more than one envelope at a time. Only black text can be printed on envelopes. For more detailed information, see “■ Envelopes” on page 294.

- 1 Set the media thickness switch (see page 52).
- 2 Adjust the media guides to the width of the envelope.
- 3 Insert the envelope with the short end entering the printer first and the printing side facing up.
The edge where the stamp will be located enters the printer first.

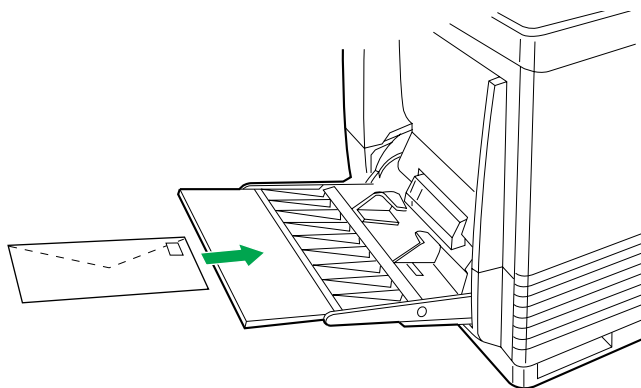

NOTE:

- When wrinkle occurs, try printing with the envelope flap tucked in as shown below.

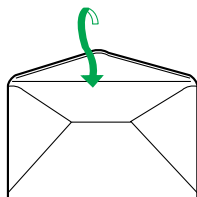

- 4 From your computer, use the printer driver to choose **Envelope** from the **Paper Size** menu and **Paper Source** menu.

To load labels in the multi-purpose tray:

For detailed information on labels, see “■ Transparencies and labels” on page 293.

- 1** Set the media thickness switch (see page 52).
- 2** Adjust the media guides to the width of the label sheets.
- 3** Insert label sheets in the multi-purpose tray with the printing side up and insert the top of the sheets first.
The height of labels should not exceed the limit mark on the guide.
- 4** Choose **MPT Label** as the paper source in the **Paper** tab of the printer driver.

NOTE:

- Avoid printing labels if the temperature is too high; doing so may damage consumables.

Connecting the system

The scanner, printer, and computer can be installed in different configurations depending on the function(s) to be used or computer system to be connected.

■ Digital Color Imaging System (DCIS) standard system

(See pages 60, 64 and 70.)

The printer must be connected to computer through the **Parallel port** (local port) or **Network port** to print documents. You cannot print documents using the SCSI connection.

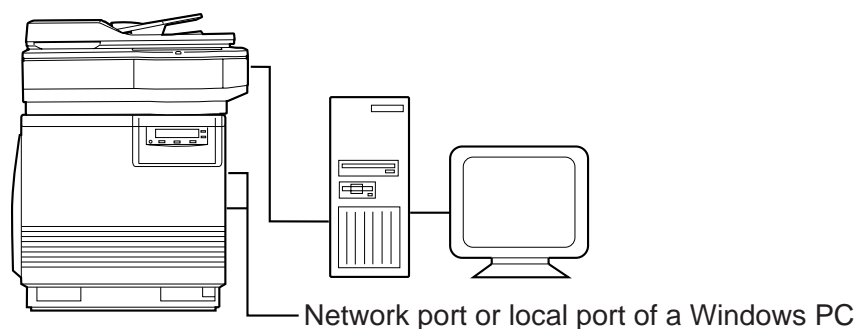

Functions	Windows	Mac
Scanning Documents	Yes	Yes
Printing Documents	Yes* ¹	Yes* ²
Duplicating Documents	Yes	Yes* ³

*¹Only when using Parallel port (local Port) or Network port.

*²Only when using Network port.

*³Duplicating Documents using Digital Duplicator Utility is not available. Duplicating Documents using scanner panel is available.

■ Connecting the scanner to a computer

(See page 62.)

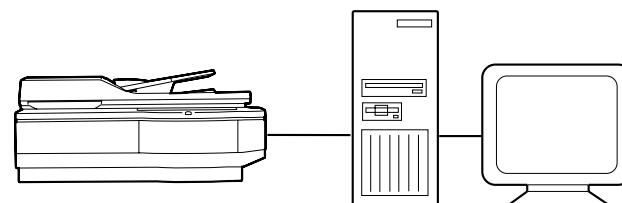

Function	Windows	Mac
Scanning Documents	Yes	Yes

■ Connecting the printer to a local port of a Windows PC

(See page 64.)

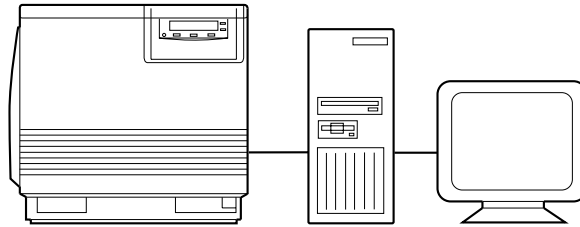

Function	Windows	Mac
Printing Documents	Yes	No

■ DCIS stand alone system

(See page 65.)

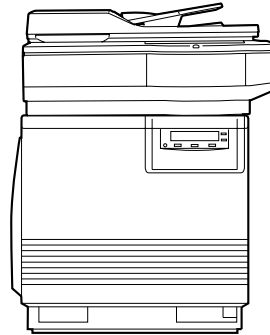

Function	Availability
Scanning Documents	No
Printing Documents	No
Duplicating Documents	Yes

■ Connecting the printer to a network port

(See page 70.)

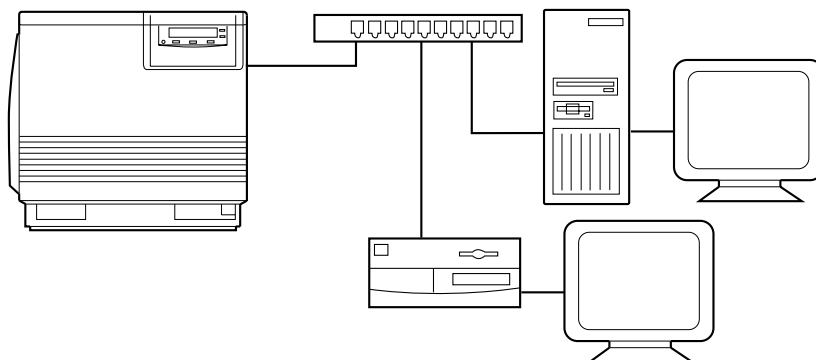

Function	Windows	Mac
Printing Documents	Yes	Yes

Digital Color Imaging System (DCIS) standard system

If a SCSI-2 board has been installed in your computer, be sure it is compatible (see “SCSI interface” on page 298). If it is not installed, be sure to install only a recommended SCSI-2 board (see page 29).

If you do not have a SCSI cable, you will need to purchase one from your local computer store or dealer (see “SCSI interface” on page 298).

Recommendation for connecting DCIS:

- We recommend you to connect your DCIS with only one SCSI device.
- For a SCSI chain with up to three SCSI-2 (FAST SCSI) devices connected, the total length of the SCSI cables must be less than 3 m (9.8 ft.).
- Use shielded cables for SCSI-2 (FAST SCSI).

NOTE:

- Although a SCSI chain may exceed the recommended length and still operate we cannot guarantee this operation.

- 1** Make sure the computer, scanner, printer and the other connected peripheral devices are turned off.
- 2** Connect the SCSI cable (not provided) to the computer’s SCSI connector and to the scanner’s SCSI connector A or B.

The SCSI-2 board must be installed in the computer.

If you do not have a SCSI-2 board or a SCSI cable, you will need to purchase one from your local computer store or dealer (see “SCSI interface” on page 298).

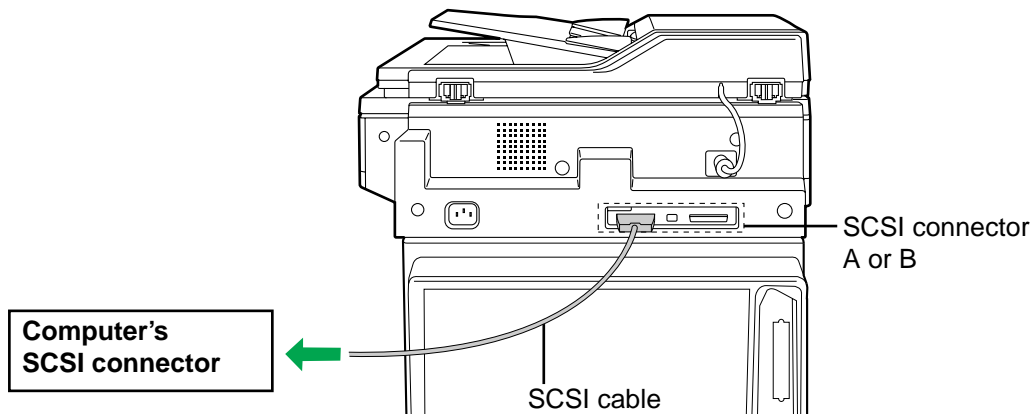

3 Connect the SCSI cable provided to the printer's SCSI connector and to the scanner's SCSI connector.

The printer must be the last device in the chain because the printer has only one SCSI connector.

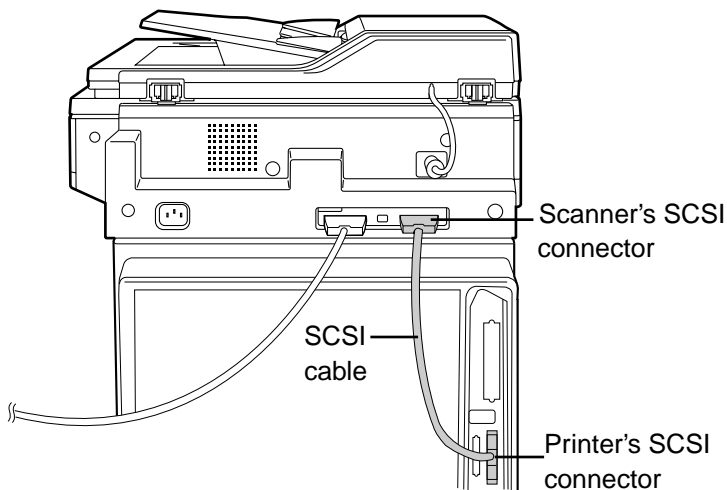

4 Make sure the SCSI ID No. of the scanner is 2 and that of the printer is 1. (They are the default settings.)

- If you have other devices connected to the computer, make sure that each SCSI device has a different ID No.
- To change an ID No., use ID No. switches (#1, #2, #3) located on the back of the scanner or ID No. switches (#2, #3, #4) located on the back of the printer. See Table 1 on [page 66](#).

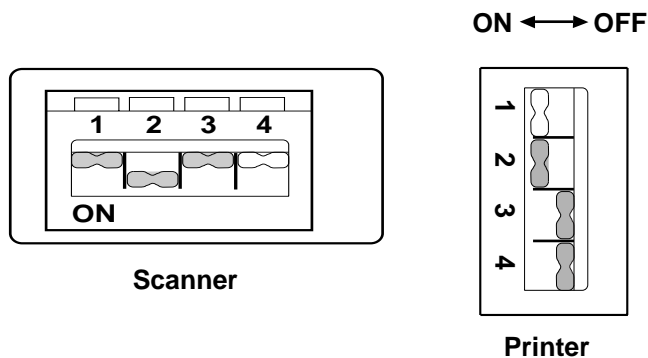

5 Make sure the terminator switch (#4) of the scanner is set to OFF and that switch (#1) of the printer is set to ON. (They are the default settings.)

- If you have other devices connected to the computer, make sure the terminator switches of all those devices are set to OFF.
- To change the terminator setting, use the terminator switch located on the back of the units.

- 6** Connect the power cords to the scanner's AC inlet, to the printer's AC inlet and to AC outlets.

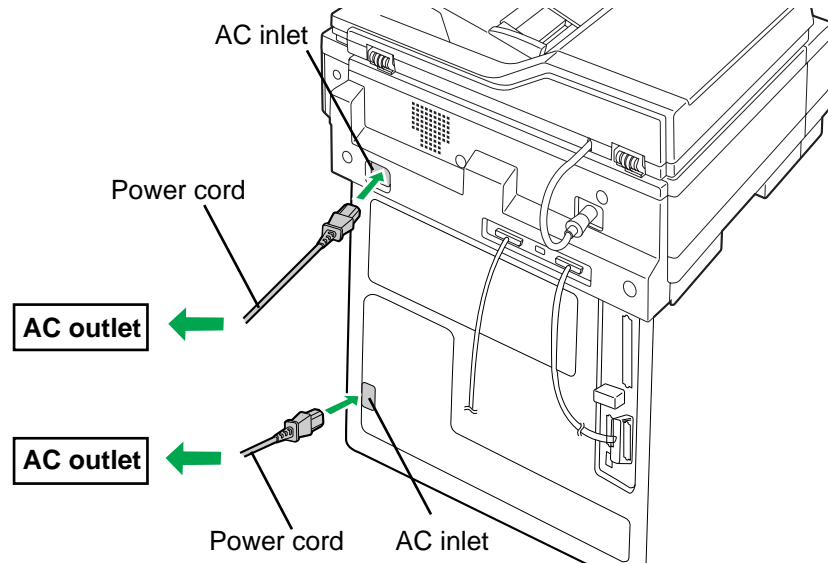

Connecting the scanner to a computer

NOTE:

- The terminator must be installed or set to ON on the last SCSI device only (see page 66).

- 1** Make sure the computer, scanner and the other connected peripheral devices are turned off.
- 2** Connect the SCSI cable (not provided) to the computer's SCSI connector and to the scanner's SCSI connector A or B.
- The SCSI-2 board must be installed in the computer. If you do not have a SCSI-2 board or a SCSI interface cable, you will need to purchase one from your local computer store or dealer (see "SCSI interface" on page 298).
 - If other SCSI devices are connected to the computer, connect the scanner anywhere in the SCSI chain.

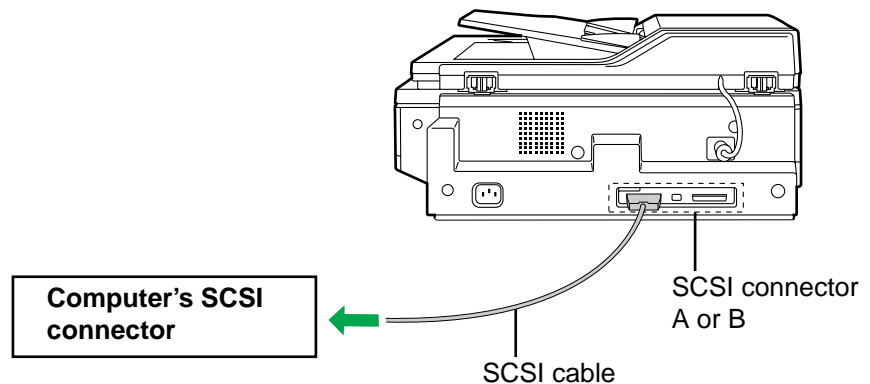

3 Make sure the SCSI ID No. of the scanner is 2 (default setting).

- If other devices are connected to the computer, make sure that each SCSI device has a different ID No.
- To change the scanner's ID No., use the ID No. switches (#1, #2, #3) located on the back of the scanner. See Table 1 on [page 66](#).

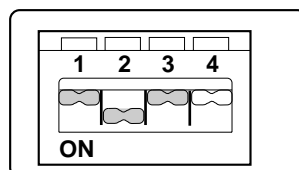

4a If the scanner is the last device, set its terminator switch (#4) to ON. Go to step 5.

4b If the scanner is not the last device, make sure the terminator switch (#4) is set to OFF (default setting).

5 Connect the power cord to the scanner's AC inlet and to an AC outlet.

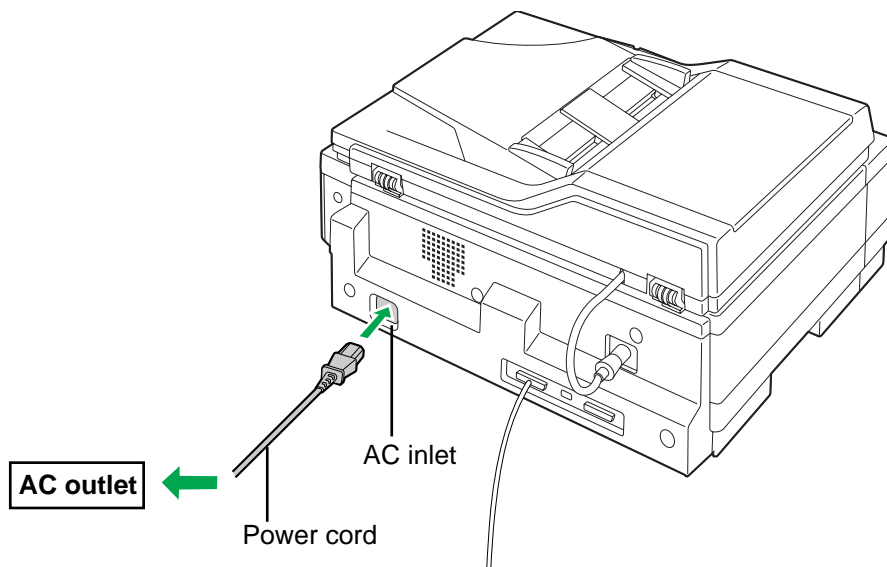

Connecting the printer to a local port of a PC

CAUTION:

- Always use a shielded interface cable. Use of an unshielded cable can result in radio interference with data.

NOTE:

- Printing through a serial port (LocalTalk) is not supported on Macintosh computers.

■ Using a parallel interface cable

If you do not have a parallel interface cable, you will need to purchase one from your local computer store or dealer (see ["Bidirectional parallel interface" on page 296](#)).

- 1** Make sure the computer, printer and the other connected peripheral devices are turned off.
- 2** Connect the Centronics Type C parallel interface cable to the computer's parallel connector and the printer's parallel interface connector.

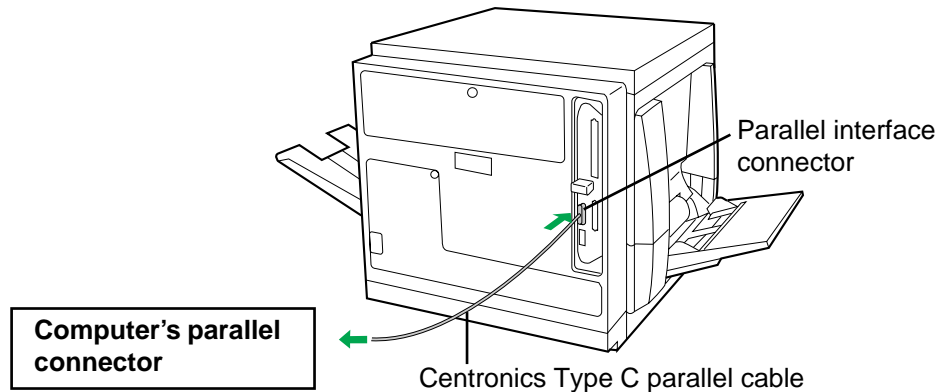

NOTES:

- The actual connector on the computer may differ depending on the manufacturer of the computer.
- If the cable is connected to the PC via a printer buffer or switch, the printer may not print.

- 3** Connect the power cord to the printer's AC inlet and to an AC outlet.

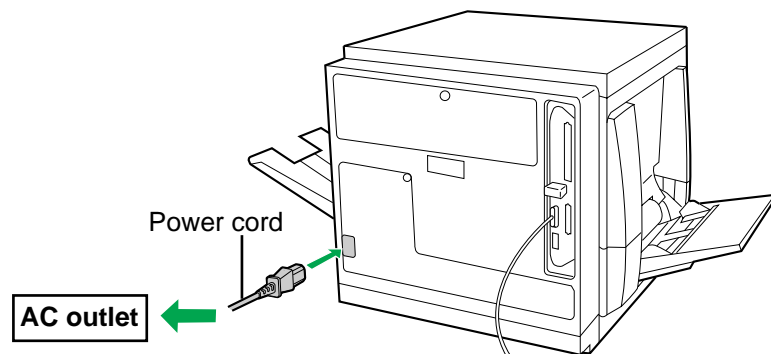

DCIS stand alone system

- 1** Make sure the scanner and printer are turned off.
- 2** Connect the SCSI cable provided to the scanner's SCSI connector A or B and to the printer's SCSI connector.

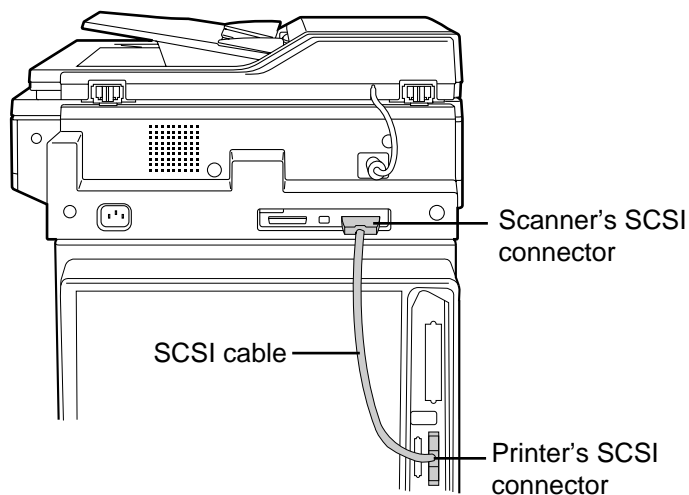

- 3** Make sure the terminator switches (scanner:#4/ printer:#1) are set to ON.

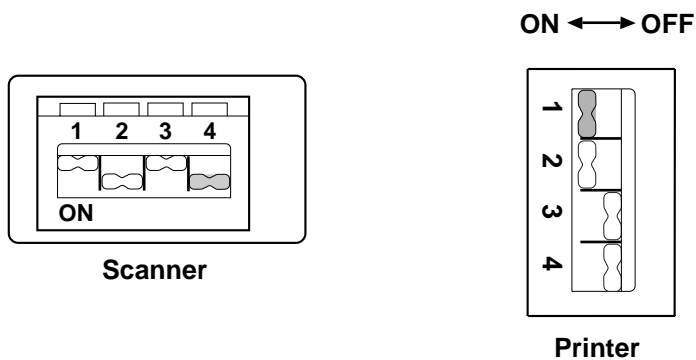

- To change a terminator setting, [see page 66](#).

- 4** Connect the power cord to the scanner's AC inlet and to an AC outlet.
- 5** Connect the other power cord to the printer's AC inlet and to an AC outlet.

NOTE:

- The Printer function is also available if the printer is connected to the computer with a parallel interface cable.

Setting the SCSI ID number and terminator

■ Setting the SCSI ID number

In most cases, there is no need to change the default settings (see Tables 1 and 2 below).

However, if you have other peripheral devices connected in a SCSI chain, check if their ID numbers conflict with that of the printer or scanner. Be sure to choose an unassigned ID number.

SCSI ID number can be changed by using the scanner SCSI ID No. switches (#1, #2, #3) [see Table 1 below] and/or printer SCSI ID No. switches (#2, #3, #4) [see Table 2 below]. To set them, use a pointed object like a pen (do not use pencil).

Table 1 (scanner)

SCSI ID No.	SCSI ID No. switches		
	#1	#2	#3
0	OFF	OFF	OFF
1	ON	OFF	OFF
2	OFF	ON	OFF
3	ON	ON	OFF
4	OFF	OFF	ON
5	ON	OFF	ON
6	OFF	ON	ON
7	ON	ON	ON

■ : Default setting

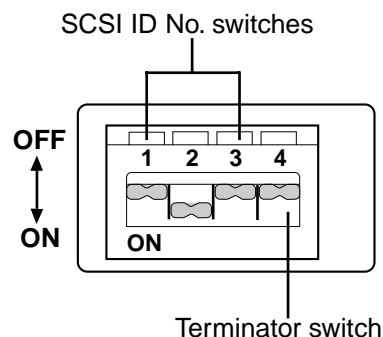

Example:
SCSI ID No.=2
Terminator=OFF

Table 2 (printer)

SCSI ID No.	SCSI ID No. switches		
	#2	#3	#4
0	OFF	OFF	OFF
1	ON	OFF	OFF
2	OFF	ON	OFF
3	ON	ON	OFF
4	OFF	OFF	ON
5	ON	OFF	ON
6	OFF	ON	ON
7	ON	ON	ON

■ : Default setting

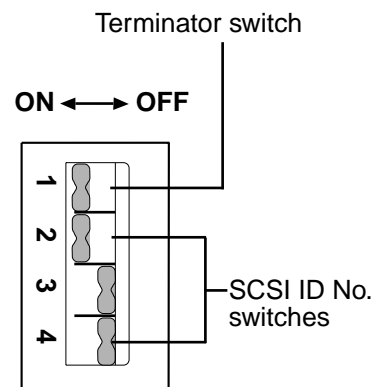

Example:
SCSI ID No.=1
Terminator=ON

■ Setting the terminator

The default setting of the scanner is set to OFF and that of the printer is set to ON.

The terminator setting can be changed by using the terminator switch (scanner:#4, printer:#1). To set it, use a pointed object like a pen (do not use a pencil).

Terminator ON:

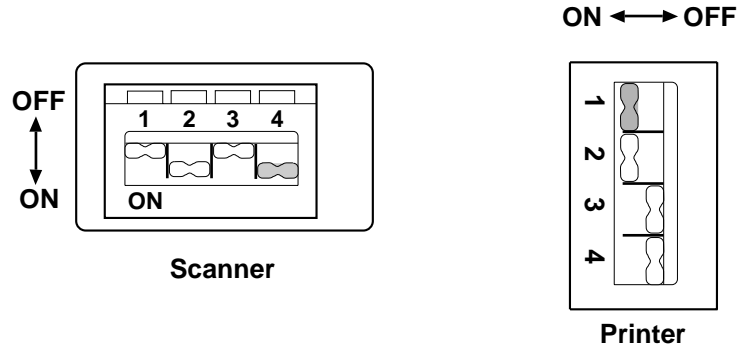

Terminator OFF:

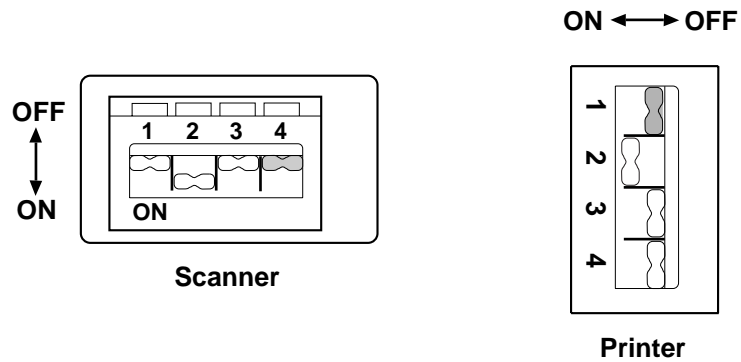

Power on

- 1 Turn ON the scanner, then the printer.

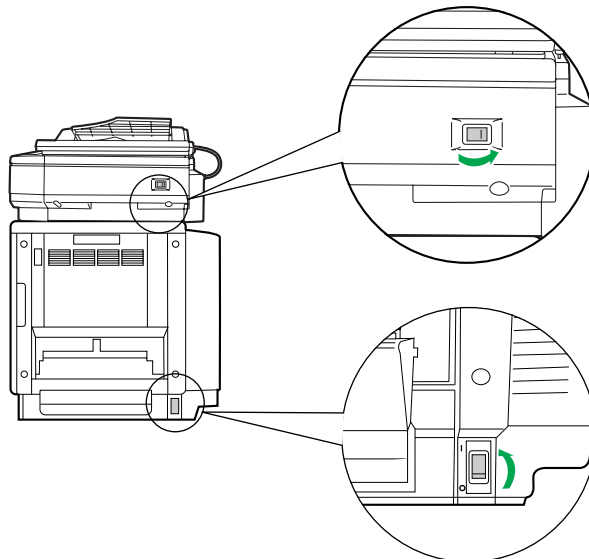

- 2 The scanner will be ready after approximately 20 seconds, and “**Ready**”, “**PTR Initializing**” will be displayed on the scanner LCD panel.
- 3
 - a) The **READY** indicator on the printer starts flashing and “**Initializing**” is displayed on the printer LCD panel.
 - b) After approximately 3.5 minutes, the printer’s **READY** indicator is illuminated and “**Ready**” is displayed on the printer LCD panel.The printer is ready for printing.
- 4 Turn ON the computer after “**Ready**” is displayed on the scanner and printer LCD panels.

NOTES:

- When you power on your system for the first time, if “New Hardware Found” is displayed on the computer screen, [see page 102](#).
- If you use Macintosh 7500/7600/8500/9500, follow the procedure below. KX-PS8100 does not operate properly in the procedure above.
 1. Turn on Macintosh 7500/7600/8500/9500.
 2. Turn on the scanner, then the printer.
 3. Check “Ready” is displayed on the scanner and printer LCD panels.

Printing a Test Print from the printer panel

There are several pages that you can print from the printer panel. This section provides instructions for printing a Test Print.

The Test Print includes a color sample as well as the printer's name, enabled network protocols, memory configurations, and installed options.

You can print a Test Print before you set up the KX-PS8100 system—or at any other time from the “Ready” or the “Ready(Sleep)” screen.

To print a Test Print:

- 1** Turn on the printer and allow it to warm up.
Messages appear on the printer panel as the KX-PS8100 printer runs through its power-up tests.
- 2** From the Ready screen, press the **MENU/EXIT** button on the printer panel.
- 3** Press the **ENTER** button.
- 4** Press the **▲/CONTINUE** button until you see **Test Print** and then press the **ENTER** button.
- 5** Examine the quality of the Test Print.

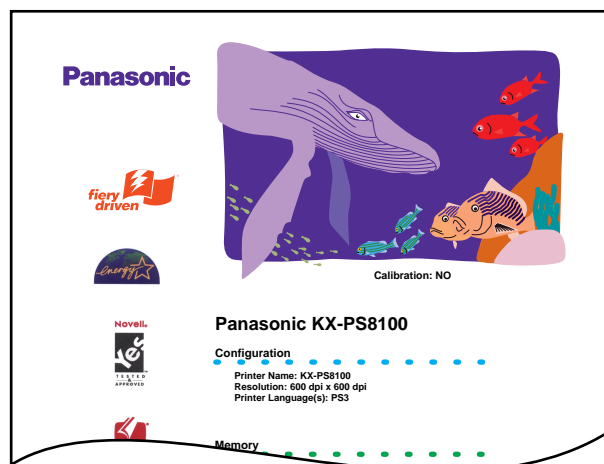

Test Print

For more information, [see page 202](#).

Chapter 3 **Connecting the Printer to a Network**

This chapter describes how to connect your printer to a network. You can connect the printer to your network with thicknet, twisted pair, or thinnet.

This chapter provides information about:

- “Ethernet network connections” on page 70
- “Token Ring network connections” on page 72
- “Setting up TCP/IP printing” on page 73

TCP/IP stands for Transmission Control Protocol/Internet Protocol.

- “Setting up IPX (Novell) printing” on page 82

IPX stands for Internet Packet Exchange.

- “Setting up Windows 95 clients for SMB printing” on page 91
- “Setting up Windows NT 4.0 clients for SMB printing” on page 93

SMB stands for Server Message Block.

After you have connected the printer to the network, follow the setup instructions in [Chapter 6 “Setup from the Printer Panel and WebSetup”](#).

Network connections



This section describes the types of network connections supported by the KX-PS8100 system. Optional network card is available from your Panasonic dealer. For more information on upgrade options, [see Chapter 10 “Options”](#).

IMPORTANT:

- Use a shielded cable when using a RJ45 connector port or an AUI connector port to ensure emission compliance to avoid radio frequency interference.

Ethernet network connections

- Thinnet (thin coaxial cable or 10Base2)
Uses an external transceiver (media access unit, or MAU) to attach to the AUI (attachment unit interface) connector on the printer.
- Thicknet (thick coaxial cable or 10Base5)
Cable connects directly to the AUI connector on the printer.
- Twisted pair (Category 5 shielded twisted pair cable or 100BaseTX)
Uses 8-pin RJ-45 connector that plugs into the RJ-45 jack on the printer.

NOTE:

- Category 3, shielded twisted pair cable is supported on 10BaseT networks.

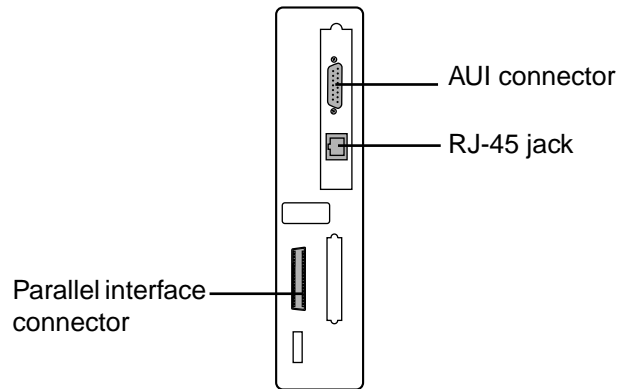

NOTE:

- Shut off the printer before connecting it to any network device. Only one Ethernet connection should be made to the printer at a time.

To connect a thinnet cable to the printer:

- 1** Make sure the computer, printer and the other connected peripheral devices are turned off.
- 2** Connect the MAU transceiver to the AUI connector on the back of the printer. Secure the connection using the slide latch on the AUI connector.
- 3** Connect the thinnet cable to the BNC connector on the transceiver.
- 4** Turn on the printer and then the computer.

To connect a thicknet cable to the printer:

- 1** Make sure the computer, printer and the other connected peripheral devices are turned off.
- 2** Connect the thicknet cable connector to the AUI connector on the back of the printer.
- 3** Turn on the printer and then the computer.

Connecting the Printer to a Network

To connect a twisted pair cable to the printer:

- 1** Make sure the computer, printer and the other connected peripheral devices are turned off.
- 2** Connect the RJ-45 cable to the RJ-45 jack on the back of the printer.
- 3** Turn on the printer and then the computer.

For Ethernet speed setting, see [“Network Port Setup” on page 146](#).

Token Ring network connections



The printer supports the shielded twisted pair cable (Category 5 shielded twisted pair cable) that plugs into the RJ-45 jack on the back of the printer.

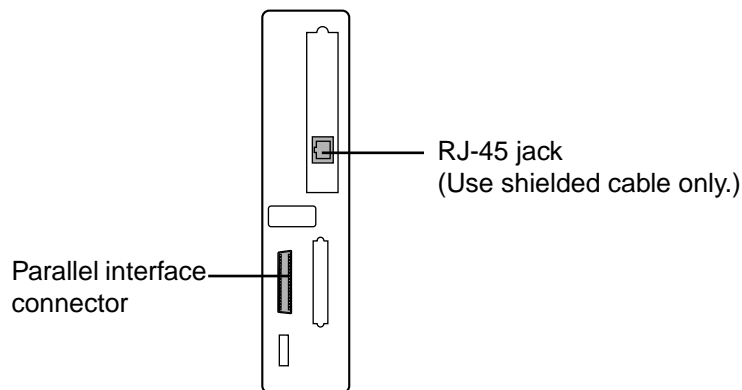

To connect the cable to RJ-45 jack on the printer:

- 1** Make sure the computer, printer and the other connected peripheral devices are turned off.
- 2** Connect the cable from the Token Ring MAU (Media Attachment Unit) to RJ-45 jack on the back of the printer.

NOTE:

- A Media Attachment Unit (MAU) is a network hub for a Token Ring Network.

- 3** Turn on the printer and then the computer.

For Token Ring settings, see [“Network Port Setup” on page 146](#).

Setting up TCP/IP printing



TCP/IP provides network services for high-speed local and wide area networks and heterogeneous environments including PC compatibles, Macintosh computers, minicomputers, and mainframes running diverse operating systems. The printer supports the lpr protocol for printing over TCP/IP networks. Network users submit print jobs to a named printer. Workstations on a TCP/IP network can print directly to the printer, or can print to a Windows NT 4.0 server or UNIX workstation acting as a print server.

Before you install the printer on a TCP/IP network, you need to obtain a unique IP address. Contact your network administrator for this information.

Setting up the printing environment

To set up printing on a TCP/IP network, the network administrator must follow these steps:

To set up IP Address/Subnet mask on the KX-PS8100:

- 1** From the **Ready** screen, press the **MENU/EXIT** button on the printer panel to access the printer setup menus.
- 2** Press the **▲/CONTINUE** button until you see **Network Protocol Setup** on the printer LCD panel. Press the **ENTER** button to access the **TCP/IP Setup** menus.
In the next step you will enable TCP/IP network communication according to your network type.
- 3** Press **ENTER** button to advance to the **Enable TCP/IP?** screen. Press **ENTER** button and press **▲/CONTINUE** button to select **Yes**, and then press **ENTER** button again to advance to the **Ethernet IP Address** screen. Press **ENTER** button.

Connecting the Printer to a Network

- 4 Use the **▲/CONTINUE** button to select a number in a valid, unique IP Address for the KX-PS8100. Press **◀/CANCEL** button to accept a number and move to the left—to the next number.

NOTE:

- On the printer, numbers are entered from right to left. Press the **▲/CONTINUE** button to scroll through numbers from 0 to 9. Press the **◀/CANCEL** button to accept a number and move to the next.

- 5 When you have finished entering all numbers in the address, press **ENTER** button to advance to the **Subnet Mask** screen. Press **ENTER**.

- 6 Use the **▲/CONTINUE** button to select a number as the Subnet Mask value for the KX-PS8100. Press **◀/CANCEL** button to accept a number and move to the left—to the next number.

- 7 Specify the Gateway Address in the printer's Setup menus, if needed.

See "Network Protocol Setup" on page 148 for details.

- 8 When you have finished entering all numbers, press **MENU/EXIT** button.

After being rebooted, the printer will return to Ready mode.

■ Setting up NIS server

If the site is using NIS (Network Information Services), a superuser must add the printer name and IP address to the system's database of network printers.

- 1** Add the KX-PS8100 to the network's IP host table.
This step must be performed on the master NIS (server) machine. After adding the printer entry, the updated database must be released to network users.
- 2** For the printer name, specify the print server protocol, the print connection (queue), and the spool file.
- 3** Activate the printer connection.
Depending on your system, you may restart the printer daemon or tell the printer to accept print requests.

■ Print queues

Print spooling is the process of sending print jobs to a defined location on a hard disk, in this case the Print or Hold queues. Printers without a hard disk drive can only receive print jobs over the Direct connection. Jobs sent to the Direct connection are transferred from the computer to the printer's SDRAM.

NOTE:



- If the printer has a hard disk drive and 32 MB of memory installed, Direct, Print, and Hold print connections are automatically available. If the printer does not have a hard disk drive, only the Direct connection is available.

UNIX server print queues



The lpr protocol is a printer spooling system. It is a set of programs that accepts printing requests from many users on a network, routes them to the proper print server (in this case, the KX-PS8100), and accepts requests to display a queue's status or to remove jobs from a queue.

The lpr system is included in the standard installation of Berkeley-based UNIX systems, SunOS 4, and Solaris.

Use the examples that follow as a guide in helping you set up your network for printing to the printer.

NOTE:

- In these examples, KX-PS8100 is used as the printer name (the IP hostname), and KX-PS8100q is used to indicate the KX-PS8100 Print queue.

Connecting the Printer to a Network

Since the printer supports only one TCP/IP (lpr) connection at a time, you can use the same name for the hostname and the queue name. However, the examples indicate where you should make a distinction if you want to use different names.

To add the printer as a network printer to all UNIX systems:

- 1** Log in to your UNIX host as the root user.
- 2** Edit your **/etc/hosts** file to include the printer as a network device.

The following is a sample entry for the printer:

```
192.9.228.1<TAB>KX-PS8100<TAB>#comments
```

where <TAB> indicates that you press the tab key.

The IP address is followed by the official hostname, and these are followed by aliases, if any. Type the entry exactly as shown, without a space before the IP address.

NOTE:

- For sites that use DNS (Domain Name System) or that use NIS or NIS+, consult the documentation or the network administrator for instructions on publishing the printer entry.

- 3** Save and exit the hosts file.
- 4** Confirm the connection using the **ping** command.
See [“Verifying the TCP/IP network connection” on page 79](#).
- 5** If your UNIX system uses SunOS 4 or another BSD-based variant, go to the next section.
If your system uses Solaris 2, follow the steps on [page 78](#).

To set up printing on a UNIX system running SunOS 4 or another BSD based variant:

1 On each workstation that will print to the printer, log in to your UNIX host as the root user.

2 Create an entry for the printer in your `/etc/printcap` file.

The following is a sample printcap entry for the printer. Note that the remote hostname you enter in the `rm` line must exactly match the name you entered in the `/etc/hosts` file.

```
KX-PS8100q:\
:lp=:\
:rm=KX-PS8100:\
:rp=xjdirect:\
:lf=/var/spool/lpd/KX-PS8100q/log:\
:sd=/var/spool/lpd/KX-PS8100q:\
:mx#0:sf:sb
```

The spool directory `KX-PS8100q` is specified here, and the directory itself is created in [step 3](#). Similarly, the log file is specified here and created in [step 4](#). The spool directory is write-protected (from everyone but a daemon user and daemon group); users cannot modify or remove files other than their own.

It is possible to set up to two additional printer entries, one with the `rp` name `xjprint` and one with the name `xjhold`. The `rp` name indicates the `KX-PS8100` queue to which jobs are sent when you print to the named printer.

A printer entry with the `rp` name `xjhold` routes all jobs to the `KX-PS8100 Hold` queue. Therefore, to print those jobs, they must be moved to the Print queue or deleted using Fiery WebSpooler.

NOTE:

- Use the `rp` name `xjprint` if your `KX-PS8100` has a hard disk, or is configured with more than 32 MB of memory. Printers without a hard disk drive and 32 MB of memory can not use Print or Hold queues (`rp` name: `xjprint` and `xjhold`), they can only receive print jobs over the Direct connection.

3 Create a spool directory for the printer in the `/var/spool` directory.

For example, enter the following:

```
mkdir -p /var/spool/lpd/KX-PS8100q
chown daemon /var/spool/lpd/KX-PS8100q
```

Connecting the Printer to a Network

- 4** Create the log files.
For example, enter the following:

```
cp /dev/null /var/spool/lpd/KX-PS8100q/log
```
- 5** Reboot the machine.

To set up printing on a UNIX system running Solaris 2:

- 1** On each workstation that will print to the printer, log into the UNIX system as the root user.
- 2** At the UNIX prompt, type **lpsystem -t bsd KX-PS8100**
This tells your system that the printer is a print server of bsd (Berkeley Software Distribution) type.
- 3** Type **lpadmin -p KX-PS8100q -s KX-PS8100!\xjdirect**
This command creates an internal queue on the workstation and points it to the printer. The general format of this command is:

```
lpadmin -p <queue name> -s <hostname>!\xjdirect
```

NOTE:

- The name `xjdirect` after the exclamation point is for configuring the printer; it is an internal name that the printer requests. It must be `xjdirect`; it is not a user-selectable name. This is the only place where it is entered.

As with SunOS 4 or other BSD based systems, when printing to printers with a hard disk and a minimum of 32 MB of memory it is possible to configure up to two additional printer entries, one with the `rp` name `xjprint` and one with the `rp` name `xjhold` ([see page 77](#)).

- 4** Type **accept KX-PS8100q**
This command tells the printer to accept print requests from your workstation. You are now ready to print from the workstation to the printer.
- 5** Type **enable KX-PS8100q**

Verifying the TCP/IP network connection

Before a device on a TCP/IP network can send print jobs to the printer, the printer must be given a valid IP address and subnet mask, as well as a gateway address, if applicable. The printer is given these addresses in the printer's Network Protocol Setup. The IP address is used on all TCP/IP networks and must always be assigned before the printer can be verified across the network.

Because TCP/IP networks require some UNIX setup by the network administrator, you may not be able to send a test page from the driver across the network to the printer immediately after installation. The following procedure enables you to verify that there is a proper connection between the printer and the network without using the printer driver to print a test page. Before you begin this procedure, verify that the printer is functioning by printing a page from the printer panel.

For step by step instructions, see ["Printing a Test Print from the printer panel" on page 69](#).

Once the printer's TCP/IP setup is complete, you can verify the availability of the printer using the ping command from the DOS prompt with Windows 95, from the Command prompt with Windows NT 4.0 or from UNIX.

To verify the TCP/IP connection:

To see if the printer responds to its address, use the **ping** command.

Use the format:

```
ping <IP address>
```

Use the printer IP address assigned in Network Protocol Setup. After the printer has been given a hostname by your network administrator, you can also ping the name you gave it:

```
ping <hostname>
```

The server should respond with a message such as:

```
<IP address> is alive.
```

Some systems will respond with a continuous display of output from the IP address. To stop the output, press the **Control** + **C** keys.

Connecting the Printer to a Network

Setting up TCP/IP clients for printing



If the printer is being added to an existing network, each TCP/IP client is already running TCP/IP client software.

The KX-PS8100 printer supports TCP/IP client software on UNIX workstations, PC compatibles, and Macintosh computers. With Macintosh computers however, it is easiest to use the built-in AppleTalk protocol to communicate directly with the printer.

If the client workstation is a PC running Windows, set up the printer as a Windows PostScript printer by installing the PostScript printer driver, as described in [Chapter 4](#). For setting up your networking software, see the documentation for your networking environment.

Setting up TCP/IP clients for running Fiery WebTools



Fiery WebTools software comes pre-installed on the KX-PS8100 printer. Fiery WebTools include: WebSpooler, Status, WebDownloader, WebSetup and WebLink.

When TCP/IP is enabled for the printer in Network Protocol Setup, Fiery WebTools are immediately available to clients that:

- Are connected to a TCP/IP network with a consistent set of IP addresses, one for the printer and one for each computer connect to the printer.
- Have a Java enabled Web browser.

The recommended browsers are:

- Netscape Navigator 3.04 for Macintosh computers,
- Microsoft Internet Explorer 4.0.1 SP1 or Netscape Communicator 4.0.4 for Windows computers.

NOTES:

- Microsoft Internet Explorer 3.x does not support the WebDownloader.
- WebDownloader is not supported on Macintosh computers.

Netscape and Microsoft continue to release frequent updates to their browsers. As support cannot be guaranteed for all versions, use the versions specified above for best results.

To access Fiery WebTools, enter the IP address or DNS name of the printer (KX-PS8101) as a URL in the Internet browser. For more information, [see page 154](#).

Printing and administering print jobs

Once the printer has been properly installed on the TCP/IP network, users should be able to send print jobs to the KX-PS8100 from most applications. UNIX clients also commonly use UNIX printing commands to print PostScript files and text files to the printer.

For information on printing PostScript files and text files using UNIX commands, see Part 3 of *Utilities and Drivers Reference Guide*.

If you have superuser privileges you can remove any lpd jobs from the printer queue; removing your own jobs doesn't require special privileges.

To remove jobs from the printer queue:

On a UNIX system running SunOS 4 or other BSD-based variant, use the **lprm** command to remove jobs from the queue.

To remove job number 123 from the print queue of your KX-PS8100 named printer, you would type:

```
lprm -P<printername> <job #...>
```

or, for example: `lprm -PKX-PS8100 123`

The `lprm` command reports the names of any files it removes.

To determine the job number, use the `lpq` command described below.

```
lpq -P<printername>
```

On a UNIX system running Solaris 2, use the **cancel** command to remove jobs from the queue.

Type:

```
cancel <job ID>
```

For example, to remove a job whose ID is printer-123 from the print queue of your KX-PS8100, type:

```
cancel printer-123
```

To find out a print job's job ID, use the `lpstat` command described below:

On a UNIX system running Solaris 2, use the **lpstat** command to see printer jobs in the queue.

```
lpstat -o <queue name>
```

For example, if your printer queue is named KX-PS8100q, type:

```
lpstat -o KX-PS8100q
```

The returned list of jobs includes each job ID.

Once `lpr` print jobs are spooled to the printer's hard disk, you can use WebSpooler to monitor print jobs.

Setting up IPX (Novell) printing



IPX, Novell's Internetwork Packet Exchange protocol, runs on networks that include a Novell NetWare server. The server, typically a dedicated PC, is usually configured to control workstation access to shared resources. In addition to other services, NetWare servers use IPX protocols to provide spooling, queue management, and print services to computers (including Macintosh, DOS, UNIX, and VAX) whose operating software is compatible with IPX protocols.

This section describes network setup for an IPX (Novell) network.

Overview of IPX printing to the KX-PS8100

NetWare file servers support the creation of print queues, storage areas for print jobs. When a user on a network workstation prints a job, the job is sent to a print queue on the NetWare server. The job is spooled to the NetWare file server disk, freeing up the workstation.

The queues on the NetWare server must be named to match the Direct connection and Print queue on the printer. The NetWare queue names should be given an extension corresponding to the KX-PS8100 printing connection, as follows:

```
_print  
_hold  
_direct
```

NOTE:

- The NetWare queues names must be given the above all lowercase English extension (`_print`, `_hold` or `_direct`), even if any language's NetWare server is used.

When the printer is configured to connect to a NetWare server, it polls the NetWare server for jobs in each of its queues. If jobs are found, they are transferred over the network to the matching connection: Print to Print, Direct to Direct. While a job is processed and printed, a record of the job is being created. You can access the Job Log containing these records at any time.

When the printer is connected to a NetWare print queue that is defined on the NetWare server, the printer polls the queue for jobs and receives them over the network for immediate processing and printing. All printer jobs are sent from the printer queue on the NetWare server to the printer.

NOTE:

- It is not recommended to connect printer directly to NetWare server via LPT port. It may cause unexpected print result.

To set up network printing, enable IPX/SPX Setup from the printer panel (see “Network Protocol Setup” on page 148), and set up the PServer using WebSetup after configuring the NetWare server (see “PServer Setup tab” on page 162).

Configuring the NetWare server

This section explains how to set up the NetWare server so that networked users can print to the printer from their workstations. There are two stages to this setup:

- The network administrator must set up a print queue on the NetWare server so users can print to it, and the printer can receive print jobs from it.
- Optionally, the administrator can set up the server for network installation of PostScript printer drivers on client workstations.

Before configuring a NetWare file server for printing to the KX-PS8100, make sure that it is connected to a functioning IPX network. Then, log in as the supervisor on a PC connected to the NetWare file server, and configure the file server as described in the following sections.

Before you begin, you'll need to determine the following names:

- The name of the NetWare file server on which you will define the printer as a new print server.
- The name of the NetWare print server. This name is used for communication between the printer and the NetWare file server.
- The name to assign to the KX-PS8100 Direct, Print or Hold queue. If you are defining a Hold queue, the last five characters must be `_hold`. You need to set up at least one print queue on the NetWare server for jobs that will be printed by the printer. Users will see and print to the name you assign to the Print queue.

Names should be as brief and descriptive as possible. Server names cannot begin with a period and cannot include spaces or punctuation characters other than periods.

- To complete network setup, you will need to log in to the NetWare file server and the new print server from the printer. You will need a login name and, if access to the server is restricted, a login password.

■ Setting the NetWare 4.x bindery context

Novell 4.x servers use a different environment setup than Novell 3.1x servers. (If your server is using NetWare 3.x, [proceed to “Setting up a KX-PS8100 print queue” on page 87.](#)) The native structure for Novell 4.x objects is known as Novell Directory Services (NDS). To provide backward compatibility with Novell 3.1x services, Novell 4.x servers use Bindery Emulation to “act” like a Novell 3.1x server.

To set up the NetWare 4.x server for printing to the printer, you must do the following:

- Determine the NDS path to the container in which the print server and the print queue for the printer will be created.

The container defines the bindery context for your network structure. Network devices that are not NetWare 4.x-aware need a bindery context to work with NetWare 4.x.

- Edit the network startup file to set the bindery context.
- Activate the new bindery context.

This section describes the second and third steps. Given the variety of possible network structures, we can't suggest a bindery context that applies to every network.

To set the bindery context:

- 1** At the NetWare drive prompt, change directories to the System directory, and type **rconsole**
- 2** Establish a connection with the server that will have the printer queue.
- 3** At the NetWare prompt type **load install**
The NetWare Server Installation window is displayed.

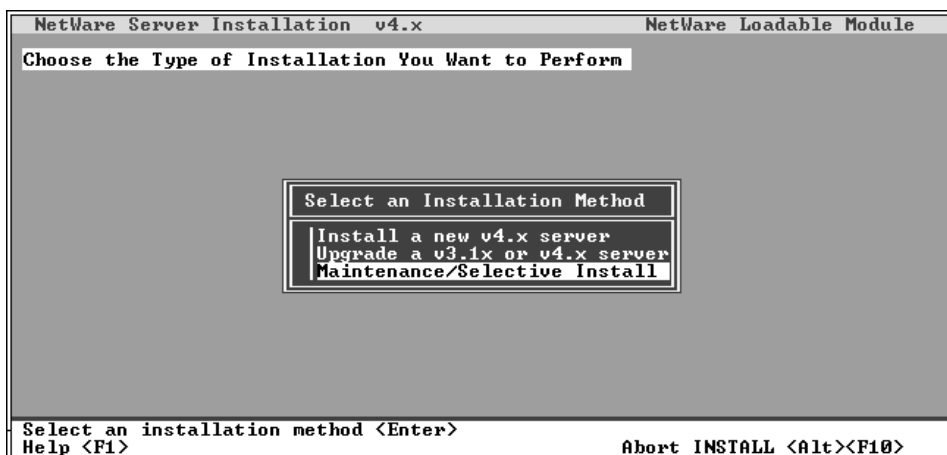

4 Use the down arrow key to select **Maintenance/ Selective Install**.

The Installation Options menu is displayed.

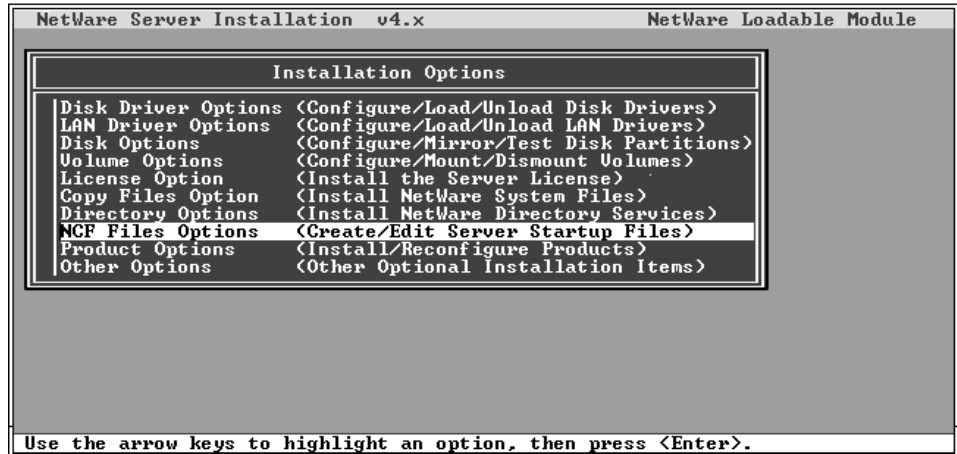

5 Select **NCF Files Options**.

6 In the menu of available NCF files, select **Edit AUTOEXEC.NCF file**.

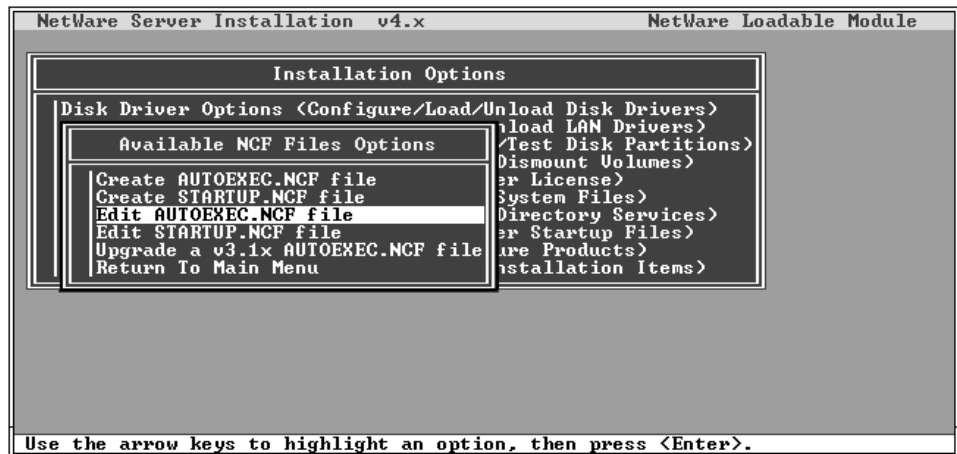

Connecting the Printer to a Network

- 7 Type a new line anywhere in the file as follows:
set Bindery Context = (Enter your bindery context here)

NOTE:

- To the right of the equals sign, type the bindery context obtained from the system administrator.

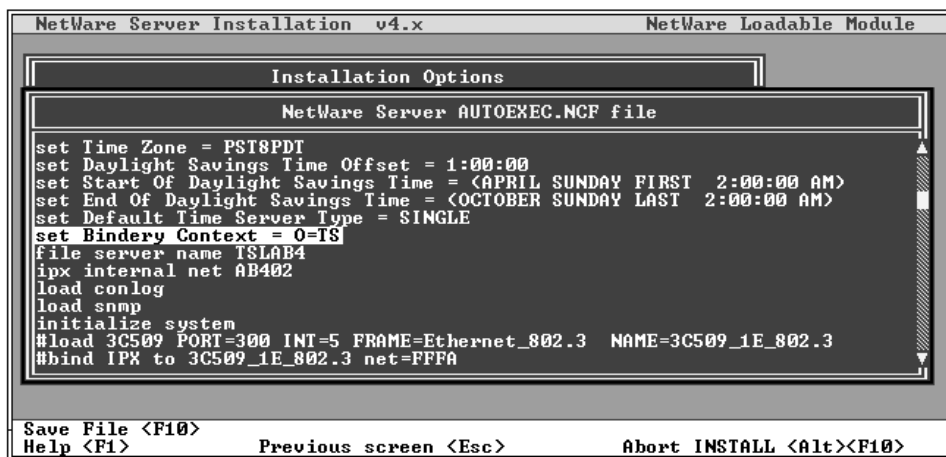

```
NetWare Server Installation v4.x                               NetWare Loadable Module
-----
Installation Options
-----
NetWare Server AUTOEXEC.NCF file
-----
set Time Zone = PST8PDT
set Daylight Savings Time Offset = 1:00:00
set Start Of Daylight Savings Time = <APRIL SUNDAY FIRST 2:00:00 AM>
set End Of Daylight Savings Time = <OCTOBER SUNDAY LAST 2:00:00 AM>
set Default Time Server Type = SINGLE
set Bindery Context = 0=IS
file server name TSLAB4
ipx internal net AB402
load conlog
load snmp
initialize system
#load 3C509 PORT=300 INT=5 FRAME=Ethernet_802.3 NAME=3C509_1E_802.3
#bind IPX to 3C509_1E_802.3 net=FFFA
-----
Save File <F10>
Help <F1>          Previous screen <Esc>          Abort INSTALL <Alt><F10>
```

- 8 Press **Esc** to close the window, and save changes.
- 9 Proceed to the next section.

To activate the bindery context:

- 1 If you cannot reboot the NetWare server at this point, type the **set** command manually at the server's command prompt.
Use the same command that you entered in the autoexec.ncf file (see [step 7](#) in the previous procedure).
- 2 If you can reboot the NetWare server, the **set** command is loaded automatically.
You are ready to set up the KX-PS8100 print server and print queue. See the next section for details.

Setting up a KX-PS8100 print queue

The NetWare print server and print queue are created and configured from NetWare Print Console, a NetWare utility that is stored in NetWare's PUBLIC directory.

To set up the NetWare server for printing to the KX-PS8100:

- 1 Log in to the NetWare server as the Supervisor.
- 2 At the NetWare MS-DOS prompt, type **pconsole**
The Available Options menu is displayed.

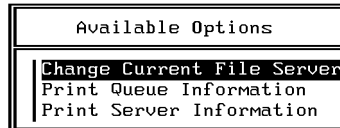

- 3 Select **Change Current File Server** and press the **Enter** key.
- 4 Using the arrow keys, select the file server name and press the **Enter** key.

File Server	User Name
ACCOUNTING	SUPERVISOR
GRAPHICS	SUPERVISOR

You must select this file server later as the NetWare File Server in WebSetup>Network Setup.

- 5 Select **Print Server Information** from the **Available Options** menu.

Connecting the Printer to a Network

- 6** Press the **Insert** key, type a name for the new print server, and press the **Enter** key. Then press the **Esc** key.

The screenshot shows a terminal window titled "Print Servers". The main menu contains the word "PARALLEL". To the right, a sub-menu titled "Available Options" is open, listing "ge Current File Server" and "t Queue Information". A dialog box is overlaid on the screen, titled "New Print Server Name:", with the text "Color_Printer" entered.

You must select this print server later as the NetWare Print Server in WebSetup>Network Setup.

- 7** Select **Print Queue Information** from the **Available Options** menu.

- 8** Press the **Insert** key and type a name for a new print queue. Press the **Enter** key.

The screenshot shows a terminal window titled "Print Queues". The main menu contains the word "PARALLELQ". To the right, a sub-menu titled "Available Options" is open, listing "ge Current File Server" and "t Queue Information". A dialog box is overlaid on the screen, titled "New Print Queue Name:", with the text "Color_Printer_print" entered.

The print queue name you entered will be highlighted in the Print Queues list.

If the print server manages more than one print queue, you'll have to select this name later in WebSetup>Network Setup.

- 9** Make sure the print queue name you created is selected in the **Print Queues** menu, and press the **Enter** key. The Print Queue Information menu is displayed.

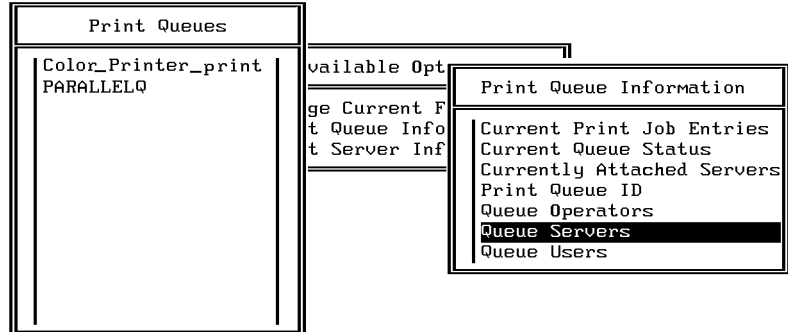

- 10** In the **Print Queue Information** menu, select **Queue Servers**, and press the **Enter** key. A blank Queue Servers list is displayed.

- 11** Press the **Insert** key. The Queue Server Candidates list is displayed.

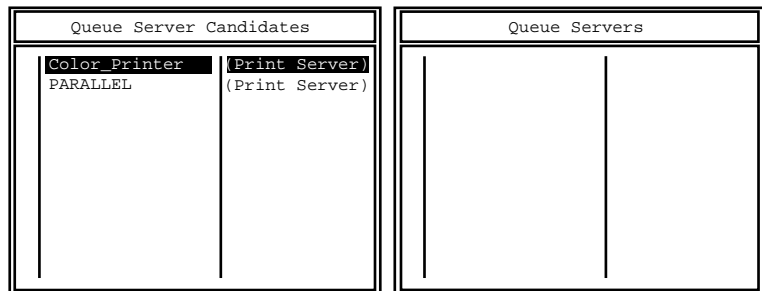

- 12** Use the arrow keys to select the name of the print server you created in [step 6](#) and press the **Enter** key. The server name you select will appear in the Queue Servers list. You have associated the selected printer queue with the print server you created in [step 6](#).

- 13** Press the **Esc** key to exit all **PCONSOLE** windows.

- 14** Select **Yes** or press the **Enter** key to save changes to **PCONSOLE**.

After finishing the above procedure, connect the specified queue server to the printer. See ["P Server Setup tab" on page 162](#).

Connecting the Printer to a Network

Setting up NetWare Windows clients

Before setting up client workstations, make sure you perform Network Setup on the printer, and that the settings reflect the entities you created in PCONSOLE.

Client setup has two parts:

- Install the PostScript printer driver on each Windows workstation.
- Configure the printer driver to print to a print queue on a Novell file server.

For instructions on installing the appropriate printer driver for your system see [Chapter 4 "Installing Software for Windows"](#).

For instructions on configuring the printer driver to print to a Novell file server print queue, see [page 98](#) for Windows 95, or [page 126](#) for Windows 3.1.

Using AppleTalk with Macintosh computers on an IPX (Novell) network

Macintosh users on an IPX network can print to the printer in two ways:

- Directly, using AppleTalk and bypassing the NetWare server
- Through a NetWare server running NetWare for Macintosh

Since the printer supports both AppleTalk and IPX protocols at the same time, it's not necessary to use the second option. However, a network administrator may choose to route all print jobs through a server.

NOTES:

- The printer can be attached to only one NetWare server at a time.
- Printing via the AppleTalk port of Windows NT 4.0 is not recommended as it may cause additional, unnecessary pages to be printed.

■ **Printing directly to the printer**

Due to the layered design of networks, data can be transmitted using more than one network protocol. When Macintosh computers are connected to an IPX network, they can continue to transmit data over Ethernet cable using AppleTalk protocols. If the printer is on the same network, Macintosh computers can see and print to the printer, provided that AppleTalk is enabled on the Macintosh and in Network Protocol Setup.

Setting up Windows 95 clients for SMB printing

The following instructions describe printing to a network port using the Details tab of the Printer Properties dialog. You must specify the option settings including Server Name in the Service Setup screen, before SMB printing is enabled. See “■ Service Setup tab” on page 166.

NOTE:

- The Details tab of the Printer Properties dialog is not available when the dialog is accessed using File>Print from within applications. This tab appears only when the Printer Properties dialog is accessed via the Printers folder.

To set up SMB printing on Windows 95:

- 1 Click **Start**, select **Settings**, and click **Printers**.
- 2 Click the **Panasonic KX-PS8100** printer icon, and select **Properties** from the **File** menu.
- 3 Click the **Details** tab in the **Properties** window and click **Add Port**.
- 4 In the **Add Port** window, click “**Network**”, and click **Browse...** to display your network environment.

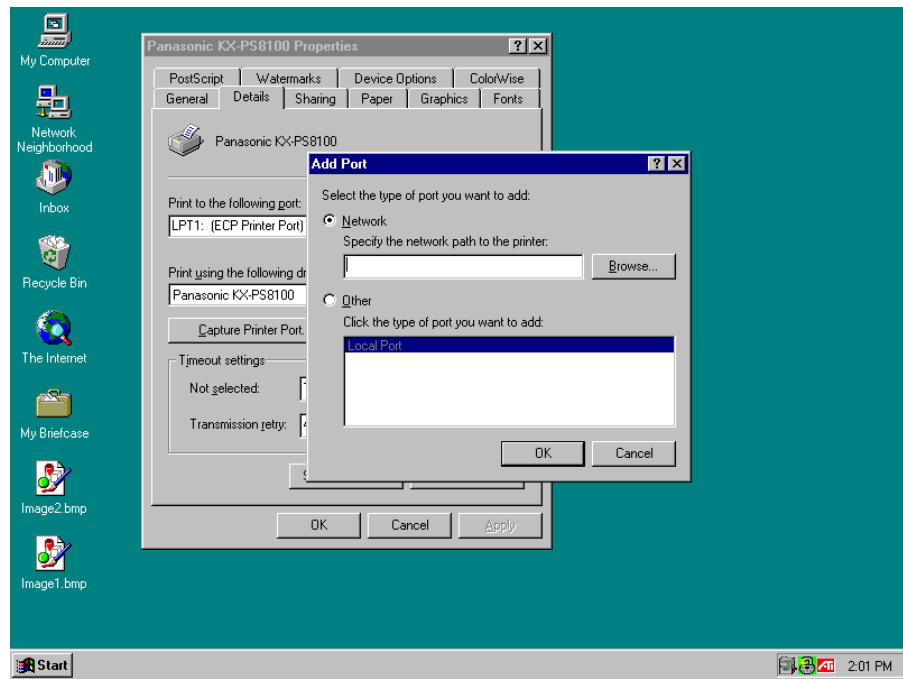

- 5 Expand the levels to locate your printer and the queue you want to print to.

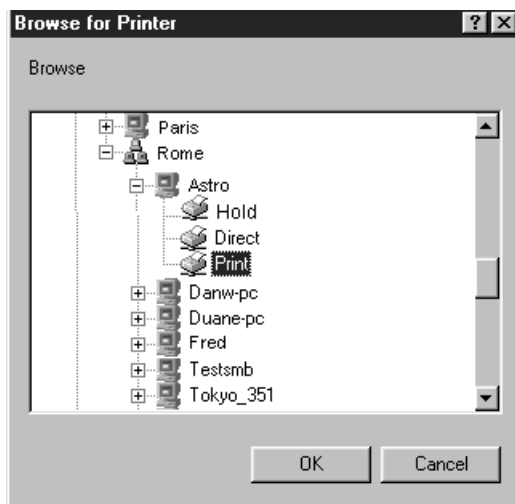

If your printer has a hard disk drive and 32 MB of memory, three connections will automatically be created when the KX-PS8100 printer driver is installed. These connections are represented on the network by the Direct, Print and Hold printer icons. If your printer does not have a hard disk drive and 32 MB of memory, only the Direct printer icon will be available.

If the Hold queue is specified, all jobs sent to the printer will be held on the printer's hard disk and will be visible in the WebSpooler window until they are printed or deleted.

The printer you are browsing for is the SMB Name Server. If you do not know the name of the SMB Name Server and SMB printing has been enabled on the printer, see the printer's Configuration page for this information.

For instructions on printing a Configuration page, see ["Printing pages from the printer panel" on page 202](#).

NOTE:

- If the local network does not include a WINS server, your printer may not be visible in the Browse window. In this case, you must type the correct path for the print connection in the "Specify the network path to the printer" box of the Add Port window, for example: \\KX-PS8100\direct.

- 6 Under the printer's name, select the queue you wish to print to and click **OK**.

- 7 In the **Add Port** window, verify that the network path is correct and click **OK**.

- 8** To confirm the connection, click the **General** tab in the **Properties** window.
- 9** Click **Print Test Page** and click **OK**.
If the test page prints successfully, you are ready to print from the computer.

Setting up Windows NT 4.0 clients for SMB printing

The following instructions describe printing to a network port using the Details tab of the Printer Properties dialog.

The Details tab of the Printer Properties dialog is not available when the dialog is accessed using File>Print from within applications. This tab appears only when the Printer Properties dialog is accessed via the Printers folder.

To set up SMB printing on Windows NT 4.0:

- 1** Click **Start**, select **Settings**, and click **Printers**.
- 2** Select the **Panasonic KX-PS8100** printer icon, and choose **Properties** from the **File** menu.
- 3** Click the **Ports** tab in the **Properties** window and click **Add Port**.
- 4** In the **Printer Ports** window, select **Local Port**, and then click **New Port**.
The Port Name window appears.
- 5** Enter the name of the printer port to print to, for example: \\KX-PS8100\direct and then click **OK**.
- 6** To confirm the connection, click the **General** tab in the **Printer Properties** window.
- 7** Click **Print Test Page** and click **OK**.
If the test page prints successfully, you are ready to print from the computer.

Chapter 4 *Installing Software for Windows*

This chapter describes installing software and setting up printing from a Windows-based computer running Windows 95, Windows 3.1, or Windows NT 4.0.

See the [Chapter 3](#) or instructions on how to connect the printer to a computer or to a network.

General steps

The general steps for installing the KX-PS8100 user software from the KX-PS8100 CD-ROMs are:

- Install the PostScript printer driver.
- Set up the printer driver to communicate with the printer over the network or through the parallel port.
- Install the scanner driver and utilities.
- Install the additional software and bundled software.

Instructions for installing the PostScript printer driver for Windows 95 and the scanner driver for Windows 95 are given below. Instructions for installing the driver for Windows 3.1 and Windows NT 4.0 systems are given later in this chapter.

If you are setting up a printer that will be shared by many users, and you would like to make the printer drivers available to others, you can exit the installer program and manually copy the printer drivers and files from the KX-PS8100 CD-ROM Disc1 to the location of your choice. Use this method, for example, to copy printer drivers to a server on your network, or to a floppy disk.

NOTE:

- Windows 95 Plug and Play specifies the automatic detection of any new hardware installed on your computer. If your printer is connected to the computer via the parallel port and it is powered on when your computer is restarted, a window indicating new hardware has been detected will appear, prompting you to install the manufacturer's software. Install the printer driver for your printer by selecting Other Location, and navigating to the PostScript printer driver directory on the KX-PS8100 CD-ROM Disc1. When you have installed the printer driver of your choice, be sure to specify optional devices installed on your printer to enable features related to their use.

Installing the software for Windows 95

Installing the PostScript printer driver for Windows 95

To set up the printer as a PostScript printer you must install the PostScript printer driver for Windows 95. This file is included on the KX-PS8100 CD-ROM Disc1.

If autorun is enabled on your computer, when the KX-PS8100 CD-ROM Disc1 is inserted in the CD-ROM drive the installer runs automatically, allowing you to specify which files to install on your computer.

NOTE:

- If autorun is not enabled, you can run the installer by double-clicking the CD-ROM drive icon in My Computer (Windows 95), or by double-clicking the Setup.exe file in the installer folder on the KX-PS8100 CD-ROM Disc1.

To install the PostScript printer driver:

- 1** Insert the **KX-PS8100 CD-ROM Disc1** in your CD-ROM drive.

The installer is launched automatically. Follow the instructions that appear on the screen.

- 2** In the **Setup Type** window, select the **Typical**, **Compact**, or **Custom** installation option.

Choose this	To install
Typical	The Adobe PostScript Printer Driver files and the KX-PS8100 PPD. Also copies the Adobe Type Manager installer (Windows 95 only), Color Reference files and Adobe PostScript 3 Fonts to your hard disk.
Compact	The Adobe PostScript Printer Driver files and PostScript 3 Fonts.
Custom	Only the files you select—copies them to your hard disk.

- 3** Follow the instructions that appear on the screen.

A message appears on the screen to indicate installation is complete.

Specifying installed devices

When the printer driver is installed, specify the optional devices installed on your printer to enable use of options relating to those devices.

To specify devices installed on the printer:

- 1 Click **Start**, select **Settings**, and click **Printers**.
- 2 Click the **Panasonic KX-PS8100** printer icon and select **Properties** from the **File** menu.
- 3 Click the **Device Options** tab, click the **Options** tab, and then specify the devices installed on the printer.

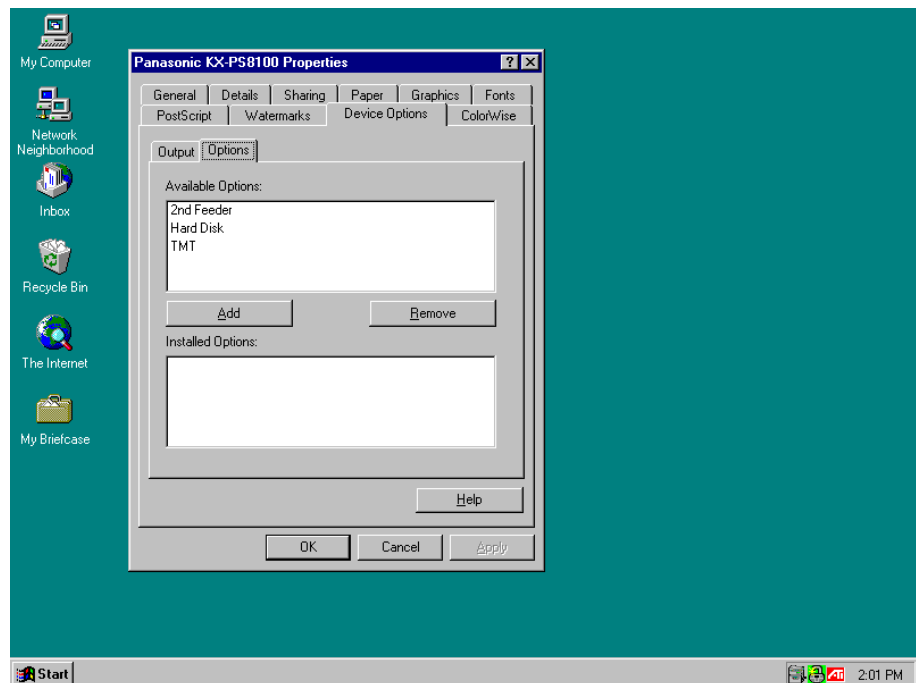

2nd Feeder—Select if an optional 500 sheet feeder is installed.

Hard Disk—Select if an optional hard disk drive is installed.

- 4 For each, select from the **Available Options** list and click **Add** to move the option to the **Installed Options** list.
 - To remove the option from the Installed Options list, click **Remove**.
- 5 Click **Apply** and **OK**.

Completing the connection for Windows 95

To print from Windows 95 you need to:

- Set up the printer to accept print jobs from your computer.
- Configure a port on each Windows 95 computer for the network or connection type.

■ Setting up parallel printing with Windows 95

The following procedure describes how to prepare the computer for parallel printing.

To install the printer for parallel printing:

- 1** Click **Start**, select **Settings**, and click **Printers**.
- 2** Click the **Panasonic KX-PS8100** printer icon and select **Properties** from the **File** menu.
- 3** Click the **Details** tab and make sure the box “Print to the following port:” reads as follows: **LPT 1 (Printer Port)** or **LPT1 (ECP Printer Port)**.
- 4** Click **Apply**.
You are now ready to print from your applications to the printer with the parallel port. To confirm the connection, print a test page.
- 5** Click the **General** tab.
- 6** Click **Print Test Page** to print a test page.

NOTES:

- When problems with printing have occurred or a test page does not print, see [“Troubleshooting” on page 234](#).
- If “timeout error” appears often, perform the following steps:
 1. Click the **Details** tab of the printer properties window, then click **Spool Settings...**
 2. Click “Print directly to the printer”.
 3. Click **OK** twice.

■ Setting up IPX (Novell) printing with Windows 95

The following procedure describes how to prepare the computer for printing using IPX protocols.

Before you begin:

Verify the printer has been configured for Novell printing in Network Protocol Setup.

For more information about setting up the printer for IPX (Novell) printing, see ["Setting up IPX \(Novell\) printing" on page 82](#).

To set up IPX (Novell) printing:

- 1** Click , select **Settings**, and click **Control Panel**.
- 2** Double-click the **Network** icon.
Make sure that IPX/SPX-compatible Protocol is listed in the Installed Network Components section. For instructions, see your Windows 95 documentation.
- 3** Close the **Network** window and the **Control Panel** window.
- 4** Click , select **Settings**, and then click **Printers**.
- 5** Click the **Panasonic KX-PS8100** printer icon, and select **Properties** from the **File** menu (or right-click the printer icon, and left-click **Properties**).
- 6** Click the **Details** tab, and click .
A list of connection options is displayed.
- 7** In the **Add Port** window, click "**Network**" and specify the network path, or click for a display of your network environment.
- 8** If you are using a NetWare file server, double-click the icon of the server you want to use for printing to the printer and click .
- 9** Click the printer icon labeled with the NetWare print queue you will use and click .

10 In the **Add Port** window, verify that the network path is updated, and click **OK**.

To confirm the connection, you can print a Windows 95 test page.

11 Click the **General** tab in the **Properties** window, and click **Print Test Page**.

You are ready to print to the printer from Windows applications. When you select Print, jobs are routed to the print queue on the NetWare file server, and then sent to the printer.

NOTE:

- If the test page is not printed, perform the following steps:
 1. Perform steps 1 and 2 to display the Network window.
 2. Double-click IPX/SPX-compatible Protocol in the Configuration tab.
 3. Click Advanced tab and select Frame Type.
 4. Set the Frame Type in WebSetup to the Frame Type displayed here (see page 162).

Installing the scanner driver and utilities for Windows 95

When a **Typical** installation is performed using the installer, following files are automatically installed.

- Digital Duplicator Utility
- Status Display
- Scanner Driver

You can also select following additional file to install during a **Custom** installation procedure.

- Print Count Manager

NOTE:

- When reinstalling the KX-PS8100 software, do it immediately after restarting Windows.

To install the bundled software (CorelDRAW Select Edition), see “Installing the bundled software” on page 133.

To install the scanner driver and utilities:

- 1** Start Windows and quit all applications.
- 2** Click **Start**, select **Settings**, and click **Control Panel**.
The Control Panel window is displayed.
- 3** Double-click the **Add/Remove Programs** icon.
The Add/Remove Program Properties window is displayed.
- 4** Click **Install...**.
The Install Program From Floppy Disk or CD-ROM window is displayed.
- 5** Insert the **KX-PS8100 CD-ROM Disc2** in your CD-ROM drive.
- 6** Click **Next>**.
The Run Installation Program window is displayed.
- 7** Click **Finish**.
The Choose Setup Language window is displayed.
- 8** Select the language, and click **OK**.
Wait until the Welcome window is displayed.
- 9** Click **Next>** after reading the window carefully.
The Setup Type window is displayed.

10 In the **Setup Type** window, select the **Typical**, **Compact**, or **Custom** installation option.

Choose this	To install
Typical /Compact	The Scanner Driver and Status Display. Also copies the Digital Duplicator Utility
Custom	Only the files you select (Print Count Manager) —copies them to your hard disk.

NOTE:

- If you want to install the Print Count Manager program, select the Custom installation option and click on () the Print Count Manager check box in the Select Components window.

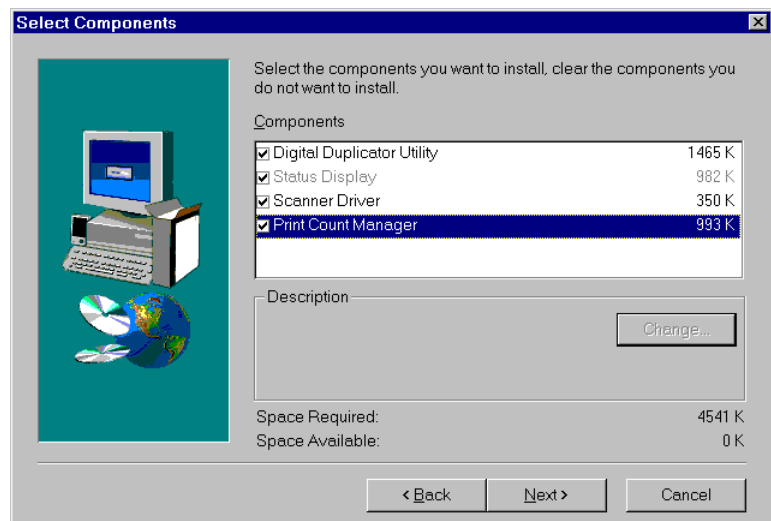

11 Follow the instructions on the screen.

A message appears on the screen to indicate installation is complete.

12 After installation, restart your system.

■ Using Plug and Play

- 1** Turn on the printer, then the scanner.
- 2** When the “**Ready**” is displayed on the printer’s LCD, turn on the computer and start Windows 95.
The New Hardware Found window is displayed for a few seconds, then the Update Device Driver Wizard window is displayed.
- 3** Insert the **KX-PS8100 CD-ROM Disc2** in your CD-ROM drive.
- 4** Click **Next>**.
- 5** Click **Other Locations...**.
The Select Other Location window is displayed.
- 6** Type “X*:\WIN32\DISK1”.
* CD-ROM drive name differs depending on your computer.
- 7** Click **OK**.
The Update Device Driver Wizard window is displayed.
- 8** Click **Finish**.
The Choose Setup Language window is displayed.
- 9** Select the language, and click **OK**.
Wait until the Welcome window is displayed.
- 10** Follow the instructions on the screen to complete the installation.
After installation, restart your system.

NOTE:

- The Plug and Play installation procedure varies depending on the version of Windows 95. Refer to Help in Windows 95.

Installing the software to Windows 98

Installing the scanner driver, utilities and PostScript printer driver

The following files will be installed by using Plug and Play.

- Scanner driver
- PostScript printer driver
- Utilities

When a **Typical** installation is performed using the installer, following files are automatically installed.

- Digital Duplicator Utility
- Status Display

You can also select following additional file to install during a **Custom** installation procedure.

- Print Count Manager

NOTE:

- When reinstalling the KX-PS8100 software, do it immediately after restarting Windows.

To install the bundled software (CorelDRAW Select Edition), see [“Installing the bundled software” on page 133](#).

NOTES:

- Before installing the software to Windows 98, make sure that the provided/not provided SCSI cable and parallel interface cable are connected properly between KX-PS8100 and your computer.
For connecting the SCSI cable, refer to step 1 to 6 (page 60 to 62).
For connecting the parallel interface cable, refer to step 1 to 3 (page 64).
- The order of installing each device depends on what is detected first.

1 Turn on the printer, then the scanner.

2 When the “Ready” is displayed on the printer’s LCD, turn on the computer and start Windows 98.

- If “Unknown Device” is displayed, go to “To install the scanner driver and utilities” (page 105).



- If “Panasonic KX-PS8100” is displayed, go to “To install the PostScript printer driver” (page 110).



To install the scanner driver and utilities:

If “Unknown Device” is displayed, the scanner driver or the utilities can be installed.

The following procedure shows the case when the scanner driver is detected first.

- 1 Click **Next>**.



- 2 Click **Next>**.



- 3 Insert the **KX-PS8100 CD-ROM Disc2** in your CD-ROM drive.
- 4 Click on () the Specify a location check box and click off the other item's check box.

- 5** Type “X*:DRIVERS\ENGLISH\WIN98\SCANNER”.
- * CD-ROM drive name differs depending on your computer.



- 6** Click **Next>**.

- 7a** If the scanner driver is not found, the following window is displayed.
- Click **<Back**, then go to step 12 to install the utilities.

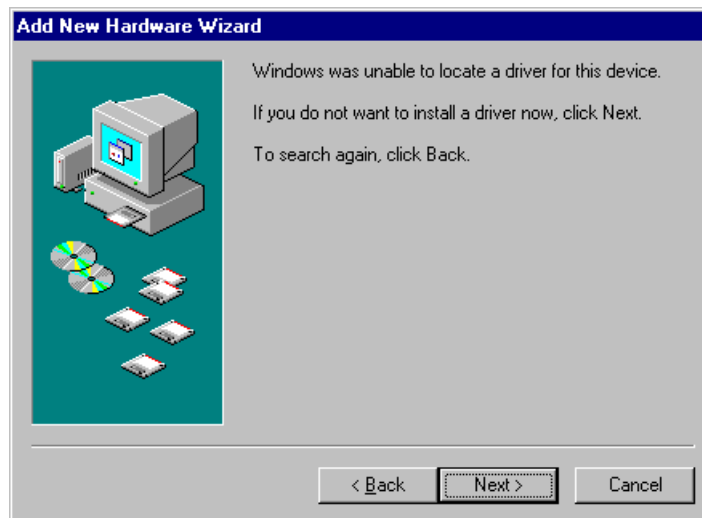

7b If the scanner driver is found, the following window is displayed.

Go to next step to install the scanner driver.



8 Click **Next>**.

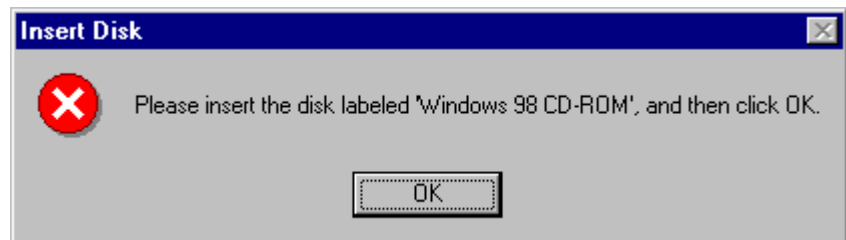

9 Click **OK**.

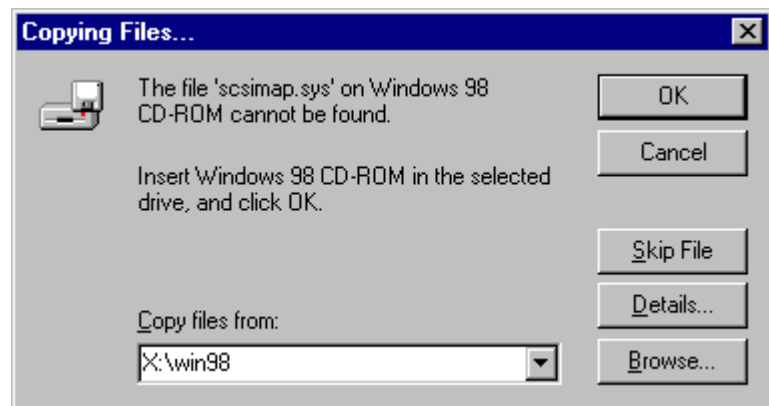

- 10** Insert Windows 98 CD-ROM, select the specific directory (win98), then click **OK**.



- 11** Click **Finish**.

- If the utilities are not installed, click **Next>** twice after clicking **Finish**. Go to step 12.
- If the scanner driver and utilities are installed and the PostScript printer driver is not installed, go to “To install the PostScript printer driver” (page 110).

- 12** Type “X*:\WIN32\DISK1”.

* CD-ROM drive name differs depending on your computer.



13 Click **Next>**.



14 Click **Next>**. The installer starts. Follow the instructions on the screen.

After copying the utility files, the “Add New Hardware Wizard” window is displayed.



15 Click **Finish**.

- If the scanner driver is not installed, go to step 1 to 11 (page 105 to 108).
- If the scanner driver and utilities are installed and the PostScript printer driver is not installed, go to “To install the PostScript printer driver” (page 110).

To install the PostScript printer driver:

1 Click **Next>**.



2 Click **Next>**.



3 Insert the **KX-PS8100 CD-ROM Disc1** in your CD-ROM drive.

4 Click on () the Specify a location check box, and click off the other item's check box.

- 5** Type “X*:\ENGLISH\PRNTDRVR\DISK1”.
- * CD-ROM drive name differs depending on your computer.



- 6** Click **Next>**.



7 Click **Next>**.

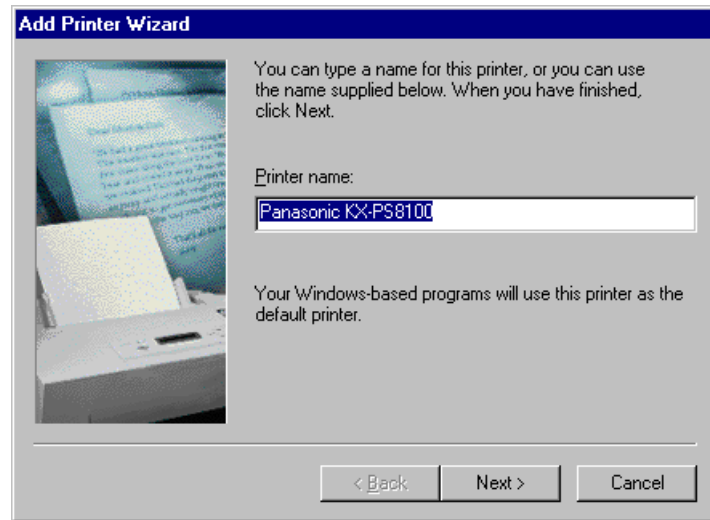

- The message in the window differs if any other printer driver is installed. Click “Yes [recommended]”.

8 Click **Next>**.

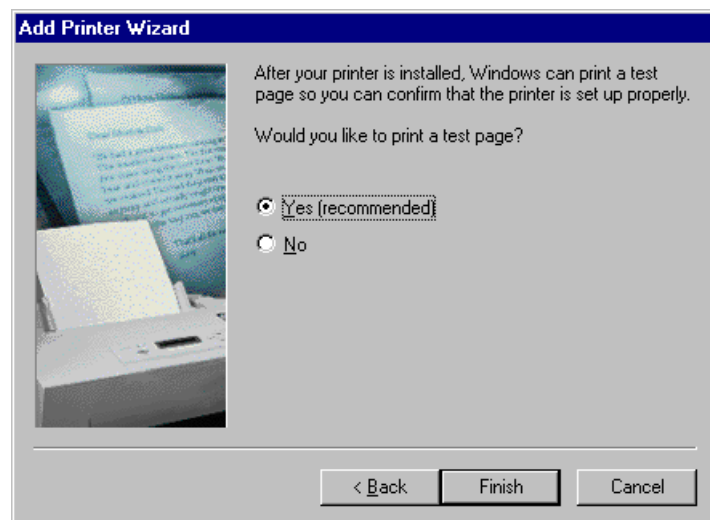

- If you do not want to print a test page, click “No”.
- If you want to print a test page, click “Yes [recommended]”.

9 Click **Finish**.



- If the scanner driver and utilities are not installed, go to “To install the scanner driver and utilities” ([page 105](#)).

Installing the software for Windows NT 4.0

Setting up PostScript printing with Windows NT 4.0

PostScript printing with Windows NT 4.0 begins with installation of the PostScript printer driver for Windows NT 4.0 and the KX-PS8100 printer PPD, and finishes by configuring a particular type of connection between the workstation and the KX-PS8100. The PostScript printer driver for Windows NT 4.0 is not included on the KX-PS8100 CD-ROM Disc1, accordingly, if the KX-PS8100 is the first PostScript printer to be used with your system, you will need to install this printer driver from your installation CD-ROM or disk for Windows NT 4.0. With this version of software, KX-PS8100 files support Intel-based Windows NT 4.0.

Adding a printer to a local system requires that you log in to your local workstation (not the network server domain) for Windows NT 4.0 and that you are a member of the Administrators group. The instructions below describe installing a printer locally. The procedure for adding a network printer is similar to adding a port. For more information, see ["■ Setting up TCP/IP and LPR printing with Windows NT 4.0" on page 118.](#)

If autorun is enabled on your computer, when the KX-PS8100 CD-ROM Disc1 is inserted in the CD-ROM drive, the installer on the KX-PS8100 CD-ROM Disc1 runs automatically, allowing you to specify the files to install on your computer.

NOTE:

- If autorun is not enabled, you can run the installer by double-clicking the CD-ROM drive icon in My Computer, or by double-clicking the Setup.exe file in the Installer folder on the KX-PS8100 CD-ROM Disc1. If optional devices are installed on your printer, follow the instructions in the next section as well.

To install the KX-PS8100 as a local PostScript printer:

- 1** Insert the **KX-PS8100 CD-ROM Disc1** in your CD-ROM drive.

The installer is launched automatically. Follow the instructions that appear on the screen.

- 2** In the **Setup Type** window, select the **Typical**, **Compact**, or **Custom** installation option.

Choose this	To install
Typical	The Adobe PostScript Printer Driver files and the KX-PS8100 PPD. Also copies the Color Reference files.
Compact	The Adobe PostScript Printer Driver files.
Custom	Only the files you select—copies them to your hard disk.

- 3** Follow the instructions that appear on the screen.

A message appears on the screen to indicate installation is complete.

Installing the PostScript printer driver for Windows NT 4.0

If this is the first PostScript printer installed on your computer and you attempt to install the KX-PS8100 PPD, the Files Needed window will appear, prompting you to locate the PostScript driver PSCRIPT.DLL for Windows NT 4.0.

To complete the installation if PostScript files are needed:

- 1** Eject the **KX-PS8100 CD-ROM Disc1** and insert the **Installation CD for Windows NT 4.0**.
- 2** In the text field, type the name of the CD-ROM drive (for example, D:\), and click **Browse...**.
- 3** Browse to the i386 (the directory containing the PostScript driver).
- 4** Click **OK**, and then click **OK** in the **Files Needed** window.

When installation is complete, the Printers window appears with an icon for the newly installed printer.

Specifying installed devices

When the printer driver is installed, specify the optional devices installed on your printer to enable use of options relating to those devices.

To specify options installed on the printer:

- 1 Click **Start**, select **Settings**, and click **Printers**.
- 2 Click the **Panasonic KX-PS8100** printer icon and select **Properties** from the **File** menu.
- 3 Click the **Device Settings** tab, and scroll down to **Installable Options**.
- 4 Configure the following options to correspond with the features installed on the printer:

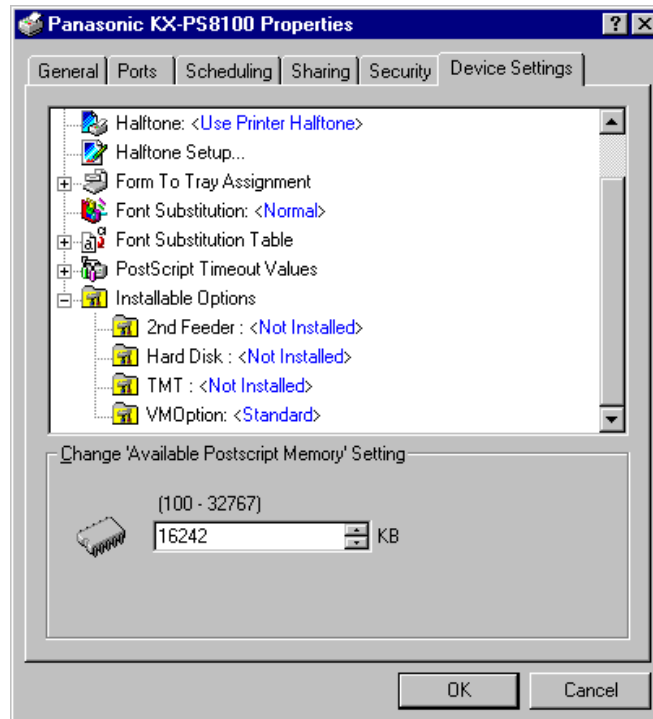

2nd Feeder—Select if an optional 500 sheet feeder is installed.

Hard Disk—Select if an optional hard disk drive is installed.

- 5 To select an option, click its name, and then select **Installed** in the **Change '...' Setting** area at the bottom of the window.
- 6 Click **OK**.

Completing the connection for Windows NT 4.0

To print from Windows NT 4.0 you need to:

- Set up network servers, if any.
- Set up the printer to accept print jobs from your computer.
- Configure a port on each computer with Windows NT 4.0 for the network or connection type.

■ Setting up parallel printing on Windows NT 4.0

Once you have installed the PostScript printer driver for Windows NT 4.0 complete the setup for parallel printing as follows:

To set up parallel printing:

- 1** Click , select **Settings**, and then click **Printers**.
- 2** Click the **Panasonic KX-PS8100** printer icon, and select **Properties** from the **File** menu.
In the Ports tab, confirm that LPT1 (Local Port) is checked. The printer is ready to accept parallel print jobs from your computer.
- 3** Click the **General** tab, and click .
When you click , your files are sent over the parallel port connection to the printer.
- 4** Click the **Sharing** tab if you want to share the printer with network users. Click "**Shared**", and enter a share name in the **Share Name** box.
Select the operating system or systems used by your network clients from the Alternate Drivers box if you want to install a printer driver that those clients can automatically download when they connect.
- 5** Click . In the window that appears, navigate to the location of the alternate printer driver to install.
- 6** Click to exit the **Printer Properties** window.

■ Setting up TCP/IP and LPR printing with Windows NT 4.0

Once you have installed the PostScript printer driver for Windows NT 4.0, complete the setup for the TCP/IP and lpr connection as follows:

- Prepare the printer to accept print jobs using TCP/IP and lpr protocols.
- Configure the workstation for the TCP/IP connection.

Before you continue, ask the system administrator for the IP address assigned to the printer and the subnet mask as well as gateway address, if they are used.

To prepare the printer for TCP/IP and LPR printing:

- 1** With the printer turned off, connect it to the network.
- 2** Turn on the printer.
Wait until "Ready" or "Ready(Sleep)" is displayed.
- 3** Press the **MENU/EXIT** button of the printer panel.
- 4** Press the **▲/CONTINUE** or **◀/Cancel** button to advance to **Network Protocol Setup** menu.
- 5** Enable TCP/IP and enter the appropriate settings for IP address, subnet mask and gateway address.
For details, see ["Network Protocol Setup" on page 148](#).
- 6** Press the **MENU/EXIT** button to exit the setup menus.

The TCP/IP Protocol and Microsoft TCP/IP Printing software should already be installed on the workstation for Windows NT 4.0. For details, see your documentation for Windows NT 4.0.

To set up TCP/IP and LPR printing for Windows NT 4.0:

- 1** Click **Start**, select **Settings**, and then click **Printers**.
- 2** Click the **Panasonic KX-PS8100** printer icon, and select **Properties** from the **File** menu (or right-click the printer icon, and left-click **Properties**).

3 Click the **Ports** tab.

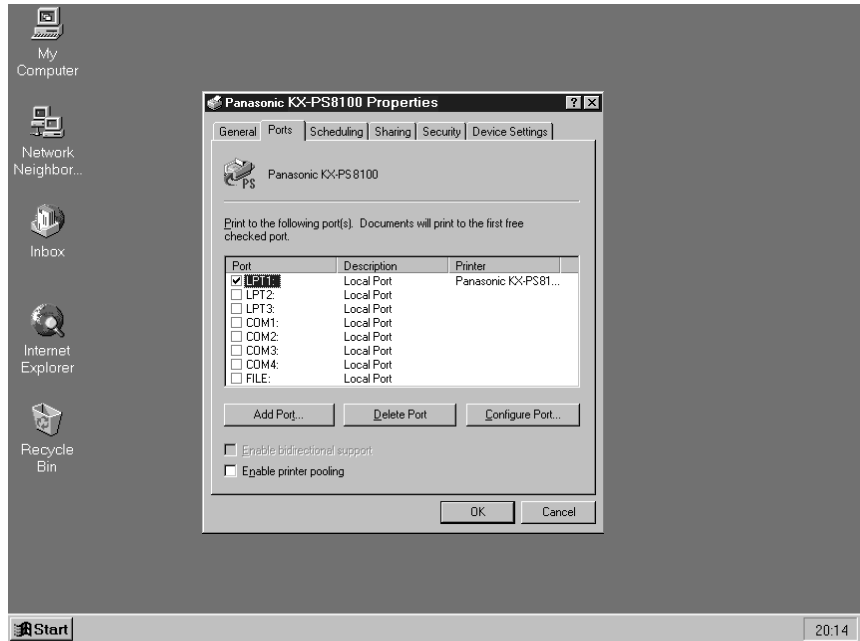

4 Click **Add Port...**.

The available port types are displayed.

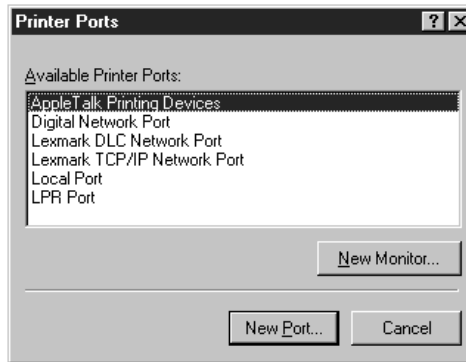

5 Select **LPR Port** and click **New Port...**.

If the LPR port is not listed, install the TCP/IP protocols and Microsoft TCP/IP Printing software. For details, see your documentation for Windows NT 4.0.

6 In the Name or address of server providing lpr box of the **Add LPR compatible printer** window, enter the IP address of the printer.

If your network uses Domain Name Services (DNS), enter the DNS name assigned to the printer instead of the IP address.

7 Press **Tab** and type the internal name of the printer in lowercase letters.

NOTES:

- Type this name exactly as shown; it is required for communication with the printer.

The name must be one of these:

xjdirect
xjhold
xjprint



- Use the last two internal names only if your printer has a hard disk drive and a minimum of 32 MB of memory.

8 Click **OK**.

The workstation checks the address or DNS name that you entered and notifies you if it cannot resolve the address.

9 Click **Close** of the **Printer Ports** window.

The Ports property tab shows the new port configuration.

10 Click **OK** to close the **Panasonic KX-PS8100 Properties** window.

The new port has been configured. You should now print a test page to verify the connection.

11 Open the **Panasonic KX-PS8100 Properties** window. Click the **General** tab and click **Print Test Page**.

When you print, your files are sent over the LPR Port connection to the printer.

12 Click **OK** to exit.

Installing the scanner driver and utilities for Windows NT 4.0

When a **Typical** installation is performed using the installer, following files are automatically installed.

- Digital Duplicator Utility
- Status Display
- Scanner Driver

You can also select following additional file to install during a **Custom** installation procedure.

- Print Count Manager

NOTE:

- When reinstalling the KX-PS8100 software, do it immediately after restarting Windows.

To install the bundled software (CorelDRAW Select Edition), see [“Installing the bundled software”](#) on page 133.

To install the scanner driver and utilities:

- 1** Start Windows and quit all applications.
- 2** Click **Start**, select **Settings**, and then click **Control Panel**.
The Control Panel window is displayed.
- 3** Double-click the **Add/Rem... Programs** icon.
The Add/Remove Programs Properties window is displayed.
- 4** Click **Install...**.
The Install Program From Floppy Disk or CD-ROM window is displayed.
- 5** Insert the **KX-PS8100 CD-ROM Disc2** in your CD-ROM drive.
- 6** Click **Next>**.
The Run Installation Program window is displayed.
- 7** Click **Finish**.
The Choose Setup Language window is displayed.
- 8** Select the language, and click **OK**.
- 9** Click **Next>** after reading the window carefully.
The Setup Type window is displayed.
- 10** In the **Setup Type** window, select the **Typical**, **Compact**, or **Custom** installation option.

Choose this	To install
Typical /Compact	The Scanner Driver and Status Display. Also copies the Digital Duplicator Utility.
Custom	Only the files you select (Print Count Manager) —copies them to your hard disk.

NOTE:

- If you want to install the Print Count Manager program, select the Custom installation option and click on () the Print Count Manager check box in the Select Components window.

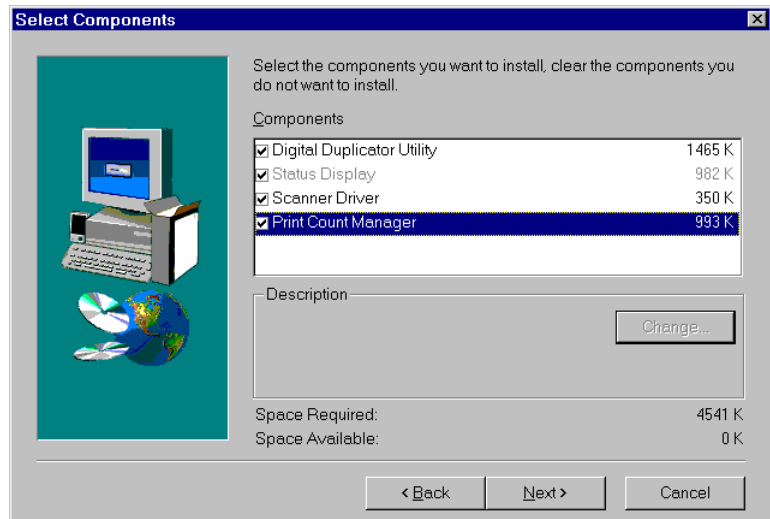

11 Follow the instructions on the screen to complete the installation.

A message appears on the screen to indicate installation is complete.

12 After installation, restart your system.

Installing the software for Windows 3.1

Installing the PostScript printer driver for Windows 3.1

The Adobe PostScript printer driver for Windows 3.1 is included on the KX-PS8100 CD-ROM Disc1.

To install the Adobe PostScript printer driver:

- 1** Start Windows and exit any applications that start automatically.
- 2** Insert the **KX-PS8100 CD-ROM Disc1** in your CD-ROM drive.
- 3** In the **Main** window, double-click the **Control Panel** icon and double-click the **Printers** icon.
- 4** In the **Printers** window, click **Add>>**, and then click **Install...**.
- 5** In the **Install Driver** window, click **Browse...**.
- 6** To install the Adobe PostScript printer driver navigate to: D*:\english\prntdrv\win3x. Click **OK**.
(* CD-ROM drive name differs depending on your computer.)
- 7** In the **Install Driver** window that appears, verify the path and click **OK**.
- 8** Select the **Panasonic KX-PS8100** from the **Add Unlisted or Updated Printer** window and click **OK**.
The necessary files are installed from the KX-PS8100 CD-ROM Disc1 to your hard disk. When installation is complete, the Panasonic KX-PS8100 on LPT1: appears in the Installed Printers list.

NOTE:

- If you fail to install the Windows 3.1 driver after the message "This driver cannot be updated because it is currently being used by Windows. Wait until Windows is finished using the driver and then try again" is displayed, remove the file `ctl3dv2.dll` under `\Windows\system` from the MS-DOS^{*1} Prompt and try to install the driver again.

^{*1} Microsoft® MS-DOS® operating system (hereafter MS-DOS)

Specifying installed devices

When the printer driver is installed, specify the optional devices installed on your printer. This will enable use of options relating to those devices.

To specify options installed on the printer:

- 1** In the **Control Panel** window, double-click the **Printers** icon.
- 2** In the **Printers** window, select the **Panasonic KX-PS8100 on LPT1:** in the **Installed Printers** list, and click **Setup...**.
- 3** In the **Panasonic KX-PS8100 on LPT1:** window, click the **Features** tab.
- 4** Specify the options that correspond to the devices installed on the printer.

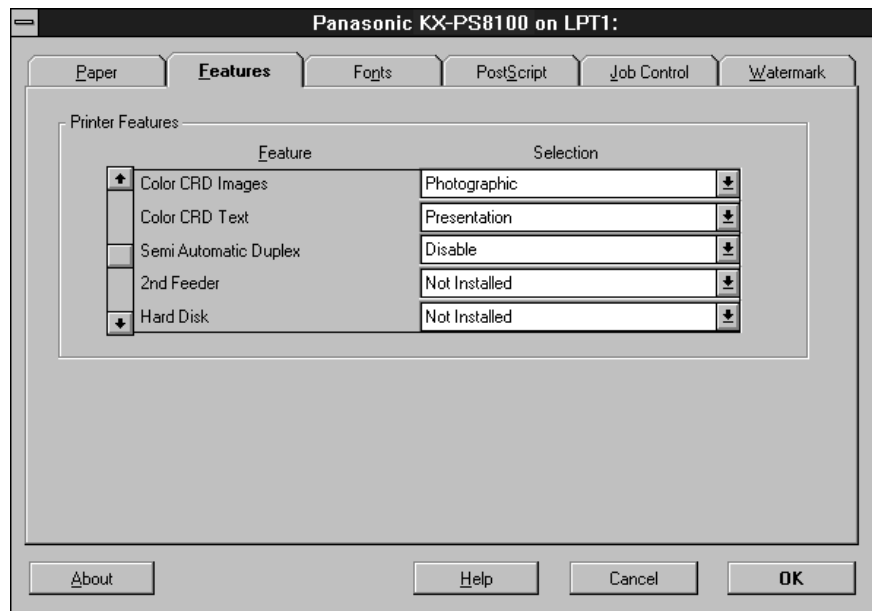

- 5** For each option installed on the printer, select **Installed** from the corresponding menu.
2nd Feeder—Select if an optional 500 sheet feeder is installed.
Hard Disk—Select if an optional hard disk drive is installed.
- 6** Click **OK** to activate the current settings.

Completing the connection for Windows 3.1

To print from Windows 3.1 you need to:

- Set up the printer to accept print jobs from your computer.
- Configure a port on each Windows 3.1 computer for the network or connection type.

■ Selecting a printer port

When you install a printer, Windows assigns it to a default parallel printer port. If the KX-PS8100 printer is connected to your computer through a network or you want to assign it to a different port, you need to change the port assignment. For information on which port to use, see your system administrator.

To select a printer port:

- 1** In the **Control Panel** window, double-click the **Printers** icon.
- 2** In the **Printers** window, select the **Panasonic KX-PS8100 on LPT1:** in the **Installed Printers** list box.
- 3** Click **Connect...**.
The Connect window appears.

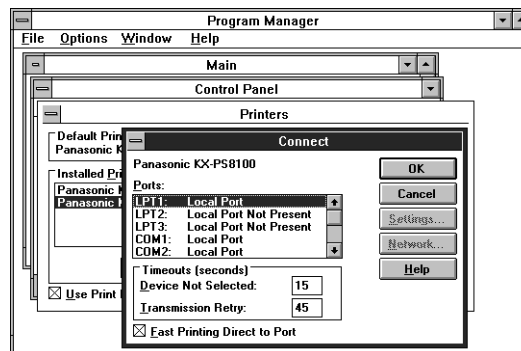

- 4** Connect the printer to the same port as your network.

To print to a file, select FILE.

Printing to a file is useful if the printer is not at your site. However, if you select the FILE port, you cannot print to a printer until you select a network or printer port. (In some applications, you can select the FILE port from the application's Print window; this is preferable for temporary use since it doesn't require resetting the port in the Control Panel.)

- 5 Click **OK**.
The Printers window appears, with the selected port next to the highlighted printer name in the Installed Printers list box.
- 6 When you are finished, click **Close**.

■ Setting up IPX (Novell) printing with Windows 3.1

The following procedure describes how to prepare the computer for printing using IPX protocols.

Before you begin:

Verify the printer has been configured for Novell printing in Network Protocol Setup.

For more information about setting up the printer for IPX (Novell) printing, see ["Setting up IPX \(Novell\) printing" on page 82](#).

To set up IPX (Novell) printing:

- 1 In the **Main** group of the **Program Manager**, double-click the **Windows Setup** icon.

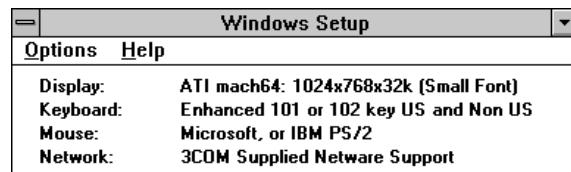

- 2 Click **Change System Settings...** from the **Options** menu.
- 3 Click **Novell NetWare (shell version 3.26 and above)** from the **Network** menu.

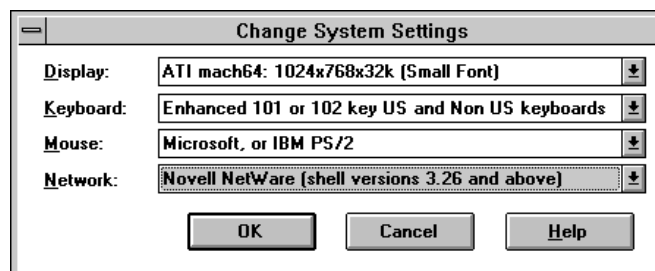

- 4** Click **OK**. When prompted, restart Windows.
- 5** In the **Control Panel** window, double-click the **Printers** icon.
- 6** In the **Printers** window, click **Connect...** to connect the printer to the appropriate port.
- 7** Click **Network...**.

If you are printing to a file, select FILE. Printing to a file is useful if the printer is not at your site. However, if you select the FILE port, you cannot print to a printer until you select a network or printer port. If you click **Network**, the next window depends on the NetWare client driver version.
- 8** If the **Network Printer Connections** window is displayed, select the port in the **Printer connections** box.
- 9** In the **Available** queues list box, select the server and queue name that correspond to the KX-PS8100.
- 10** Click **Connect**, and then click **Close**.

The Connect window is displayed with the network path to the KX-PS8100.
- 11** Click **OK** in the **Connect** window.
- 12** Click **Close** in the **Printers** window.
- 13** Click **OK**.

The Printers window appears again, with the selected port next to the highlighted printer name in the Installed Printers list box. You are ready to print from the workstation.

Installing Software for Windows

Installing the scanner driver and utilities for Windows 3.1

When a **Typical** installation is performed using the installer, following files are automatically installed.

- Digital Duplicator Utility
- Status Display
- Scanner Driver

You can also select following additional file to install during a **Custom** installation procedure.

- Print Count Manager

NOTES:

- If you are using Windows 3.1, disable or uninstall any application software's printer status to prevent conflicts with the KX-PS8100 Status Display for Windows 3.1.
- When reinstalling the KX-PS8100 software, do it immediately after restarting Windows.

To install the bundled software (CorelDRAW Select Edition), see ["Installing the bundled software" on page 133](#).

To install the scanner driver and utilities:

- 1** Start Windows and quit all applications.
- 2** Insert the **KX-PS8100 CD-ROM Disc2** in your CD-ROM drive.
- 3** Click **File** menu from the **Program Manager** window and click **Run....**
- 4** Click **Browse...** and select your CD-ROM drive from the **[Drives:]** box.
- 5** Select **setup.exe**, and click **OK**.
- 6** Click **OK**.
The installer starts. The Choose Setup Language window is displayed.
- 7** Select the language, and click **OK**.
Wait until the Welcome window is displayed.
- 8** Click **Next>** after reading the window carefully.
The Setup Type window is displayed.

9 In the **Setup Type** window, select the **Typical**, **Compact**, or **Custom** installation option.

Choose this	To install
Typical /Compact	The Scanner Driver and Status Display. Also copies the Digital Duplicator Utility.
Custom	Only the files you select (Print Count Manager) —copies them to your hard disk.

NOTE:

- If you want to install the Print Count Manager program, select the Custom installation option and click on () the Print Count Manager check box in the Select Components window.

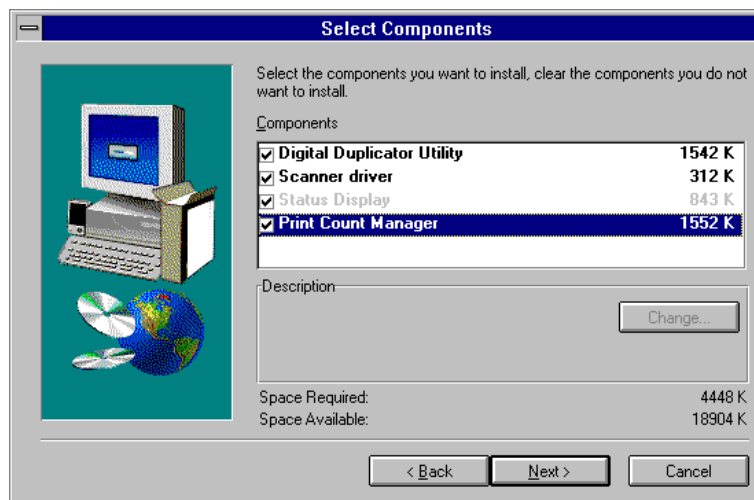

10 Follow the instructions on the screen to complete the installation.

A message appears on the screen to indicate installation is complete.

11 After installation, restart your system.

Installing additional software for Windows users

Additional software, including Adobe Type Manager (ATM), a PANTONE color reference file, a CMYK reference file, a KX-PS8100 ICM profile, is included on the KX-PS8100 CD-ROM Disc1.

When a Typical installation is performed on Windows 95 using the installer, ATM and fonts are automatically installed to a directory on your hard drive directory called Panasonic KX-PS8100. When a Compact installation is performed, only the printer drivers appropriate to your system are installed. You can also select which additional files to install during a Custom installation procedure, or you can copy the additional files from the KX-PS8100 CD-ROM Disc1 to a directory of your choice as they are needed.

NOTE:

- ATM can be installed for Windows 95 and Windows 3.1, but ATM cannot be installed for Windows NT 4.0. Windows 3.1 users must manually copy the files on the KX-PS8100 CD-ROM Disc1 to their hard drive.

Some files, such as fonts, will need to be moved to specific locations; others can be moved to a directory of your choice.

PostScript and TrueType fonts

Regular, bold, italic, and bold italic versions of PostScript Type 1 fonts, as well as TrueType fonts are provided in the PS3 Fonts folder on the KX-PS8100 CD-ROM Disc1. These fonts correspond to the PS3 fonts installed on your printer. To use these fonts in applications and to properly display them on your monitor, you will need to install them on your computer. For information on installing fonts, see the following section.

For a complete list of fonts included with the printer, see Appendix A of *Utilities and Drivers Reference Guide* on the KX-PS8100 CD-ROM Disc2.

ATM (Windows 95 and Windows 3.1)

Adobe Type Manager (ATM) is included on the KX-PS8100 CD-ROM Disc1. This application can be used to transfer PostScript Type 1 fonts to the printer's memory, or to manage fonts on the printer. You can also:

- Install the PostScript Type 1 fonts that correspond to those installed on your printer
- Print using PostScript fonts on non-PostScript printers
- Improve the screen display of PostScript fonts

When a Typical installation is performed all the files needed to install ATM for Windows 95 are copied to the KX-PS8100 directory.

To install the Type 1 fonts for Windows 95:

- 1** Click **Start** and select **Programs**, and **Adobe**, then click **Adobe Type Manager**.
- 2** Select the desired font(s) under **c:\PS3Fonts\Type1**.
- 3** Click **Add** to install them.

NOTE:

- AdobeSansXMM and AdobeSerifMM under the C:\Program Files\Panasonic KX-PS8100\Atm_95\psfonts directory cannot be installed.

To install the Type 1 fonts for Windows 3.1:

- 1** Double-click the **Main** icon of the Program Manager, and **ATM Control Panel** icon.
The ATM Control Panel window is displayed.
- 2** Click **Add...**.
- 3** Double-click CD-ROM drive **[PS3fonts]**, and then **[Type1]** in the Directories.
- 4** Select fonts you desire in the **Available Fonts** box.
- 5** Click **Add**.
- 6** Click **Exit**.

See the Help menu of ATM for information on how to use the correct version for your system.

NOTE:

- ATM cannot be used to install TrueType fonts, which are also included in the PS3 Fonts folder. These fonts can, however, be installed on Windows 95 and Windows NT 4.0 using the Control Panel > Fonts > File > Install New Font command. Windows 3.1 users can install TrueType fonts by double-clicking the Control Panel Fonts icon and selecting the fonts to be added. For additional information on installing TrueType fonts on Windows platforms, see the documentation that came with your system.

Color reference pages

CMYK and PANTONE color reference pages are provided on the KX-PS8100 CD-ROM Disc1 in the form of downloadable PostScript files.

■ CMYK color reference

The CMYK Color Reference is a PostScript file (Cmyk_ref.ps), which can be printed using a PostScript downloader utility, such as Fiery WebDownloader or from DOS prompt through parallel port by copy command (ex. copy cmyk_ref.ps prn). If the file has not already been installed in the Panasonic KX-PS8100 directory on your hard disk drive, you can copy it from the Clrfiles directory on the KX-PS8100 CD-ROM Disc1 to a directory of your choice.

Each of the 11 pages display swatches in graduated combinations of yellow, magenta, and cyan, and smaller patches that include 25%, 50%, and 75% black. The process colors are shown in 10% increments. You can specify these colors, and colors in between, in any application that allows you to define colors as CMYK percentages—and use the pages to see how they will be printed on your particular printer.

For more information about color management using the CMYK Color Reference, see “Choosing colors in PostScript applications” in *Utilities and Drivers Reference Guide* on the KX-PS8100 CD-ROM Disc2.

■ PANTONE coated color reference

The PANTONE Coated Color Reference is a PostScript file (Pantone.ps), which can be printed using a PostScript downloader utility, such as Fiery WebDownloader or from DOS prompt through parallel port by copy command (ex. copy Pantone.ps prn). If the file has not already been installed in the Panasonic KX-PS8100 directory on your hard disk drive, you can copy it from the Clrfiles directory on the KX-PS8100 CD-ROM Disc1 to a directory of your choice.

The PANTONE color matching system is a standard color system within the graphic arts and prepress industries. It specifies hundreds of spot colors, each identified with a unique number. Each PANTONE color is simulated on the printer by printing an appropriate combination of process (CMYK) colors. The ability to simulate PANTONE colors is a basic form of color management.

You can choose PANTONE colors in any application that allows you to define colors as named PANTONE colors—and use the pages to see how they will be printed on your particular printer.

For more information about color management using the PANTONE Coated Color Reference, see “Choosing colors in PostScript applications” in *Utilities and Drivers Reference Guide* on the KX-PS8100 CD-ROM Disc2.

Installing the bundled software

For Windows 95/Windows 98/Windows NT 4.0 users

- CorelDRAW Select Edition

If you are using Windows 95/Windows 98/Windows NT 4.0, when you insert CD-ROM into your drive, the bundled application installer may start automatically. If not, perform the following procedure.

To install the bundled software:

- 1** Start Windows and quit all applications.
- 2** Insert the **CorelDRAW Select Edition CD-ROM** in your CD-ROM drive.
- 3** Click **Start**, click **Run...**
- 4** Click **Browse...** and select your CD-ROM drive from the **[Look in:]** box and specific language directory. (ex, English)
- 5** Select **Setup.exe** in English folder, and click **OPEN**.
- 6** Click **OK**.
The installer starts.
- 7** Follow the instructions on the screen to complete the installation.

Removing the KX-PS8100 software

If you need to remove the KX-PS8100 software, perform the following steps.

For Windows 3.1 users

To remove the scanner driver and utilities:

- 1** From the **Program Manager**, double-click the **KX-PS8100 Utilities** icon.
- 2** Double-click the **Uninstall** icon.
- 3** Click **Yes**.
- 4** Follow the instructions that appear on the screen.

To remove the PostScript printer driver:

- 1** From the **Program Manager**, double-click the **Main** icon, **Control Panel** icon, then **Printers** icon.
- 2** Select the **Panasonic KX-PS8100 on LPTx** in the **Installed Printers** list box, then click **Remove**.
- 3** Click **Yes**.
- 4** Click **Close**.

For Windows 95/Windows 98/Windows NT 4.0 users

To remove the scanner driver and utilities:

- 1** Click **Start**, select **Programs**, and click **KX-PS8100 Utilities**.
- 2** Click **Uninstall**.
- 3** Click **Yes**.
- 4** Follow the instructions that appear on the screen.

For Windows 95/Windows NT 4.0 users

To remove the PostScript printer driver:

- 1** Click **Start**, select **Programs**, and click **Panasonic KX-PS8100**.
- 2** Click **Uninstall Panasonic KX-PS8100**.
- 3** Follow the instructions that appear on the screen.

NOTE:

- For removing the Panasonic KX-PS8100 icon in the **Printers** window, refer to Help in Windows 95/Windows NT 4.0.

To remove the Adobe Type Manager:

- 1** Click **Start**, select **Programs, Adobe**, and click **Adobe Type Manager**.
- 2** Click the **Settings** tab, and click **Uninstall ATM...**.
- 3** Click **Begin Uninstall**.
- 4** After uninstallation, restart your system.

This chapter describes installing printer and scanner driver software and setting up printing on a Macintosh computer. Instructions for setting up additional software provided on the KX-PS8100 CD-ROMs are included at the end of this chapter.

Serial port printing (LocalTalk) from Macintosh computers is not supported by the printer. For instructions on how to connect your printer to a network, [see page 70](#).

General steps for installing Macintosh software



The general steps for installing the KX-PS8100 software from the CD-ROMs and setting up printing on a Macintosh computer are:

- Enable Ethernet and AppleTalk from the printer panel
[See “Network Port Setup” on page 146](#) and [“Network Protocol Setup” on page 148](#) for details.
- Enable AppleTalk in the Chooser on the Macintosh
- Install the Adobe PostScript printer driver
- Setup the KX-PS8100 in the Chooser
- Copy font files from the KX-PS8100 CD-ROM as needed
- Install the scanner driver

NOTE:

- Initial Printer Setup, specifically, setting the printer's IP address and subnet mask, as well as its gateway (if they are used), must be performed from the printer panel. Additional options may be specified using the printer panel or Fiery WebSetup.

Installing Macintosh printing software

To set up the printer as a PostScript printer, you must install the PostScript printer description file (PPD) that corresponds to your printer and the Adobe PostScript printer driver (version 8.5.1 supports PostScript 3) provided on the KX-PS8100 CD-ROM Disc1. Printer drivers provide a way to communicate information on print jobs between your applications and the printer (and any other PostScript printer connected to your computer).

Installing the Adobe PostScript printer driver

Printer drivers provide your applications with information about your printer, such as the fonts and paper sizes available. Printer description files give you access to all printing features of the printer driver and applications. When you use the Adobe PS Printer installer, the printer description file is installed automatically.

To install the Adobe PostScript printer driver:

- 1** Insert the **KX-PS8100 CD-ROM Disc1** in your CD-ROM drive, and then double-click **KX-PS8100 Disc1** icon, the **English** folder and the **Adobe PS** folder.
- 2** Double-click the **Installer** icon.
- 3** Click **Yes** in the window that appears.
The Adobe PostScript printer driver and the PPD that corresponds to your printer are installed.
- 4** Click **Restart** in the window informing you that installation is complete.

NOTE:

- For best results any job sent to the printer should be sent using the Adobe driver and the KX-PS8100 PPD. Provide the installer to all users who send jobs.

Installing Software for Macintosh

Setting up the KX-PS8100 in the Chooser

After you install the printer driver and printer description file, you need to set up the KX-PS8100 in the Chooser. This section describes how to set up the KX-PS8100 with the Adobe PostScript printer driver.

To set up the KX-PS8100 in the Chooser:

- 1 Click the **Chooser** from **Apple (🍏)** menu and ensure **AppleTalk** is “Active”.

NOTE:

- If necessary, you may need to add the AppleTalk zone in which your printer is located.

- 2 Click the **AdobePS** printer icon in the **Chooser**.

- 3 Select the name of the KX-PS8100 from the scroll list—KX-PS8100_Direct, KX-PS8100_Print, or KX-PS8100_Hold.

NOTES:

- “KX-PS8100_Direct” is typically selected.
- If the optional hard disk drive is not installed in the printer, only KX-PS8100_Direct appears.
- The name of a printer corresponds to the system name you edited when you configured a connection to the printer. See “System Setup” on page 156.

- 4 Click **Create** or **Setup...**.

- 5 Confirm an icon appeared to the left of the printer name selected in step 3, and click **OK**.

- 6 Select the name of the KX-PS8100.

- 7 Click **Setup...**.

- 8 In the window that appears, click **Configure**.

If your printer does not have additional devices installed, skip to [step 10](#).

- 9 From the pop-up menus, specify the device options installed on your printer. Click **OK**.

This step must be completed to enable features in the printer driver relating to devices installed on the printer.

10 Close the **Chooser**.

Installing the KX-PS8100 ColorSync profile

The Adobe PostScript 8.5.1 driver can convert RGB colors of a file to a specified CMYK device target using ColorSync Color Management. The KX-PS8100 CD-ROM Disc1 includes a ColorSync profile for the KX-PS8100. This profile is optimal for color conversions for the printer.

The KX-PS8100 ColorSync profile (Panasonic KX-PS8100 ICC) and monitor profile (EFIRGB ICC) can be found in the ColorSync 2.0 directory. To install this file, drag a copy to the System Folder/Preferences/ColorSync™ Profiles folder.

NOTES:

- Printer profiles selected with ColorSync affect ColorSync™ compliant applications only.
- ColorSync version must be 2.01 or later.

To use the KX-PS8100 ColorSync printer profile:

- 1** With a document open, select **Print...** from the **File** menu.
- 2** Select **Color Matching** from the pop-up menu under the **Printer** pop-up menu.
- 3** Select **ColorSync Color Matching** or **PostScript Color Matching** from the **Print Color** pop-up menu.
- 4** Select **Panasonic KX-PS8100 ICC** from the **Printer Profile** pop-up menu.
- 5** Click **Save Settings** to save the changes to the settings.
The changes you made will be the default settings until you make additional changes and click Save Settings again.
- 6** Click **OK**.
To close the Print window, click **Cancel**.
To print a document, click **Print**.

NOTE:

- PostScript Color Matching must be specified in the Color Matching section of the Print window to enable the use of CRDs.

To use EFIRGB monitor profile:

- 1** Click the **Control Panels** from **Apple (⌘)** menu.
- 2** Select or double-click **ColorSync™ System Profile**.
- 3** Click **Set Profile...**.
- 4** Select **EFIRGB ICC** from the pop-up menu.
- 5** Click **Select**.
- 6** Close the **ColorSync System Profile** window.

Installing the scanner driver

The Panasonic KX-PS8100 Scanner Driver provides two drivers, TWAIN and a Photoshop Plug-in. The driver to be installed depends on your Macintosh application. However, TWAIN must be installed to use ColorSync adjustment function.

■ About the TWAIN scanner driver

The TWAIN driver supports image capturing at controlling the scanner within TWAIN compliant application.

A beginner can easily capture images directly from the scanner, using the application software which supports TWAIN.

A preview image is displayed through the Prescan, you can visually confirm the layout before capturing the true image.

Please read each application manual in detail to confirm whether it supports TWAIN driver or not.

The advantage of the TWAIN driver:

- If you connect the scanner to your computer using the SCSI cable, you can capture images directly from the scanner using TWAIN compliant application software such as Adobe Photoshop.
- The operation is standardized, a user experienced in TWAIN peripherals can easily capture images from the scanner.

■ About the Photoshop Plug-in scanner driver

The Photoshop Plug-in driver supports image capturing at controlling the scanner within Photoshop Plug-in compliant application.

A beginner can easily capture images directly from the scanner, using the application software which supports the Photoshop Plug-in.

A preview image is displayed through the Prescan, you can visually confirm the layout before capturing the true image.

Please read each application manual in detail to confirm whether it supports Photoshop Plug-in driver or not.

The advantage of the Photoshop Plug-in driver:

- If you connect the scanner to your computer using the SCSI cable, you can capture images directly from the scanner using Photoshop Plug-in compliant application software.
- The operation is standardized, a user experienced in Photoshop Plug-in peripherals can easily capture images from the scanner.

Using the TWAIN scanner driver

To install the TWAIN scanner driver:

- 1** Insert the **KX-PS8100 CD-ROM Disc2** in your CD-ROM drive, and double-click the **KX-PS8100 Disc2** icon.
The Panasonic Scanner Driver window is displayed.
- 2** Double-click the **English** folder.
The English window is displayed.
- 3** Double-click the **KX-PS8100 TWAIN Installer** icon.
The KX-PS8100 TWAIN Installer window is displayed.
- 4** Click **Install**.
- 5** Follow the instructions on the screen to complete the installation.

To remove the TWAIN scanner driver:

You can uninstall the TWAIN scanner driver whenever you want to.

- 1** Double-click the **System** folder.
- 2** Double-click the **Preferences** folder.
- 3** Double-click the **TWAIN** folder, and select **KX-PS8100 Scanner** and **Installer Log File**. Then drag their files and drop them onto the **Trash** icon.
- 4** Double-click the **ColorSync™ Profiles** folder in the **Preferences**.
- 5** Click the **PS8100S.ICC** file which is the Panasonic KX-PS8100 Color Scanner ColorSync™ profile. Then drag its file and drop it onto the **Trash** icon.

- 6 Select **Empty Trash...** from the **Special** menu.
- 7 Click **OK**.
Panasonic KX-PS8100 TWAIN driver will be removed from your Macintosh.

Using the Photoshop Plug-in scanner driver

To Install the Photoshop Plug-in driver:

- 1 Insert the **KX-PS8100 CD-ROM Disc2** in your CD-ROM drive and double-click the **KX-PS8100 Disc2** icon.
The Panasonic Scanner Driver window is displayed.
- 2 Double-click the **English** folder.
The English window is displayed.
- 3 Double-click the **Photoshop Plug-in** folder.
The Photoshop Plug-in window is displayed.
- 4 Drag **KX-PS8100 Scanner Plug-in** file and drop it into the **Plug-ins** folder of the Adobe Photoshop application.

NOTE:

- TWAIN must be installed to use ColorSync adjustment function.

To remove the Photoshop Plug-in scanner driver:

You can uninstall the Panasonic Photoshop Plug-in scanner driver whenever you want to.

- 1 Quit the Adobe Photoshop application at first.
- 2 Double-click the Adobe Photoshop application folder.
- 3 Double-click the **Plug-ins** folder.
- 4 Click the **KX-PS8100 Scanner Plug-in**, then drag and drop it onto the **Trash** icon.
- 5 Select **Empty Trash...** from the **Special** menu.
- 6 Click **OK**.
Panasonic KX-PS8100 Photoshop Plug-in scanner driver will be removed from your Macintosh.

Installing additional software for Macintosh users

Additional software, including Adobe Type Manager, and PostScript screen fonts are included on the KX-PS8100 CD-ROM Disc1. Copy fonts files from PS3 Fonts folder on the KX-PS8100 CD-ROM Disc1 to the System Folder of your Macintosh hard drive. Note that fonts files need to be moved to specific locations (Fonts folder of the System Folder); others can be moved to a folder of your choice.

Adobe Type Manager

Adobe Type Manager (ATM) is included on the KX-PS8100 CD-ROM Disc1. Adobe Type Manager (ATM) can be installed by using the installer in the ATM folder. This application can be used to transfer Type 1 fonts to the printer's SDRAM, or to manage fonts on the printer. You can also:

- Print using PostScript fonts on non-PostScript printers
- Improve the screen display of PostScript fonts

PostScript and TrueType fonts

In addition to PostScript Type 1 fonts, TrueType fonts are included in the PS3 Fonts folder on the KX-PS8100 CD-ROM Disc1.

ATM cannot be used to install TrueType fonts. These fonts can, however, be installed by dragging a copy of each from the PS3 Fonts folder on the KX-PS8100 CD-ROM Disc1 to your System folder.

For a complete list of fonts included with the printer, see Appendix A of the *Utilities and Drivers Reference Guide*.

Chapter 6 **Setup from the Printer Panel and WebSetup**

This chapter describes how to configure the printer's Setup options. The settings you specify in Setup determine user access to the printer, printing defaults applied to jobs, and general system settings. Some Setup options are specified during an initial Setup from the printer panel; others must be set later from Fiery WebSetup.

Initial Setup from the printer panel

Initial Setup for network printing must be performed using the printer panel. After the initial Setup is complete, you must finish configuring Setup options using Fiery WebSetup (see page 151). Some options set from the printer panel can also be modified using Fiery WebSetup.

The general steps for performing Setup from the printer panel are:

- Specify parallel port settings (page 146).
- Specify network port settings (page 146).
- Specify network protocol settings (page 148).

Before you change any Setup options, it's a good idea to print the current configuration settings, in case you need to restore these settings later. For information on printing a configuration page, see "Printing pages from the printer panel" on page 202.

Use the following procedure to access the Parallel Port Setup, Network Port Setup, and Network Protocol Setup menus from the printer panel.

To access Setup menus from the printer panel:

- 1** Turn on the printer.
Wait until "Ready" or "Ready(Sleep)" is displayed.
- 2** Press the **MENU/EXIT** button.
- 3** To advance through the options, press the **▲ /CONTINUE** button; to return to previous options, press the **◀ /CANCEL** button.
- 4** To select an option, press the **ENTER** button.
Repeat steps 3 and 4 to continue accessing other options.
- 5** To exit the **Setup** menus at any time, press the **MENU/EXIT** button.

Setup from the Printer Panel and WebSetup

Power Saver

To conserve energy and operating cost, this printer is provided with a programmable power saver feature. The printer is factory set with the power saver feature turned on to comply with ENERGY STAR® requirements. If set to On, the printer automatically turns to power saver mode when there are no print jobs received or access to the printer panel for more than 30 minutes. This mode can reduce the total power consumption of the printer to less than 35 watts. Full power mode is restored when the printer receives a job or when you press the MENU/EXIT button or print a page at the printer.

Parallel Port Setup

In addition to receiving print jobs over Ethernet or Token Ring, the printer can receive print jobs from a computer through its high-speed parallel port. If no network card is installed, the printer is connected to a computer via the parallel port.

Parallel Port Setup

To advance to the next screen, press the ENTER button.

Enable Parallel?
Yes/No [Yes*]

Press the ENTER button and select Yes to enable printing through the parallel port. Press the ENTER button.

Time out
5 to 100 [15*]

This screen appears only if Enable Parallel is set to Yes. Use this option to specify how long the printer waits without receiving data from the parallel port before deciding the current job is complete. Press the ENTER button.

Data Mode
Binary/ASCII [ASCII*] (*=Default setting)

Network Port Setup

The Network Port Setup menus allow you to specify and set up a printer port type, including: Ethernet (if optional Ethernet card is installed) or Token Ring (if optional Token Ring card is installed).

NOTES:

- Ethernet and Token Ring options appear only if an optional Ethernet or Token Ring card is installed.
- The settings do not become effective until the printer reboots or the printer is turned off and on. So if you just change the settings in Network Port Setup and do not change the settings in Network Protocol Setup, you have to turn off and on the printer.

Before you set up the printer for a Novell IPX network, be sure you have set up the Novell servers as described in [“Setting up IPX \(Novell\) printing” on page 82](#).

Network Port Setup

To advance to the next screen, press the ENTER button.

A) When the Ethernet card is installed in the printer:

Ethernet Setup

Press the ENTER button to enable advance to the Ethernet Speed screen. Press the ENTER button.

Ethernet Speed

Auto-Detect/10Mbps/100Mbps [Auto-Detect*]

Select the speed at which data can be transferred over the Ethernet network or select Auto-Detect to automatically detect the speed at which data can be transferred over the Ethernet network. In some cases, Auto-Detect may not correctly detect. If it happens, specify the correct speed in this menu or from WebSetup.

B) When the Token Ring card is installed in the printer:

Token Ring Setup

Press the ENTER button to view Token Ring network options.

NOTE:

- Token Ring options appear only if an optional Token Ring card is installed.

Token Ring Speed

Auto-Detect/4 Mbps/16 Mbps [Auto-Detect*]

Select a speed at which data can be transferred over the Token Ring network, or select Auto-Detect to automatically detect the speed at which data can be transferred over the Token Ring network.

Max. Frame Size

632/1130/2154/4202 [4202*]

Select a frame size for Token Ring communication.

Source Routing

Yes/No [No*]

Select YES to allow the packet to travel to its destination through routers on the network. The packet's source, specified using the routing options listed below, dictate the route that the packet will take. Select No for transparent (no source) routing.

(* =Default setting)

Setup from the Printer Panel and WebSetup

NOTE:

- Req. All Route and Resp. All Route are displayed only when YES is selected in Source Routing.

Req. All Route
Yes/No [No*]

If source routing is enabled, select Yes to allow all routers on the network to broadcast the presence of the printer to clients, enabling packets from clients on the network to travel to the printer by any route.

Resp. All Route
Yes/No [No*]

If source routing is enabled, and Req. All Route is set to No, select Yes to allow all routers on the network to broadcast the presence of clients to the printer, enabling packets from clients on the network to travel to the printer by any route.

(* = Default setting)

Network Protocol Setup



Network protocol setup screens are used to specify and setup TCP/IP Ethernet, TCP/IP Token Ring, AppleTalk and IPX (Novell) network protocols.

NOTE:

- When exiting Setup menus, the printer will automatically restart if changes have been made to Network Protocol settings.

Network Protocol Setup

To advance to the next screen, press the ENTER button. Select TCP/IP Setup, AppleTalk Setup, or IPX/SPX Setup, depending on your network connections.

A) When you select TCP/IP Setup:

TCP/IP Setup

Press the ENTER button to view TCP/IP options.

Enable TCP/IP?
Yes/No [No*]

Select Yes if you have a TCP/IP network connected to the printer over Ethernet cabling.

Ethernet IP Address or Token Ring IP Address
[127.000.000.001*]

Use this option to assign the printer an Ethernet or Token Ring IP address.

Setup from the Printer Panel and WebSetup

Press the ▲/CONTINUE button to increment a value. Press the ◀/CANCEL button to accept a value and move to the next number to be entered. Numbers are entered from right to left. When all values have been entered, press the ENTER button to accept your selection.

(* =Default setting)

Ethernet Subnet Mask or Token Ring Subnet Mask
[255.255.255.0*]

Use this option to specify the subnet mask for printing with TCP/IP over Ethernet or Token Ring. Press the ▲/CONTINUE button to increment a value. Press the ◀/CANCEL button to accept a value and move to the next number to be entered. Numbers are entered from right to left. When all values have been entered, press the ENTER button to accept your selection.

Use the arrow buttons to select numbers in the address. Press the ENTER button to accept your selection.

Gateway Address
[127.0.0.1*]

Use this option to specify the gateway address for printing with TCP/IP. By default, no gateway address is set. If your TCP/IP network has a gateway and you plan to print using TCP/IP, you must enter the gateway address.

(* =Default setting)

B) When you select AppleTalk Setup:

AppleTalk Setup

To advance to the next screen, press the ENTER button.

Enable AppleTalk?
Yes/No [No*]

Select YES if you have an AppleTalk network connected to the printer. Note that you can enable AppleTalk, TCP/IP, and IPX (Novell) communication simultaneously.

NOTE:

- The following option is displayed only if AppleTalk is enabled.

AppleTalk Zone

Select the AppleTalk zone in which you want the printer to appear. If you do not select a zone, the printer is assigned to the default AppleTalk zone.

(* =Default setting)

Setup from the Printer Panel and WebSetup

C) When you select IPX/SPX Setup:

IPX/SPX Setup

To advance to the next screen, press the ENTER button.

Enable IPX/SPX?

Yes/No [No*]

Select Yes if you have an IPX (Novell) network connected to the printer. Note that you can enable AppleTalk, TCP/IP, and IPX (Novell) communication simultaneously.

(* =Default setting)

Language Setup

The panel language setup menus are used to select a language for the printer panel.

Language

Press the ENTER button to view language options.

Menu Mode

English/Français/Deutsch/Español/Italiano [English*]

Select a language for the printer panel and Configuration page.

(* =Default setting)

Reset Queues

This screen appears only if an optional hard disk drive is installed. Resetting the queues clears all jobs from the Hold and Print queues, all Check and Print jobs, and the Job Log. It does not affect print option settings specified in Setup from the printer panel or from Fiery WebSetup.

Reset Queues

Yes/No [No*]

(* =Default setting)

Hard Disk

This screen appears only if an optional hard disk drive is installed. If you select Yes, all data on the hard disk drive is deleted, including jobs in the Hold and Print queues, Check and Print jobs, and the Job Log.

Format?

Yes/No [No*]

(* =Default setting)

Completing setup from Fiery WebSetup



After you have performed an initial Setup from the printer panel (see page 145), you must complete the process of configuring Setup options using Fiery WebSetup, one of the Fiery WebTools. You can also use Fiery WebSetup to remotely view and modify Setup options later.

Before you can access the Fiery WebTools, you must complete the following:

- Initial Setup, specifically, setting the printer's IP address, and subnet mask as well as its gateway from the printer panel; see page 145.
- The procedures described in "Setting up Fiery WebTools" on this page.

Setting up Fiery WebTools

Fiery WebTools allow you to manage your KX-PS8100 remotely from the Internet or from your company's intranet. The KX-PS8100 has its own home page, from which you are able to select from a variety of functions including Status, Fiery WebSpooler, WebLink, Fiery WebDownloader, and Fiery WebSetup.

IMPORTANT:

- Before you can send jobs to the printer, you must use Fiery WebSetup to complete the process of configuring Setup options, as described starting on page 154.

For information on using Fiery WebTools (other than Fiery WebSetup), see *Utilities and Drivers Reference Guide* on the KX-PS8100 CD-ROM Disc2.

In order for network users to access and use Fiery WebTools, you need to set network communication options in Network Protocol Setup on the printer panel. You also need to prepare each user's workstation to communicate with the printer using Fiery WebTools over the Internet or intranet. Once the initial Setup has been performed from the printer panel, you must complete the Setup configuration from Fiery WebSetup.

In order for client workstations to access Fiery WebTools, they must use a Web browser. The recommended browser versions are:

- Netscape Navigator 3.04 for Macintosh computers,
- Microsoft Internet Explorer 4.0.1 SP1 or Netscape Communicator 4.0.4 for Windows computers.

NOTES:

- Microsoft Internet Explorer 3.x does not support the Fiery WebDownloader.
- Netscape and Microsoft continue to release frequent updates to their browsers. As support cannot be guaranteed for all versions, use the versions specified above for best results.
- Accessing to WebSetup via Netscape Navigator 3.04 for Macintosh computers is slow and not recommended.
- It is not recommended to open WebTools at several locations simultaneously because it might adversely affect network printing.
- WebDownloader is not supported for Macintosh computers.
- If Java Applet is not set to Enable, you can not access the Fiery WebTools. Follow the next steps:

Netscape 4.x

1. Select Preferences in the Edit menu.
The Preferences window appears.
2. Select Advanced in the Category.
3. Click the boxes next to Enable Java and Enable JavaScript.
4. Click **OK**.

Netscape 3.x

1. Select Network Preferences in the Options menu.
The Preferences window appears.
2. Click the Languages tab.
3. Click the boxes next to Enable Java, and Enable JavaScript.
4. Click **OK**.

Internet Explorer 4.x

1. Select Internet Options in the View menu.
2. Click the Security tab.
3. Click the circle next to Custom (for expert users) in the Local Intranet zone.
4. Click Settings button.
The Security Settings window appears.
5. Click Custom in Java permissions, and click Java Custom Settings button.
The Local intranet zone window appears.
6. Click the Edit Permissions tab, and click Enable in Run Unsigned Content.
7. Click **OK** three times.

Setup from the Printer Panel and WebSetup

Instructions below apply to computers using Ethernet protocols.

To use Fiery WebTools on each client workstation:

- 1** Enable TCP/IP on the printer.
- 2** Make sure the workstation has a valid, unique IP address.
- 3** Make sure the workstation is installed with an Internet browser.
- 4** Launch the Internet browser.
- 5** Enter the IP address or DNS name of the printer in the browser's URL line.

The printer's home page appears. For more information on using Fiery WebTools, [see page 154](#) and "Part 3 Printer Function-Managing Print Jobs" in *Utilities and Drivers Reference Guide* on the KX-PS8100 CD-ROM Disc2.

Setup from the Printer Panel and WebSetup

Accessing Fiery WebSetup

To use the Fiery WebTools via the Internet or your site's intranet, you need an Internet browser and the IP address or DNS name of the KX-PS8100.

To access Fiery WebSetup:

- 1 Start up your Internet browser application.
- 2 Enter the IP address or the DNS name of the KX-PS8100 in the URL line of your browser.

Get the IP address or DNS name from your network administrator.



The KX-PS8100 home page appears. The individual Fiery WebTools are listed on the left. To display information about a particular tool, click the question mark next to its name.

3 Click **WebSetup**.

If a password has been set on the printer, you are prompted to enter it before you can access Fiery WebSetup.



The options that you can specify from Fiery WebSetup are grouped into three categories: System Setup, Network Setup, and Printer Setup. These are described in the following sections.

If you change a Setup option, the Cancel and Save buttons flash when you click to select another Setup category.

- Click **Save** to save a change made to a setting.
- Click **Cancel** to cancel a change.

NOTE:

- You must click either **Save** or **Cancel** before you can proceed to another Setup category or exit Fiery WebSetup.

When you have finished specifying settings from Fiery WebSetup, click **Save** to save your settings, and then close the Fiery WebSetup window.

Setup from the Printer Panel and WebSetup

System Setup

In System Setup, you specify settings from two tabs: the System Setup tab and the Password tab.

To set System Setup options:

Click the **System Setup** button.

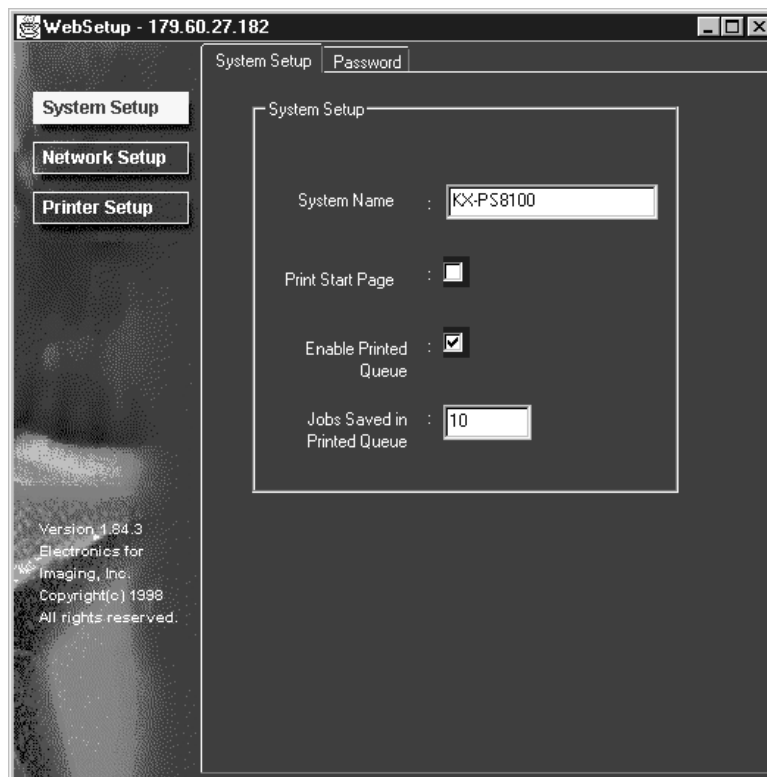

■ System Setup tab

The options that you can set from the System Setup tab are described below.

System Name—The default name of the printer appears in this text field. Edit the default name here. This is the name you should enter when you configure a connection to the printer over AppleTalk.

Print Start Page—The KX-PS8100 printer does not have Start Page. So please ignore this setting.

Enable Printed Queue—If your printer has a hard disk drive installed, select this option to create a storage location on the hard disk for the most recent print jobs. Users with Administrator privileges can use the WebSpooler to reprint jobs in the printed queue without sending those jobs to the printer again.

Jobs Saved in Printed Queue—Specify the number of jobs (from 1-99) to be saved in the Printed Queue.

■ Password tab

From the Password tab you can set an Administrator password or change the existing one. Once an Administrator password has been set, users will be prompted for this password when they attempt to access Fiery WebSetup or Fiery WebSpooler.

To set or change the Administrator password:

Click the **Password** tab.

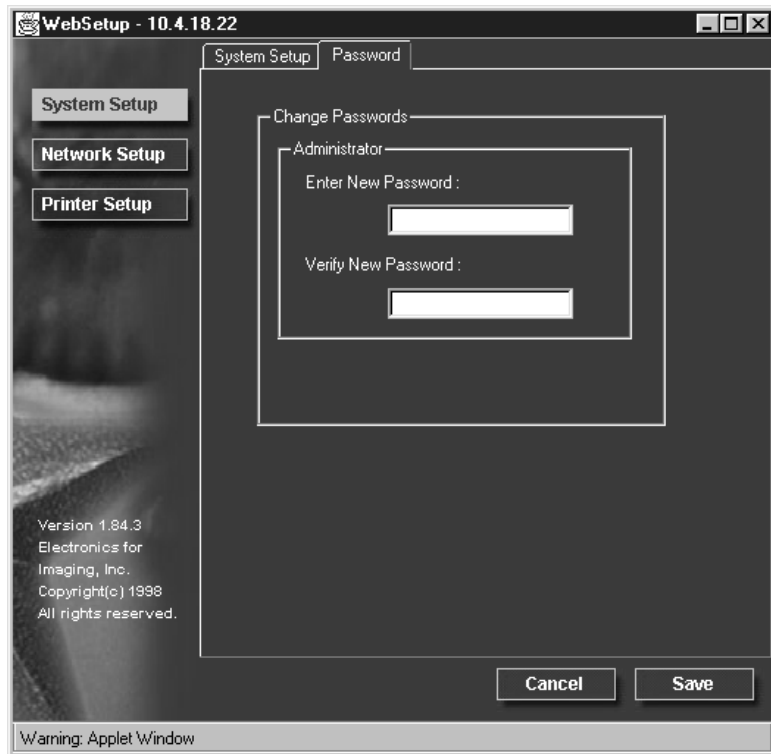

Enter New Password—To set a new password, enter a password in the Enter New Password text field.

Verify New Password—To verify a new password, enter the same password in the Verify New Password text field as you have entered in the Enter New Password text field.

NOTE:

- By default no password is set on the printer. It is recommended that a password be set to protect the printer from accidental or incorrect changes to printer Setup settings.

Setup from the Printer Panel and WebSetup

Network Setup

In Network Setup, you specify settings from four tabs: Port Setup, Protocol Setup, PServer Setup, and Service Setup.

To set Network Setup options:

Click the **Network Setup** button.

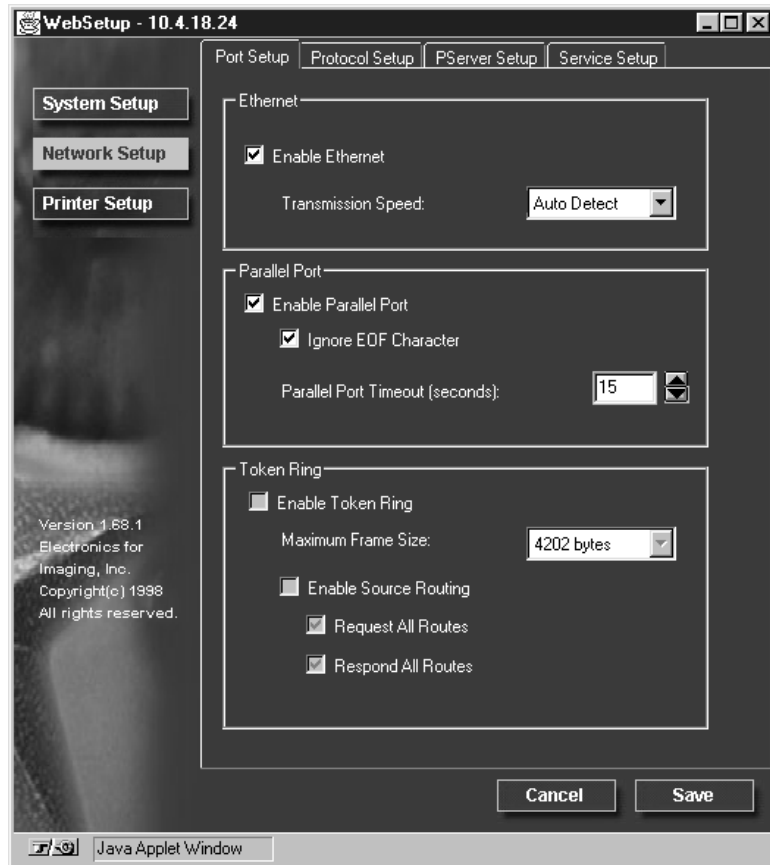

The Port Setup tab is the first tab displayed in Network Setup. You can also access Protocol Setup, PServer Setup, and Service Setup tabs from this window. After setting all the options in the Port Setup tab, click the next tab and continue to specify settings until you have made settings for all relevant options in the Network Setup category.

■ Port Setup tab

The options that you can set from the Port Setup tab are described below.

Enable Ethernet—Enable this option if the printer is to be connected to an Ethernet network.

Transmission Speed—Select Auto Detect if your network environment is mixed, or select the speed (10 Mbps or 100 Mbps) of the network to which the printer is attached.

Enable Parallel Port—Enable this option if you want to print through the parallel port. You can connect a single Windows computer to the parallel port and print directly to the printer.

NOTE:

- Enabling the parallel port does not conflict with Ethernet or Token Ring communication with the printer.

Ignore EOF Character—Available only if Enable Parallel Port is enabled, this option specifies that the printer should ignore end-of-file (EOF) messages.

Enabling this option is required to print PostScript files in binary format (not ASCII); under normal circumstances, this option should not be enabled. When this option is enabled, the printer uses the parallel port timeout value to determine when the end of the file has been reached.

Parallel Port Timeout (seconds)—Available only if Enable Parallel Port is enabled, this option's setting determines how long the printer waits without receiving data from the parallel port before deciding that the current job is complete. Until the timeout, the printer cannot receive new jobs through the parallel port, but it can continue to receive network print jobs.

Enable Token Ring—Enable this option if the printer is to be connected to a Token Ring network.

Maximum Frame Size—Select the maximum frame size recommended by the network administrator at your site. If you are uncertain of the setting to use, select the default value (4202 bytes).

Enable Source Routing—Enable this option if your network supports source routing.

Request All Routes—This option is active only if you enabled Source Routing. Enable this option if you want the Request packet to travel to its destination by all routes.

Respond All Routes—This option is active only if you did not enable the previous option (Request All Routes). Enable this option if you want the Response packet to return by all routes to the originating computer.

■ Protocol Setup tab

The options that you can set from the Protocol Setup tab are described below.

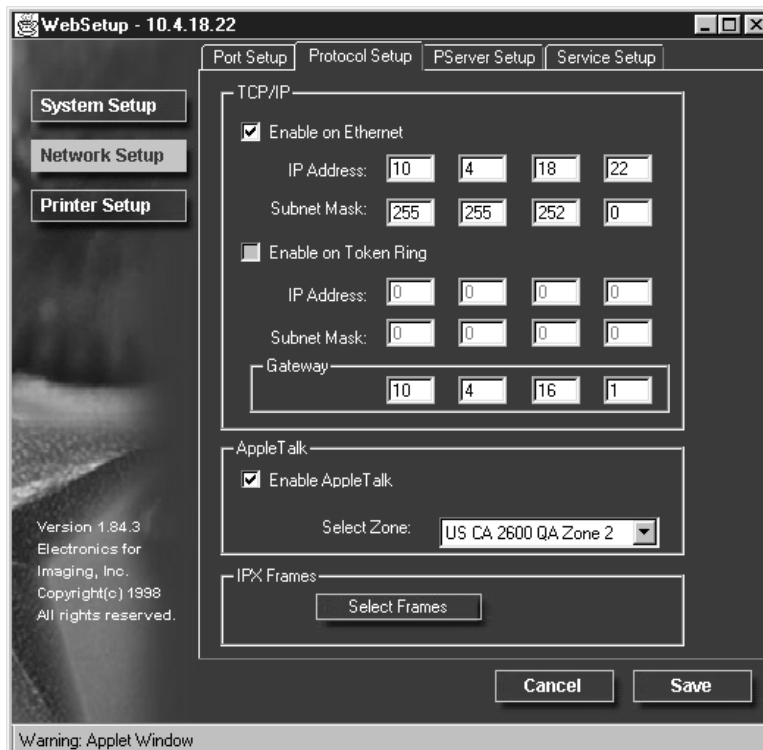

The printer can accept jobs via TCP/IP (over either Ethernet or Token Ring), AppleTalk, and IPX/SPX simultaneously. To configure the printer, choose each protocol and enter the settings for that protocol.

Enable Ethernet or, if you have enabled and installed the Token Ring option, enable Token Ring. If your network uses a gateway, enter the gateway address.

Enable on Ethernet—Enable this option if you have a TCP/IP network connected to the printer over Ethernet cabling.

You must enable TCP/IP for Ethernet to use the Fiery WebTools over Ethernet.

IP Address—Enter the KX-PS8100 IP address for Ethernet. The printer is shipped with the IP address set to the loopback address (127.0.0.1), which is an internal address used for network checking. If you plan to print with TCP/IP, you must first assign the printer a unique network IP address. For information about setting up printing with TCP/IP, see [“Connecting the Printer to a Network” on page 70](#).

Subnet Mask— If you need to set the subnet mask, enter one of the following values:

- 255.0.0.0 if the IP address starts with a number less than 128
- 255.255.0.0 if the IP address starts with a number from 128 through 191
- 255.255.255.0 if the IP address starts with a number greater than 191

Be sure to confirm the subnet mask setting with your network administrator before proceeding. In some cases the required setting may be different from those listed.

Enable on Token Ring—Enable this option if you have a TCP/IP network connected to the printer over Token Ring. If you use Token Ring, enabling TCP/IP for Token Ring is required for enabling the Fiery WebTools.

IP Address—Enter KX-PS8100 IP address for Token Ring. The printer is shipped with the IP address set to the loopback address, (127.0.0.1) which is an internal address used for network checking. If you plan to print with TCP/IP, you must first assign the printer a unique network IP address. For information about setting up printing with TCP/IP, see [“Connecting the Printer to a Network” on page 70](#).

Subnet Mask—If you need to set the subnet mask, enter one of the following values:

- 255.0.0.0 if the IP address starts with a number less than 128
- 255.255.0.0 if the IP address starts with a number from 128 through 191
- 255.255.255.0 if the IP address starts with a number greater than 191

Be sure to confirm the subnet mask setting with your network administrator before proceeding. In some cases the required setting may be different from those listed.

Gateway—If your TCP/IP network has a gateway, and users outside the gateway plan to print to the printer using TCP/IP, enter the gateway address here. By default, the loopback address, 127.0.0.1, is set. Obtain the correct gateway address from your network administrator.

Enable AppleTalk—Enable this option if you have an AppleTalk network connected to the printer. This setting enables the printer to communicate over AppleTalk networks.

Setup from the Printer Panel and WebSetup

Select Zone— The printer searches the network for AppleTalk zones in your network segment. Scroll through the list to select the AppleTalk zone in which you want the printer to appear. If your segment has only one zone, the printer is assigned to that zone automatically.

If no AppleTalk zone can be found, your network may have no defined zones, or else the network cable has not been connected (see page 70). Choose **OK**.

Select Frames—Click the Select Frames button to specify IPX frames used with NetWare. See your network administrator to verify which frame type to choose.

In the IPX Frames window, select frames and use the Add and Remove buttons to specify the selected frames.

■ PServer Setup tab

IPX (Novell NetWare) options are set in the PServer Setup tab.

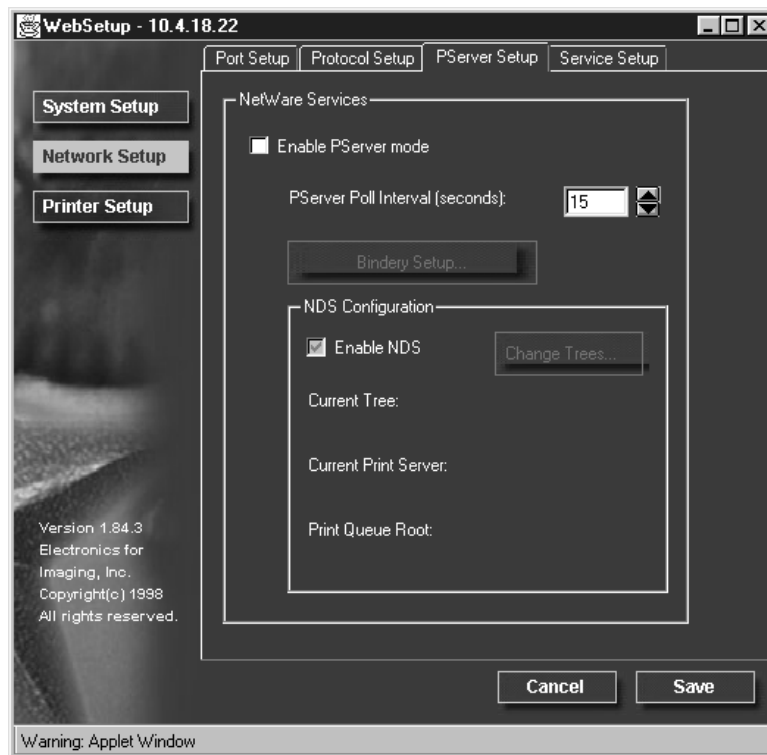

You can modify both NetWare 3.x (Bindery) and NetWare 4.x (NDS) configurations from Fiery WebSetup. Turn on the Enable NDS option if your network uses NetWare 4.x in native mode. Click Bindery Setup if your network uses NetWare 3.x or uses NetWare 4.x in bindery emulation mode.

NOTE:

- If your network uses **both** NDS and Bindery, set up NDS first. Setting up NDS after Bindery will overwrite Bindery Setup. If your network uses both NDS and Bindery, including using NetWare 4.x servers in bindery emulation, the KX-PS8100 cannot service NDS and bindery emulation servers on the same NDS tree.

PServer Setup (NetWare Services)

The Enable PServer mode option must be turned on if you have a Novell server connected. You can change the PServer Poll Interval and modify either Bindery Setup or NDS Configuration.

NOTE:

- To enable PServer mode you must first select a frame type. See “Select Frames” on page 162.

A) PServer Setup (NDS Configuration)

In initial setup, the KX-PS8100 was connected to the network and an NDS directory tree, with a Printer, a Print Server, and one or more Print Queue objects for KX-PS8100 jobs was configured (see page 87). You can make any changes to that setup through WebSetup. To modify NDS Setup you may need permission to browse the NDS tree. If access to the Print Server is restricted, you'll need a login password.

Note that the terms NetWare server, Novell server, and IPX server are in common use and are used here interchangeably to mean the server on an IPX network running Novell NetWare networking software.

To set up the NDS configuration:

- 1** Check the **Enable NDS** check box.
NDS has already been enabled. Uncheck this box only to remove NDS support.
- 2** Click **Change Trees** to open the **Add NDS Tree** window.
You can have only one NDS tree, so the following process is required to change trees.
- 3** Select the current NDS tree and click **Remove**.

- 4** Select the new NDS tree and click **Add**.
Your new NDS tree selection automatically overwrites any previous tree selection. If you change the NDS tree selection and there are also current Bindery settings, you are alerted that they will be deleted. If you continue with NDS Setup, you can replace Bindery settings afterwards. To exit NDS Setup, choose **Cancel**.
- 5** Click **OK**.
The Select login user window appears.
- 6** Select the User Login object from the display in the **Select Login User** window.
- 7** Enter a password if necessary.
- 8** Click **Next**.
The Select Print Server window appears.
- 9** Select the print server from the display in the **Select Print Server** window.
- 10** Enter a password if necessary.
- 11** Click **OK**.
The Select Print Queue root window appears.
- 12** Select the print queue root from the display in the **Select Print Queue Root** window.
- 13** Enter a password if necessary.
- 14** Click **Finish**.
The NDS Configuration window reappears, showing the new settings.
- 15** Click **OK**.
You return to WebSetup window.
- 16** Click **Save**.

B) PServer Setup (Bindery Setup)

Use Bindery Setup if you have already configured one or more bindery servers (file servers running NetWare 3.x or NetWare 4.x in bindery emulation) with a Print Server and a Print Queue for KX-PS8100 jobs (see page 87). Before entering bindery settings, be sure the KX-PS8100 is connected to the network and the NetWare file server is running. You'll need a login name, and, if access to the file server or print server is restricted, you'll need a login password.

NOTE:

- The terms NetWare server, Novell server, and IPX file server are in common use and are used here interchangeably to mean the server on an IPX network running Novell NetWare networking software.

Because you can set up more than one Novell server to handle KX-PS8100 print jobs, Bindery Setup allows you to add or delete new file server connections and view the connections you have selected.

To set up the Bindery Setup:

- 1** Click the **Bindery Setup** button to display the **Add Connections** window.
The Novell Setup window appears.
- 2** Click the server you want to add.
- 3** Click **Add**.
The Add Server window appears.
- 4** Enter your user name and password.
- 5** Click **Next**.
The Add Server window shows a list of print servers you can add.
- 6** Select a print server from the list on the left.
- 7** Enter a password if a password is required.
- 8** Click **Finish**.
You return to the main Novell Setup window.
The print server you selected in the step 6 appears.
- 9** Click **OK**.
You return to WebSetup window.

10 Click **Save**.

■ Service Setup tab

The Service Setup tab is used to set Windows Printing Service options. Windows Printing Service enables the Microsoft SMB protocol, which supports peer-to-peer printing, also known as Windows (WINS) or SMB printing.

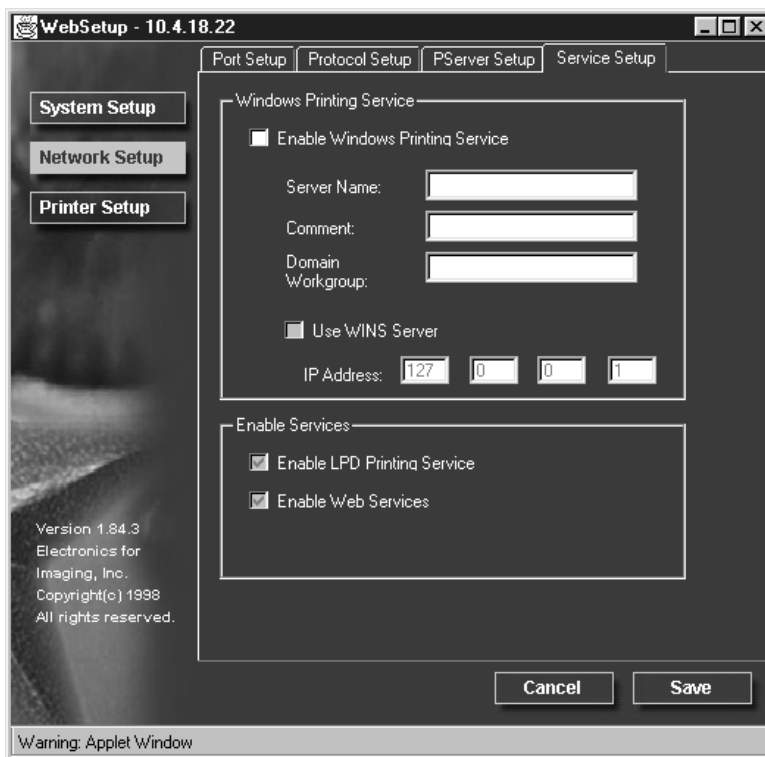

Enable Windows Printing Service— Enable this option to enable SMB (Server Message Block), the file and printer sharing protocol built into Windows. Enabling SMB allows the KX-PS8100 to be listed on the network so that Windows clients can print to a particular print connection (Hold, Print, or Direct) on the KX-PS8100 without any other networking software. For information on how to set up a Windows client for Windows printing, [see pages 91 and 93](#).

Windows (SMB) printing runs over TCP/IP, so TCP/IP must be configured on all the KX-PS8100 and on workstations that use Windows printing.

Server Name—The server name is the name that will appear on the network.

NOTES:

- Lowercase characters are not allowed.
- Each printer should have a different server name, if several KX-PS8100 printers are connected to the same network.

Comment—Server comments (optional) can contain information about the printer.

Domain Workgroup—Enter the workgroup or domain you want the KX-PS8100 to appear in.

NOTE:

- Lowercase characters are not allowed to enter.

Use WINS Server—Select to use a WINS name server. Broadcasts from SMB devices cannot be routed beyond their original network segment without a WINS name server. Setting up the WINS name server is outside the scope of this manual. To find out if a name server is available, contact your network administrator.

IP Address—Enter the IP address of the WINS Server.

NOTE:

- The Enable LPD Printing Service and Enable Web Services options are not in effect for the KX-PS8100.

Setup from the Printer Panel and WebSetup

Printer Setup

In Printer Setup, you specify PostScript printing option settings from the PS Setup tab.

To set PostScript printing options:

Click the **Printer Setup** Button.

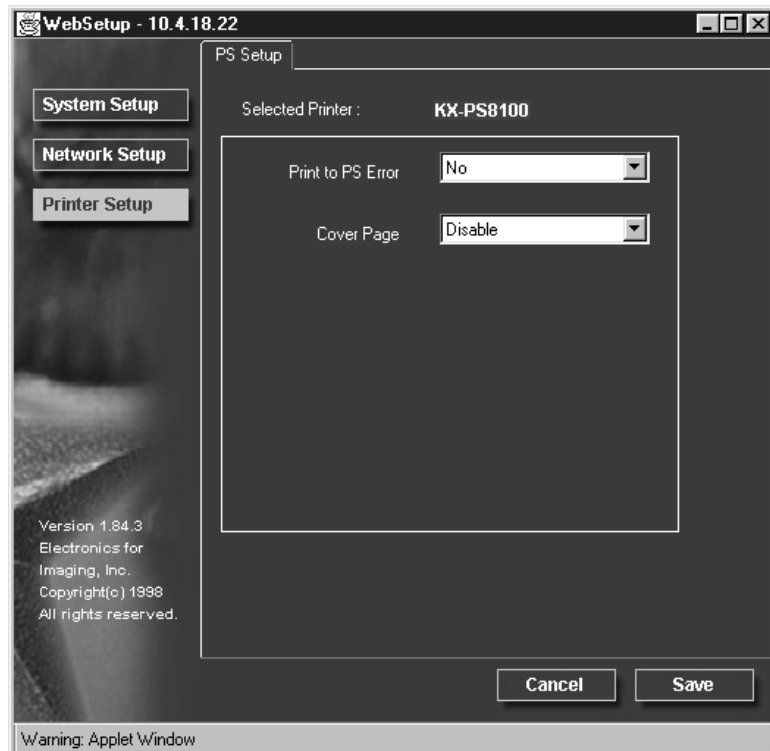

■ PS Setup tab

The options that you can set from the PS Setup tab are described below.

Print to PS Error—Specify whether the KX-PS8100 should print the available portion of a print job when it encounters a PostScript error. Select Yes to print an extra page with PostScript error messages. Select No to cancel the job entirely whenever a PostScript error is encountered.

NOTE:

- In some cases, the extra page may be printed even when No is selected.

Cover Page—Specify whether the KX-PS8100 prints a cover (job summary) page at the end of each print job. If you select Yes, each print job is followed by a page containing the name of the user who sent the job, the document name, the server name, the time the job was printed, the number of pages printed, and the status of the job. If a PostScript error occurs, and the Print to PS Error option is set to Yes, an error message takes the place of the job status.

NOTE:

- Some information may not be printed depending on the operating system on which a job is printed.

Saving your settings and exiting Fiery WebSetup

When you have finished specifying settings from Fiery WebSetup, click Save, and then close the Fiery WebSetup window by clicking the X in the top-right corner of the window. The Reboot window appears, and you are asked whether to reboot the computer or not. Select Yes to reboot the printer and initialize the new settings.

Output from color print devices is subject to changes in temperature and humidity, and is prone to drift over time, with a resulting loss in color predictability. Where color accuracy and consistency are crucial, regular calibration of the KX-PS8100 is necessary. The color output of your KX-PS8100 color printer is adjusted using three different methods: Bias Adjustment, VisualCal, and ColorWise Color Adjustment.

- **Bias Adjustment**

Used to adjust the overall color density. The overall density is changed slightly as the number of printed pages increases. If you think color output has become too dark or too bright compared to previously printed pages, perform the Bias Adjustment.

It is also recommended that you perform the Bias Adjustment after replacing the color imaging unit and/or the toner cartridge(s).

- **VisualCal**

Used to optimize the printer's range of color density and to adjust gray balance. If you think the gray color in a printed image does not appear to be a pure gray, perform the VisualCal after performing the Bias Adjustment.

- **Color Adjustment**

Used to adjust the overall brightness of color output and saturation of each color. Perform the Color Adjustment after the Bias Adjustment and VisualCal calibration to adjust color output to your preference.

The following sections describe how to use these methods to adjust the color production of your printer.

Bias adjustment

The printer's Bias Adjustment feature provides basic control over the printer's color production. The Bias Adjustment screens, accessible via the printer panel, allow you to override the printer's current toner density and brightness settings.

Using the Bias Adjustment and calibration offset controls, you can increase or decrease the density of cyan, magenta, yellow or black, and increase or decrease the overall brightness of all toner colors.

To perform Bias Adjustment:

1. Print a color calibration page to confirm the current Bias Adjustment. (See below.)
2. Compare the color calibration page with the provided Color Calibration Card. (See page 173.)
3. Perform Bias Adjustment. (See page 174.)

NOTE:

- Visual Calibration and Color Adjustment settings may affect the settings of Bias Adjustment.
 - Reset VisualCal before performing the Bias Adjustment. (See page 182.)
 - Restore the settings in Color Adjustment to the default values (all 0) before using the Bias Adjustment. (See page 185.)

To print a color calibration page:

- 1** Press the **MENU/EXIT** button on the printer panel.
“Test Page” is displayed in the printer LCD panel.
- 2** Press the **▲/CONTINUE** button.
 - Press twice if your printer has an optional hard disk drive.“Bias Adjustment” is displayed in the printer LCD panel.
- 3** Press the **ENTER** button.
“Calibration Offset” is displayed in the printer LCD panel.
- 4** Press the **▲/CONTINUE** button 5 times.
“Calibration Test Print” is displayed in the printer LCD panel.
- 5** Press the **ENTER** button.
A Color Calibration Page will be printed. (See page 172.)

Color Calibration

The current density setting for each color is indicated by the line enclosure on the Color Calibration Page.

Color Calibration Page:

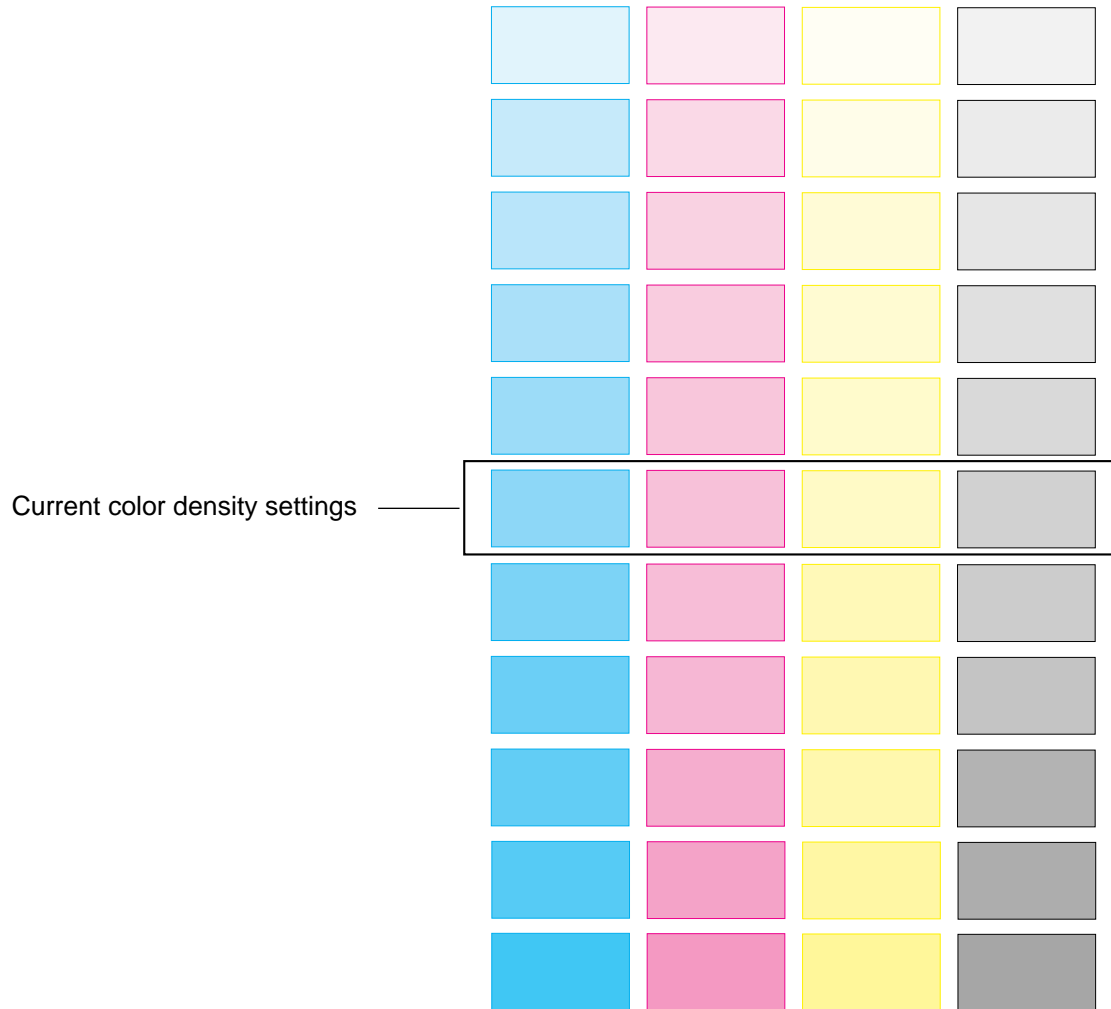

To compare current setting with the color density samples:

- 1 Compare the current color density settings on the Color Calibration Page with the color density samples on the Color Calibration Card to see if they match.

Place the Color Calibration Page on at least 2 sheets of clean white paper in a well-lighted area.

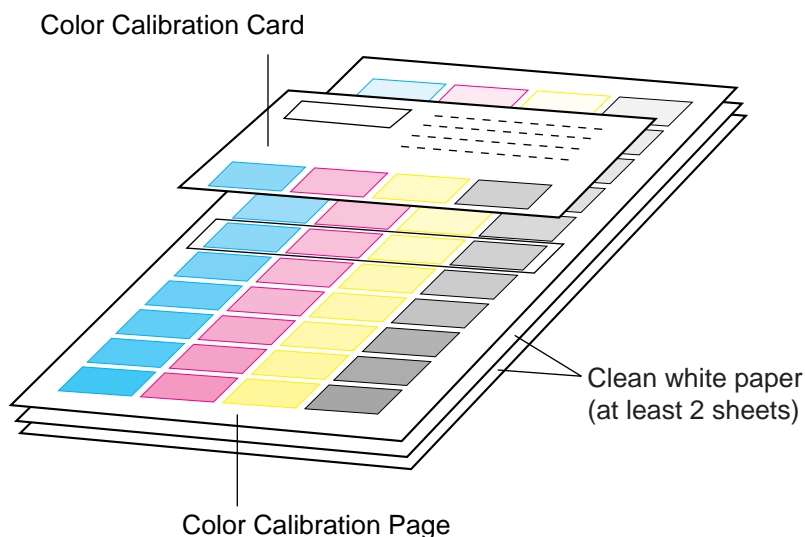

- If they match, then you do not need to adjust the color density and you may proceed with any operation you wish to perform.
- If they do not match, proceed to “To perform Bias Adjustment:” on page 174.

- 2 Determine which block on the Color Calibration Page most closely matches the density of the cyan sample on the Color Calibration Card.

Repeat step 2 for each color.

To perform Bias Adjustment:

1a If you wish to adjust the density for all colors simultaneously, perform the following, then go to [step 2](#).

1) Repeat steps 1 through 3 in [“To print a color calibration page:” on page 171](#).

“Calibration Offset” is displayed in the printer LCD panel.

2) Press the **ENTER** button.

“0*” (–5 to 5) is displayed in the printer LCD panel.

3) Press the **▲/CONTINUE** or **◀/CANCEL** button to darken/lighten all the colors.

To make the color density setting of the Color Calibration Page darker or lighter by 1 level, increase or decrease a value of the Calibration Offset by 3 by pressing the **▲/CONTINUE** or **◀/CANCEL** button.

For example when Calibration Offset is 0:

- If you wish to make the density setting darker by 1 level:
—Select 3 by pressing the **▲/CONTINUE** button 3 times.
- If you wish to make the density setting lighter by 1 level:
—Select –3 by pressing the **◀/CANCEL** button 3 times.

4) Press the **ENTER** button.

“CYAN” is displayed in the printer LCD panel.

5) Press the **▲/CONTINUE** button 4 times.

“Calibration Test Print” is displayed in the printer LCD panel.

1b If you wish to adjust the density for each color independently, perform the following, then go to [step 2](#).

1) Repeat steps 1 through 3 in [“To print a color calibration page”](#).

2) Press the **▲/CONTINUE** button.

“CYAN” is displayed in the printer LCD panel.

3) Press the **ENTER** button.

“0*” (–10 to 10) is displayed in the printer LCD panel.

- 4) Press the **▲/CONTINUE** or **◀/CANCEL** button to darken/lighten the cyan color.

To make the color density setting of the Color Calibration Page darker or lighter by 1 level, increase or decrease a value of the CYAN density by 3 by pressing the **▲/CONTINUE** or **◀/CANCEL** button.

For example when the CYAN density is 0:

- If you wish to make the density setting darker by 1 level:
—Select 3 by pressing the **▲/CONTINUE** button 3 times.
- If you wish to make the density setting lighter by 1 level:
—Select -3 by pressing the **◀/CANCEL** button 3 times.

- 5) Press the **ENTER** button.

“MAGENTA” is displayed in the printer LCD panel.

- 6) Repeat steps 3) through 5) for each color (MAGENTA, YELLOW, BLACK).

- To skip a color, press the **▲/CONTINUE** button.
- To return to a previous color, press the **◀/CANCEL** button.
- Before going to step 2, make sure the following is displayed.
“Calibration Test Print” is displayed in the printer LCD panel.

2 Press the **ENTER** button to reprint the Color Calibration Page.

- The line enclosure reflects the changes made to the settings.
- If you are not satisfied with the current color density settings, repeat the steps above.

NOTES:

- Changes made using Bias Adjustment are retained until the printer is recalibrated.
- The color density setting affects the average life of toner.
- Save the Color Calibration Card for future calibrations.

VisualCal, 30% match calibration

VisualCal™ is a calibration method that allows you to calibrate your printer to an ideal color output standard.

The calibration calculations performed by the controller software are based on a series of values entered through the printer panel. The values used in the calculations are determined by evaluating toner densities and color combinations produced on two specially designed calibration pages printed from the printer panel.

The first VisualCal page, Limits, 30% Match, provides the basis for calculating the most acceptable luminosity (brightness) of the toners. This page contains rows of CMYK dots in a graduated range of toner densities.

The variables needed to recalculate the **density** of the colored toners are determined by identifying the leftmost dots that can be fully distinguished against their fields in each row, and sequentially entering their corresponding numeric values via the printer panel. The variable needed to recalculate the **luminosity** of the toners is determined in a slightly different way- the user is required to identify the black dot which best matches a 30% dot gain field. When all values have been entered, the printer's toner density and luminosity settings are recalculated.

The second VisualCal page, Gray Balance, provides the basis for calculating a neutral gray balance, that is, a CMY gray that as closely as possible matches a pure K (Black) gray produced by the printer's engine. This page consists of rows of CMY gray patches on a field of gray produced solely from black. The variables needed to calculate the printer's most neutral gray balance are determined by identifying the CMY patch that best matches this field, and entering its row and column location on the printer panel. When the values have been entered, the printer's gray balance is recalculated.

NOTES:

- Print the Gray Balance page before the Limits calculations are made, so the gray field on which the CMY patches appear (on the Limits page) reflect the new density and luminosity calibration settings.
- VisualCal/Color Adjustment
 1. You cannot perform VisualCal or Color Adjustment if the printer displays error or warning messages. If you encounter error messages, be sure to troubleshoot them in advance.
 2. If you unintentionally enter an incorrect value during VisualCal calibration, you may see poor color output.

Calibrating the printer using VisualCal

The following procedure outlines how to calibrate the printer using VisualCal.

To perform VisualCal calibration:

- 1 From **Ready** or **Ready(Sleep)**, press the **MENU/EXIT** button and then press the **▲/CONTINUE** button repeatedly to advance to the **Visual Calibration** menu. Press the **ENTER** button.
- 2 When the screen displays **Endpoint Page** on the first line and **Print** on the second line, press the **ENTER** button.

Wait for the VisualCal Limits and 30% Match page to be printed. You will use this page to reset the printer's toner density and luminosity settings.

VisualCal™

Limits and 30% Match

PURPOSE:
The limits you select are used by the printer to adjust highlights, shadows, and contrasts to compensate for normal print engine fluctuations.

HOW TO USE THIS PAGE:
For each row, pick a circle and enter its number on the control panel.
For startpoints and endpoints:
Locate the leftmost circle you can distinguish from its background.

For best visibility, view the page at an angle under normal lighting conditions. Position the page over several sheets of white paper.

For 30% match (bottom row):
Locate the circle that best matches the surrounding gray tone.

Holding the page at arm's length, or even further away, makes it easier to choose the best match.

ADDITIONAL INFORMATION:
Values should fall between 1 and 8.
If you cannot see any circle in a given row, enter 9.
If you see circles in every column, enter 0.
If your answers are out of range, VisualCal regenerates a test pattern closer to your specific printer response.
If values are still out of range, reset the printer default color values. If that does not help, your printer may require maintenance.

Print: 1

	0	1	2	3	4	5	6	7	8	9
Black Start:	○	○	○	○	○	○	○	○	○	○
Black End:	○	○	○	○	○	○	○	○	○	○
Cyan Start:	○	○	○	○	○	○	○	○	○	○
Cyan End:	○	○	○	○	○	○	○	○	○	○
Magenta Start:	○	○	○	○	○	○	○	○	○	○
Magenta End:	○	○	○	○	○	○	○	○	○	○
Yellow Start:	○	○	○	○	○	○	○	○	○	○
Yellow End:	○	○	○	○	○	○	○	○	○	○
30% Match:	○	○	○	○	○	○	○	○	○	○

VisualCal Limits and 30% Match page

177

3 When the screen displays **Black Low**, begin the process of specifying **Low** and **High** values for each of the four toner colors, and a value for the 30% Match.

Follow the instructions provided on the Limits and 30% Match page.

For startpoints and endpoints:

—Locate the leftmost circle you can distinguish from its background.

For best visibility, view the page at an angle under normal lighting conditions. Position the page over several sheets of white paper.

For 30% match (bottom row):

—Locate the circle that best matches the surrounding gray tone.

Holding the page at arm's length, or even further away, makes it easier to choose the best match.

Note that the term **Low** displayed on the printer panel corresponds to the term **Start** on the Limits and 30% Match page; for example, to enter the **Black Low** value, check the **Black Start** row on the Limits and 30% Match page.

Use the ◀/CANCEL button or the ▶/CONTINUE button to access lower or higher values (numbers). Accept a value by pressing the ENTER button.

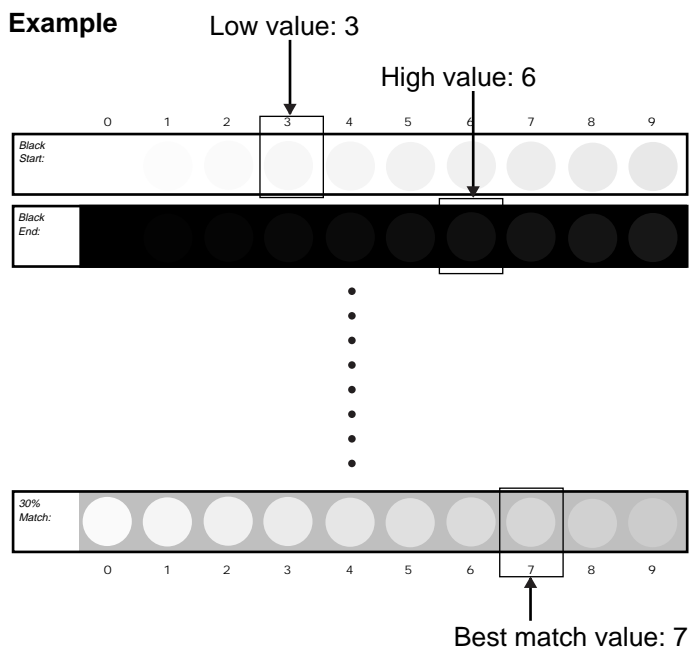

VisualCal Limits and 30% Match page

NOTE:

- Zero (0) and 9 are unacceptable values for color calibration. If any of the entered values for any colors are 0 or 9, the Limits and 30% Match page is reprinted automatically. Reenter values for all color rows starting with Black Start (Black Low).

When you have finished entering all values, the Gray Balance Page menu appears.

4 To print the **Gray Balance** page, press the **ENTER** button.

The Gray Balance page is printed and Best Patch (row) appears.

VisualCal™
Gray Balance

PURPOSE:
The gray patch you select is used by the printer to balance all colors.

HOW TO USE THIS PAGE:
Locate the color patch that best matches the gray that surrounds all the patches.
For the selected patch, enter a single row and then a single column on the control panel.
Enter 0 for row value when finished.
Select a patch in the "All" column (far right) to change only the lightness or darkness.

ADDITIONAL INFORMATION:
The background gray is printed with pure black toner only. All the other patches are printed with CMY toners.
The color and gray values on this page are affected by the "Limits and 30% Match" calibration, which should be performed first.
If this page is reprinted, the previously chosen value becomes the new "Current Gray Balance" value.
On an ideal, perfectly calibrated printer, the "Current Gray Balance" strip matches the surrounding gray color.

Print:1

	R	Y	G	C	B	M	All
-4							
-3							
-2							
-1							
0	CURRENT GRAY BALANCE CALIBRATION OF YOUR PRINTER						
+1							
+2							
+3							
+4							

Try to match this gray →

VisualCal Gray Balance page

179

- 5** Select the row number of the most acceptable patch. Use the **◀/CANCEL** button or the **▲/CONTINUE** button to select a value (+4 to -4). Accept a value by pressing the **ENTER** button. (See the example below.)

Best Patch (col) appears.

- 6** Select the column number (R.Y.G...) of the most acceptable patch. Use the **◀/CANCEL** button or the **▲/CONTINUE** button to select the column. Accept a value by pressing the **ENTER** button. (See the example below.)

The new Gray Balance page is printed. Best Patch (row) menu appears. If the new gray balance setting is acceptable, press the **ENTER** button. The Color Test menu appears. If it is not acceptable, repeat the steps 5 and 6.

Example for selecting the most acceptable patch:

Row=+4 Column=Y

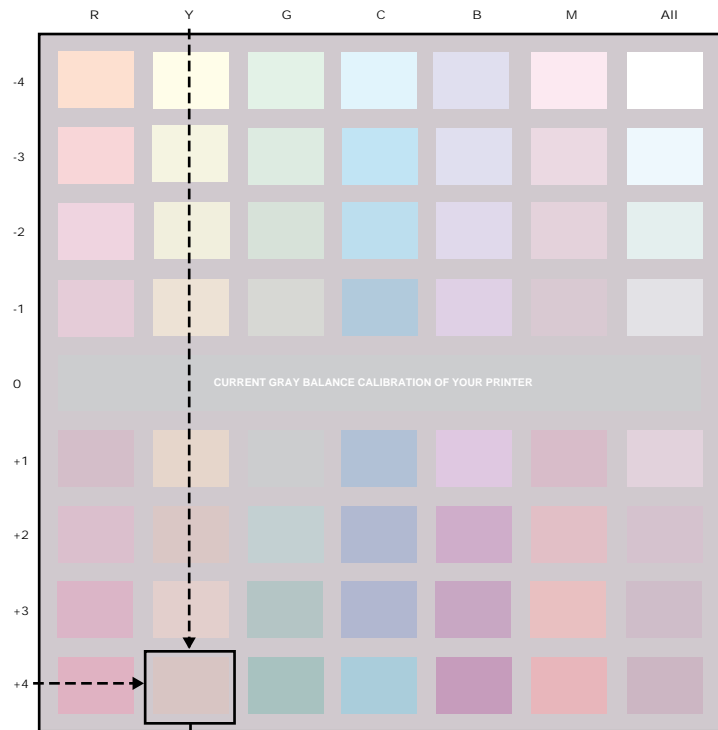

Most acceptable patch
Row: +4
Column: Y

7 To print a **Color Test** that uses the original values and a **Color Test** that uses the new values, press the **ENTER** button.



Calibration: Before

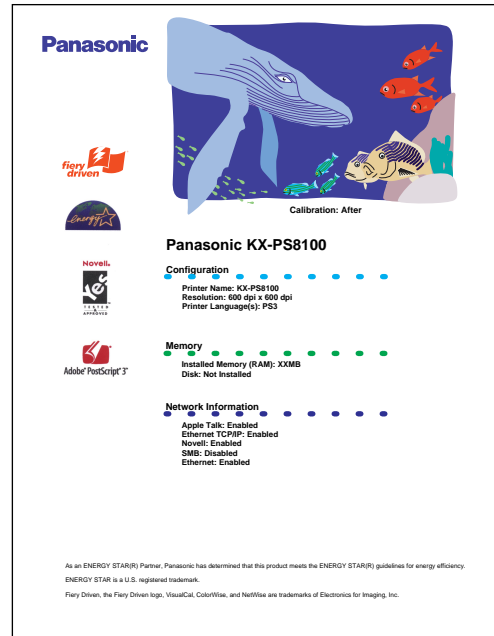

Calibration: After

NOTE:

- You can skip printing Color Test page by selecting Skip.

Before applying the calibration changes compare the Color Test that uses the original calibration values against the Color Test that uses the new values. If you are satisfied with the printer's calibration based on the new values, select Yes from the Apply Changes screen that appears, and press the ENTER button to recalibrate the printer based on the previously entered values. If you are not satisfied with the printer's calibration based on the new values, select No from the Apply Changes screen that appears. Or if you want to reset the calibration, select Default.

Resetting the VisualCal calibration

To reset VisualCal calibration:

- 1** From **Ready** or **Ready(Sleep)**, press the **MENU/EXIT** button and then press the **▲/CONTINUE** button repeatedly to advance to the **Visual Calibration** menu. Press the **ENTER** button.
- 2** When the screen displays **Endpoint Page** on the first line and **Print** on the second line, press the **ENTER** button.
Wait for the VisualCal Limits and 30% Match page to be printed.
- 3** For the **Black Low** menu and **Black High** menu, press the **ENTER** button each. For the subsequent menus: Cyan, Magenta, Yellow, 30% Match, press the **ENTER** button.
The Gray Balance Page menu appears.
- 4** Use the **◀/CANCEL** button or the **▲/CONTINUE** button to select **Skip** menu, and press the **ENTER** button.
The Color Test menu appears.
- 5** Use the **◀/CANCEL** button or the **▲/CONTINUE** button to select **Skip** menu, and press **ENTER** button.
The Apply Changes menu appears.
- 6** Use the **◀/CANCEL** button or the **▲/CONTINUE** button to select **Default** menu, and press **ENTER** button.
The Ready menu appears.

Color adjustment

The printer's color adjustment feature provides additional creative control over printer's color production. The color adjustment screens, accessible via the printer panel, allow you to override the printer's current toner density and brightness settings.

Using the color adjustment controls, you can also increase or decrease the brightness of an image, or you can increase or decrease the density of each the following colors: red, yellow, green, cyan, blue or magenta.

For example, you may choose to make the blues in an image look surreal by increasing the density of the blue and the cyan in the image, and increasing the brightness setting.

NOTE:

- You can adjust only one color at a time.

To perform color adjustment:

- 1** From **Ready** or **Ready(Sleep)**, press the **MENU/EXIT** button and then press the **▲/CONTINUE** button repeatedly to advance to the Color Adjustment screen. Press the **ENTER** button twice.
The Brightness menu appears.
- 2** Use the **◀/CANCEL** button or the **▲/CONTINUE** button to select a value*¹ (+5 to -5) that will increase or decrease in the overall brightness of printed documents. Press the **ENTER** button twice.
The Adjust Color menu appears.
- 3** Use the **◀/CANCEL** button or the **▲/CONTINUE** button to select a color to be adjusted, and press the **ENTER** button.
- 4** Use the **◀/CANCEL** button or the **▲/CONTINUE** button to select a value*² (+5 to -5) that will increase or decrease in the density of the color to be adjusted. Press the **ENTER** button twice.

The Color Test menu appears.

*¹ Negative values are darker, positive values are lighter.

*² Negative values are lighter, positive values are darker.

5 To print a **Color Test** that uses the new values, press the **ENTER** button.

Color Adjust Test pages that use the previous value and the new values are printed.

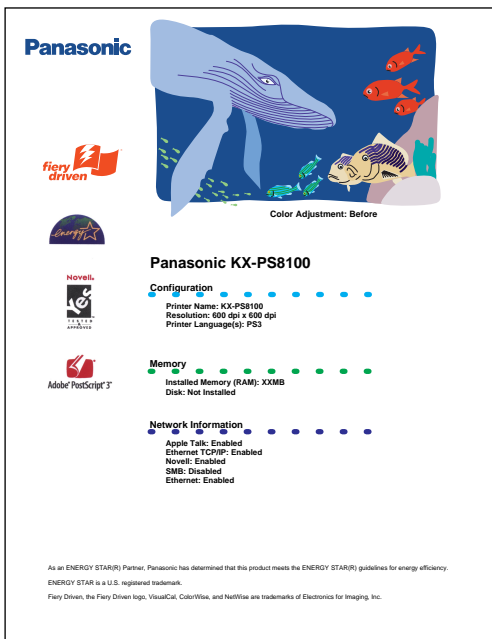

Color Adjustment: Before

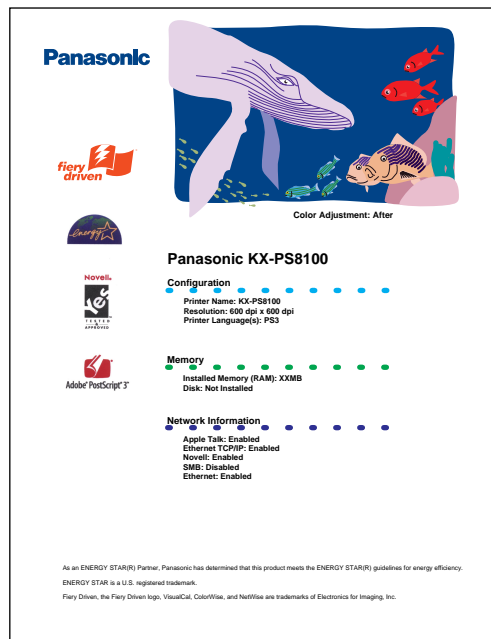

Color Adjustment: After

6 Press the **ENTER** button.

The Apply Changes menu appears.

7 To apply the new color and brightness values use the **◀/CANCEL** button or the **▲/CONTINUE** button to select **Yes**. Press the **ENTER** button.

NOTE:

- Changes made using Color Adjustment are retained until the printer is recalibrated. Or reset the adjusted colors to the last calibration made using the Reset All to 0 option in the Adjust Color screen; or recalibrate the printer using VisualCal.

**Resetting the
color
adjustment**

To reset color adjustment:

- 1** From **Ready** or **Ready(Sleep)**, press the **MENU** button and then press the **▲/CONTINUE** button repeatedly to advance to the Color Adjustment screen.
- 2** Press the **ENTER** button twice.
The Brightness menu appears.
- 3** Press the **ENTER** button twice.
The Adjust Color menu appears.
- 4** Use the **◀/CANCEL** button or the **▲/CONTINUE** button to select **Reset All**, and press the **ENTER** button.
- 5** Use the **◀/CANCEL** button or the **▲/CONTINUE** button to select **Yes**, and press **ENTER** button twice.
The Color Test menu appears.
- 6** Press the **ENTER** button.
Color Adjust Test pages that use the previous value and the new values are printed.
- 7** Press the **ENTER** button.
The Apply Changes menu appears.
- 8** Use the **◀/CANCEL** button or the **▲/CONTINUE** button to select **Yes**, and press the **ENTER** button.
The Ready menu appears.

Before operation

Acceptable documents

The documents that meet the following conditions can be scanned.

For scanner glass:

- Max. 216 mm x 356 mm (8.5" x 14")

For ADF (Automatic Document Feeder):

- Document width: 100 mm to 216 mm (3.94" to 8.5")
- Document length: 178 mm to 356 mm (7" to 14")
- ADF tray: up to 50 pages of document
[75 g/m² (20 lbs.) fresh paper]
- Document weight: 60 g/m² to 127.5 g/m² (16 lbs. to 34 lbs.)

Unacceptable documents

Do not use the following types of documents.

For scanner glass:

- Document on which ink, paste or correction fluid has not completely dried
- Heavily curled or creased paper

For ADF (Automatic Document Feeder):

- Document on which ink, paste or correction fluid has not completely dried
- Do not use the following types of documents to avoid a jam or prevent the documents from getting torn.
 - Original or precious photographs
 - Paper with curls, wrinkles, twists
 - Documents bound with clips or staples
 - Paper with carbon on the backside or rough paper
 - Transparency or electrostatically charged paper
 - Labels or paper with holes
 - Extremely thin or thick paper
 - Document with coated surfaces and poorly fixed
 - Plastic or metal sheet

IMPORTANT:

- All literary, artistic and typographical works are copyrighted. While certain reproduction of copyrighted work may be permitted for "fair dealing" e.g., for research, private study or for the purpose of criticism or review, generally, reproduction of copyrighted works are not permitted without the permission of the copyright owner.

Placing documents

Perform the following and go to [page 188](#) or [194](#) depending upon the operation.

■ Using the ADF

- 1**
 - a)** Fan the stack of documents and tap it on a level surface to avoid document jams.
 - b)** Insert the documents fully in the ADF tray with the printed sides facing up and top of the documents first.
The height of document should not exceed the limit mark on the document guide, or it may cause a jam.
 - c)** Adjust the document guides to the width of the documents.

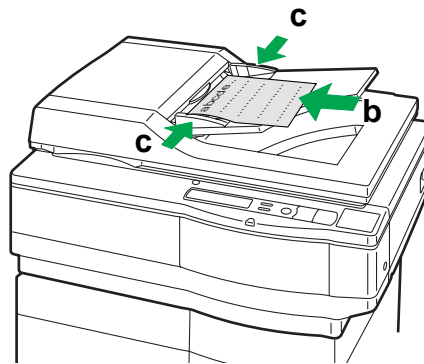

■ Using the scanner glass

- 1**
 - a) Open the ADF.
 - b) Place the document face down on the scanner glass referring to the document position marks.
 - c) Close the ADF.

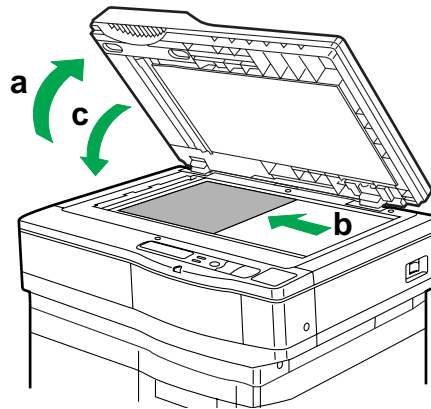

NOTES:

- When scanning a book type document of more than 2 cm (0.79") thickness, scan it with the ADF open.
- Scanning a document using the flatbed (scanner glass) produces better quality than scanning it using the ADF. For best scanning quality use flatbed scanning.
- If you scan poorly fixed originals such as catalogs using ADF, they may be partially stained. To prevent the originals from getting stained, use the flatbed scanning.

Scanning documents

Any acceptable documents ([see page 186](#)) can be scanned.

■ For Windows 3.1 users

To scan the documents, TWAIN compliant application must be installed.

- 1** Start Windows 3.1.
- 2** From the **Program Manager**, click the **Window** menu. Then click **TWAIN compliant application**.
The TWAIN compliant application window is displayed.
- 3** Click the **File** menu, then click **Acquire Image**.

- 4** Click **Select Source...**
The Select Source window is displayed.
- 5** Select Panasonic KX-PS8100 16 bit Driver, then click **Select**.
- 6** Click the **File** menu, then click **Acquire Image**, and go to step 8.

■ For Windows 95/Windows NT 4.0 users

- 1** Start Windows 95/Windows NT 4.0.
- 2** Click **Start**, select **Programs**, and click **CorelDRAW Select Edition**.
- 3** Click **Corel PHOTO-PAINT Select Edition**.
The Corel PHOTO-PAINT Select Edition window is displayed.
- 4** Click the **File** menu, and click **Acquire Image**.
- 5** Click **Select Source...**
The Select Source window is displayed.
- 6** Select Panasonic KX-PS8100 32bit Driver, then click **Select**.
- 7** Click the **File** menu, and click **Acquire Image**.

8 Click **Acquire...**

The Panasonic Scanner Driver and the Preview Screen are displayed.

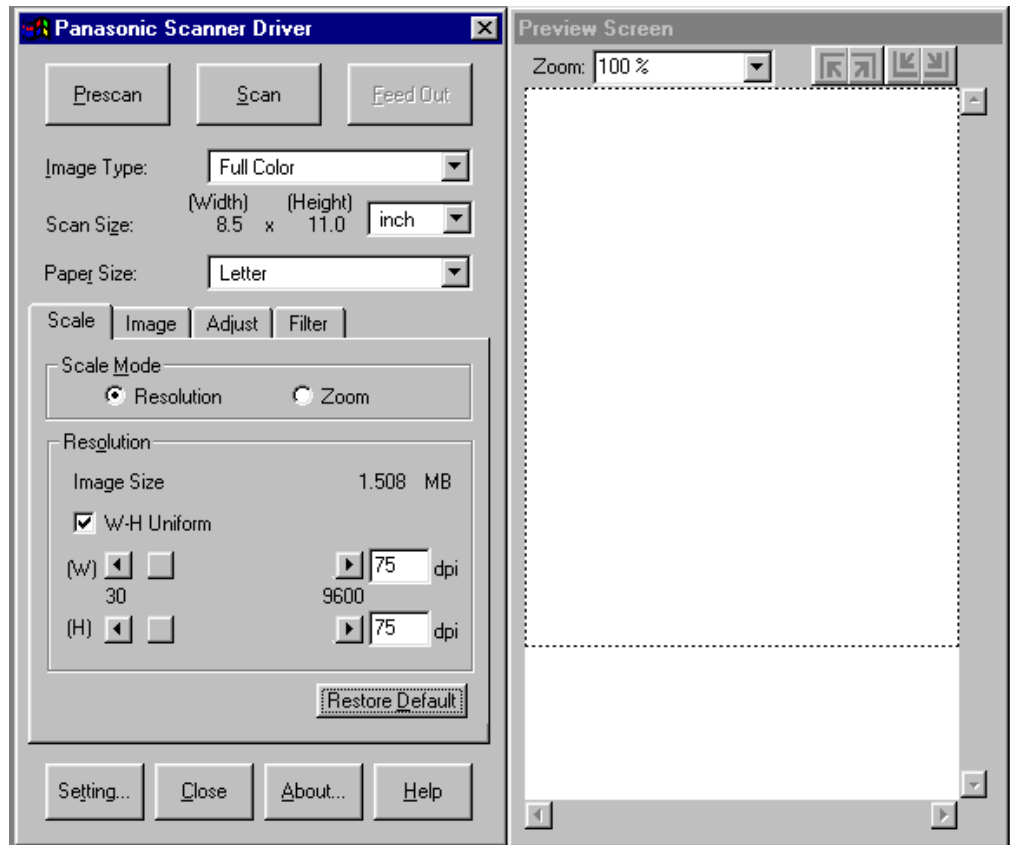

9 Place the document(s) in the ADF tray or on the scanner glass (see page 187-188).

10 Click **Prescan** to display the document image in the **Preview Screen** and select a scanning area.

11 Click **Scan**.
The scanner will start scanning the document(s).

NOTE:

- For additional information, see the *Utilities and Drivers Reference Guide*.

■ For Macintosh users

The Panasonic KX-PS8100 has two scanner drivers, TWAIN as well as Photoshop Plug-in. Perform the following depending upon the scanner driver.

To use the TWAIN scanner driver:

- 1** Start Mac OS.
- 2** Run your TWAIN compliant application.
- 3** Click the **File** menu, and click **Import**.
- 4** Click **Twain Acquire...**, and go to step 5.
The Panasonic Scanner Driver and the Preview Screen are displayed.

To use the Photoshop Plug-in scanner driver:

- 1** Start Mac OS.
- 2** Run your Photoshop Plug-in compliant application.
- 3** Click the **File** menu, and click **Import**.
- 4** Click **KX-PS8100 Scanner...**
The Panasonic Scanner Driver and the Preview Screen are displayed.
- 5** Place the document(s) in the ADF tray or on the scanner glass (see page 187-188).
- 6** Click **Prescan** to display the document image in the **Preview Screen** and select a scanning area.
- 7** Click **Scan**.
The scanner will start scanning the document(s).

NOTE:

- For additional information, see the *Utilities and Drivers Reference Guide*.

Printing a scanned document

Make sure the document that you wish to print has been selected.

■ For Windows 3.1 users

- 1** Click the **File** menu, then click **Print**.
The Print window is displayed.
 - Make sure that “Panasonic KX-PS8100” is selected.
- 2** Click **OK**.
After several minutes, the document will be printed. Print time depends on the size of the document.

NOTE:

- For additional information, see the *Utilities and Drivers Reference Guide*.

■ For Windows 95/Windows NT 4.0/Macintosh users

- 1** Click the **File** menu, then click **Print**.
The Print window is displayed.
 - Make sure that “Panasonic KX-PS8100” is selected.
- 2** Click **OK**.
After several minutes, the document will be printed. Print time depends on the size of the document.

NOTE:

- For additional information, see the *Utilities and Drivers Reference Guide*.

Saving a scanned document

Make sure the document that you wish to save has been selected.

■ **For Windows 3.1 users**

- 1** Click the **File** menu, then click **Save As...**
The Save an Image to Disk window is displayed.
- 2** Enter the File Name.
- 3** Select the File Type.
- 4** Click **OK**.
The document will be saved.

■ **For Windows 95/Windows NT 4.0/Macintosh users**

- 1** Click the **File** menu, then click **Save As...**
The Save an Image to Disk window is displayed.
- 2** Enter the File Name.
- 3** Select the File Type.
- 4** Click **Save**.
The document will be saved.

Duplicating documents

Any acceptable documents (see page 186) can be duplicated. Before you start operation, make sure the printer is ready. (The READY indicator is illuminated.) There are two methods to duplicate a document:

- A. Using the Digital Duplicator Utility (see below)
- B. Using the scanner panel (see page 196)

Using the Digital Duplicator Utility

■ For Windows 3.1 users

- 1** From the **Program Manager**, double-click the **KX-PS8100 Utilities** icon and double-click the **Digital Duplicator Utility** icon.

The Digital Duplicator Utility window is displayed. Go to [step 2](#).

■ For Windows 95/Windows NT 4.0 users

- 1** Click **Start**, select **Programs**, and then click **KX-PS8100 Utilities**. Next, click **Digital Duplicator Utility**.

The Digital Duplicator Utility window is displayed.

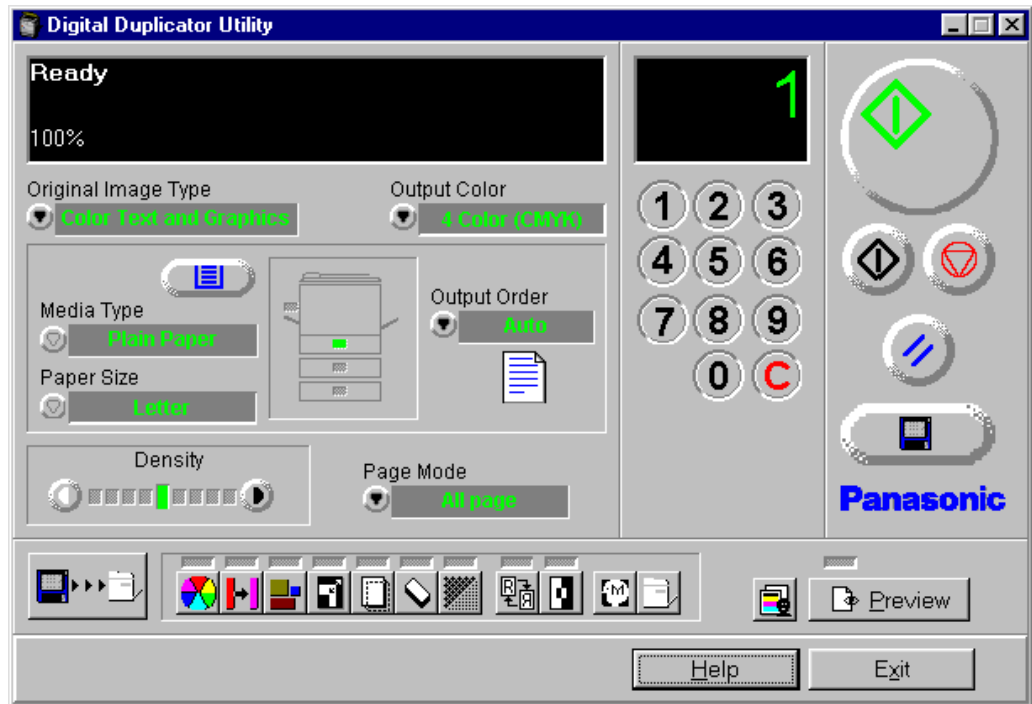

- 2** Place the document(s) in the ADF tray or on the scanner glass (see page 187-188).

NOTE:

- Scanning a document using the flatbed (scanner glass) produces better quality than using the ADF. For best quality use flatbed scanning.

3 If you wish to make more than one duplicate, set the number of duplicates using numbers 0-9.

- You can set the number of duplicates between 1 and 999.
- Clicking  will reset the number of duplicates to 1.

4 If you wish to use the multi-purpose tray, perform the following and go to step 5.

a) Insert the paper in the multi-purpose tray.

- For instructions on how to insert the media in the multi-purpose tray, [see page 52](#).

b) Click  to select the multi-purpose tray.

- The green indicator shows which tray has been selected.

c) Select a Media Type and a Paper Size.

5 To produce a high quality duplicate(s) of the original document(s), perform the following by referring to the table below:

a) Select an image type that corresponds to your original document by clicking on ▼ at the left of **Original Image Type** box.

Image type	Original document
Color Text and Graphics	Color text and graphics
Color Photo	Color photo
B/W Text	Text
B/W Halftone, Photo	Monochrome halftone or photo original

b) Click  .

NOTES:

- When making a duplicate of a black and white document, click  (the **B/W Text Start** button) to make a duplicate quickly.
- For additional information, see the *Utilities and Drivers Reference Guide*.

Using the scanner panel

Scanner panel

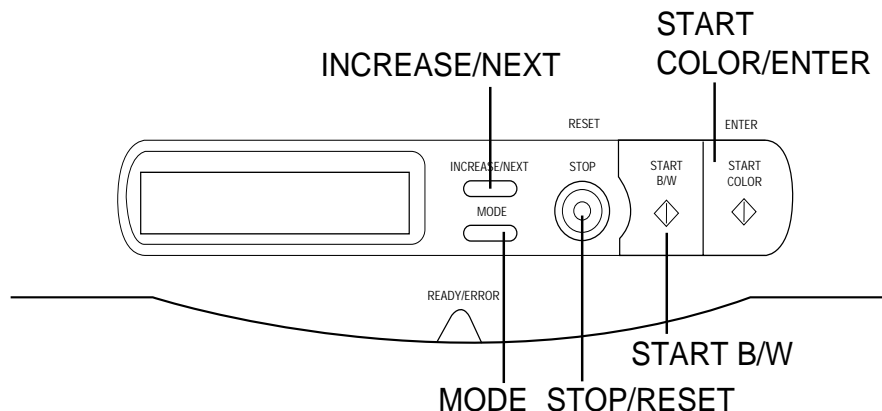

- 1** Place the document in the ADF tray or on the scanner glass (see page 187-188).
- 2** When using the multi-purpose tray, be sure to select **MP Tray** in the **Paper Source** menu (see page 205).
 - For instructions on how to set the scanner menu, see page 204.
 - For instructions on how to insert the media in the multi-purpose tray, see page 52.
- 3** When both printer and scanner are in the ready mode, press the button(s) that corresponds to your original document.

Button	Print type	Original document
START COLOR	Text and Graphics	Color text and graphics
MODE + START COLOR*	Photo	Color photo
START B/W	B/W Text	Text
MODE + START B/W	B/W Halftone, Photo	Monochrome halftone or photo original

* For plain paper only

NOTES:

- When making a color duplicate, pressing the **MODE + START COLOR** button makes a duplicate more quickly than pressing the **START COLOR** button. However, it slightly increases the toner consumption.
- When making a duplicate of a black and white document, press **START B/W** button to make a duplicate quickly. If you press **START COLOR** button, you will still get a black and white duplicate, but the process will take slightly longer.
- Before the printer can print after being in the Power Saver Mode [“Sleep” is displayed on the scanner LCD and “Ready (Sleep)” is displayed on the printer LCD.], it needs to warm up to heat up the fuser.
- When the scanner panel is left idle for 5 minutes, all menu settings will automatically return to the Menu Default. (See “Menu Default” on [page 208](#))

The printer panel functions and menus

The printer panel enables you to set options and view the status of the printer and print jobs. This section provides information about:

- Status messages and error messages
- Main menus you can access from the printer panel
- Printing printer information pages from the printer panel

For a detailed explanation of the activity lights and buttons on the printer panel, [see “Printer panel overview” on page 38.](#)

Printer’s status messages

When the printer is printing normally, status information about current jobs appears in the display window. The messages are:

- Ready—Displays while the printer is ready to print but not processing or printing a job.
- Printing—Displays while a job is printing.
- Processing—Displays while the job is processing.
- Canceling Job—Appears when you cancel a print job.
- Ready(Sleep)—Appears when the printer is in an Power Saver mode. This mode can reduce the total power consumption of the printer to less than 35 watts. Full power mode is restored when the printer receives a job or when you press the MENU/EXIT button or print a page at the printer.

Basic Operations

Before the printer can print after being in Ready(Sleep), it needs to warm up to heat up the fuser. The actual warm-up time depends on how long the printer has been in Power Saver mode. If the printer has been in Ready(Sleep) Power Saver mode for a long time, the warm-up period will be longer.

Printer's error messages

If there is a printing problem, the Error indicator will be on, and an error will appear in the display window. For information about error messages, [see "Printer LCD panel" on page 248.](#)

Printer's main menus

The table below describes the printer's main menus.

- Press the **MENU/EXIT** button to access the menus.
- Press the **▲/CONTINUE** or **◀/CANCEL** button to scroll through the menus.

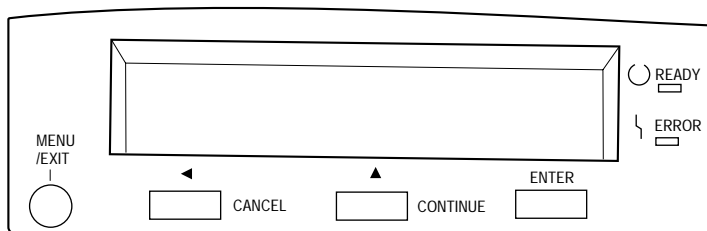

Some of these menus (Parallel Port Setup, Network Port Setup, and Network Protocol Setup) are used to configure the printer's initial Setup, which must be completed before users can send jobs to the printer. For information on performing the initial Setup from the printer panel, [see page 145.](#)

The Main menus are displayed in the upper line of the printer panel, and the Selection menus are displayed in the lower line.

Main menus	To specify	Notes
Test Page	Printing one of three sample pages, stored in the printer's ROM: PS Font List, Test Print, and Configuration page.	See page 202

(Continued)

Main menus	To specify	Notes
Check And Print* ¹	Printing additional copies of a Check and Print job after the initial Check and Print copy has been printed. Specify the number of additional copies of the job to print using the Check and Print screens from the printer panel.	For Macintosh, see Chapter 1 of Part 3 in <i>Utilities and Drivers Reference Guide</i> . For Windows, see Chapter 2 of Part 3 in <i>Utilities and Drivers Reference Guide</i> .
Bias Adjustment	Toner density	See Chapter 7 "Color Calibration".
Visual Calibration	Color calibration of the printer	See Chapter 7 "Color Calibration".
Color Adjustment	Toner density and brightness	See Chapter 7 "Color Calibration".
Maintenance	Display the remaining percentage of each of the consumables. <ul style="list-style-type: none"> • Page Count • Toner Cartridge • Imaging Unit • Transfer Unit • Fuser Unit • Oil Roll 	See page 216
Image Area	The amount of the last printed page covered by toner, for all toner colors. The average amount of the printed page covered by toner, for all toner colors since a toner cartridge replacement.	See page 217
Power Saver	Enable entering Power Saver mode which can reduce the total power consumption of the printer to less than 35 watts.	See page 146

(Continued)

*¹ This menu is available only on printers with a hard disk drive.

Main menus	To specify	Notes
Parallel Port Setup	<p>Enable printing through the parallel port, set parallel port timeout, specify data mode.</p> <ul style="list-style-type: none"> Parallel Port Setup <ul style="list-style-type: none"> Enable Parallel ? Timeout Data Mode 	See page 146
Network Port Setup	<p>Specify Ethernet or Token Ring settings for network connections to the printer.</p> <ul style="list-style-type: none"> Ethernet Setup <ul style="list-style-type: none"> Ethernet Speed Token Ring Setup <ul style="list-style-type: none"> Token Ring Speed Max. Frame Size Source Routing Req. All Route Resp. All Route 	See page 146
Network Protocol Setup	<p>Specify settings for network protocols, including TCP/IP, AppleTalk, and IPX/SPX.</p> <ul style="list-style-type: none"> TCP/IP Setup <ul style="list-style-type: none"> Enable TCP/IP ? Ethernet IP Address or Token Ring IP Address*¹ Ethernet Subnet Mask or Token Ring Subnet Mask*¹ Gateway Address AppleTalk Setup <ul style="list-style-type: none"> Enable AppleTalk ? AppleTalk Zone IPX/SPX Setup <ul style="list-style-type: none"> Enable IPX/SPX ? 	See page 148
Language	Specify the language of the LCD text, and the language used in the Test, Configuration, and Calibration pages.	See page 150
Reset Queues* ²	Clear all jobs from queues and clear the Job Log.	See page 150

(Continued)

*¹ These menus are available when using Token Ring network card.

*² This menu is available only on printers with a hard disk drive.

Main menus	To specify	Notes
Hard Disk* ¹	Initialize hard disk drive. <ul style="list-style-type: none">• Format?	See page 150

*¹This menu is available only on printers with a hard disk drive.

NOTE:



- Network Port Setup and Network Protocol Setup appear only for networked printers.

Printing pages from the printer panel

There are several pages that you can print from the printer panel. This section provides instructions for printing a Test Print, a Configuration Page, and PostScript Font List.

The Test Print includes a color sample as well as the printer's name, enabled network protocols, memory configurations, and installed options.

The Configuration Page lists information about the printer, the current Setup configuration, and the number of printer fonts. It's a good idea to print a Configuration Page before you make Setup changes, in case you need to restore some settings later.

The PostScript Font List prints out the list of available printer fonts.

You can print a Test Print before you set up the printer—or at any other time from the “Ready” or the “Ready(Sleep)” screen.

To print a Test Print:

- 1** Turn on the printer and allow it to warm up.
Messages appear on the printer panel as the KX-PS8100 printer runs through its power-up tests.
- 2** From the **Ready** screen, press the **MENU/EXIT** button on the printer panel.
- 3** Press the **ENTER** button.
- 4** Press the **▲/CONTINUE** button until you see **Test Print** and then press the **ENTER** button.
- 5** Examine the quality of the Test Print.

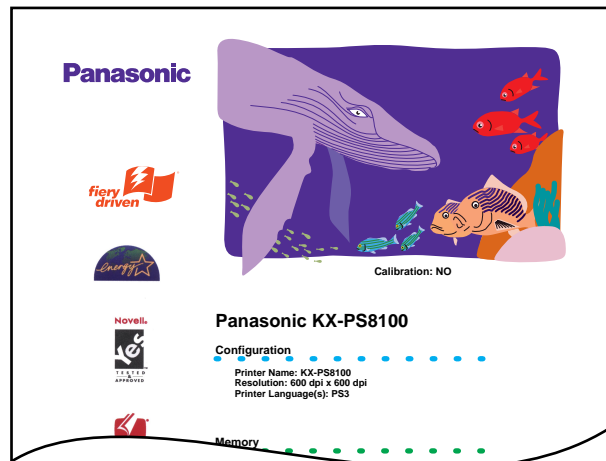

Test Print

To print a Configuration Page or PostScript Font List:

- 1** From the **Ready** screen, press the **MENU/EXIT** button on the printer panel.
- 2** Press the **ENTER** button to display a list of available pages.
- 3** Press the **▲/CONTINUE** (or **◀/CANCEL**) button until you see **Configuration Page** or **PS Font List** in the window and press the **ENTER** button.

The KX-PS8100 prints a Configuration Page or PostScript Font List.

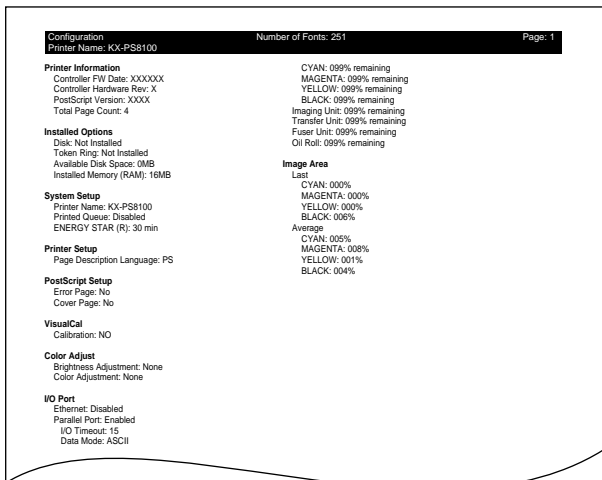

Configuration Page

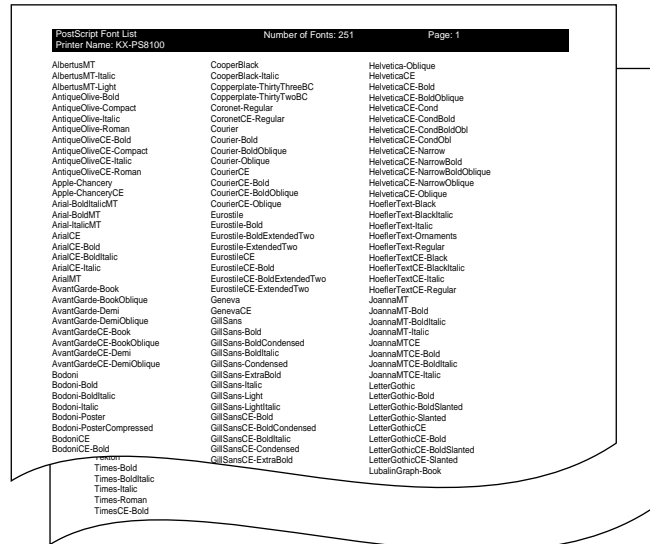

PostScript Font List

The scanner panel functions and menus

The scanner panel enables you to set menus and view the status of the scanner. This section provides information about:

- Status messages and error messages
- Main menus you can access from the scanner panel

For a detailed explanation of the activity lights and buttons on the scanner panel, [see “Scanner panel overview” on page 35.](#)

Scanner’s status messages

When the scanner is scanning normally, status information about current jobs appears in the display window. The messages are:

- Ready—Displays while the scanner is ready to print but not processing or scanning a job.
- Scanning—Displays while a job is scanning.
- Sleep—Appears when the printer is in an Power Saver mode.

Scanner’s error messages

If there is a scanning problem, the ERROR indicator will be on, and an error will appear in the display window. For information about error messages, [see “Scanner LCD panel” on page 246.](#)

Scanner’s main menus

The table on the next page describes the scanner’s main menus.

The scanner Menu mode includes a Main menu and a Selection menu that can be changed from the scanner panel.

In the duplicate ready status (when “Ready” is displayed in the upper line of the LCD), pressing the MODE button will allow you to enter the Menu mode. Press the MODE button to display the next menu.

- Press the **MODE** button to display the next menu.
- Press the **INCREASE/NEXT** button to display the next selection.
- Press the **START/ENTER** button to activate the selection.

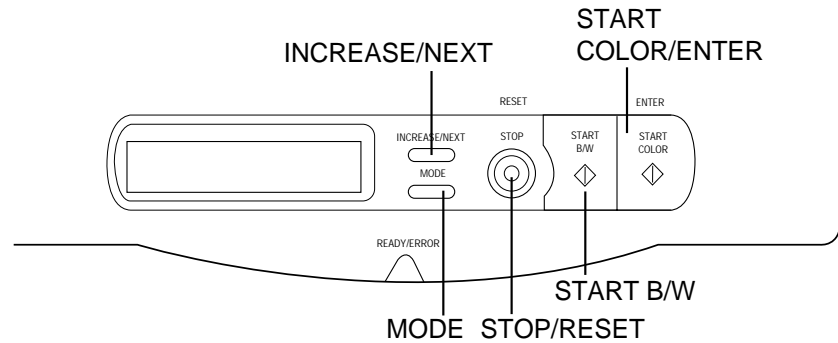

Note the factory defaults before changing any settings.

The Main menus are displayed in the upper line of the scanner panel, and the Selection menus are displayed in the lower line.

Main menus	To specify	Notes
Density	<p>Adjusts a print density from level 1 to 5. Level 1 produces the lightest printout (duplicate), and level 5 produces the darkest.</p> <p> <input type="checkbox"/> <input type="checkbox"/> <input type="checkbox"/> <input type="checkbox"/> (Level 1) <input checked="" type="checkbox"/> <input type="checkbox"/> <input type="checkbox"/> <input type="checkbox"/> (Level 2) <input checked="" type="checkbox"/> <input checked="" type="checkbox"/> <input type="checkbox"/> <input type="checkbox"/> ^{*1} (Level 3) <input checked="" type="checkbox"/> <input checked="" type="checkbox"/> <input checked="" type="checkbox"/> <input type="checkbox"/> (Level 4) <input checked="" type="checkbox"/> <input checked="" type="checkbox"/> <input checked="" type="checkbox"/> <input checked="" type="checkbox"/> (Level 5) </p>	
Paper Source	<p>Selects a media tray.</p> <ul style="list-style-type: none"> • Media (Upper) Tray ^{*1} • MP Tray • Middle Tray • Lower Tray 	<p>“Upper”, “Middle Tray” and “Lower Tray” are displayed only when the optional 2nd cassette feeder is attached.</p>

^{*1} Factory default setting

(Continued)

Basic Operations

Main menus	To specify	Notes
MPT Paper Size	<p>Selects the same media size that you have inserted in the multi-purpose tray. Only Letter, A4 and Legal media sizes can be used with the multi-purpose tray.</p> <ul style="list-style-type: none"> • Letter ^{*1} • A4 ^{*1} • Legal 	
MPT Paper Type	<p>Selects the same media type that you have inserted in the multi-purpose tray.</p> <ul style="list-style-type: none"> • Plain Paper ^{*2} • Transparency • Label • Coated Paper • Paper 2nd Side 	
Quality	<p>Allows you to select a resolution at which you wish to make a duplicate of your original document.</p> <ul style="list-style-type: none"> • Standard ^{*2} • Fine ^{*3} 	<p>“Standard”</p> <ul style="list-style-type: none"> • in case of B/W Text 300 x 300 dpi (Scanning) 1200 x 600 dpi (Printing) • else 600 x 300 dpi (Scanning) 1200 x 600 dpi (Printing) <p>“Fine”</p> <ul style="list-style-type: none"> 600 x 600 dpi (Scanning) 1200 x 1200 dpi (Printing)

(Continued)

^{*1} Factory default setting is either Letter or A4

^{*2} Factory default setting

^{*3} A minimum of 48 MB of SDRAM DIMM is required to select this mode.

Main menus	To specify	Notes
Output Order (ADF)	<p>Select Face Up or Face Down printing.</p> <ul style="list-style-type: none"> • Face Down ^{*1} Makes a duplicate(s) of your original document(s) face down in the printer's output tray. • Face Up Makes a duplicate(s) of your original document(s) face up in the printer's output tray. <p>NOTE:</p> <ul style="list-style-type: none"> • The Output Order (ADF) is effective only when using ADF. When using the flatbed (scanner glass) or the multi-purpose tray, your duplicate will always be printed face up. 	
Power Saver	<p>To conserve energy and operating cost, this scanner is provided with a programmable power save feature. Scanner is factory set with the power save feature turned on.</p> <p>If Power Saver is set to On, the scanner enters the Power Saver mode when it is idle for approximately 5 minutes. To reactivate the scanner, scan a document.</p> <p>The Power Saver setting will remain effective even if the scanner is turned off.</p> <ul style="list-style-type: none"> • On ^{*1} • Off <p>NOTE:</p> <ul style="list-style-type: none"> • When the printer is in the Power Saver mode ["Sleep" is displayed on the scanner LCD.], press any button on the scanner panel to release the Power Saver mode. 	

^{*1} Factory default setting

(Continued)

Basic Operations

Main menus	To specify	Notes
Language	English* ¹ French German	
Menu Setting	If the START COLOR/ENTER button is pressed when Save is selected for Menu Default , all current menu settings will remain effective even if the scanner is turned off. If Reset is selected, all menu settings except the Power Saver setting will return to the factory default settings. <ul style="list-style-type: none"> • Save *¹ • Reset 	
Display Version	—	These menus are used for service purpose only and the displayed contents cannot be changed.
Display Counter	—	

*¹ Factory default setting

Cleaning

Periodic cleaning of the unit is recommended, depending on the environment in which the KX-PS8100 is used. You should clean the unit:

- At least once a month.
- When the scanner/printer experiences frequent media jams.
- When scan/print quality starts to deteriorate.

Scanner

To clean the external of the scanner:

- 1** Turn the power OFF.
- 2** Clean the cover, the scanner glass, the ADF scanner glass, the document cover and the white sheet with a soft cloth. Use any mild commercial cleaner.

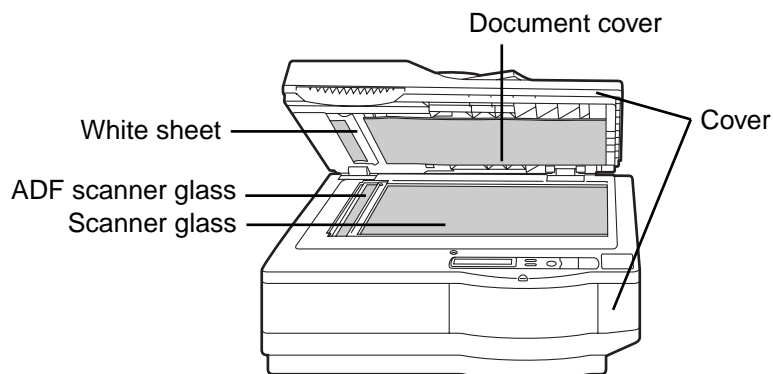

CAUTION:

- Do not use benzine, thinner, aerosol cleaners or any abrasive powder.

To clean the internal of the scanner:

When using isopropyl alcohol with a lint-free cloth, make sure that the alcohol is at least 90% pure, obtainable from your local pharmacy. (Do not use rubbing alcohol; it can damage the scanner)

- 1** Turn the power OFF.

- 2 Open the ADF top cover by lifting the cover release tab.

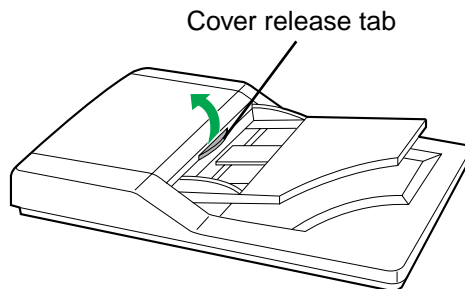

- 3 Clean the rollers with a dry lint-free cloth that has been moistened with isopropyl alcohol.

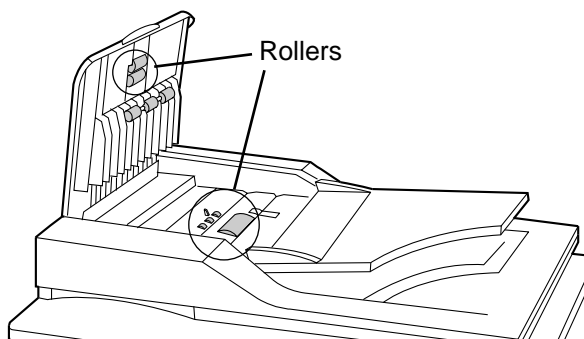

Printer

To clean the external of the printer:

- 1 Turn the power OFF.
- 2 Clean all the covers with a soft cloth, using any mild commercial cleaner.

CAUTION:

- Do not use benzine, thinner, aerosol cleaners, or any abrasive powder.

NOTE:

- When using isopropyl alcohol with a lint-free cloth, make sure that the alcohol is at least 90% pure, obtainable from your local pharmacy. (Do not use rubbing alcohol; it can damage the printer.)

To clean the paper-pick rollers:

1 Slide the media tray out (you do not have to remove it) to allow access to the paper-pick rollers.

2 Open the left side door.

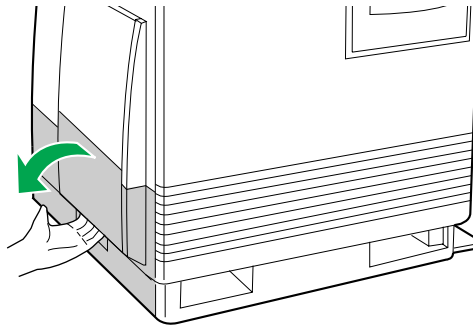

3 Use the green handles to pull out the paper feeder.

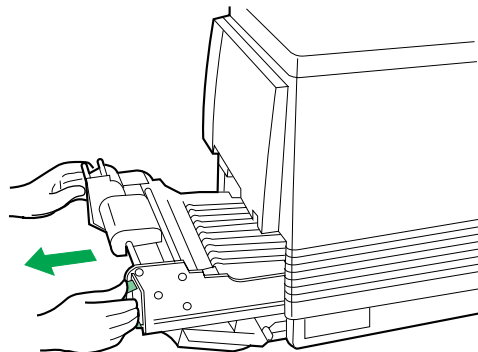

4 Gently rotate the paper-pick rollers 180° (the paper-pick rollers are D-shaped) and wipe them with a lint-free cloth moistened with isopropyl alcohol.

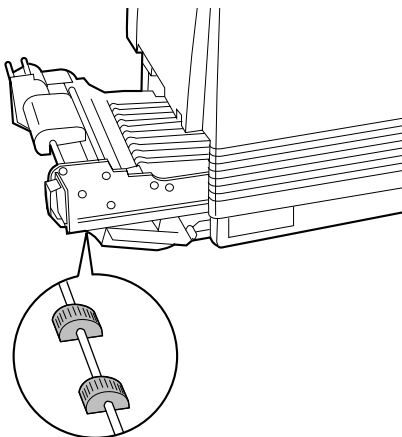

- 5** a) Reinsert the paper feeder.
b) Close the left side door.

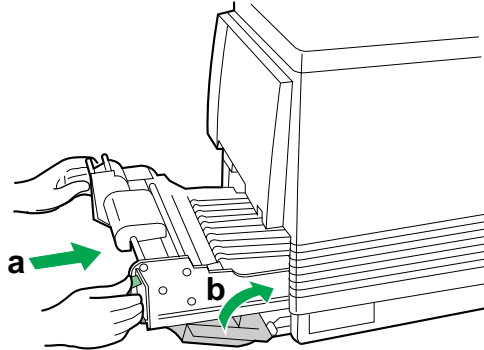

- 6** Slide the media tray back into place.

NOTE:

- If you have a 2nd cassette feeder, you may also need to clean the rollers for the middle and lower media trays, which are accessed through the **lower** left side door.

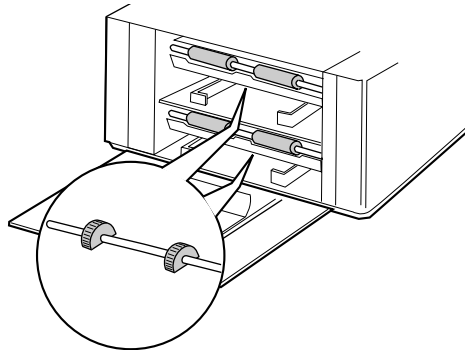

Life of components

The life of components will vary depending on what you print and the media you use and environment.

Panasonic shows life based on an average of 5% coverage of the printable area and standard density for any one color.

In case of Monochrome printing, 1 color (Black only) is used.
In case of full color printing, 4 colors (Cyan, Magenta, Yellow and Black) are used.

The frequency of replacement will vary, depending on the complexity of the prints and the percentage of coverage of each color and print density.

For details on the life of components, refer to next "User replaceable components".

User replaceable components

When the printer panel indicates that a supply needs to be replaced, make sure that you have replacement supplies on hand. The printer may continue to print until the supply is completely used up; but then it stops until you replace the indicated supply. The frequency of replacement will vary, depending on the complexity of the prints and the percentage of coverage of each color and print density.

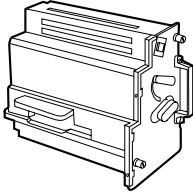
Printer component	Printer panel message	Average life
	Imaging Unit wearing out Change the color imaging unit soon.	Monochrome 57,000 pages or Color 14,250 pages
	Imaging Unit Worn out Change the color imaging unit now.	Monochrome 60,000 pages or Color 15,000 pages

(Continued)

*1 These figures are based on an average of 5% coverage of the printable area and standard density for any one color (refer to Example A below left: **Monochrome 5% coverage**).

In case of Monochrome printing, 1 color (Black only) is used.

In case of full color printing, 4 colors (Cyan, Magenta, Yellow and Black) are used.

Therefore the life of Color imaging unit is 60,000 pages at Monochrome printing (Black only), 15,000 pages at full color printing (4 color mode) at 5% coverage per color.

Print pattern	Coverage of the printable area (%)				Life (pages)
	Cyan	Magenta	Yellow	Black	
Monochrome 5% coverage (Example A)	0	0	0	5	60,000
Full color 5% coverage	5	5	5	5	15,000
Full color 10% coverage	10	10	10	10	7,500
Full color (Example B)	4	10	19	31	4,688
Full color (Example C)	32	22	29	17	3,000

NOTE:

- Each file's coverage is measured by KX-PS8100 pixel counter on letter size. The coverage will differ with printers.

Example A

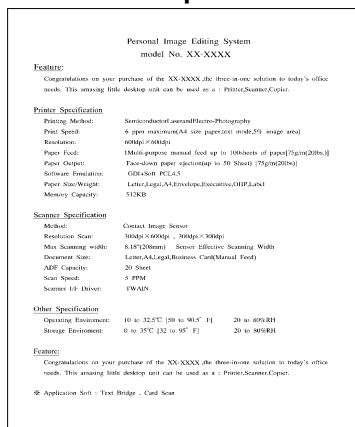

Example B



Example C

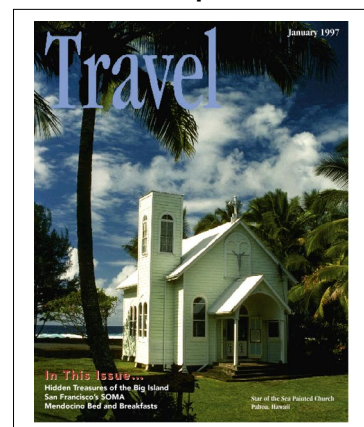

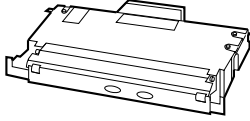
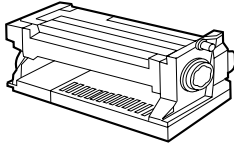
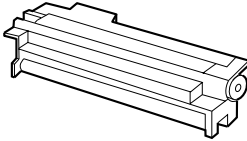
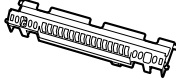
Printer component	Printer panel message	Average life
Toner cartridges* ¹ * ² 	Low <Color> Toner Change the toner cartridge soon.	12,000 pages (Black) or 10,000 pages (CMY)
	<Color> Toner Empty Change the toner cartridge now.	
Fuser unit* ¹ * ³ (oil supply roll installed) 	Fuser Unit wearing out <i>alternates with</i> Oil Roll wearing out Change the fuser unit soon.	28,500 pages
	Fuser Unit and Oil Roll Worn out Change the fuser unit now.	31,000 pages
Oil supply roll* ¹ * ³  Cleaning pad enclosed 	Oil Roll wearing out Change the oil supply roll and cleaning pad soon.	15,000 pages
	Oil Roll Worn out Change the oil supply roll and cleaning pad now.	15,500 pages

(Continued)

*¹ See *¹ on [page 214](#).

*² The starter cartridges that ship with the printer have an average life of approximately 3,000 pages, based on an average of 5% coverage.

*³ **Specialty media (Transparencies, coated paper, etc.) will result in shortening the life of a consumable to maintain better print quality.** When one page is printed on this type of media, 2 pages are counted. So when only speciality media is used, it may reduce the life of components by half. When replacing the fuser unit, replace the oil supply roll as well. **Do not insert the used oil supply roll into the new fuser unit; it may damage the new fuser unit.**

*⁴ Printing a large quantity of pages with high coverage will result in the message “Fuser Unit wearing out” to be displayed earlier than its expected life. In this case, replace the fuser unit.

NOTE:

- If you print with high density when “Low <Color> Toner” is displayed, you may get faded printout before “<Color> Toner Empty” is displayed.

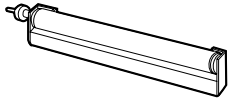
Printer component	Printer panel message	Average life
Transfer unit* ¹ 	<div style="border: 1px solid gray; padding: 5px; background-color: #f0f0f0;"> Transfer wearing out Change the transfer unit soon. </div>	80,000 pages

*¹When you have just replaced transfer unit, you must select Yes in the New Transfer Unit menu. [See page 217.](#)

Displaying the life of supplies and coverage of toner

Maintenance

This menu shows how much percentage of each consumable life remains to be used. Please note that the values shown here is just the approximate value and are not always correct. So the consumable wearing warning message might occur regardless of the displayed values.

Page Count—It shows the pages your KX-PS8100 has printed since your purchase of the system.

Toner Cartridge—It shows the percentage of CYAN, MAGENTA, YELLOW and BLACK toner cartridges remaining.

- CYAN : ###%Remaining
- MAGENTA : ###%Remaining
- YELLOW : ###%Remaining
- BLACK : ###%Remaining

NOTE:

- If you replace the toner cartridge before “Low <Color> Toner” or “<Color> Toner Empty” is displayed, the value of the toner cartridge remaining will be incorrect.

Imaging Unit—“###% remaining” shows the percentage of the life of color imaging unit remaining.

Transfer Unit—It shows the percentage of the transfer unit remaining.

- ###% remaining
It shows the percentage of the transfer unit remaining.
- New Transfer Unit (No/Yes)
You must select Yes when you have just replaced transfer unit.
The life will be reset to 100% remaining by selecting Yes.

Fuser Unit—“###% remaining” shows the percentage of the fuser unit remaining.

Oil Roll—“###% remaining” shows the percentage of the oil roll remaining.

Image area

Last—It shows the percentage of the whole printable area covered by each toner in the previously printed page. This menu cannot show the value correctly just after the printer was turned on.

- CYAN: ###%
- MAGENTA: ###%
- YELLOW: ###%
- BLACK: ###%

Average—It shows the average percentage of the printable area of all pages printed covered by each toner.

- CYAN: ###%
- MAGENTA: ###%
- YELLOW: ###%
- BLACK: ###%

Clearing media jams

Scanner

To clear media jams in the document input area:

- 1**
 - a) Open the ADF top cover by lifting the cover release tab.
 - b) Remove the jammed document.

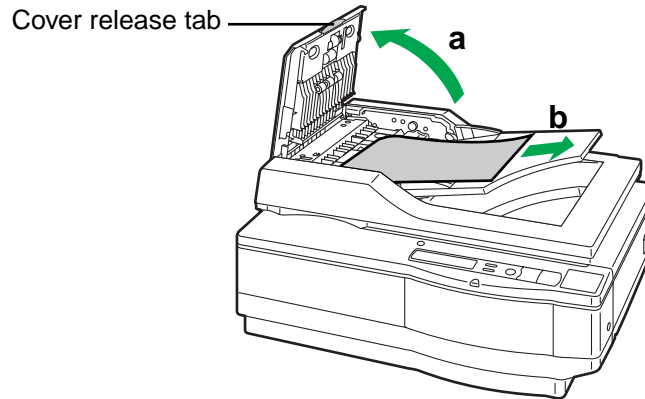

OR

- a) Open the ADF top cover by lifting the cover release tab.
- b) Open the ADF.
- c) Remove the jammed document.

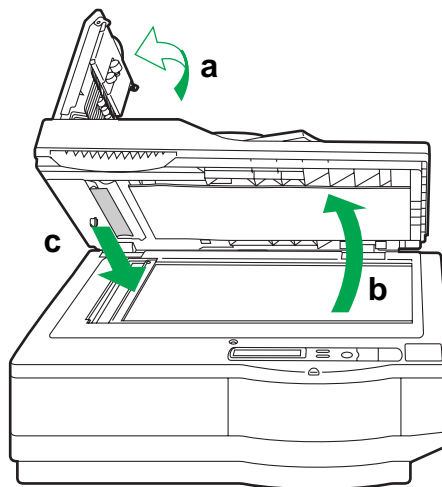

To clear media jams in the document output area:

- 1**
 - a) Open the ADF tray.
 - b) Remove the jammed document while keeping the ADF tray raised.

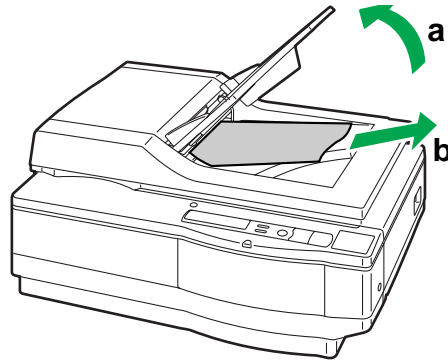

OR

- a) Open the ADF.
- b) Open the exit guide.
- c) Remove the jammed document.

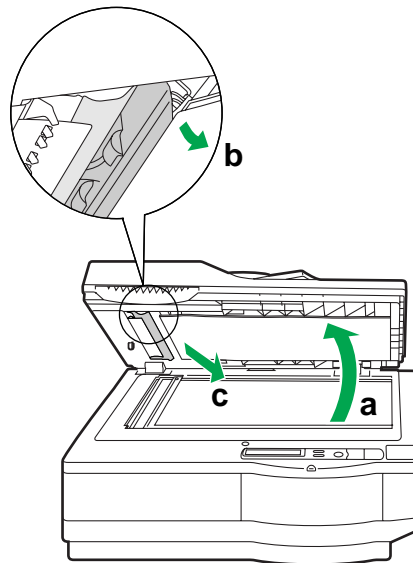

Printer

If the printer has frequent media jams, make sure that you follow these guidelines:

- Always use high-quality laser paper and transparencies. [See pages 291 and 293.](#)
- Make sure that you load specialty media only in the multi-purpose tray and that you set the media thickness switch to the correct setting for the media used.

If a media jam occurs, the printer panel reports “Jam at <Location>”, where “<Locations>” are the various sensors throughout the paper path, shown as A through E in the illustration below.

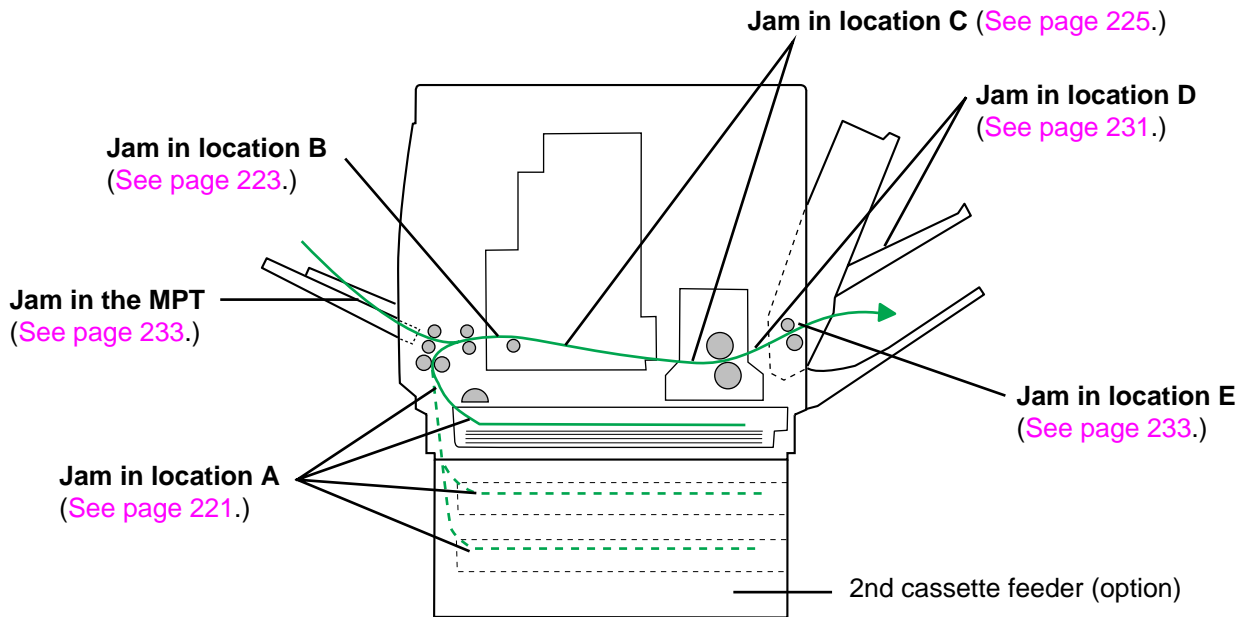

NOTE:

- After removing the jammed media, **open and close the printer’s front door** to clear the error message from the printer LCD panel.

To clear media jams in location A:

- 1** Open the left side door corresponding to the selected media tray and remove the jammed media.

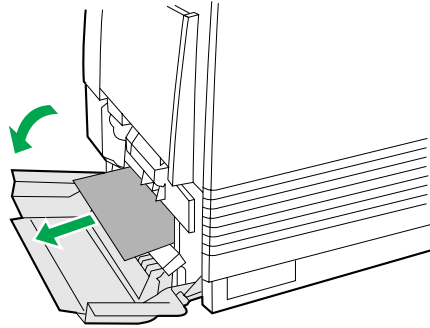

- 2** Close the left side door.
OR

- 1** Remove the media tray.

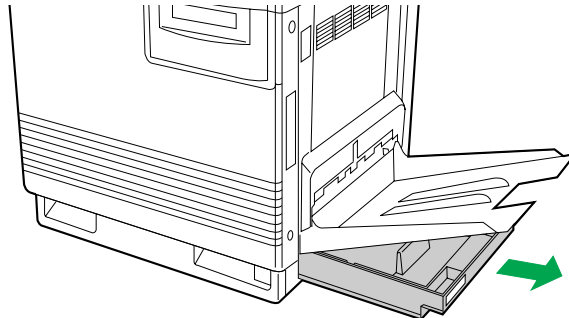

- 2** Remove the jammed media from inside the printer.

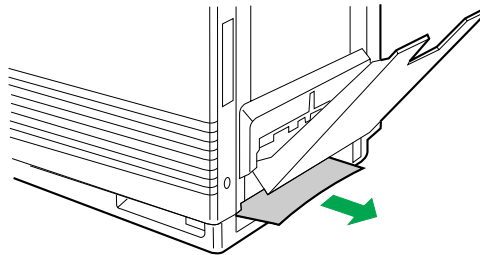

- 3** Reinsert the media tray.
- 4** **Open and close the printer's front door** to clear the error message from the printer LCD panel.

To clear media jams in location A with 2nd cassette feeder:

- 1** Open the lower left side door.

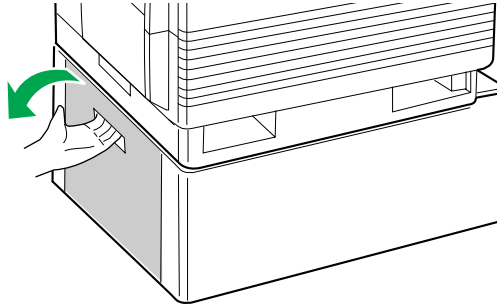

- 2** Remove the jammed media.

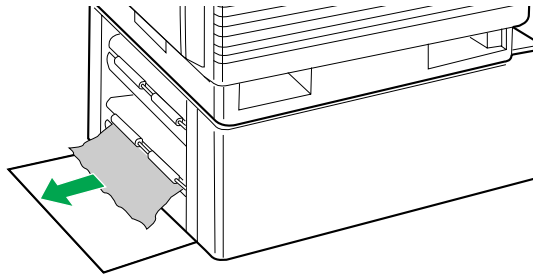

- 3** Close the lower left side door.
OR

- 1** Remove the selected media tray (middle or lower media tray).

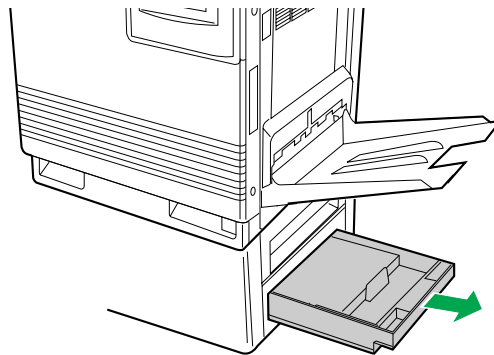

- 2 Remove the jammed media from inside the printer.

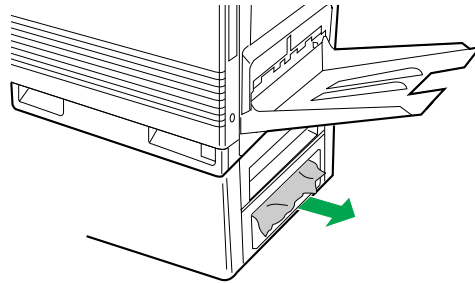

- 3 Reinsert the media tray.
- 4 **Open and close the printer's front door** to clear the error message from the printer LCD panel.

To clear media jams in location B with multi-purpose tray:

- 1 Remove the jammed media from the multi-purpose tray.

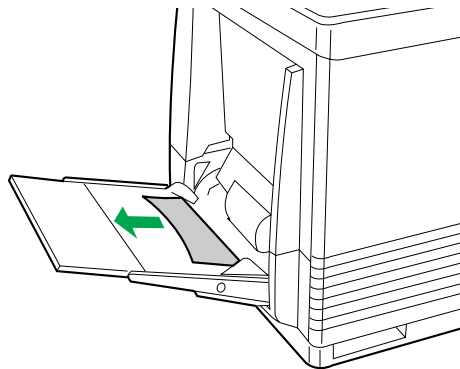

- 2 **Open and close the printer's front door** to clear the error message from the printer LCD panel.

NOTE:

- A few sheets of paper printed after cleaning media jam may be dirty.

To clear media jams in location B with media tray:

- 1** Open the left side door.

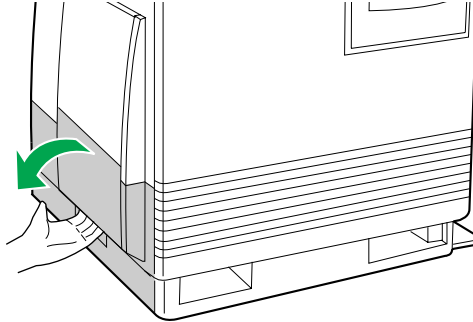

- 2** Use the green handles to pull out the paper feeder.

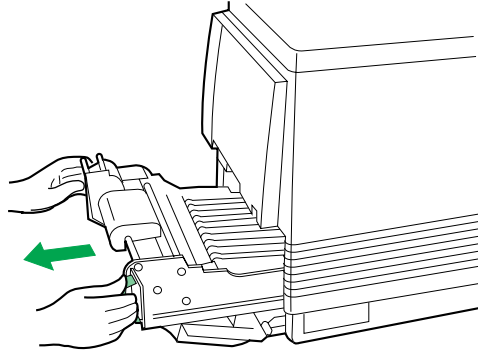

- 3** Remove the jammed media on or under the paper feeder.

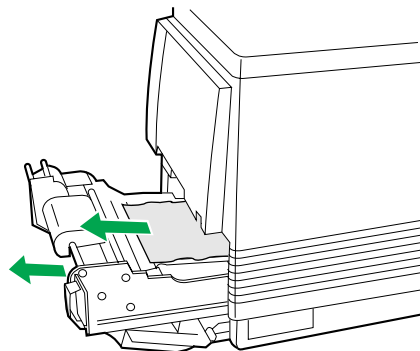

- 4** Reinsert the paper feeder and close the left side door.

To clear media jams in location C:

- 1 Open the printer's front door.

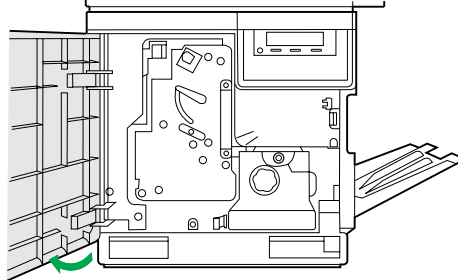

SAFETY CAUTION:



- The fuser is hot; to avoid personal injury, turn off the printer and wait 10 minutes (after opening the printer's front door) for the fuser to cool before touching it.

- 2 Check whether the media is jammed under the color imaging unit.

- If the media is jammed, remove it by following the steps 1 to 4 in "To clear media jams in location B with media tray" on [page 224](#) and then go to the next step.
- If it isn't, go to the next step.

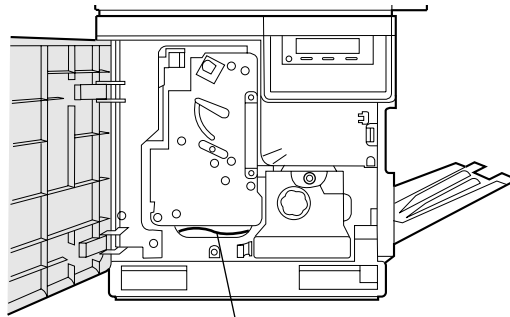

Jammed media

- 3 Turn the small green thumbscrew counterclockwise to unlock the fuser.

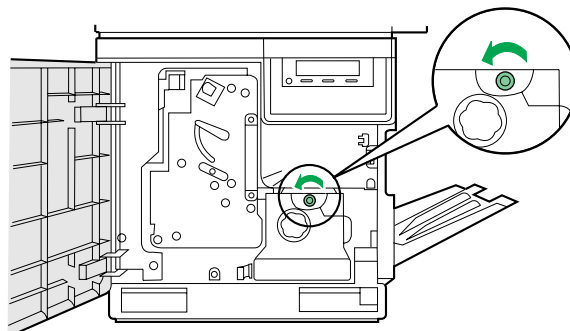

- 4**
- Holding the green tab on the right, slide the fuser out until it stops.
 - Press the green lever on the left to release the safety catch.

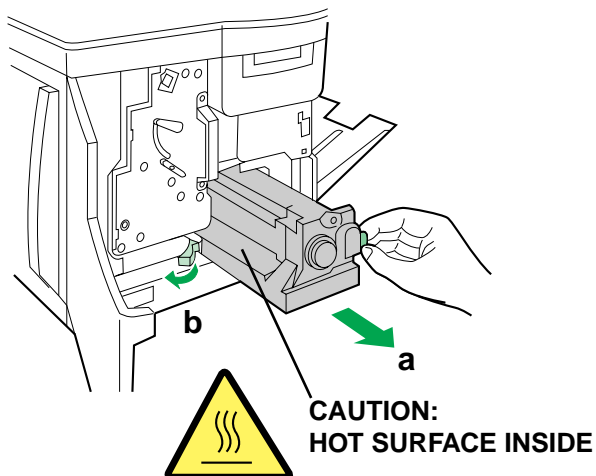

- 5**
- Hold the fuser as shown below, and slide it out of the printer.
 - Close the printer's front door.

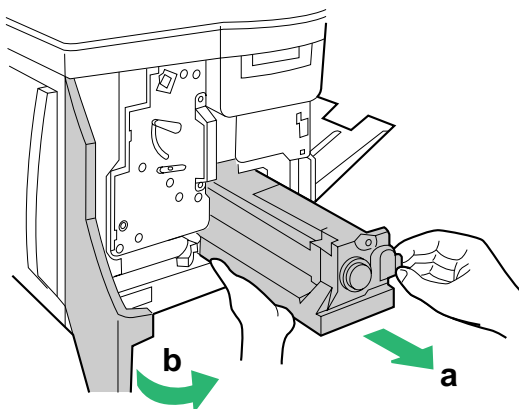

SAFETY CAUTIONS:



- The fuser unit weighs approximately 3.1 kg {6.8 lbs.}. Take care when handling it.
- Do not touch the roller and the parts around the roller when handling the fuser, because they may be hot.

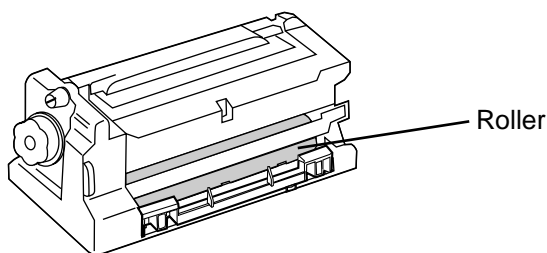

- 6** Remove the oil supply roll.
- a) Press out on tabs to unlock the oil supply roll.
 - b) Remove the oil supply roll out of the fuser.

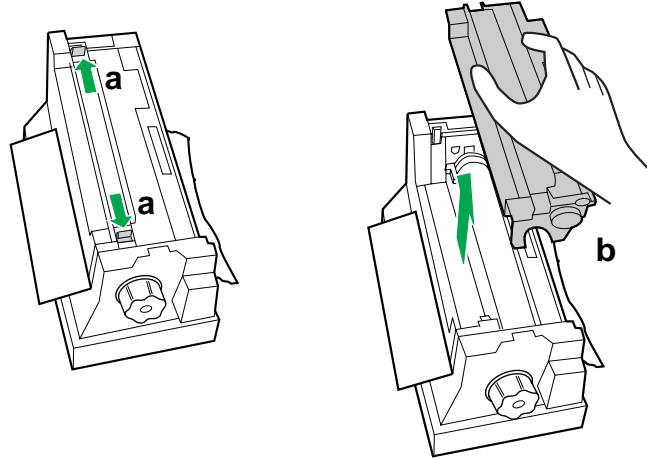

NOTE:

- If the paper is not jammed in the fuser unit, perform the following. Repeat steps 1 to 4 in “To clear media jams in location B with media tray” on [page 224](#).

- 7** Remove the cleaning pad, holding the tabs.

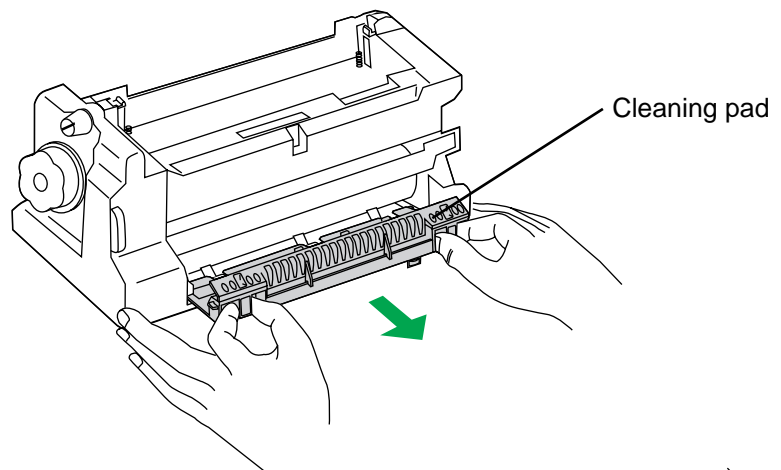

(The shape of a cleaning pad is subject to change.)

- 8** a) Turn the fuser's large green knob clockwise.
b) Remove the jammed media.

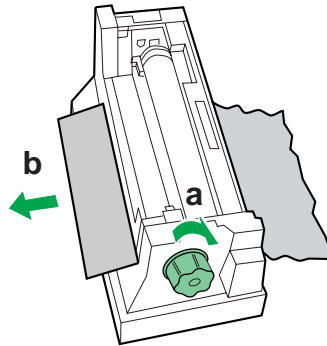

OR

Remove the jammed media.

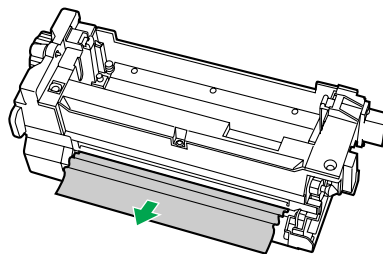

- 9** Replace the cleaning pad.

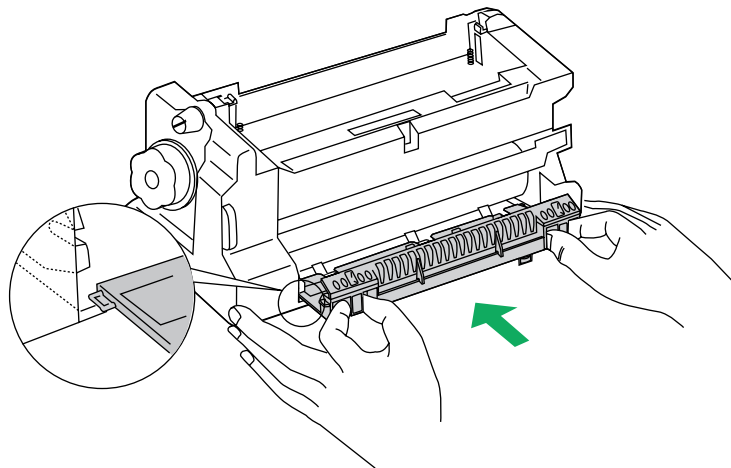

- 10** a) Replace the oil supply roll into the fuser.
b) Press down firmly on the oil supply roll to snap both sides into place.

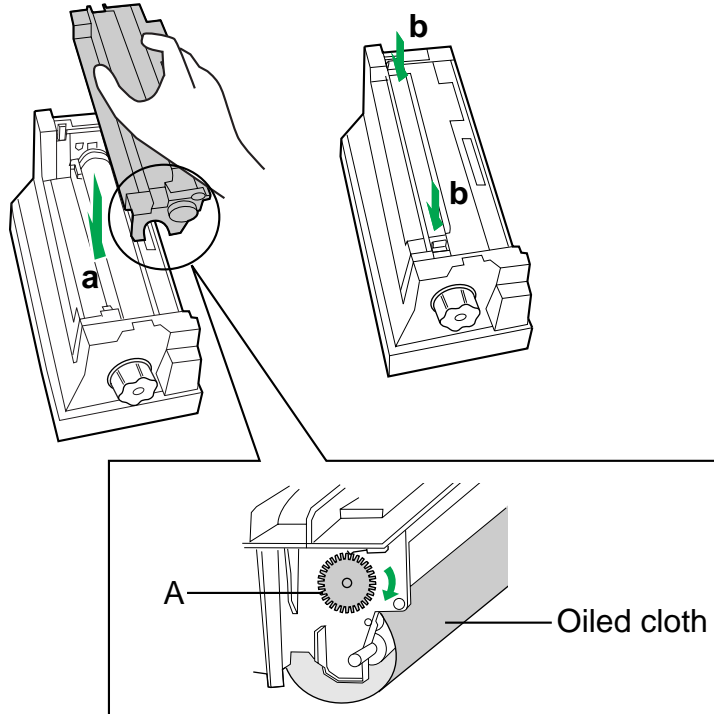

NOTE:

- If the oiled cloth is loose, rotate the gear (A) clockwise until it is tight. Do not touch the oiled cloth.

CAUTION:

- If the oil supply roll is not installed correctly, print quality will be diminished.

- 11** a) Open the printer's front door.
b) Slide the fuser back into the printer.

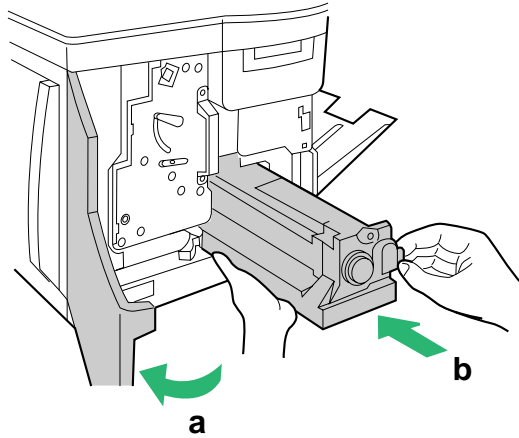

- 12** a) Turn the small green thumbscrew clockwise to lock the fuser.
b) Close the printer's front door.

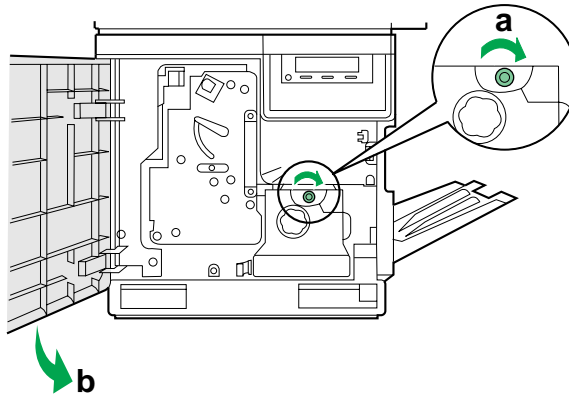

To clear media jams in location D with face down printing:



SAFETY CAUTION:

- The fuser is hot; to avoid personal injury, turn off the printer and wait 10 minutes (after opening the printer's front door) for the fuser to cool before touching it.

NOTE:

- First check the exit opening for media that has jammed and folded like an accordion. It is especially difficult to see if the media is transparency film.

- 1**
 - a) Open the printer's front door.
 - b) Pull open the access door (above the plastic output tray); see if the media is visible.

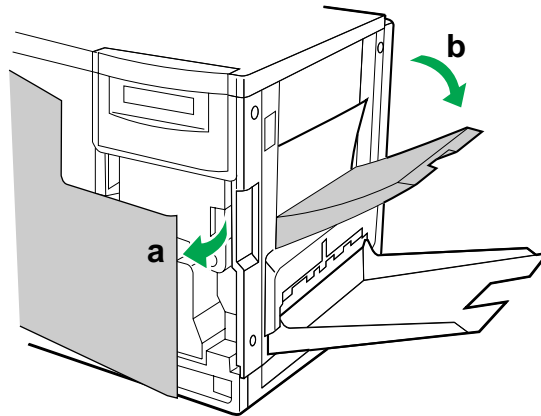

- 2**
 - a) Turn the large green knob on the fuser counterclockwise.
 - b) Remove the media from inside the access door.

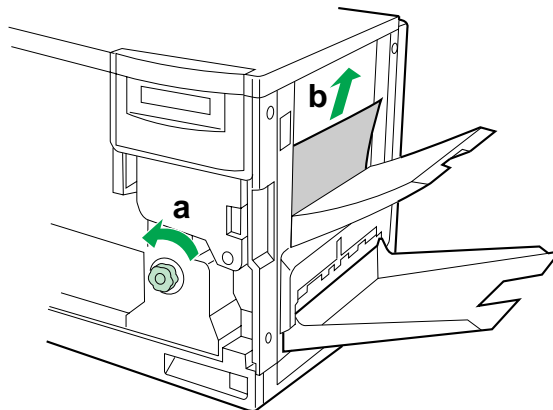

CAUTION:

- If the fuser knob will not turn, do not force it, or you may damage the fuser. Instead, follow these steps:
 - 1 Unlock the fuser by turning the small green thumbscrew counterclockwise.
 - 2 Pull the fuser out. The media will probably tear.
 - 3 Remove the oil supply roll.
 - 4 Turn the fuser's large green knob to release the jammed media.
 - 5 Remove the jammed media from the fuser and the printer.

SAFETY CAUTION:



- The fuser is hot; to avoid personal injury, turn off the printer and wait 10 minutes for the fuser to cool before touching it.

3

Close the printer's front door.

To clear media jams in location D with face up printing:

1

- a) Open the printer's front door and the right side door.
- b) Turn the fuser's large green knob counterclockwise to release the jammed media.
- c) Remove the jammed media from the right side of the printer.

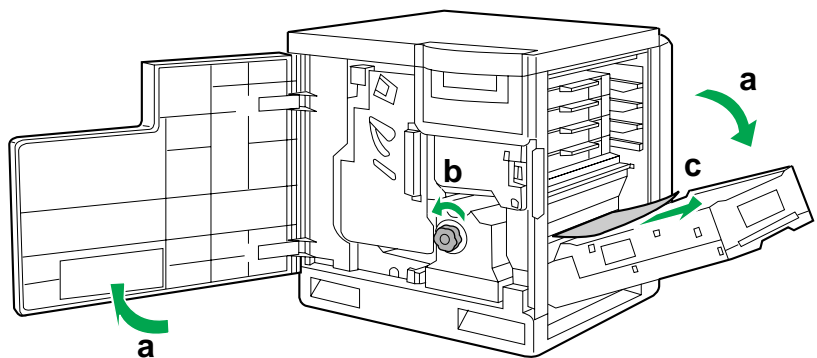

2

Close the printer's front door and the right side door.

To clear media jams in location E:

- 1** Remove the jammed media from the output tray.

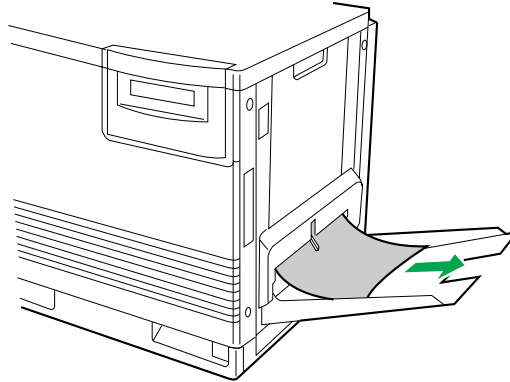

- 2** Open and close the printer's front door to clear the error message from the printer LCD panel.

To clear jams with the multi-purpose tray:

- 1** Remove the jammed media from the multi-purpose tray.

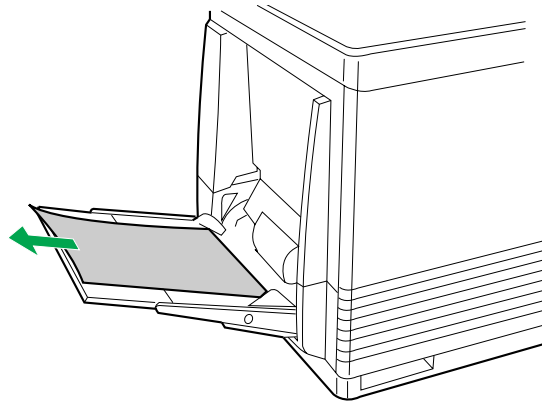

- 2** Open and close the printer's front door to clear the error message from the printer LCD panel.

Troubleshooting

Scanner

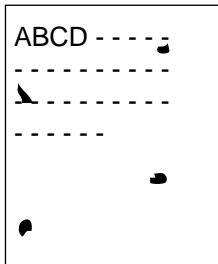
Trouble	Possible Cause	Corrective Action
Scanner does not turn on.	Power cord is not connected.	Connect the power cord.
Scanner Error 49 is displayed on the scanner LCD panel when powered on.	Scanner is locked.	Unlock the scanner.
Scanning operation cannot be performed.	SCSI cable is not properly connected.	Connect the SCSI cable.
	SCSI ID No. or terminator switch is not set correctly.	Set the SCSI ID No. or terminator switch correctly.
	SCSI-2 board is not compatible.	Use a recommended SCSI-2 board.
	Software may not be installed.	Install the software.
Scanned image is dirty. 	Original document is dirty.	Clean the document.
	Scanner glass is dirty.	Clean the scanner glass.
One or both ends of image is/are not scanned.	Document is not positioned correctly.	Reposition the document correctly according to the size.
Scanned image is blurred or partially colored.	Document is not evenly set on the scanner glass.	Set the document evenly.
Scan quality is bad.	You may not be using the software utility correctly.	Consult the <i>Utilities and Drivers Reference Guide</i> .
	Condensation has occurred.	Leave the unit for 4 or 5 hours.

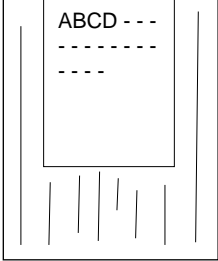
Trouble	Possible Cause	Corrective Action
ADF doesn't feed document.	Document thickness is out of specifications.	Scan the document by placing it on the scanner glass.
	Too many documents are inserted in the ADF tray.	The height of document should not exceed the limit mark on the document guide.
<p>Scanned image has vertical lines when a document is scanned using the ADF.</p> 	ADF scanner glass or white sheet is dirty.	Clean the ADF scanner glass and white sheet.
Scanned image is skewed when a document is scanned using the ADF.	Document guides are not adjusted correctly.	Adjust the guides according to the width of the document.
Scanned image is blank when a document is scanned using the ADF.	Document is inserted face down.	Insert the document face up.
Service Error is displayed on the scanner LCD panel.	An internal error has occurred.	Turn the scanner off and on 2-3 times. If the error persists, call for service.

Printer

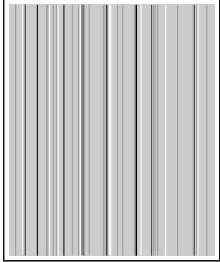
Trouble	Possible Cause	Corrective Action
READY indicator is blinking.	The printer is receiving, processing or printing job.	Wait for the job to be completed or cancel the job.
	You have entered the Menu mode in the printer panel.	Exit the Menu mode by pressing the MENU/EXIT button.
	The printer is networked and WebTools are being accessed.	Wait for the job to be completed.
READY indicator is off.	The printer is not ready, is disabled, or has detected an error.	Read the printer panel message to determine the printer status.
ERROR indicator is on.	Error occurred that is not user-correctable.	Turn the printer off and back on again. If the indicator is still on, the printer requires service.
ERROR indicator is blinking.	The printer has stopped because it detected a user-correctable error such as an open door or a media jam.	Correct the condition displayed on the printer panel (e.g., close the door or clear the media jam).
<p>A single color is not uniform or many vertical streaks (both light and dark) of slightly different density and non-uniform color.</p> 	The toner is almost depleted.	Replace the toner cartridge.

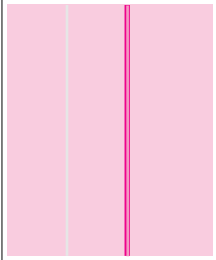
Trouble	Possible Cause	Corrective Action
<p>Half tone area has areas of weak color.</p> 	<p>Paper doesn't match the environmental conditions, or it has too much moisture.</p>	<p>Try fresh paper, or another type of paper.</p> <p>Store media in the original, dust-free package in the same environmental conditions as the printer.</p>
<p>A single color appears faded.</p>	<p>The color density is set incorrectly in the printer panel.</p> <p>The toner is almost depleted.</p>	<p>See Chapter 7 "Color Calibration".</p> <p>Replace the toner cartridge soon (depending on the complexity of your prints, you can continue to print up to 100 more pages).</p>
<p>A single color has a sharp, dark or light vertical streak.</p> 	<p>The toner cartridge is almost depleted and is not properly applying toner.</p>	<p>Replace the toner cartridge.</p>

Care and Maintenance

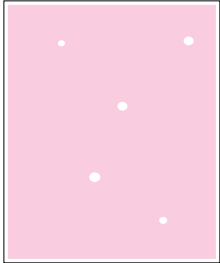
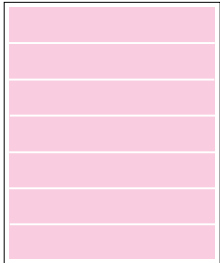
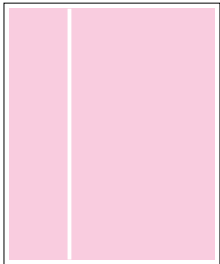
Trouble	Possible Cause	Corrective Action
<p>Small white spots appear on OHP transparency.</p> 	<p>OHP transparency has dust on its surface.</p>	<p>Remove dust or stain from OHP transparency.</p>
<p>A single color shows a light, repeating horizontal line.</p> 	<p>The roller in the toner cartridge has a slight impression after a long period of storage.</p>	<p>Run 20-30 prints. The impression will disappear with continued time and use.</p>
<p>Prints are missing fine-line detail.</p>	<p>The color imaging unit has reached its useful life.</p>	<p>Replace the color imaging unit.</p>
<p>Dark color spots and dark or light streaks appear in all colors.</p>	<p>The color imaging unit has reached its useful life.</p>	<p>Replace the color imaging unit.</p>
<p>Straight, thin light vertical line in colors.</p> 	<p>The photosensitive belt inside the color imaging unit is scratched.</p>	<p>Replace the color imaging unit.</p>

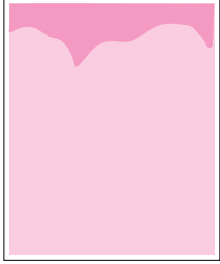
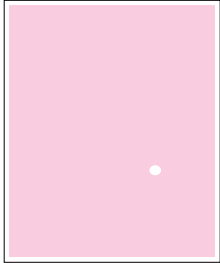
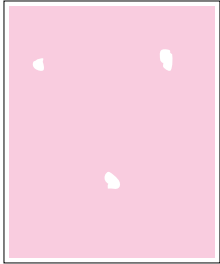
Trouble	Possible Cause	Corrective Action
<p>Each color “bleeds” into the color band.</p> 	<p>The color imaging unit's internal waste toner box is full.</p>	<p>Replace the color imaging unit.</p>
<p>A single white spot appears in approximately the same vertical place on the page.</p> 	<p>The color imaging unit is damaged.</p>	<p>Replace the color imaging unit.</p>
<p>Large light spot(s) appear randomly.</p> 	<p>Fingerprint(s) on the underside belt or photosensitive belt (inside) of the color imaging unit.</p>	<p>Print several pages until the spots fade.</p>

Care and Maintenance

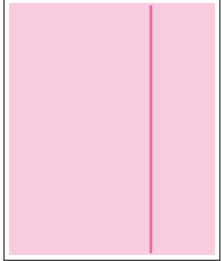
Trouble	Possible Cause	Corrective Action
<p>One or more dark vertical lines appear on the print in all colors.</p> 	<p>The color imaging unit is scratched.</p>	<p>Replace the color imaging unit; make sure that the old color imaging unit is not exposed to light for more than 45 seconds. If a new color imaging unit does not correct the problem:</p> <ul style="list-style-type: none"> • Put the old color imaging unit back into the printer. • Repack the new color imaging unit.
	<p>The fuser is damaged.</p>	<p>Replace the fuser.</p>
<p>A piece of the printed image is missing and reappears out of place, approximately 129 mm (5") down the page.</p>	<p>The fuser's internal roller is not being consistently oiled or the fuser's internal roller is contaminated with toner particles.</p>	<p>Print 5-10 pages of blank pages to clean the roller. If you still see the problem:</p> <ul style="list-style-type: none"> • Replace the oil supply roll. <p>If you still see the problem:</p> <ul style="list-style-type: none"> • Replace the fuser.
<p>The surface of the printed image appears to have vertical scratches (visible by holding the print at an angle and observing the "shine" of the image). At first, the scratches appear only on the printed image; eventually, dark vertical scratches appear on the imprinted portion of the page.</p>	<p>The fuser is near its useful life.</p>	<p>Replace the fuser (depending on your quality needs, you can continue to print until the dark vertical lines appear).</p>
<p>Media frequently wraps around the fuser.</p>	<p>The oil supply roll has reached its useful life.</p>	<p>Replace the oil supply roll.</p>

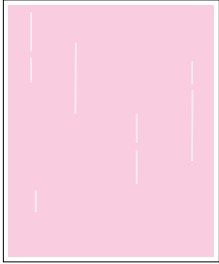
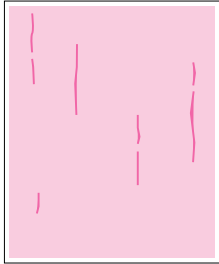
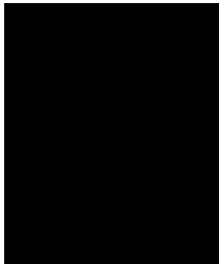
Trouble	Possible Cause	Corrective Action
<p>Light vertical streaks appear in all colors.</p> 	<p>The main charge grid is dirty.</p>	<p>Replace the color imaging unit.</p>
<p>Dark and wavy vertical streaks appear in all colors.</p> 	<p>The main charge grid is dirty.</p>	<p>Replace the color imaging unit.</p>
<p>The entire page prints in black, including the borders.</p> 	<p>Bad electrical contact for the main charge grid.</p>	<p>Reinsert the color imaging unit to correct the contact for the main charge grid.</p>
	<p>The main charge grid is broken.</p>	<p>Replace the color imaging unit.</p>
<p>Toner spots appear on the back of the media.</p>	<p>The transfer unit is worn out.</p>	<p>Replace the transfer unit.</p>

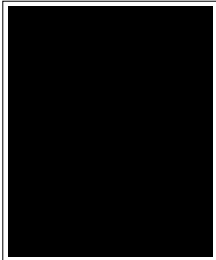
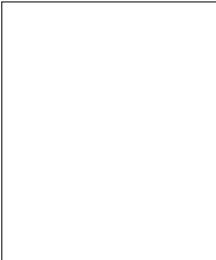
Trouble	Possible Cause	Corrective Action
<p>The page prints in black in the image area only. (The borders are clear.)</p> 	<p>Either the image processor board or engine control board is not functioning properly.</p>	<p>Turn the printer off and back on again. If the problem persists, call for service on your printer.</p>
<p>The page is completely blank.</p> 	<p>The problem could be with one of the following:</p> <ul style="list-style-type: none"> • Engine control board. • Developer voltage. • Laser scanning unit mirror. 	<p>Turn the printer off and back on again. If the problem persists, call for service on your printer.</p>
<p>"Call for Service" is displayed on the printer LCD panel.</p>	<p>An error occurred that is not user-correctable.</p>	<p>Turn the printer off and back on again. If the error persists, call for service.</p>

If you can't make a print:

Trouble	Corrective Action
<p>Printer not operating.</p>	<p>Make sure that you plugged in the printer and turned it on.</p>
	<p>Make sure that you connected the interface cable(s) properly.</p>
<p>More info to come for these messages.</p>	<p>If the communication link between your computer and the printer is working but the printer ejects a blank page when printing from your application or through Windows. Make sure that the appropriate driver is installed and that you have selected the printer correctly.</p>

Trouble	Possible Cause	Corrective Action
The setting for printing is not effective.	Some applications may not allow you to change the settings through the KX-PS8100 printer driver's setting window.	Change the application's settings.

If you can't make a duplicate:

Trouble	Corrective Action
You cannot duplicate using the scanner panel when Macintosh 7500/7600/8500/9500, the scanner and the printer are connected using the SCSI cables.	<p>Make sure that the computer is turned ON.</p> <p>Disconnect KX-PS8100 from the computer and change the terminator setting accordingly. (See page 66.)</p>

Media problems

Trouble	Corrective Action
Frequent paper-picking errors.	Fan the paper or transparencies before installing them in their respective trays; this is especially important for transparencies because they tend to stick together.
	Make sure that you have loaded paper in the paper tray and transparencies in the transparency tray.
	Make sure that the media is installed under the hooks at the front of the media tray.
	If printing on transparencies and your printer has a 2nd cassette feeder, make sure that the transparency tray is installed in the upper or middle tray slot.
	Clean the paper-pick rollers. (See page 211 for directions.)

Trouble	Corrective Action
Frequent media jams.	Make sure that you use a high-quality laser paper: 60–105 g/m ² (16-28 lbs.) paper in the media trays and 75–165 g/m ² (20–44 lbs.) paper in the multi-purpose tray.
	If you are using media that is 105 g/m ² (28 lbs.), check if the Face Down media output setting is selected in the driver. If it is, change the setting to Face Up.
	Use only recommended transparencies. (See page 293.) We cannot guarantee the results of other transparencies.
	Make sure that the media is installed under the hooks at the front of the media tray.
	Do not overfill the media tray, as indicated by the red line on the right side of the tray.
	Clean the paper-pick rollers. (See page 211 for directions.)
	Make sure that the media thickness switch is set correctly for the installed media. (See page 52.)
Frequent media jams at C	The cleaning pad may get dirty with toner. Replace the cleaning pad. (See page 227 and see page 197 of <i>Setup Manual</i> .)

Problems with image size and position

Trouble	Corrective Action
Off-set images.	Check your application for correct image sizing.
Cut-off images.	Check your application for image sizing.
	Make sure that the correct size media is in the media tray.

Print quality problems

Trouble	Corrective Action
Prints have dull, faded colors.	Adjust or calibrate colors. See Chapter 7 “Color Calibration” .
	Make sure that the color imaging unit stays covered until immediately before installing it in the printer. Exposure to light for more than 45 seconds can damage the color imaging unit.
	Make sure that the toner cartridges are installed correctly.
	Make sure that you use a high-quality laser paper: 60–105 g/m ² (16-28 lbs.) paper in the media trays and 75–165 g/m ² (20–44 lbs.) paper in the multi-purpose tray.
Image is very faded or pieces of the image are missing; toner on the page is loose.	When using the multi-purpose tray, make sure that you have selected the correct media type in the driver or in the Menu mode of the printer panel.
Streaks or spots	Most spots are caused by fingerprints or dust introduced into the printer while installing the color imaging unit or loading media. Make sure that the surface where you unpack the color imaging unit, paper, and transparencies is free of dust. Keep supplies in a covered area or a closed box.
	Make sure that the color imaging unit stays covered until immediately before installing it in the printer. Exposure to light can damage the color imaging unit and will produce light streaks or faded prints.
	Do not touch the right side or underside of the color imaging unit; fingerprints affect print quality.
	Make sure that the paper or transparency film is clean.
	Make sure that you handle the media on the outside edges to avoid fingerprints.
	To get rid of fingerprint spots, print a few prints.

Trouble	Corrective Action
The back of the printed page appears dirty.	Toner particles have contaminated the transfer roller. This can happen if the printed image is larger than the media (for example, when printing on envelopes). Run 10-20 prints to clean the transfer roller.
	The cleaning pad may get dirty with toner. Replace the cleaning pad. (See page 227 and see page 197 of <i>Setup Manual</i> .)
The print quality of a transparency is poor.	Make sure that you have selected the correct media.
	Make sure that you are using the recommended media (CG3710).
	Make sure that you are printing on the taped side, if you are using CG3710.

LCD panel messages

When an error interferes with printing (or) scanning, you will see a message on the LCD panel. The following table lists the messages in alphabetical order, with the appropriate corrective action for each one.

The following status messages cause the ERROR indicator to blink. Scanning/printing will continue when corrective action (if required) is taken, and the READY indicator is lit.

NOTE:

- If the message indicates that you don't have enough memory to finish duplicating or printing, you may need to install additional memory to handle your workload. See "Installing additional memory" on page 278.

Scanner LCD panel

Message	Corrective Action/Additional Information
ADF open. Close the ADF.	ADF is open. Close the ADF.
ADF paper Jam.	A jam has occurred in ADF. Open the ADF top cover, remove the jammed document.

Message	Corrective Action/Additional Information
ADF top cover open. Close the ADF top cover.	ADF top cover is open. Close the ADF top cover.
Memory OverFlow Add SDRAM to Printer	Print memory is not enough for duplicating. Press the RESET/STOP button to return to "Ready". Add memory to printer.
Memory OverFlow Select Lower Quality	Print memory is not enough for duplicating. Press the RESET/STOP button to return to "Ready". Select a lower quality.
No detection marker in ADF	The white sheet is dirty. Clean the white sheet.
Remove document from ADF tray.	A document is placed in the ADF tray when power is turned on. Remove the document from the ADF tray.
	A document is placed in the ADF tray when a jam is cleared. Remove the document from the ADF tray.
SCSI error	Communication cannot be established between the scanner and printer. Connect the SCSI cable correctly. or Make sure that the computer connected with the SCSI cable is turned on.
Saving	Scanner is saving the data using DataSave function.
Loading	Scanner is loading the data using DataLoad function.

Printer LCD panel

Message	Corrective Action/Additional Information
%s%s.%s Error DIMM Slot %s	Cycle Power. If printer does not function normally, call for service.
Black Toner Empty	Replace black toner.
Black Toner Cartridge Not installed	Install black toner cartridge.
Canceling Job	When the ◀/CANCEL button is pressed, the job currently being processed is deleted.
Cannot recover from JAM Press Enter	Semi Automatic duplex is aborted by jam.
Charger Not installed	Install the charger unit.
Controller Memory Error Cycle Power	Cycle Power. If printer does not function normally, call for service.
Cyan Toner Empty	Replace cyan toner.
Cyan Toner Cartridge Not installed	Install cyan toner cartridge.
DC Controller Malfunction	Cycle Power. If the printer does not function normally, call for service.
Disk Device Failure	Cycle Power. If printer does not function normally, call for service.
Disk File Operation Failed	Hard disk is functioning abnormally. Cycle Power. If printer does not function normally, call for service.
Disk Is Full	Erase or replace the printer's hard disk. Execute the Reset Queues menu from the printer panel. See "Reset Queues" on page 150.
Engine Interface Error Cycle Power	Cycle Power. If printer does not function normally, call for service.
Error %s Cycle Power	Unrecoverable error happened. Turn off the printer.

Message	Corrective Action/Additional Information
Flash Device Failure	Flash DIMM hardware error. Cycle Power. If printer does not function normally, call for service.
Flash File Operation Failed	Flash DIMM is functioning abnormally. Cycle Power. If printer does not function normally, call for service.
Front or Right door Open	Close Front or Right door.
Fuser Unit Not installed	Install a Panasonic fuser unit.
Fuser Unit wearing out*	Fuser unit will need to be replaced soon.
Fuser Unit Worn out	Replace the fuser unit.
Imaging Unit No tension	Set the upper lever of the color imaging unit to "Lock".
Imaging Unit Not installed	Install color imaging unit.
Imaging Unit wearing out	Color imaging unit will need to be replaced soon.
Imaging Unit Worn out	Replace the color imaging unit.
Initializing	Printer is initializing.
Insert printed pages in MP tray, press Continue	Insert printed pages into multi-purpose (MP) tray, then press the ▲/CONTINUE button.
Insufficient Memory	Not enough memory to finish printing. Change printing resolution to 600 x 600 dpi if you selected higher resolution. or Install additional memory in the printer.
Jam at A See front door label	Clear paper jam. See printer's front door label. (See page 221.)
Jam at B See front door label	Clear paper jam. See printer's front door label. (See page 223.)

* Printing a large quantity of pages with high coverage will result in the message "Fuser Unit wearing out" to be displayed earlier than its expected life. In this case, replace the fuser unit.

Care and Maintenance

Message	Corrective Action/Additional Information
Jam at C See front door label	Clear paper jam. See printer's front door label. (See page 225.)
Jam at D See front door label	Clear paper jam. See printer's front door label. (See page 231.)
Jam at E See front door label	Clear paper jam. See printer's front door label. (See page 233.)
Jam at MPT	Clear paper jam. See printer's front door label. (See page 233.)
Left side door Open	Close Standard Cassette side door.
Load A4	Load A4 size paper.
Load A4 in Lower tray	Load A4 size paper in Lower tray.
Load A4 in Middle tray	Load A4 size paper in Middle tray.
Load A4 in Upper tray	Load A4 size paper in Upper tray.
Load Legal	Load legal size paper.
Load Legal in Lower tray	Load legal size paper in Lower tray.
Load Legal in Middle tray	Load legal size paper in Middle tray.
Load Legal in Upper tray	Load legal size paper in Upper tray.
Load Letter	Load letter size paper.
Load Letter in Lower tray	Load letter size paper in Lower tray.
Load Letter in Middle tray	Load letter size paper in Middle tray.
Load Letter in Upper tray	Load letter size paper in Upper tray.
Low Black Toner	Black toner will need to be replaced soon.
Low Cyan Toner	Cyan toner will need to be replaced soon.
Low Magenta Toner	Magenta toner will need to be replaced soon.

Message	Corrective Action/Additional Information
Low Yellow Toner	Yellow toner will need to be replaced soon.
Lower Left side door Open	Close Optional Cassette side door.
Lower Tray Empty	Add media to Lower tray.
Lower Tray Not installed	Install Lower tray.
Magenta Toner Empty	Replace magenta toner.
Magenta Toner Cartridge Not installed	Install magenta toner cartridge.
Media Tray Empty	Add media to media tray.
Media Tray Not installed	Install media tray.
Memory Error 0	Cycle Power.
Memory Error 1	Cycle Power.
Memory Error 2	Cycle Power.
Memory Error 3	Cycle Power.
Memory Error 4	Cycle Power.
Memory Error 5	Cycle Power.
Memory Error 6	Cycle Power.
Memory Error 7	Cycle Power.
Memory Error 8	Cycle Power.
Memory Shortage Page Simplified	Not enough memory to finish printing. Change printing resolution to 600 x 600 dpi if you selected higher resolution. or Install additional memory in the printer.
Middle Tray Empty	Add media to Middle tray.
Middle Tray Not installed	Install Middle tray.

Care and Maintenance

Message	Corrective Action/Additional Information
Multi-Purpose Tray Empty	Add media to multi-purpose tray.
NVRAM Error Settings Changed	NVRAM hardware error. Cycle Power. If printer does not function normally, call for service.
NVRAM Full Settings Lost	Hardware error of Flash DIMM. Cycle Power. If printer does not function normally, call for service.
Oil Roll Not installed	Install oil web unit.
Oil Roll wearing out	Oil supply roll will need to be replaced soon.
Oil Roll Worn out	Replace the oil web unit.
Out of Memory Job Cleared	Not enough memory to finish printing. Change printing resolution to 600 x 600 dpi if you selected higher resolution. or Install additional memory in the printer.
Out of Memory Job Failed	Not enough memory to finish printing. Change printing resolution to 600 x 600 dpi if you selected higher resolution. or Install additional memory in the printer.
Output Tray Full	Remove media from Output tray.
Page Too complex	Not enough memory to finish printing. Change printing resolution to 600 x 600 dpi if you selected higher resolution. or Install additional memory in the printer.
Paper Feeder Not installed	Install paper feeder.
Parallel I/O Buffer Overflow	Not enough memory to finish printing.
PJL Operations Failed	Error in PJL code. Resend print job to the printer.

Message	Corrective Action/Additional Information
Press Enter to Initialize Disk	Press the ENTER button to initialize a new hard disk. This message will also appear if the hard disk has malfunctioned, or if the hard disk is the incorrect type. If this error appears after cycling power to the printer, contact an authorized service representative.
Printing Configuration	Printer is printing the Configuration page.
Printing Font List	Printer is printing the Font List page.
Printing Test Page	Printer is printing the Test Page.
Processing	Printer is receiving or processing a print job.
PS Memory Full	Not enough memory to finish printing. Change printing resolution to 600 x 600 dpi if you selected higher resolution. or Install additional memory in the printer.
PS Memory Full Stored Data Lost	Not enough memory to finish printing. Change printing resolution to 600 x 600 dpi if you selected higher resolution. or Install additional memory in the printer.
RAM Test Failure Cycle Power	Cycle Power. If printer does not function normally, call for service.
Scan Buffer Error Cycle Power	Cycle Power. If printer does not function normally, call for service.
Service (%s) Cycle Power	Firmware error. Contact an authorized service representative.
TEST FAILED UP/DOWN CANCEL	Initial hardware test failed. Call for service.
Transfer wearing out	Transfer unit will need to be replaced soon.
Transparency Tray Not installed	Install transparency tray.
Upper Left side door Open	Close Left side door.

Message	Corrective Action/Additional Information
Upper Tray Empty	Add media to Upper tray.
Upper Tray Not installed	Install Upper tray.
Warming Up	Printer is warming up.
Yellow Toner Empty	Replace yellow toner.
Yellow Toner Cartridge Not installed	Install yellow toner cartridge.

LCD panel service calls

Some operation errors cause the ERROR indicator to blink and printing to stop. A message will be displayed on the LCD panel until the problem is fixed. If the LCD panel message includes the instruction, Call for Service, contact an authorized service representative.

In addition, if the following conditions occur, turn off and unplug the printer and scanner from the outlet and contact a qualified service representative:

- The power cord or plug is damaged or frayed.
- Liquid has been spilled into the printer.
- The printer and scanner have been exposed to rain or water.
- The printer and scanner do not operate normally though the operating instructions are being followed. Adjust only those controls that are described in the operating instructions; improper adjustment of other controls may result in damage and will often require extensive work to restore the printer and scanner to normal operation.

Status display program for Windows

The Status Display program is not available in Macintosh computers.

The Status Display program alerts the user to any errors. It displays an error message, identifies the problem area on the printer/scanner, and provides information regarding corrective action.

■ For Windows 3.1 users

When Windows 3.1 is started, the Panasonic Printer/Scanner Status icon appears and stays on the screen. This enables you to display the printer's/scanner's status at any stage during operation.

The Panasonic Printer/Scanner Status window appears when:

- A SCSI device error is found while using the printer driver, scanner driver (16 bit) or the digital duplicator utility

This window reduces to an icon when:

- The printer/scanner recovers from an error situation

If you have selected the "When device error" option in the Start Up box of the Setup for Status Display window:

- The Panasonic Printer/Scanner Status icon does not appear when Windows 3.1 is started
- The Panasonic Printer/Scanner Status window disappears after recovering from an error situation

NOTE:

- The Setup for Status Display window can be displayed by double clicking the Status display setup icon. In this window you can display the Start Up box by clicking the Start Up tab.

■ For Windows 95/Windows 98/Windows NT 4.0 users

The Panasonic Printer/Scanner Status window appears when:

- A SCSI device error is found while using the printer driver, scanner driver (16 bit or 32 bit), or the digital duplicator utility

This window disappears when:

- The printer/scanner recovers from an error situation

Scanner Status window

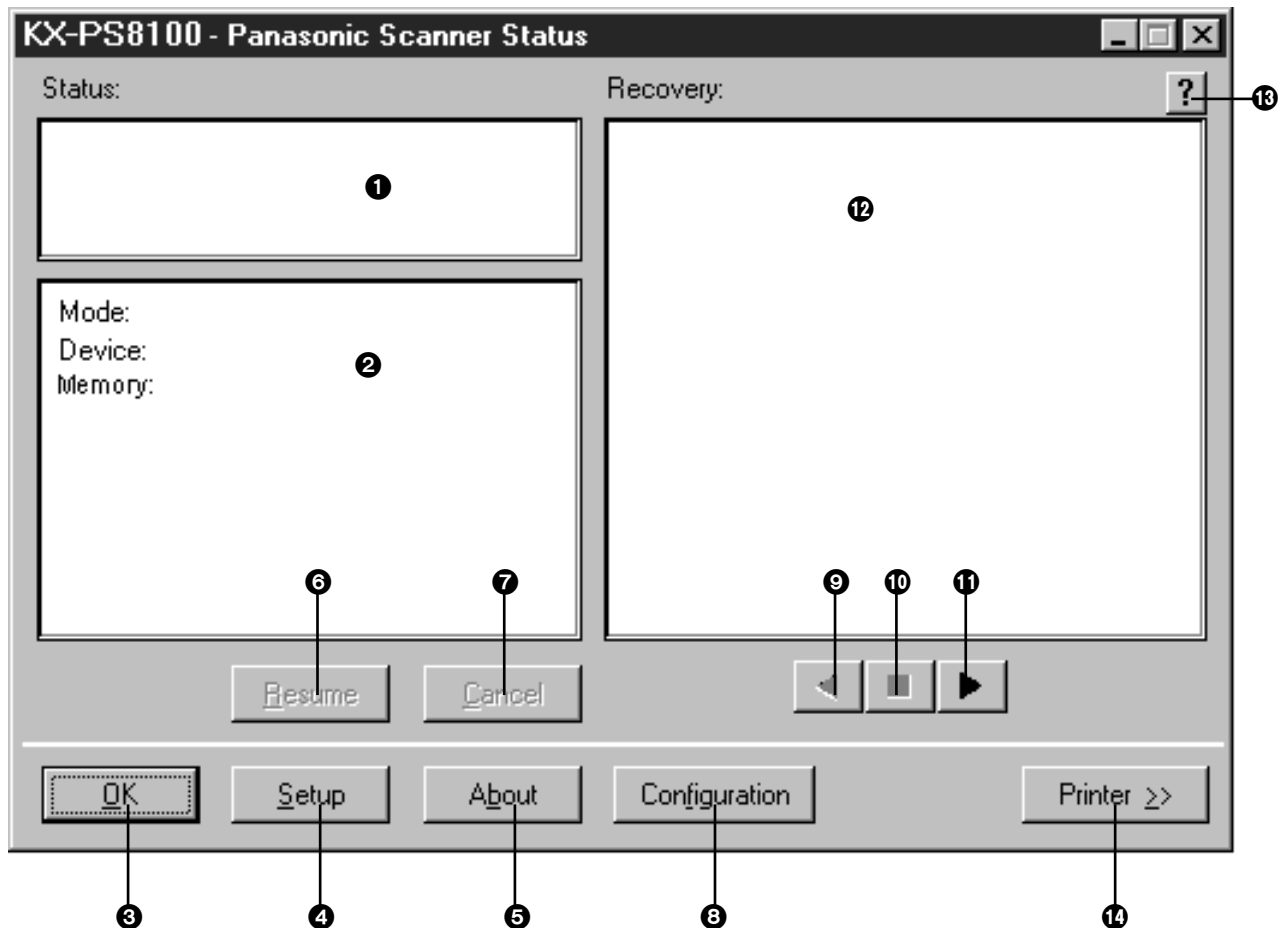

- ❶ This box shows an error or status message and the corresponding icon.
- ❷ This box lists the mode your scanner is in, device name (scanner), the built-in memory size of the printer, and the name of the scan job.
- ❸ This button minimizes the Panasonic Scanner Display window. Pressing the **Esc** key on the keyboard can also minimize it.
- ❹ This button displays the Status Display Setup window, where you can change different settings.
- ❺ This button displays the version of the Status Display.
- ❻ This button resumes scanning after recovering from an error situation.
- ❼ This button cancels the scan job which caused an error.

- ⑧ This button displays the Panasonic Show configuration window.
- ⑨ This button displays the previous recovery message.
- ⑩ This button displays the initial recovery message.
- ⑪ This button displays the next recovery message.
- ⑫ This box displays a recovery procedure along with a picture.
- ⑬ This button provides you additional help.
- ⑭ This button changes the Panasonic Scanner Status window to the Panasonic Printer Status window, and is displayed only when using the Digital Duplicator Utility.

Printer Status window

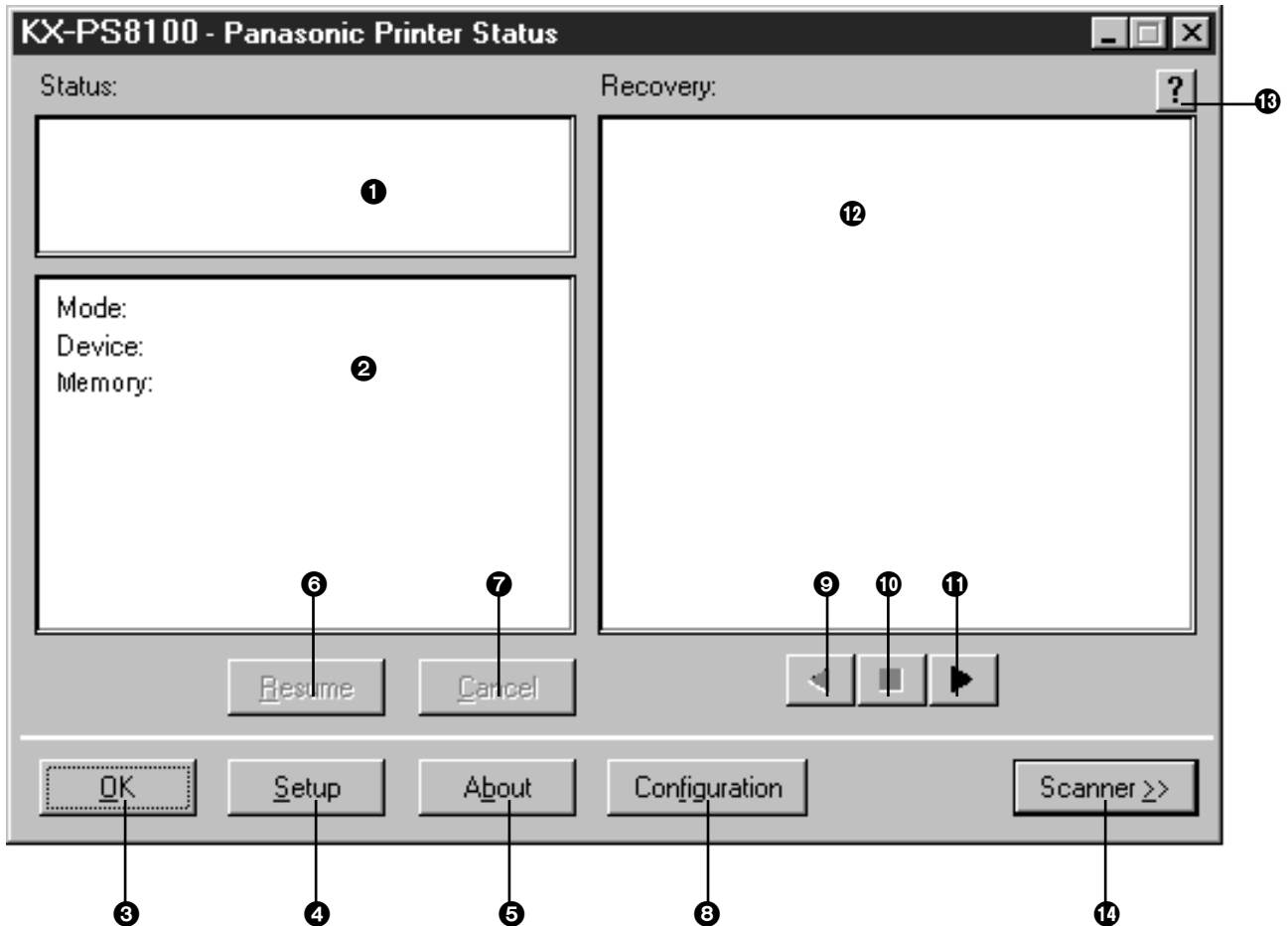

- ❶ This box shows an error or status message and the corresponding icon.
- ❷ This box lists the mode your printer is in, device name (printer), tray being used, the built-in memory size of the printer and the name of the print job.
- ❸ This button minimizes the Panasonic Printer Status window. Pressing the **Esc** key on the keyboard can also minimize it.
- ❹ This button displays the Setup for Status Display window, where you can change different settings.
- ❺ This button displays the version of the Status Display.
- ❻ This button resumes printing after recovering from an error situation.

- 7 This button cancels the print job which caused an error.
- 8 This button displays the Panasonic Show Configuration window.
- 9 This button displays the previous recovery message.
- 10 This button displays the initial recovery message.
- 11 This button displays the next recovery message.
- 12 This box displays a recovery procedure along with a picture.
- 13 This button provides you additional help.
- 14 This button changes the Panasonic Printer Status window to the Panasonic Scanner Status window, and is displayed only when using the Digital Duplicator Utility.

Repacking

It is highly recommended that you keep the original carton and ALL packing materials. Should you need to transport or ship your unit, please follow these instructions.

SAFETY CAUTIONS:



- The printer weighs about 49.5 kg {108.9 lbs.}. It must be handled by two people.
- The scanner weighs about 22.5 kg {49.5 lbs.}. It must be handled by two people.

NOTES:

- Should you need to send your KX-PS8100 for service, consult your reseller first or Panasonic.
- Please use the original carton and all of the original packing materials.
- If you do not have the packing for the color imaging unit and the transfer unit: contact Panasonic for packaging.
- Improper repacking of the KX-PS8100 may result in a service charge to remove spilled toner.
- Since the printer uses dry toner, extreme care must be taken when handling. The printer should be handled in the upright (vertical) position.

Material required:

- Original cartons and packing materials
- Newspaper or drop cloth
- Shipping tape and scissors

Packing the scanner

To prepare the scanner for repacking:

- 1** Turn off the scanner; remove the power cord and all interface cables.
- 2** Unplug the ADF cable.

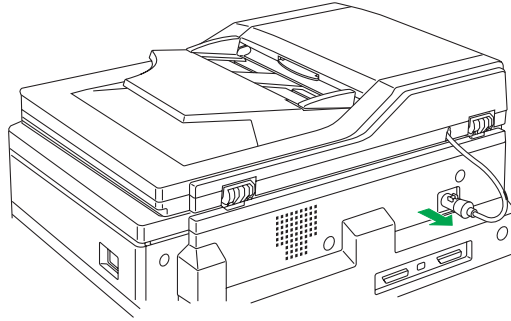

- 3** Open the ADF and remove it from the scanner bed by lifting it up.

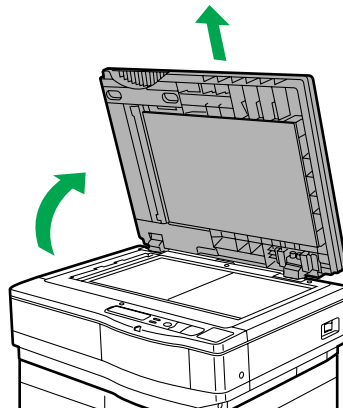

- 4** a) If the scanner is installed on the top of the printer, unlock the scanner by sliding it toward the left.

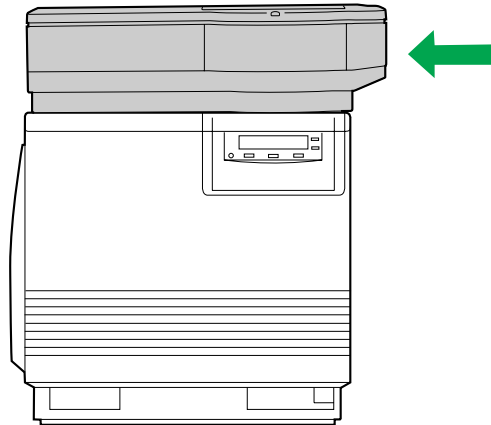

- b) Gently raise and remove the scanner by releasing it from the guide pins.

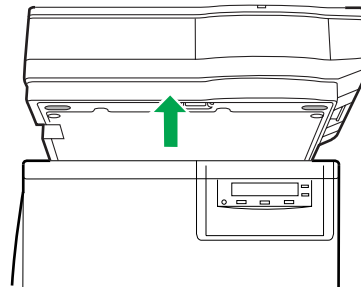

- 5** To lock the scanner, push and turn the lock clockwise with a flat-blade screwdriver.

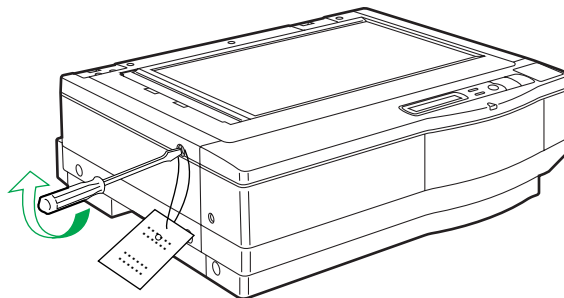

- 6 Repack the ADF and the scanner bed into the original carton.

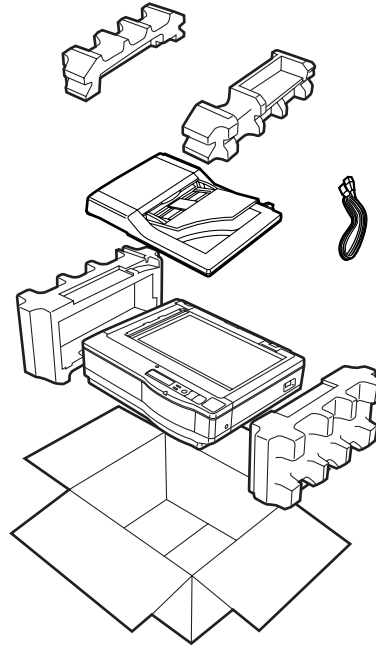

Packing the printer

To prepare the printer for repacking:

- 1 Turn off the printer; remove the power cord and all interface cables.
- 2 Remove the media tray(s) from the printer; remove the media from the tray(s).

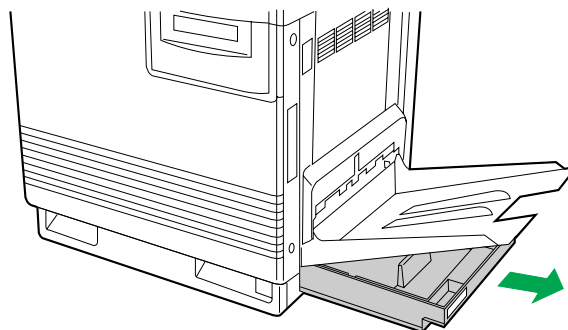

- 3** Press down on a media tray's metal plate. Place the cardboard packing material into the media tray.

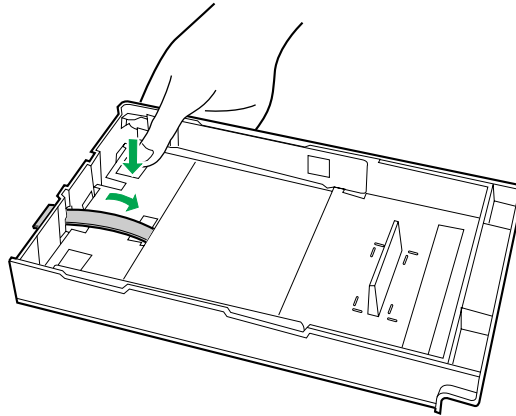

- 4** Reinsert the media tray into the printer; use adhesive tape to secure the tray to the printer.

- 5** If you have other media trays, repack them for shipping or storage in their original shipping boxes.

- 6**
- a) Open the printer's front door.
 - b) Loosen the two thumbscrews by turning them counterclockwise.
 - c) Turn the lower green lever 180° counterclockwise.

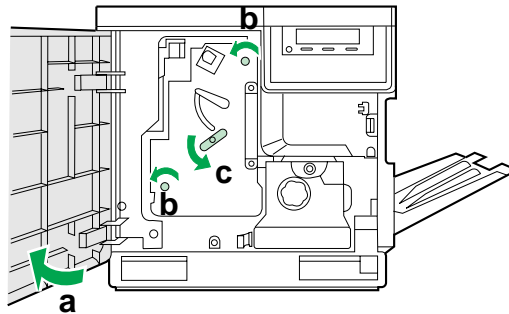

- 7**
- a) Grasping the front green handle, slide the unit out until it catches.
 - b) Lift up the green handle on the left and pull the color imaging unit out of the printer.

IMPORTANT:

- Do not touch the green surface (the right side) or the black belt (the under side). Finger prints may affect the print quality.

SAFETY CAUTION:



- The color imaging unit weighs approximately 6.5 kg {14.3 lbs.}. Always use the handles when lifting it.

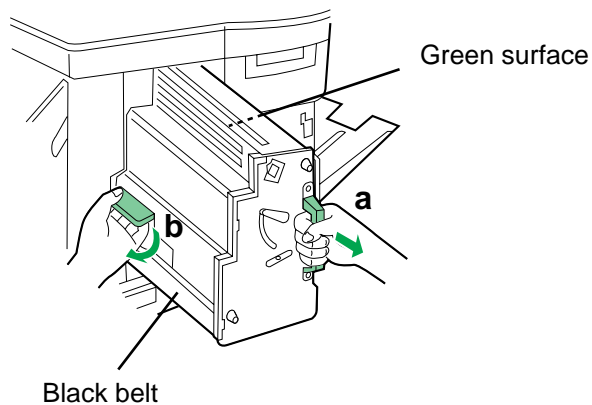

- 8**
- Wrap the color imaging unit with a protective black plastic sheet.

CAUTION:

- Do not expose the color imaging unit to light for more than 45 seconds to avoid damage.

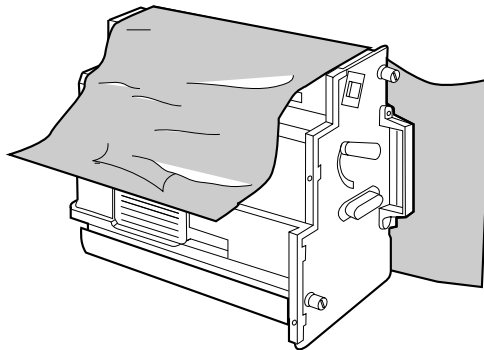

- 9** On the color imaging unit, turn the upper lever 90° counterclockwise; this is necessary to protect the color imaging unit during shipment.

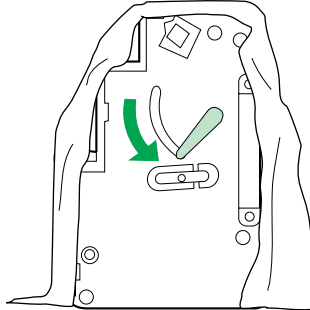

- 10** Insert the color imaging unit into the packaging.

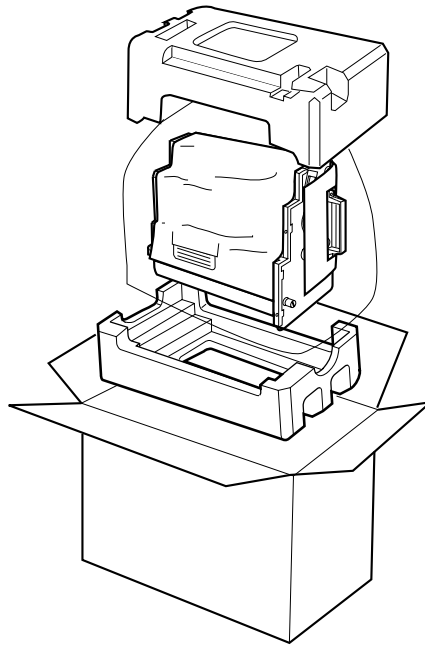

- 11** a) Open the left side door.
b) Slide the paper feeder out, using the green handles.

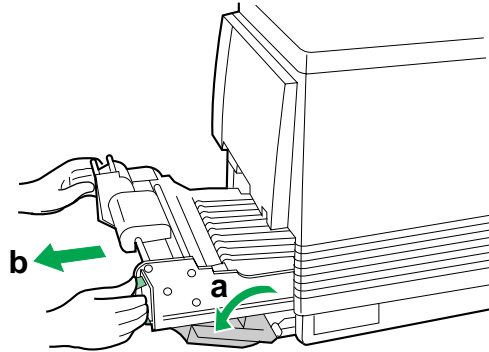

- 12** a) Push in on green tabs to unlock the cover.
b) Raise the cover until it catches in the open position.

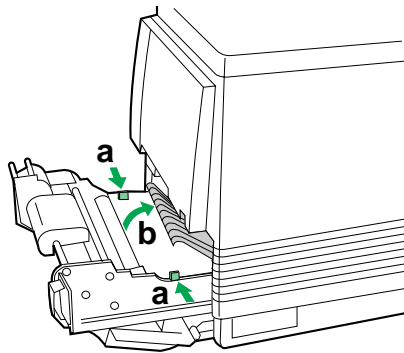

- 13** a) Rotate the transfer unit's green handles up.
b) Lift out the transfer unit.

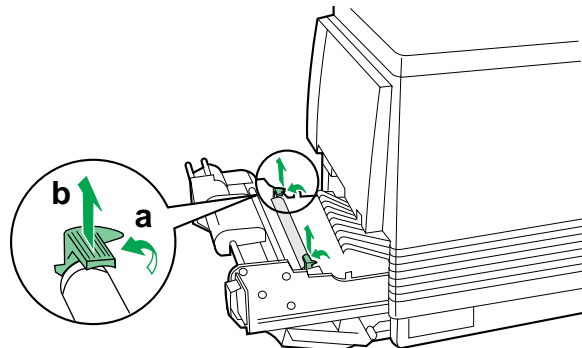

- 14** Place the transfer unit on newspaper or drop cloth. Rotate the handles down and wrap the transfer unit with a piece of paper and adhesive tape.

NOTE:

- Do not touch or bump the roller: it can damage the roller.

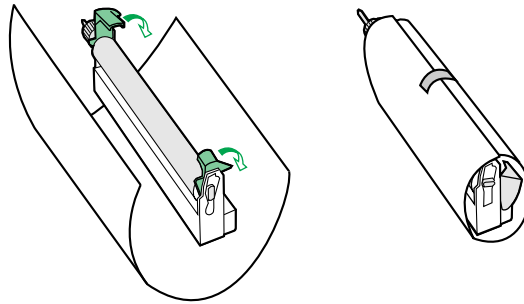

- 15** Install the plastic cover and insert the transfer unit into a plastic bag and seal the end tightly. Install the transfer unit into the packaging.

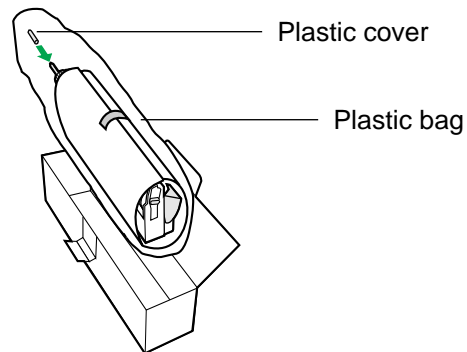

To pack the toner cartridges:

- 1** a) Open the right side door.
b) Remove each toner cartridge.

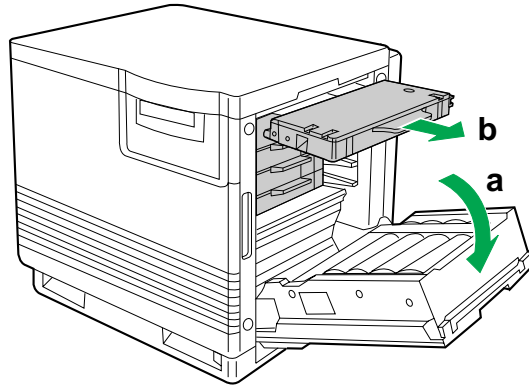

CAUTION:

- To avoid possible toner spillage, do not tilt the cartridge.

- 2** Close the right side door.

- 3** a) Replace the shipping cover.
b) Secure the shipping cover with adhesive tape.

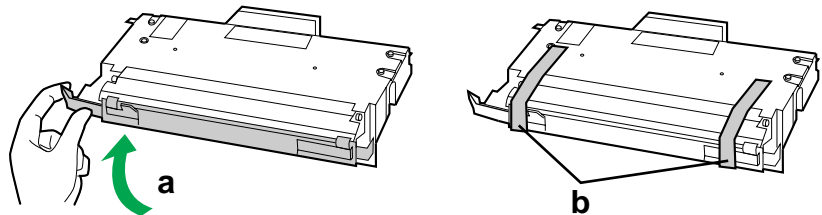

- 4** Insert each toner cartridge into a plastic bag and seal the end of the bag tightly.

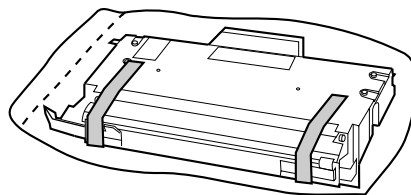

- 5** Repeat steps 2 through 4 for each toner cartridge.

To finish repacking the printer:

1 Wipe off any loose toner in and around the printer.

NOTE:

- If a toner vacuum is available, it is the best tool for cleaning spilled toner. Do not use a standard office vacuum; the toner will not be retained by typical vacuum dust collectors.

2 Raise the output tray and secure it to the printer with adhesive tape.

3 Secure the printer's front door, the multi-purpose tray and the left side door to the printer with adhesive tape.

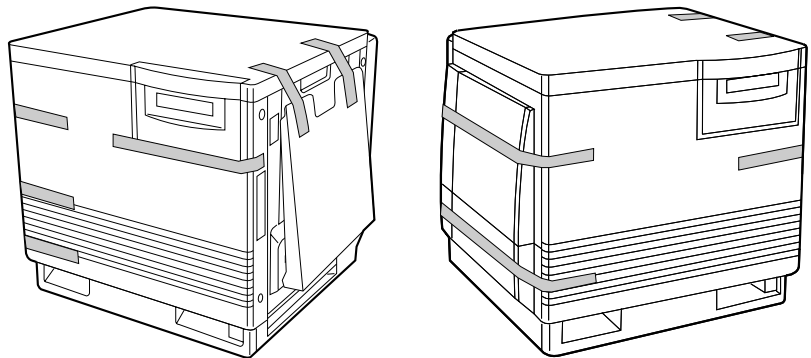

If you don't have a 2nd cassette feeder, go to step 6.

4 If you have a 2nd cassette feeder, lift the printer up and away from the 2nd cassette feeder.

SAFETY CAUTION:



- The printer weighs approximately 49.5 kg {108.9 lbs.} and the 2nd cassette feeder weighs approximately 14.3 kg {31.5 lbs.}. Observe standard precautions for lifting heavy objects.

5 Repack the 2nd cassette feeder in its original shipping box.

6 Repack any other accessories in their original shipping boxes.

- 7** Repack the printer in the original shipping box. Make sure that you keep the printer upright and level when moving.

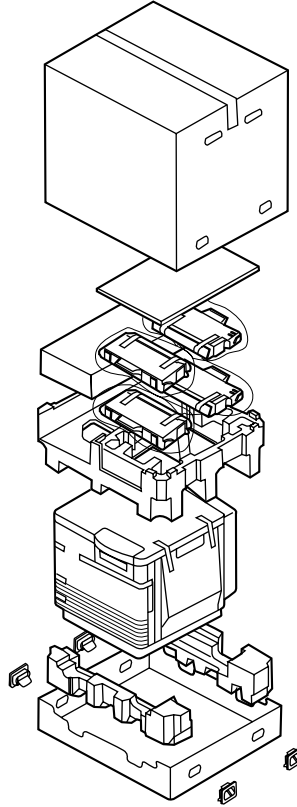

For the List of options, refer to the *Setup Manual*.

Upgrade options

The following upgrade options and consumables are available for the KX-PS8100 from your local Panasonic reseller:

- Hard Disk Drive (KX-PDHD1) for storing print jobs, and additional fonts (page 275)
- 32 MB (KX-PEMD2) or 64 MB (KX-PEMD3) SDRAM DIMMs (page 278)

Three DIMM slots are available on the printer controller board. Each slot can support a 16 MB, 32 MB or 64 MB SDRAM DIMM.

NOTE:

- A minimum of 48 MB of SDRAM is required for duplicating.
- Ethernet (KX-PNBC5) or Token Ring (KX-PNBC6) card (page 281)

You must remove the printer controller board from the back of the KX-PS8100 printer in order to install or replace the hard disk, add or replace memory, or install a Token Ring or Ethernet card.

IMPORTANT:

- To prevent static electricity damage to any of the following components, touch a grounded metal surface, such as the printer's bare metal frame prior to touching the component.
 - The interface connectors; SCSI, parallel, and optional network
 - ADF interface connector
 - Electrical components, connectors inside the printer, any components on the optional board (hard disk drive, SDRAM DIMMs, Ethernet network card, or Token Ring network card)
 - The connector pins on the optional 2nd cassette feeder for the printer

Removing and replacing the printer controller board

To remove the printer controller board:

- 1** Turn the printer OFF, unplug the power cord and disconnect any cables connected to the connectors on the back of the printer.
- 2** Loosen the two screws that secure the printer controller board to the back of the printer, using a cross-point head (+) screwdriver.

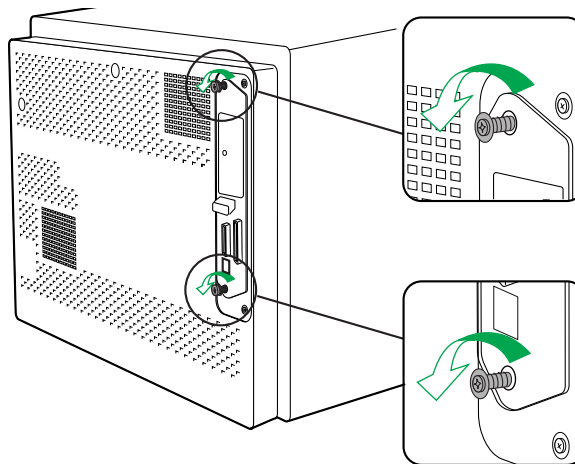

- 3** Carefully pull the printer controller board out of its slot in the printer.

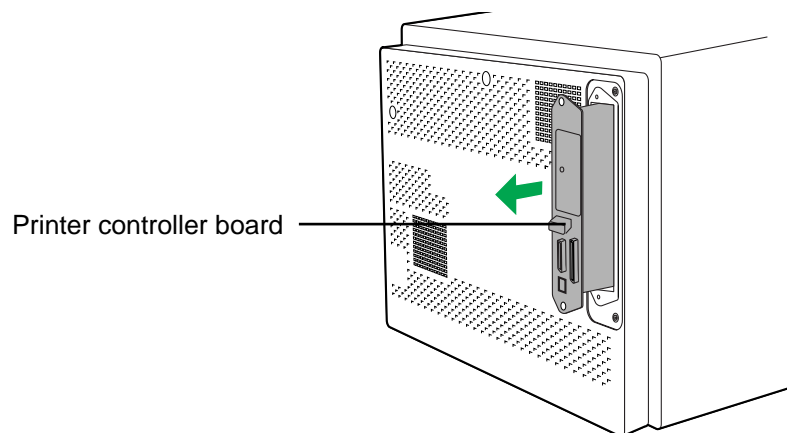

For instructions on installing printer options see:

- [“Installing a hard disk drive” on page 275](#)
- [“Installing additional memory” on page 278](#)
- [“Installing network cards” on page 281](#)

To replace the printer controller board:

- 1** Align the printer controller board with the groove on the back of the printer and carefully slide it back inside the printer.

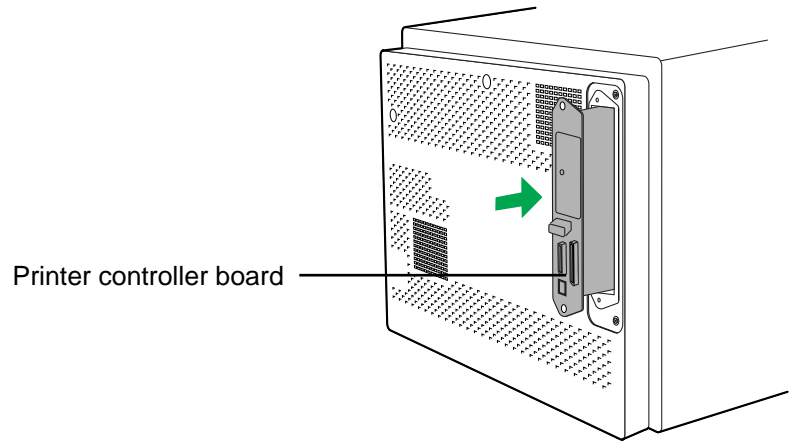

- 2** Tighten the two screws on the printer controller board that you loosened earlier, using a cross-point head (+) screwdriver.

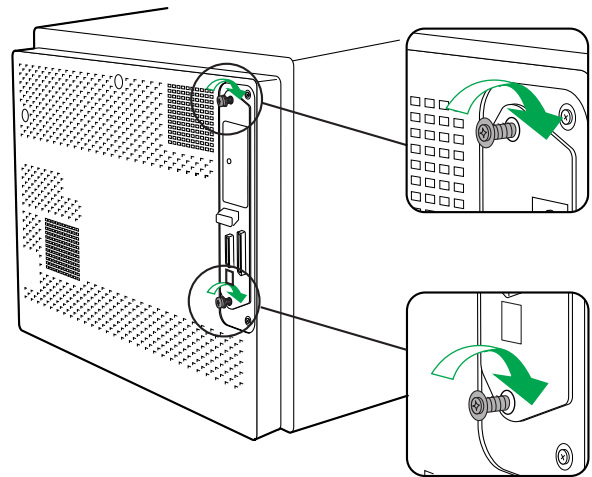

- 3** Plug in the power cord and reconnect any cables to the back of the printer.

Installing a hard disk drive

The following section explains how to install the hard disk drive on the printer. It also describes how to initialize the new hard disk drive for use from the printer panel.

To install the hard disk drive you will need to remove the printer controller board, install the drive and then replace the printer controller board in the printer. For instructions, see [“Removing and replacing the printer controller board” on page 273](#).

Kit contents

- Hard disk drive (KX-PDHD1)

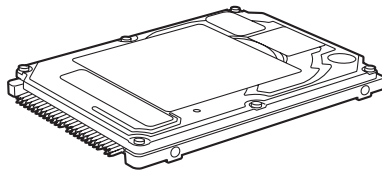

- Cable

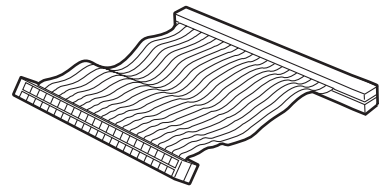

(The shape of a cable is subject to change.)

- Four screws



- Four stand offs



- Label

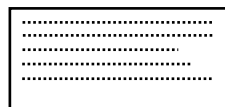

IMPORTANT:

- To prevent static electricity damage to certain components (see [page 272](#)), touch a grounded metal surface, such as the printer's bare metal frame prior to touching the component.

CAUTIONS:

- Do not drop or bend the hard disk drive.
- Do not touch the hard disk drive connector and electrical circuit board.
- Protect the hard disk drive from static electricity by keeping it in its anti-static package until you are ready to install it.
- Avoid exposing the hard disk drive to direct sunlight, high temperatures, or humidity.

To install a new hard disk drive:

- 1** Place the printer controller board on a stable surface.
- 2** Unpack the new hard disk drive. With the electrical circuit board side up, place the drive on a flat surface or on the palm of your hand.
Do not touch the drive with magnetic objects or place objects sensitive to magnets near the drive.
- 3** Screw the four stand offs in the back of the hard disk drive.

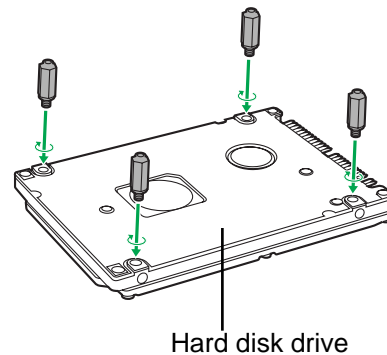

- 4** Insert the provided cable into the connector on the hard disk drive in the direction shown in the figure.
Please note the direction of the color line of the cable.

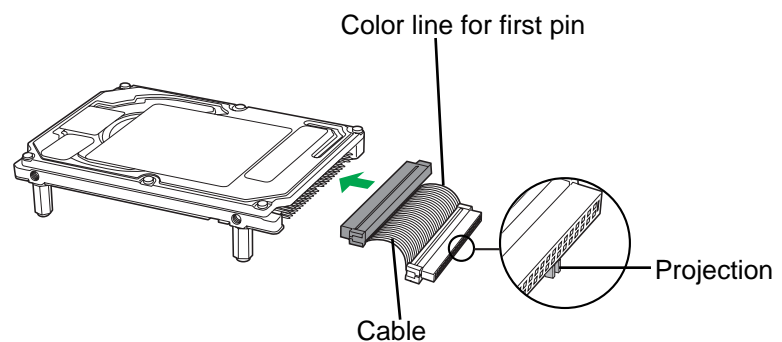

- 5** Insert the other end of the cable into the connector on the printer controller board, directing a projection on the cable against the groove in the connector. Slide the cable until the click is heard.

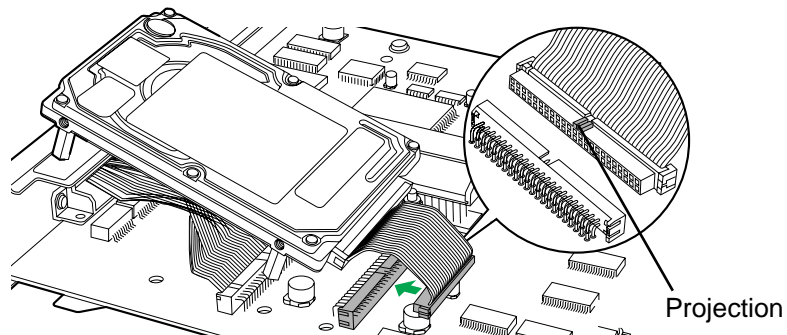

- 6** Put the four stand offs of the hard disk drive into the four holes, and secure the hard disk drive on the printer controller board with four screws.

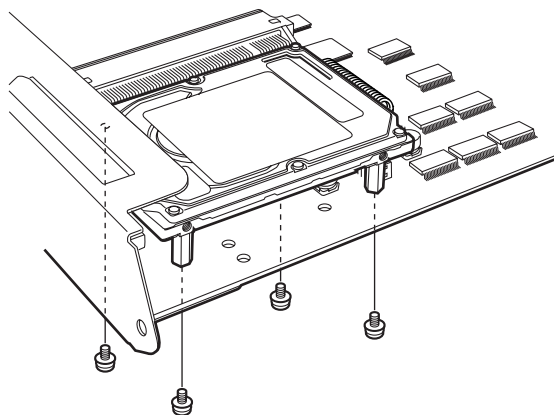

- 7** Stick the label provided to the hard disk drive.
- 8** Replace the printer controller board in the printer.
For instructions, see [“Removing and replacing the printer controller board”](#) on page 273.

Options

Initializing the hard disk

After you install the hard disk and power on the printer, you may be prompted to initialize the new hard disk drive. If so, follow the directions below:

- 1** From **Ready** or **Ready(Sleep)**, press the **MENU/EXIT** button to enter the **Setup** menus.
- 2** Press the **▲/CONTINUE** button until **"Hard Disk"** appears. Follow the instructions on the printer LCD panel.

Installing additional memory

The following section explains how to install a 32 or 64 MB SDRAM (Synchronous Dynamic Random Access Memory) DIMM (Dual In-line Memory Module) on the KX-PS8100.

To install the SDRAM DIMM (illustrated below) you will need to do the following:

- Remove the printer controller board from the back of the printer.
- Install a 32 or 64 MB SDRAM DIMM in either of the empty SDRAM slot on the printer controller board.
- Replace the printer controller board.

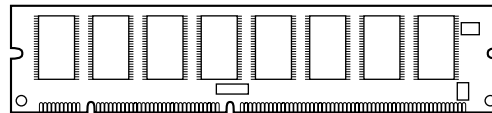

(The shape of a SDRAM DIMM is subject to change.)

IMPORTANT:

- To prevent static electricity damage to certain components (see [page 272](#)), touch a grounded metal surface, such as the printer's bare metal frame prior to touching the component.

Kit contents

- SDRAM DIMM

CAUTIONS:

- Do not drop or bend the SDRAM DIMM.
- Do not touch the connector edge of the SDRAM DIMM.
- Protect the SDRAM DIMM from static electricity by keeping it in its anti-static package until you are ready to install it.
- Avoid exposing the SDRAM DIMM to direct sunlight, high temperatures, or humidity.

Installing SDRAM DIMMs

The printer controller board ships with the following memory configuration:

- The DIMM slot numbered J1, is reserved for the printer's system software ROM DIMM.
- The DIMM slots numbered J8, J2 and J3 are reserved for SDRAM DIMMs. Install a SDRAM DIMM in the empty slot to increase the memory of your printer.

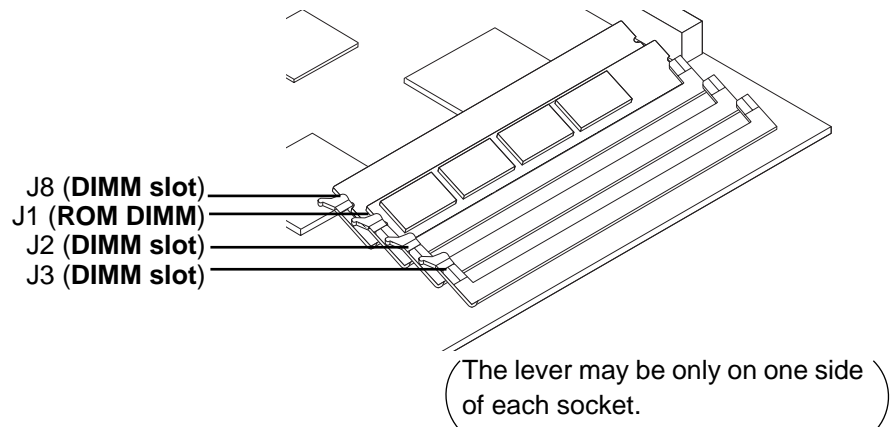

Additional SDRAM DIMMs may be used for your printer in 32 or 64 MB configurations, allowing your printer a maximum memory configuration of 192 MB of SDRAM.

To install a SDRAM DIMM you will need to remove the printer controller board, install the SDRAM DIMM, then replace the controller board in the printer. For instructions, see ["Removing and replacing the printer controller board" on page 273](#).

To install a SDRAM DIMM:

- 1** Unpack the SDRAM DIMM(s).
Do not touch the connector edge on the SDRAM DIMM.
- 2** Place the printer controller board on a stable surface.
- 3** Unlatch the lever on the side of the empty socket (J2 or J3).

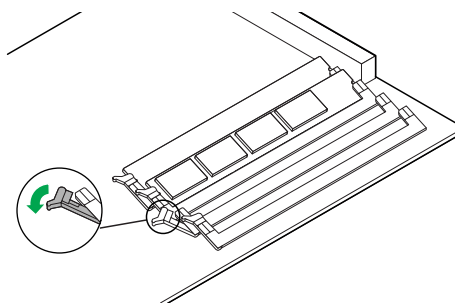

- 4** Ensure that the notches on the SDRAM DIMM are aligned inside the empty socket.

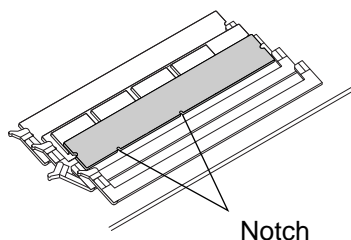

- 5**
 - a)** Slide the SDRAM DIMM into the empty socket (J2 or J3) at a 45-degree angle and push the DIMM into the socket.
 - b)** Snap the lever(s) into place.

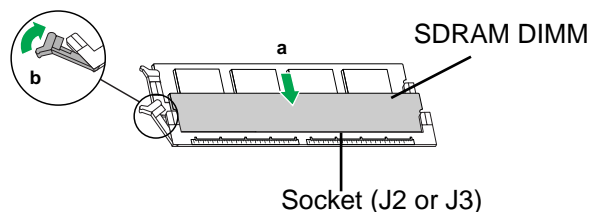

- 6** Replace the printer controller board in the printer.
For instructions, see ["Removing and replacing the printer controller board"](#) on page 273.

Installing network cards

The following section explains how to install either an Ethernet (KX-PNBC5) or Token Ring (KX-PNBC6) card (illustrated below) on the KX-PS8100. It also describes how to configure the printer Setup when the new network card has been installed.

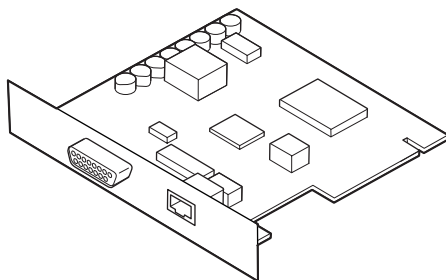

Ethernet card

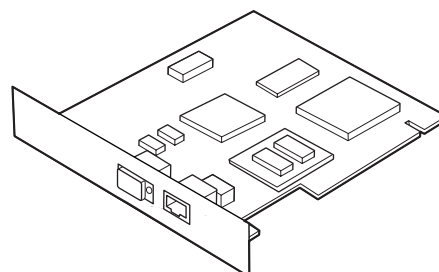

Token Ring card

To install the network card you will need to do the following:

- Remove the printer controller board from the back of the printer.
- Install the network card on the printer controller board.
- Replace the printer controller board.
- Configure the printer's network setup.

IMPORTANT:

- To prevent static electricity damage to certain components (see [page 272](#)), touch a grounded metal surface, such as the printer's bare metal frame prior to touching the component.

Kit contents

- Ethernet (KX-PNBC5) or Token Ring (KX-PNBC6) card

CAUTIONS:

- Do not drop or bend the network card.
- Do not touch the connector of the network card.
- Protect the network card from static electricity by keeping it in its anti-static package until you are ready to install it.
- Avoid exposing the network card to direct sunlight, high temperatures, or humidity.

Before you begin this procedure, remove the printer controller board from the printer. For instructions, see ["Removing and replacing the printer controller board"](#) on [page 273](#).

Installing a network card:

- 1** Place the printer controller board on a stable surface.
- 2**
 - a)** Use a flat blade screwdriver to gently remove the connector cover on the side of the network card connector.
 - b)** Remove the two screws that secure the slot cover on the front bracket, then remove the slot cover. Save the screws.

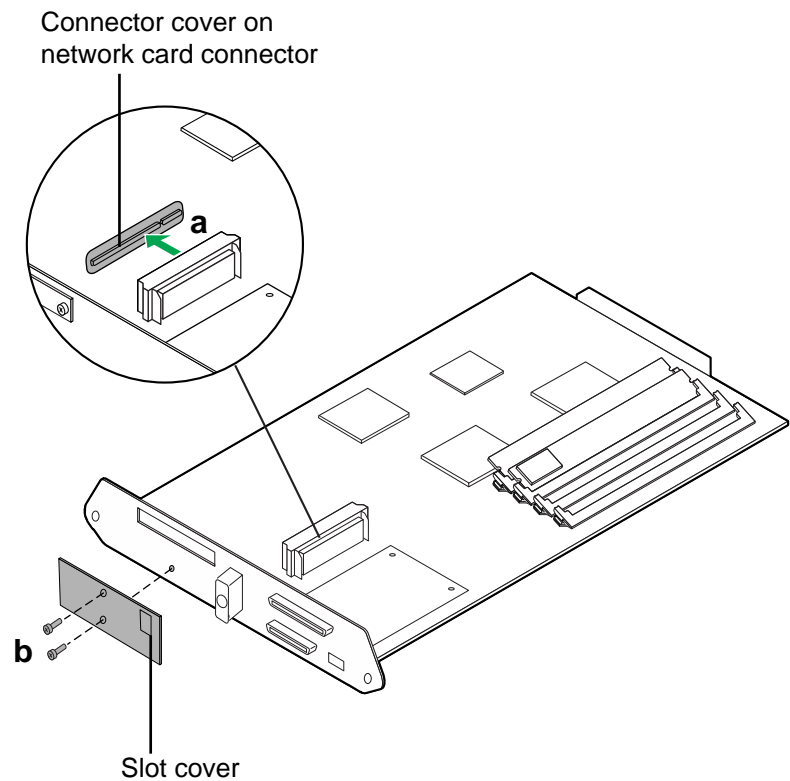

- 3**
 - a) Align the network card into the cutout in the front bracket.
 - b) Insert the network card into the network card connector.
 - c) Secure the network card to the front bracket using the two screws you removed from the slot cover.

Network card
[The figure is Ethernet
(KX-PNBC5) card.]

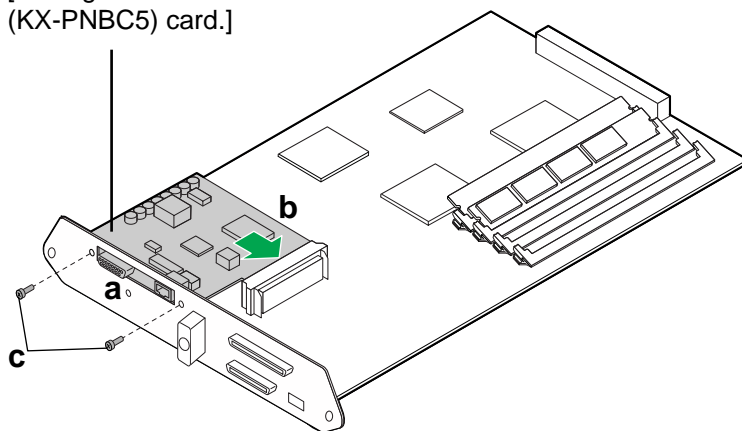

- 4** Replace the printer controller board in the printer.
For instructions, see [“Removing and replacing the printer controller board”](#) on page 273.
- 5** Connect the printer to a network.
For instructions, see [Chapter 3 “Connecting the Printer to a Network”](#).

Appendix

This appendix contains specifications for the following:

- Scanner
- Printer
- Duplicate
- Software
- Media
- Bidirectional Parallel Interface
- SCSI interface
- Controller

Specifications

Scanner

Power source

Refer to the nameplate on the rear of the unit.

Temperature

Operating: 10°C to 32.5°C
Storage: 0°C to 40°C

Humidity

Operating: 20% to 80% RH
Storage: 10% to 90% RH

Warm up time

Less than 20 seconds

Power consumption

70 W Max. (Scanning)
33 W (Standby)
30 W (Power Saver mode)

Mass {Weight}

22.5 kg {49.5 lbs.} (with ADF)

Dimensions

Height: 241 mm (9.5")
Depth: 425 mm (16.7")
Width: 513 mm (20.2")

Noise level

53 dB(A) [with ADF]

Scanner type

Flatbed Color CCD Scanner

Scanning system

Mirror moving optical system with R. G. B. 3 line Color CCD

Document type

Sheet, Book

Maximum scanning size

Horizontal: 216 mm (8.5")

Vertical: 356 mm (14")

Resolution

Flatbed Horizontal Line: Optical 600 dpi
30-2400 dpi (1 dpi step) by hardware interpolation
2401-9600 dpi (1 dpi step) by software interpolation
Vertical Line:
30-2400 dpi (1 dpi step) by changing carriage speed
2401-9600 dpi (1 dpi step) by software interpolation

ADF Horizontal Line: Optical 600 dpi
60-600 dpi (1 dpi step) by hardware interpolation
601-2400 dpi (1 dpi step) by software interpolation
Vertical Line:
60-600 dpi (1 dpi step) by changing paper feed speed
601-2400 dpi (1 dpi step) by software interpolation

Color depth

Internal: 30 bits/1billion color (RGB)

Output: 24 bits/16.7million color

Image data processing

- Image sharpening and unsharpening (3 x 5 MTF correction)
- Brightness/Contrast adjustment
- Pseudo halftone (Dither/error diffusion)
- Mirror, Positive/Negative reverse
- γ correction: Linear/Adjustable
- Background reduction
- Color/B & W mode

Scanning time*

Color, B&W gray scale (A4 size)

1.6 seconds	30, 60 dpi (prescan)
3.9 seconds	150 dpi
5.2 seconds	200 dpi
7.8 seconds	300 dpi
15.7 seconds	600 dpi
31.4 seconds	1200 dpi
62.7 seconds	2400 dpi
more than 62.7 seconds	2401-9600 dpi

Auto Document Feeder (ADF)

26.0 seconds (2.3 ppm)	600 dpi
18.5 seconds (3.2 ppm)	300 dpi
13.3 seconds (4.5 ppm)	200 dpi

* Initial time is not included.

Actual time depends on I/F speed and host environment.

Interface

SCSI-2 Connector: 50 pin half size x 2

Paper handling (ADF)

Document width: 100 mm to 216 mm (3.94" to 8.5")

Document length: 178 mm to 356 mm (7" to 14")

Document weight: 60 g/m² to 127.5 g/m² (16 lbs. to 34 lbs.)

ADF tray: up to 50 pages of document
[75 g/m² (20 lbs.) fresh paper]

Printer

Printing method

Semiconductor Laser

Power source

Refer to the nameplate on the rear of the unit.

Temperature

Operating: 10°C to 32.5°C (50°F to 90.5°F)

Best Print Quality: 15°C to 25°C (59°F to 77°F)

Storage: 0°C to 40°C (32°F to 104°F)

Humidity

Operating:	20% to 80% RH
Best Print Quality:	30% to 70% RH
Storage:	10% to 80% RH

Warm up time

Less than 300 seconds (at 20°C)

Power consumption

850 W Max. (printing with fuser on),
40 W (standby with fuser off),
35 W (Power Saver Mode) Meets Power Saver power conservation requirements.

Mass {Weight} of standard unit with consumables

(without optional 2nd cassette feeder)

49.5 kg {108.9 lbs.}

Dimensions of standard unit

(without optional 2nd cassette feeder)

Height: 463 mm (18.2")
Depth: 493 mm (19.4")
Width: 510 mm (20.1") [784 mm (30.9") with the output tray]

Noise level

53 dB(A) [Printing Mode]
47 dB(A) [Standby mode]

Paper output

Up to 500 sheets [75 g/m² (20 lbs.)]

Resolution

600 x 600 dpi
1200 x 600 dpi *
1200 x 1200 dpi *

* more than or equal to 48 MB SDRAM required

Maximum printing speed

3.5 ppm [4 Color (CMYK)]
4.7 ppm [3 Color (CMY)]
14 ppm (Monochrome) at 600 x 600 dpi

Interface

SCSI-2 Connector: 50 pin half size x 1

Duplicate

Document size

Original document size

Flatbed: Max. Legal (216 mm x 356 mm)

ADF: 100 mm x 178 mm-Legal

Duplicate paper size: A4, Letter, Legal

Original image type

Color: Text and Graphics Mode, Photo Mode

Mono: Text Mode, Halftone/Photo Mode

Maximum duplicate speed

[Standard, Letter or A4 size paper]

Continuous: 3.5 ppm [4 Color (CMYK)]

(Same original) 4.7 ppm [3 Color (CMY)]

14 ppm (Monochrome)

ADF duplicate: 3.5* ppm [4 Color (CMYK)]

(Different original) 4.7* ppm [3 Color (CMY)]

14* ppm (Monochrome)

* Continuous duplicate speed changes depending on the printed pattern of each page and the amount of the printer's SDRAM.

1st duplicate using Flatbed:

56 seconds [4 Color (CMYK)]

52 seconds [3 Color (CMY)]

42 seconds (Monochrome)

Multiple duplicate

Digital Duplicator Utility:1-999

Duplicate: 1-99

Zoom

Digital Duplicator Utility:20-400 (in 1% steps) XY independent

Duplicate: 100%

Image editing

Area duplicate

Color adjustment

Negative/positive

Mirror

Image repeat

Text drawing

Image saving

Interface

SCSI-2

Synchronous transfer up to 5 MB/s

Software

■ Windows version

TWAIN scanner driver
 Digital Duplicator Utility
 Print Count Manager

[Windows 3.1, Windows 95,
 Windows 98, Windows NT 4.0
 (Intel only)]

Printer driver

[Windows 3.1, Windows 95,
 Windows NT 4.0 (Intel only)]

Color Management: ICM (for Windows 95 only)

• System requirement

CPU: More than Pentium or Pentium PRO
 (133 MHz or faster CPU is recommended.)

Operating system: Windows 3.1, Windows 95, Windows NT 4.0
 (Intel only)

Memory: 16 MB or more (More than 32 MB is recommended.)

Freed disk space: 100 MB or more

Virtual memory: 16 MB or more (More than 32 MB is recommended.)
 for Windows 3.1/95
 50 MB or more (More than 100 MB is recommended.)
 for Windows NT 4.0

Display: Video card that can display more than 256 colors.
 (A video card that can display more than 32,000
 colors is recommended.)

Drive: CD-ROM drive

• Bundled software

CorelDRAW Select Edition (for Windows 95, Windows NT 4.0)

■ Macintosh version

TWAIN scanner driver
 Photoshop Plug-ins
 Printer driver
 Color Management: ColorSync

• System requirement

CPU: More than PowerPC
 (133 MHz or faster CPU is recommended.)

Operating system: System 7.5.x, 7.6.x or 8.0 (Printer Driver)
 System 7.5.x, 7.6.x, 8.0, 8.1 or 8.5 (Scanner Driver)

Interface: Ethernet card

• Bundled software

N/A

Media

Media sizes

Media	Size	Dimensions
Paper	Letter	216 mm x 279 mm (8.5" x 11")
	A4	210 mm x 297 mm (8.3" x 11.7")
	Legal	216 mm x 356 mm (8.5" x 14")
Transparency	Letter	216 mm x 279 mm (8.5" x 11")
	A4	210 mm x 297 mm (8.3" x 11.7")
Envelope	#10	104.3 mm x 241.3 mm (4.13" x 9.5")

NOTE:

- Please store your paper according to the recommendations of the manufacturer.

Margins and print area

When the image is printed on the media, the image (print area) is a bit smaller than the media size. You may need to adjust the page margins in the application software to match the print area.

The following table shows the page sizes, the largest print areas, and the margins for the media sizes supported on this printer.

Media	Page Size	Print area	Margins		
			Top	Bottom	Sides
Letter	216 mm x 279 mm (8.5" x 11")	208 mm x 270 mm (8.2" x 10.6")	4.2 mm (0.17")	4.3 mm (0.17")	3.9 mm (0.15")
A4	210 mm x 297 mm (8.3" x 11.7")	201 mm x 289 mm (7.9" x 11.4")	3.4 mm (0.13")	3.9 mm (0.15")	4.3 mm (0.17")
Legal	216 mm x 356 mm (8.5" x 14")	208 mm x 346 mm (8.2" x 13.6")	3.2 mm (0.13")	6.0 mm (0.24")	3.9 mm (0.15")

■ Paper weight

The printer is designed to work well with most types of paper. However, differences in paper may have significant effects on the quality of the print or the reliability of paper handling. It is strongly recommended that you always test paper before purchasing it to make sure it provides desirable performance.

Media tray	One-sided printing	B&W	60 to 105 g/m ² (16 to 28 lbs.)
		Color	75 to 105 g/m ² (20 to 28 lbs.)
Multi-purpose tray	One-sided printing	B&W	75 to 165 g/m ² (20 to 44 lbs.)
		Color	75 to 165 g/m ² (20 to 44 lbs.)
	Two-sided printing	B&W	95 to 165 g/m ² (28 to 44 lbs.)
		Color	95 to 165 g/m ² (28 to 44 lbs.)

• Recommended paper (for optimum performance):

LETTER/LEGAL: Hammermill LASERPRINT 90 g/m² (24 lbs.)

A4: NEUSIEDLER COLOR COPY 90 g/m²

NOTE:

- We do not recommend the use of 105 g/m² (28 lbs.) paper in areas of high or low humidity and temperature since paper feed problems may be experienced.

■ Types of paper to avoid

- Extremely smooth or shiny paper or paper that is highly textured
- Letterhead imprinted with low temperature or thermography. These materials may transfer onto the fusing roller and cause damage. Any pre-printed paper should use inks compatible with 200°C (392°F) for 0.1 second.
- Damaged or wrinkled paper, or paper with irregularities such as tabs, staples, etc.
- Multipart forms or carbonless paper
- Paper with a 25% or more cotton and/or fiber content
- Ink jet paper (It may transfer onto the fuser roller and cause damage.)
- Ink jet transparency (It may be wrapped around the fuser roller and cause damage.)

Two-sided printing (Duplex printing)

Two-sided printing is possible by using the multi-purpose tray. However, you should not expect the same print quality and reliability that you get with one-sided printing. We strongly recommend that you follow the guidelines below.

- Do not load more than 50 sheets in the multi-purpose tray.
- Before loading paper in the multi-purpose tray, adjust it so that the edges of the media are lightly touching the media guides of the multi-purpose tray.
- Use heavier paper, at least 95 to 165 g/m² (28 to 44 lbs. Bond) for reliable feed. **Do not load a thin sheet of paper in the multi-purpose tray.** It may cause a paper jam.
- It is strongly suggested to use color laser bond paper.
- Duplex printing on certain types of paper may shorten the life of some components in the printer.
- Use multi-purpose tray for second side printing.
- When printing on the first page, avoid printing photograph or graphic in solid color to prevent paper jamming. It may cause a damage to the printer. For increased reliability print the page with the least amount of toner coverage first. (See below.)
- Before printing on the first side, set the unprintable area [at least 15 mm (0.59") in length] on the top of paper. (See below.)

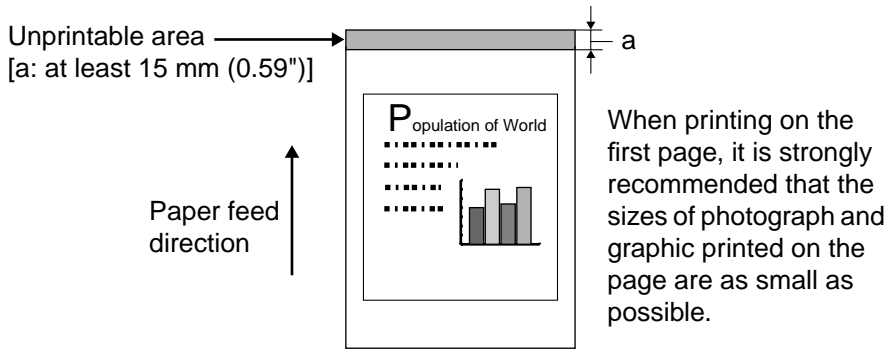

The first side printing

OK

Ex. Characters

N.G.

Ex. Photograph in solid color

■ **Transparencies and labels**

You may also print on transparencies and labels that are made for the printer. Panasonic has tested and found that the following work satisfactorily:

OHP transparency: 3M CG3710

- Re-using transparencies that have been fed through the printer once (for example, after jams or if the transparency is ejected without being printed) can reduce the life of the consumables and paper path components.
- The transparency has a side to be printed. The other side has a leading tape.

When loading the transparency, load it with the taped end entering the printer first.

The transparency can be loaded in the multi-purpose tray and transparency tray (option). To get better print result, use the transparency tray. Note that the direction for loading differs depending on each tray.

Labels: AVERY 5163, AVERY 5164, AVERY 5165, Avery L7163, Avery L7165, Avery L7166, Avery L7167, Avery L7168, Avery L7169

- With any label stock, the labels must completely cover the backing material.

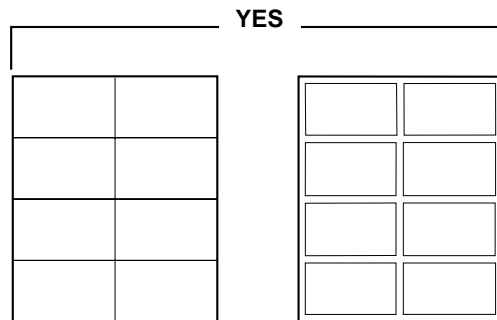

Labels cover the entire backing material.

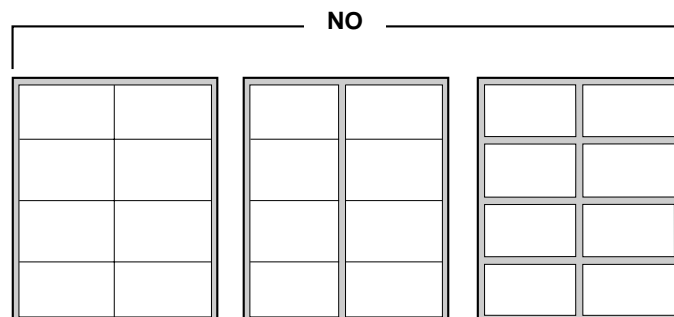

The backing material is exposed.

■ Envelopes

It is recommended that you print in black text only and purchase high quality #10 or larger laser envelopes with diagonal seams, as shown in the diagram below:

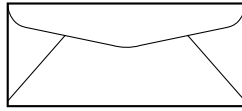

High quality envelopes have the following characteristics:

- A thin, sharply creased leading edge
- Paper weight of 90 g/m² (24 lbs.)
- Flat, free of curls, wrinkles, nicks, etc.

NOTES:

- Wrinkle may occur in some case, even if high quality envelopes are used.
- When wrinkle occurs, try printing with the envelope flap tucked in as shown below.

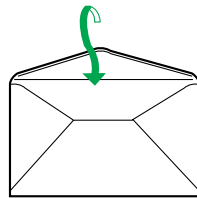

It is not recommended that you use envelopes with any of the following characteristics (using these may result in paper jams):

- Irregularly shaped envelopes
- Envelopes with curls, wrinkles, nicks, twists, dog-ears or other damage

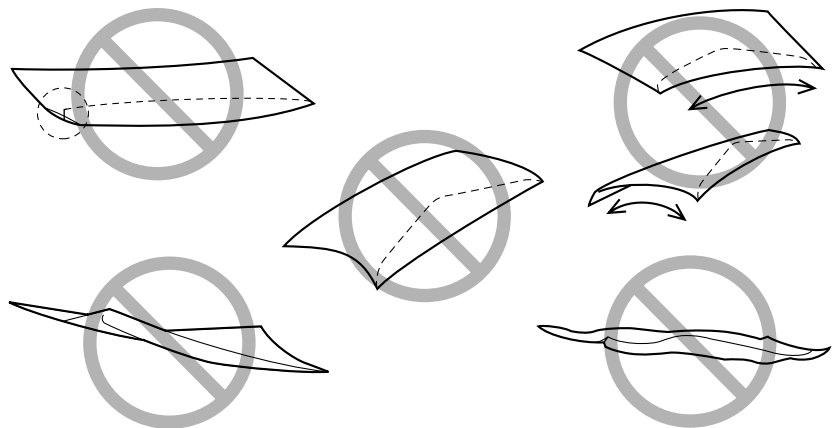

- Envelopes with side seam construction

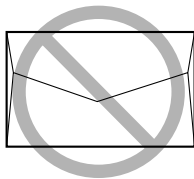

- Highly textured envelopes, or with extremely shiny surfaces
- Envelopes that seal by removing a peel-off strip

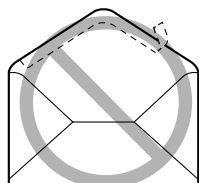

- Envelopes with more than one flap to be sealed

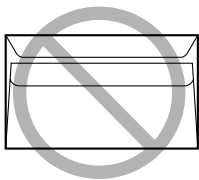

- Self-adhesive envelopes

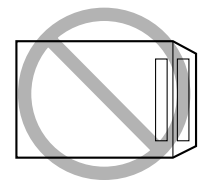

- Envelopes that are baggy or not sharply creased
- Embossed envelopes
- Envelopes that have previously been printed on

Do not attempt to print on any of the following types of envelopes. These may cause damage to your printer.

- Envelopes with clasps, snaps or tie strings (as illustrated on left below)
- Envelopes with transparent windows (as illustrated on right below)
- Envelopes that will melt, discolor, scorch offset or release hazardous emissions when exposed to 200°C (392°F) for 0.1 second
- Envelopes that use encapsulated types of adhesive that do not require moistening but rely on pressure to seal them

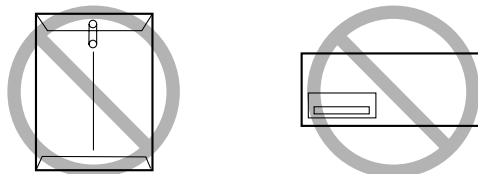

Always test a sample of the envelopes you are thinking of buying. Confirm that the envelope performs acceptably.

■ For best printing results

- Avoid printing in high humidity i.e., above 70% RH.
High humidity may cause the envelope to curl and pick up excess toner.
High humidity may also cause the envelope to seal.
- Avoid printing below 10°C (50°F) with less than 30% RH.
Low temperature with low humidity may cause light printing.
- Print only one envelope at a time.

Envelope storage is very important. Store them away from moisture and humid air, where they can lay flat and their edges won't be bent or damaged. The humidity should not exceed 70% RH.

Bidirectional parallel interface

The bidirectional parallel interface is based on the IEEE P1284-C standard.

If your computer has a bidirectional parallel port, the printer driver and printer can take advantage of faster data transfer.

■ Specifications

Connector Type	IEEE 1284-C type connector
Cable	Use a shielded cable 1.8 m (5.9 ft) or less in length.

■ Pin configuration

Signal pin	Return side pin	Signal
1	19	Busy
2	20	Select
3	21	nAck
4	22	nFault
5	23	PError
6	24	Data 1
7	25	Data 2
8	26	Data 3
9	27	Data 4
10	28	Data 5
11	29	Data 6
12	30	Data 7
13	31	Data 8
14	32	nInit
15	33	nStrobe
16	34	nSelectin
17	35	nAutoFd
18	—	+5V(Host)
36	—	+5V(Peripheral)

■ Parallel Interface connector (printer side)

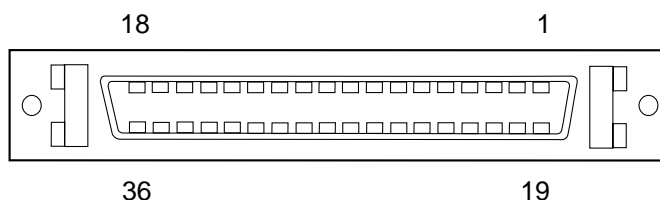

NOTES:

- “Return” denotes the return side wire of a twisted pair cable and is connected to signal ground.
- Be sure to use only a shielded cable. The printer will not operate properly if any of the pin is not connected.

SCSI interface

■ SCSI interface

The Panasonic DCIS SCSI interface is based on fast SCSI-2 ANSI standard.

■ Specification

Connector Type	50-Pin Half Pitch Pin-type Connector
Cable	Use a shielded cable for SCSI-2 (FAST SCSI). The total length of the SCSI chain must not exceed 3 m (9.8 ft.) to ensure reliable operation.

■ Pin configuration

Signal Pin	Signal	Signal Pin	Signal
1	GND	26	-DB(0)
2	GND	27	-DB(1)
3	GND	28	-DB(2)
4	GND	29	-DB(3)
5	GND	30	-DB(4)
6	GND	31	-DB(5)
7	GND	32	-DB(6)
8	GND	33	-DB(7)
9	GND	34	-DB(P)
10	GND	35	GND
11	GND	36	GND
12	(RESERVED)	37	(RESERVED)
13	(OPEN)	38	TERNPWR
14	(RESERVED)	39	(RESERVED)
15	GND	40	GND
16	GND	41	-ATN
17	GND	42	GND
18	GND	43	-BSY
19	GND	44	-ACK
20	GND	45	-RST
21	GND	46	-MSG
22	GND	47	-SEL
23	GND	48	-C/D
24	GND	49	-REQ
25	GND	50	-I/O

■ SCSI connector (printer and scanner side)

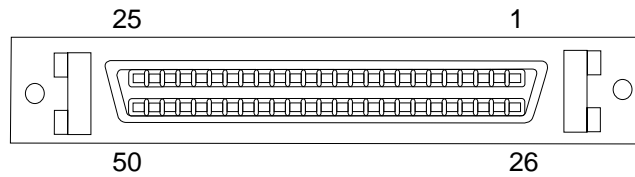

Controller

CPU

133 MHz, R4700 CPU

Hard disk drive

Option

ROM

16 MB

Memory (SDRAM)

Standard: 16 MB SDRAM DIMM

Optional: additional 32 MB or 64 MB SDRAM DIMM upgrades available.
 (Expandable to a maximum 192 MB of SDRAM)
 (The amount of the memory depends on the model.)

Host interface

IEEE compliant, 1284 type C, Mini-Centronics parallel port interface

Ethernet card (option): AUI and RJ-45 (10/100Base TX: auto switching)
 (Some of the KX-PS8100 models have an Ethernet card already installed.)

Token Ring card (option): RJ-45

User interface

24 character, 2 line LCD panel, 2 indicators

Index

Numerics

- 100BaseTX 70
- 10Base2 70
- 10Base2, 5, T Ethernet cable 70
- 10Base5 70

A

- AC inlet 33, 34, 62–65
- ADF
(Automatic Document Feeder) 47, 186, 187
 - top cover 33, 210, 218, 246
 - tray 33, 37, 186, 187
- Adobe Type Manager (ATM)
 - for Macintosh users 144
 - for Windows users 130
- AppleTalk
 - connecting to Macintosh 138
 - enabling 149
- AppleTalk Setup 149
- AppleTalk Zone 162
- AppleTalk Zone option 149
- AUI (attachment unit interface) 70

B

- Bias adjustment 171–175
- Bidirectional parallel interface 296
- Bindery
 - emulation mode 162
- Bindery context 84
- Bindery setup 165

C

- Cables, types supported 25, 70
- Calibration 170–185
 - bias adjustment 171–175
 - color adjustment 183–185
 - VisualCal 176–182
- Cancel 81
- Cautions
 - CD-ROM 21
 - using the printer 19–20
- Chooser 138
- Cleaning 209–212
 - printer 210
 - scanner 209

- CMYK color reference 132
- Color
 - adjustment 183–185
 - bias adjustment 171–175
 - calibration 170–185
 - VisualCal 176–182
- Color Calibration Card 32, 171, 173
- Color imaging unit 40, 214
- Color reference pages 132
- ColorSync printer profile 139, 140
- ColorWise™ 25
- Configuration Page 203
- Connecting Macintosh by AppleTalk 90
- Connecting the printer
 - using thicknet cable 71
 - using thinnet cable 71
 - using twisted pair cable 72
- Connecting the system 57–65
 - DCIS stand alone system 65
 - DCIS standard system 60
 - the printer to a local port of a PC 64
 - the scanner to a computer 62
- Connector 70–72, 296, 298
- Controller 299
 - CPU (Central Processing Unit) 299
 - host interface 299
 - user interface 299
- CorelDRAW Select Edition 133, 189
- Coverage of toner 216

D

- DCIS (Digital Color Imaging System) 60, 65
- DNS (Domain Name Server) name 119
- Document guides 33, 187
- Documents 186
- Duplex printing 292
- Duplicating
 - using the digital duplicator utility 194
 - using the scanner panel 196

E

- EFIRGB monitor profile 140
- Enable AppleTalk option 149
- Energy Star mode 146
- Envelopes 294

- Error indicator
 on the printer. 198
 on the scanner 204
- Error messages
 “No AppleTalk zone found” 162
 displayed on printer front panel. 198
 displayed on scanner front panel 204
- Ethernet cable, types supported 70
- Ethernet card 147
 installing 281
- ## F
- Features 23
 digital duplicator 26
 printer 24
 scanner 23
- Fiery WebDownloader 80, 152
- Fiery WebSetup 151–169
 exiting 169
 Network Setup 158–167
 Printer Setup. 168–169
 saving 169
 System Setup 156–157
- Fiery WebTools 26, 151
- Fonts 130, 144
- Fuser unit 215
- ## G
- Gateway Address. 74, 149
- Guide pins 32, 46
- ## H
- Hard disk drive
 initializing 150, 278
 installing 275–277
- Hosts file 76
- ## I
- IEEE P1284-C 296
- Initial setup from the printer panel 145
- Installing
 additional memory 278–280
 additional software, Macintosh 144
 additional software, Windows 130
 fonts 130, 144
 hard disk drive. 275–277
 network cards 281–283
 PostScript printer driver for Macintosh 137
 PostScript printer driver for Windows 3.1 123
 PostScript printer driver for Windows 95 95
 PostScript printer driver
 for Windows NT 4.0 115
 PostScript printer driver
 to Windows 98 103, 110
 scanner driver for Macintosh. 141
 scanner driver for Windows 3.1. 128
 scanner driver for Windows 95 99
 scanner driver for Windows NT 4.0. 120
 scanner driver to Windows 98. 103
 SDRAM DIMM 279
- ## Interface
- bidirectional parallel interface 296
 cables 296, 298
 Macintosh 29
 SCSI 298
 Windows 29
- Internet browsers 80, 151
- Internet Explorer 80
- Internet Explorer 4.x. 152
- IP Address 73, 148
- IPX (Novell) printing 82–90
 with Macintosh 90
 with Windows 3.1 126
 with Windows 95. 98
- IPX/SPX Setup. 150
- ## J
- Jams, clearing 218–233
 printer 220
 scanner 218
- Java Applet enabling 152
- ## L
- Labels. 293
- Language setup 150
- LCD panel messages
 printer 248
 scanner 246
- Life of supplies 216

Index

Lpr (TCP/IP) 73
 displaying the queue 81
 platforms supporting printer 73
 print queues 75
 printing 81
 setting up system 75–79
 setup summary 73–75
LPR printing 118
Lprm 81
Lpstat 81

M

Macintosh computers
 installing PostScript printer driver 137
 installing the scanner driver 141
 installing TrueType fonts 144
 on IPX (Novell) network 90
 on TCP/IP network 80
Margins and print area 290
MAU (Media Attachment Unit) 72
Media 48, 290–296
Media sizes 290
Media thickness switch 52
Memory
 installing additional 278–280
Messages
 error, printer 198
 error, scanner 204
 printer LCD panel 248
 scanner LCD panel 246
 status, printer 197
 status, scanner 204
Microsoft Internet Explorer, *see* Internet Explorer
MPT (Multi-Purpose Tray) 52

N

NDS (NetWare Directory Services)
 configuration 163
NDS tree
 browsing 163
 selecting 164
Netscape 3.x 152
Netscape 4.x 152
NetWare
 bindery and NDS on the same network 163
 client setup 90
 Print Console 87

 print queue 82, 87
 queue 88
 server 83
 services 163
NetWare 4.x bindery context 84
Network cards 281–283
Network connections
 Ethernet 70
 Token Ring 72
Network Port setup 146
Network Protocol setup 148
Network settings
 using Fiery WebSetup 151–169
 using printer panel 145–150
Networking 25
NIS server 75
Novell NetWare
 (shell version 3.26 and above) option 126

O

Oil supply roll 215
Options 272
Output tray 41

P

Pages
 color reference 132
 See Test Print
PANTONE coated color reference 132
Paper to avoid 291
Paper weight 291
Paper-pick rollers 211
Parallel cable, connecting to printer 296
Parallel interface 296
Parallel Interface connector 297
Parallel port 296
Parallel Port setup 146
Parallel printing
 on Windows NT 4.0 117
 with Windows 95 97
Part names
 printer 34
 scanner 33
Password tab 157
Peer to peer printing, *see* Windows (SMB) printing
Photoshop Plug-in scanner driver 143, 191

- Pin configuration
 - bidirectional parallel interface 297
 - SCSI interface 298
 - Ping 79
 - Plug and Play 102
 - Port Setup tab 158
 - PostScript and TrueType fonts
 - for Macintosh users 144
 - for Windows users 130
 - PostScript files, printing 159
 - PostScript Font List 203
 - PostScript printer driver
 - for Macintosh 137
 - for Windows 3.1 123
 - for Windows 95 95
 - for Windows NT 4.0 115
 - to Windows 98 103, 110
 - Power on 68
 - Power Saver 146
 - Power source 15, 30
 - Power switch 33, 34
 - Print Count Manager program
 - for Windows 3.1 129
 - for Windows 95 101
 - for Windows NT 4.0 122
 - Print queue on a UNIX system 81
 - Print queues 75
 - Printcap file 77
 - Printer
 - bias adjustment 171–175
 - calibrating 177
 - color adjustment 183–185
 - color calibration 170–185
 - color capabilities 25
 - enabling AppleTalk option 149
 - enabling IPX/SPX 150
 - enabling TCP/IP 148
 - font list 130
 - home page 153
 - Printer controller board
 - removing 273
 - replacing 274
 - Printer drivers
 - installing 95, 103, 115, 123, 137
 - Printer panel
 - menus 198–201
 - messages 248
 - overview 38
 - specifying network settings 145
 - Printer's error messages 198
 - Printer's main menus 198
 - Printer's status messages 197
 - Printing
 - scanned document 192
 - test pages 69, 202
 - Problems
 - printing 198
 - scanning 204
 - Protocol Setup tab 160
 - Protocols
 - lpr (TCP/IP) 75
 - supported 25
 - PS Setup tab 168
 - PSCRIPT.DLL file 115
 - PServer Setup tab 162
- ## R
- Remote Printer Setup 151–169
 - Removing software 134
 - Repacking 260–271
 - printer 263
 - scanner 261
 - Replaceable components 213
 - Reset queues 150
 - RGB source profiles 25
 - RJ-45 jack 72
 - Running Setup remotely 151–169
- ## S
- Scanned document
 - printing 192
 - saving 193
 - Scanner driver and utilities
 - for Macintosh 141
 - for Windows 3.1 128
 - for Windows 95 99
 - for Windows NT 4.0 120
 - to Windows 98 103
 - Scanner glass 33, 186, 188
 - Scanner lock 33, 44
 - Scanner panel
 - menus 204–208
 - messages 246
 - overview 35
 - specifying scanner settings 204
 - Scanner's error messages 204

Index

Scanner's main menus 204
Scanner's status messages 204
Scanning 188
Screen fonts
 Macintosh 144
 Windows 130
SCSI cable 32, 61
SCSI connector 33, 34, 60–62, 65, 299
SCSI ID number 66
SCSI interface 298
SDRAM DIMM 278–280, 299
Service calls 254
Service setup tab 166
Setting up the printer 40–44
Setting up the scanner 44–48
SMB printing 91–93, 166
 on Windows 95 91
 on Windows NT 4.0 93
Software
 Macintosh version 289
 Windows version 289
Software installation
 Macintosh 137–143
 Windows 3.1 123–129
 Windows 95 95–101
 Windows 98 103–113
 Windows NT 4.0 115–122
Space requirements 30
Specifications
 duplicate 288
 printer 286
 scanner 284
Specifying
 AppleTalk zone 149
Spool directory, UNIX server 77
Status Display program 255
Status Display window
 printer 258
 scanner 256
Subnet mask 73, 149
System requirements
 Macintosh 29
 Windows 28
System setup tab 156

T

TCP/IP clients 80

TCP/IP printing 73–81
TCP/IP Setup 148
10Base2, 5, T Ethernet cable 70
Terminator 66
Terminology, Novell 165
Test Print 69, 202
Thicknet cable 25, 71
Thinnet cable 25, 71
Token Ring card 147
 installing 281
Toner cartridges 42, 215
Transfer unit 216
Transparencies 293
Troubleshooting 234–246
 printer 236–246
 scanner 234–235
TWAIN compliant application 188
TWAIN scanner driver 142, 191
Twisted pair cable 25, 72
Two-sided printing 292

U

UNIX printing 77
UNIX systems 75
Unpacking
 printer box 32
 scanner box 31
Upgrade options 272
URL 154
User Login object 164

V

VisualCal 176–182

W

WebSetup 151–169
Windows 3.1
 installing PostScript printer driver 123
 installing the scanner driver 128
 installing TrueType fonts 131
 IPX (Novell) printing 126
Windows 95
 installing PostScript printer driver 95
 installing the scanner driver 99
 installing TrueType fonts 131
 IPX (Novell) printing 98
 parallel printing 97

Windows 98
 installing PostScript printer driver 103, 110
 installing the scanner driver 103

Windows NT 4.0
 device name 120
 installing PostScript printer driver 115
 installing the scanner driver 120
 installing TrueType fonts 131
 parallel printing 117
 running WebDownloader
 with Netscape Communicator 80
 TCP/IP printing 118

Z

Zones, AppleTalk 149