



Instruction Manual



EDR810H/EDR810M
EDR410H/EDR410M

EVERFOCUS ELECTRONICS CORPORATION

EDR 810H/810M/410H/410M

Instruction Guide

© 2005 EverFocus Electronics Corp
www.everfocus.com

All rights reserved. No part of the contents of this manual may be reproduced or transmitted in any form or by any means without written permission of the Everfocus Electronics Corporation.

Release Date: April 2009

QuickTime is a registered trademark of the Apple Computer, Inc.

Windows is a registered trademark of the Microsoft Corporation.

Linksys is a registered trademark of the Linksys Corporation.

D-Link is a registered trademark of the D-Link Corporation.

DynDNS is a registered trademark of the DynDNS.org Corporation.

Other product and company names mentioned herein may be the trademarks of their respective owners.

Federal Communication Commission Interference Statement

This equipment has been tested and found to comply with the limits for a Class B digital device, pursuant to Part 15 of the FCC Rules. These limits are designed to provide reasonable protection against harmful interference in a residential installation. This equipment generates, uses and can radiate radio frequency energy and, if not installed and used in accordance with the instructions, may cause harmful interference to radio communications. However, there is no guarantee that interference will not occur in a particular installation. If this equipment does cause harmful interference to radio or television reception, which can be determined by turning the equipment off and on, the user is encouraged to try to correct the interference by one of the following measures :

- Reorient or relocate the receiving antenna.
- Increase the separation between the equipment and receiver.
- Connect the equipment into an outlet on a circuit different from that to which the receiver is connected.
- Consult the dealer or an experienced radio/TV technician for help. FCC Caution: Any changes or modifications not expressly approved by the party responsible for compliance could void the users' authority to operate this equipment. This device complies with Part 15 of the FCC Rules. Operation is subject to the following two conditions: (1) This device may not cause harmful interference, and (2) this device must accept any interference received, including interference that may cause undesired operation. This device and its antenna(s) must not be co-located or operating in conjunction with any other antenna or transmitter.

CE Declaration

This equipment has been tested and found to comply with the limits for a **CE Class B** digital device,

The changes or modifications not expressly approved by the party responsible for compliance could void the user's authority to operate the equipment.

In a domestic environment this product may cause radio interference. In which case the user may be required to take adequate measures.



TABLE OF CONTENTS

1. PRODUCT OVERVIEW	12
1.1 FEATURES	12
1.2 SPECIFICATIONS	13
1.3 FRONT PANEL KEYPADS	14
1.4 BACK PANEL CONNECTIONS	17
1.5 MONITOR DISPLAY	20
2. INSTALLATION	24
2.1 BASIC WIRING INSTRUCTIONS	25
2.2 HARD DISK DRIVE INSTALLATION	27
2.3 FINAL INSTALL PROCESS	27
2.4 QUICK INSTALLATION GUIDE FOR EDR810M & EDR410M ONLY	28
3. DVR MENU SETUP	33
3.1 TIME/DATE SETUP MENU	34
3.2 CAMERA SETUP MENU	38
3.3 RECORD SETUP MENU	42
3.4 ALARM SETUP MENU	44
3.5 MOTION SETUP MENU	47
3.6 VIDEOLOSS SETUP MENU	50
3.7 NETWORK SETUP MENU	52
3.7.1 CONFIG	52
3.7.2 ALARM NETWORK	55
3.7.3 EMAIL	56
3.7.4 PASSWORD	57
3.7.5 WIRELESS	58
3.7.6 PPPoE	60
3.7.7 DDNS	61
3.7.8 GPS	63
3.8 SCHEDULE SETUP MENU	64
3.9 DISK SETUP MENU	66
3.10 CONTROL SETUP MENU	68
3.11 WARNING SETUP MENU	70
3.11.1 FAN FAULT	70
3.11.2 HDD TEMP	71
3.11.3 NO HDD	73
3.11.4 HDD FULL	74
3.12 SYSTEM SETUP MENU	76
4. RECORDING OVERVIEW	79
4.1 INSTANT (N) RECORDING SETUP	79

4.2 SCHEDULE RECORDING SETUP.....	80
4.3 EVENT RECORDING SETUP.....	81
5. PLAYBACK OVERVIEW.....	84
5.1 BASIC PLAYBACK	84
5.2 SEARCH PLAYBACK	87
6. COPYING VIDEO	90
6.1 VIEWING A COPIED FILE	92
7. CALL OVERVIEW.....	93
8. SCREEN DISPLAY SETTING & MODE	94
8.1 MODE BUTTON	95
9. UPGRADE FIRMWARE.....	96
10. NETWORKING OVERVIEW.....	97
10.1 INTRODUCTION TO TCP/IP.....	97
10.2 SUBNET MASKS	97
10.3 GATEWAY ADDRESS	98
10.4 VIRTUAL PORTS	98
10.5 PRE-INSTALLATION	98
10.6 WHAT TYPE OF NETWORK CONNECTION DO YOU HAVE?.....	100
10.7 SIMPLE ONE TO ONE CONNECTION	101
10.8 DIRECT HIGH SPEED MODEM CONNECTION.....	107
10.9 ROUTER OR LAN CONNECTION	109
11. LINKSYS PORT FORWARDING.....	112
12. D-LINK PORT FORWARDING.....	116
13. EVERFOCUS DDNS SETUP.....	120
14. VIEWING THROUGH INTERNET EXPLORER.....	122
14.1 SEARCH.....	128
14.1.1 SEARCH BY TIME	128
14.1.2 SEARCH BY EVENT	129
14.2 PTZ CONTROL.....	130
14.3 REMOTE ARCHIVE.....	131
14.4 REMOTE CONFIGURATION.....	136
15. INTERFACE SPECIFICATIONS	143
15.1 TRANSMISSION SETTING	143
15.2 REMOTE CONTROL PROTOCOL.....	144

APPENDIX A: REMOTE CONTROL	147
APPENDIX B: ALARM BOARD CONFIGURATION.....	148
TROUBLESHOOTING.....	150

Safety Warning

WARNING

TO REDUCE RISK OF FIRE OR ELECTRIC SHOCK,
DO NOT EXPOSE THIS APPLIANCE TO RAIN OR MOISTURE.

CAUTION

DO NOT REMOVE COVER. NO USER SERVICEABLE PARTS
INSIDE.

Note:

This equipment has been tested and found to comply with the limits for a Class A digital device,
The changes or modifications not expressly approved by the party responsible for compliance could void the user's authority to operate the equipment.

Note:

This is a class A product. In a domestic environment this product may cause radio interference, in which case the user may be required to take adequate measures.

Notice:

The information in this manual was current when published.
The manufacturer reserves the right to revise and improve its products.
All specifications are therefore subject to change without notice.

Safety Precautions

- Refer all work related to the installation of this product to qualified service personnel or system installers.
- Do not block the ventilation opening or slots on the cover.
- Do not drop metallic parts through slots. This could permanently damage the appliance. Turn the power off immediately and contact qualified service personnel for service.
- Do not attempt to disassemble the appliance. To prevent electric shock, do not remove screws or covers. There are no user-serviceable parts inside. Contact qualified service personnel for maintenance. Handle the appliance with care. Do not strike or shake, as this may damage the appliance.
- Do not expose the appliance to water or moisture, not try to operate it in wet areas. Do take immediate action if the appliance becomes wet. Turn the power off and refer servicing to qualified service personnel. Moisture may damage the appliance and also cause electric shock.
- Do not use strong or abrasive detergents when cleaning the appliance body. Use a dry cloth to clean the appliance when it is dirty. When the dirt is hard to remove, use a mild detergent and wipe gently.
- Do not overload outlets and extension cords as this may result in a risk of fire or electric shock.
- Do not operate the appliance beyond its specified temperature, humidity or power source ratings. Do not use the appliance in an extreme environment where high temperature or high humidity exists. Use the appliance at temperature within indoor type DVR for 32°F ~ +104°F and a humidity below 90%. The input power source for this appliance is AC100~240V.

Safety Precautions

- **Read Instruction**
All the safety and operating instructions should be read before the unit is operated.
- **Retain Instructions**
The safety and operating instructions should be retained for future reference.
- **Heed Warnings**
All warnings on the unit and in the operating instructions should be adhered to.
- **Follow Instructions**
All operating and use instructions should be followed.
- **Cleaning**
Unplug the unit from the outlet before cleaning. Do not use liquid cleaners or aerosol cleaners. Use a damp cloth for cleaning
- **Attachments**
Do not use attachment not recommended by the product manufacturer as they may cause hazards.
- **Water and Moisture**
Do not use this unit near water-for example, near a bath tub, wash bowl, kitchen sink, or laundry tub, in a wet basement, near a swimming pool, in an unprotected outdoor installation, or any area which is classified as a wet location.
- **Servicing**
Do not attempt to service this unit by yourself as opening or removing covers may expose you to dangerous voltage or other hazards. Refer all servicing to qualified service personnel.
- **Power Cord Protection**
Power supply cords should be routed so that they are not likely to be walked on or pinched by items placed upon or against them, paying particular attention to cords and plugs, convenience receptacles, and the point where they exit from the appliance.
- **Object and Liquid Entry**
Never push objects of any kind into this unit through openings as they may touch dangerous voltage points or short-out parts that could result in a fire or electric shock. Never spill liquid of any kind on the unit.

1. Product Overview

EDR810/410 DVRs are the industry's first full-featured digital video recorder designed specifically for use within the security industry. EDR810/410 DVRs incorporates all the benefits of digital video recording, is simple to install, and operates just like a VCR. Highly efficient compression technology and superior resolution of recorded images make the Digital Video Recorder stand out from the competition as the best choice for security surveillance.

1.1 Features

- ➔ Duplex Operation for Recording & Playback
- ➔ Built-in MPEG4 Codec with Configurable Quality
- ➔ Variable Recording Speeds up to 60/50 Images per second for NTSC/PAL
- ➔ Audio Recording Capabilities
- ➔ Motion Detection Capabilities
- ➔ One 3.5" Hard Disk with Hot-Swap Tray for Internal Storage
- ➔ Ethernet Interface for Remote Network Viewing
- ➔ Optional Wireless LAN Interface for Data Transmission
- ➔ RS485 for Remote Control
- ➔ Shuttle/Jog Dial for Picture-by-Picture or Fast/Slow Viewing
- ➔ Easy-to-use Control Panel with Common VCR and Multiplexer Functions
- ➔ On-Screen Menus Operations with Multi-Language Support
- ➔ Real-Time Live Display for all Cameras
- ➔ Easy archiving of video and Remote Viewer through USB port
- ➔ Remote configuration function
- ➔ Remote Firmware Upgrade function
- ➔ Motion detection function can be scheduled according to user's setting
- ➔ For mobile models (ED810M/410M), GPS data can be sent out to receiver, for user to orientate the exact position

1.2 Specifications

Video format	NTSC or PAL
Video input	4/8 camera inputs (BNC), 1Vp-p/75ohm
Video output	1 BNC video out (1Vp-p/75ohm) for Main Monitor
	1 BNC video out (1Vp-p/75ohm) for Call Monitor
	4 BNC outputs (1Vp-p/75ohm) for Looping (4 Channels only)
Video compression	MPEG4
Recording resolution	720x240, 720x480 or 360x240 for NTSC
	720x288, 720x576 or 360x288 for PAL
Video display	Full, 4, 7, and 9 screen view for Live and Playback PIP and 2x2 Zoom for Playback only
Alarm inputs	4/8 Alarm Inputs
Alarm outputs	1 Alarm Output
Hard disk storage	One Hot-Swappable 3.5" IDE or SATA Hard Disk (2.5" hard disk available for mobile models)
Recording rate	Up to 120/100 Images per second for NTSC/PAL
Recording mode	Continuous, Schedule, Event (Motion and Alarm) recording
Playback rate	Up to 60/50 Images per second for NTSC/PAL
Playback search	By Date/Time or Event (Motion, Video Loss, Alarm)
Playback options	Play, Pause, Stop, Fast Fwd, Fast Rev, Slow Fwd, Slow Rev
Motion detection	Yes, with configurable detection grid & sensitivity per camera
Video Loss detection	Yes
Event Log	Yes
Setup	Menu Driven On Screen Display
User input device	Front panel keypad with Shuttle/Jog, IR Remote Control, EKB500 Keyboard (optional)
Timer	Built-in real time clock with Watch Dog function and Auto Time Synchronization through NTP server
Title	12-characters title for each camera
Ethernet	RJ45 connectors for network communication
Archive	USB port for flash memory or external DVD drive
RS-232	9-pin female connector for testing purpose only
RS-485	for Keyboard or PTZ connection
Audio	1 set of stereo inputs, 1 set of stereo outputs
Power rate	12~24 VDC
Dimensions	Inches: 11.7 (L) x 8.3 (W) x 3.5 (H)
	Millimeters: 296.9 (L) x 211.1 (W) x 88.9 (H)
Weight	4 kg (approximately 8.8 lbs)
Operating temperature	0°C ~ 40°C (32 °F~104°F)

1.3 Front Panel Keypads

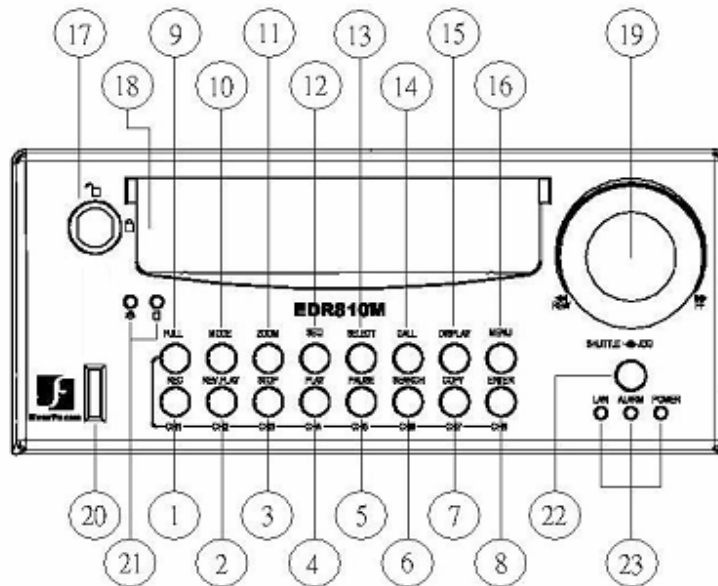

Keys:

- ❑ ~ ❏ **Channel Key:** Press **FULL**+Channel Key (**CH1~CH8**) to display video image in the full screen format; the picture of the corresponding channel will fill the whole screen.
- ❑ **CH1 / REC:** Press this key to start instant recording.
- ❑ **CH2 / REV. PLAY:** Reverse Play Back.
- ❑ **CH3 / STOP:** Press this key to stop recording and playing back.
- ❑ **CH4 / PLAY:** Play Back.
- ❑ **CH5 / PAUSE:** Press this key to pause the playback picture.
- ❑ **CH6 / SEARCH:** Press this key to enter the **SEARCH MENU**.
- ❑ **CH7 / COPY:** Press this key to enter the **COPY MENU**. If pressed while in playback mode, it is also used to bookmark copy time.
- ❑ **CH8 / ENTER:** Press this key to enter items, or jump to next subentry in the menu setting.

Ⓞ **FULL:** Press this key and channel Key at the same time to switch to full screen in both live mode and play back mode. Press “**MODE**” to exit full screen.

Ⓚ **MODE:** Switch PIP (Live only), 4, 7 and 9 displays in **Live** and **Playback** modes.

Ⓛ **ZOOM:** In full screen mode, 2x electronic zoom. Zoom screen can be moved through **JOG**. **ENTER** key changes the direction. Press the zoom key again to switch the electronic zoom off.

In multiscreen mode: Screen adjustment. Use the **JOG** to adjust the image to the fit the monitor. **ENTER** switches between horizontal and vertical adjustment. Press the zoom key again to switch the screen adjustment off.

Ⓜ **SEQ:** Press this key to enter the auto sequential switching mode.

Ⓝ **SELECT:** In multi-screen, press this key to assign cameras to different screens; in single screen, use it to adjust display properties. In menus, press this key to select certain features.

Ⓞ **CALL:** Press this key to enter and set up **CALL MENU**.

Ⓟ **DISPLAY:** Press this key to switch display of channels and/or status bar.

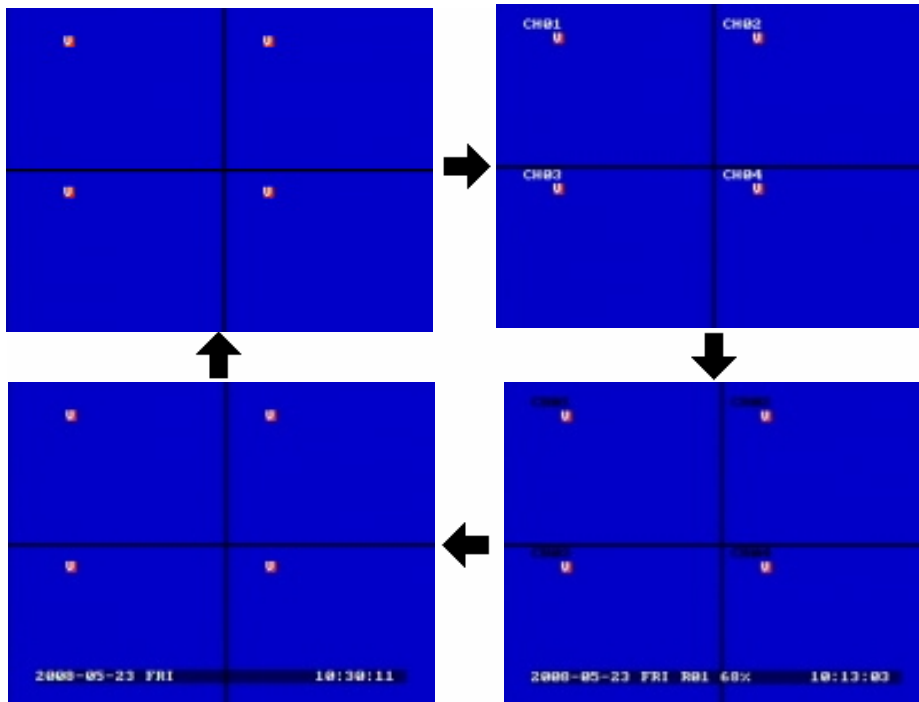

Ⓞ6 **MENU:** Press this key to enter or exit **MAIN SETUP MENU** or to exit from any submenu.

Ⓞ7 **HDD Lock:** Keeps HDD in place and turns on HDD power.

Ⓞ8 **Hard Disk Tray:** Hard Disk holder for HDD.

Ⓞ9 **Shuttle and Jog Dial**

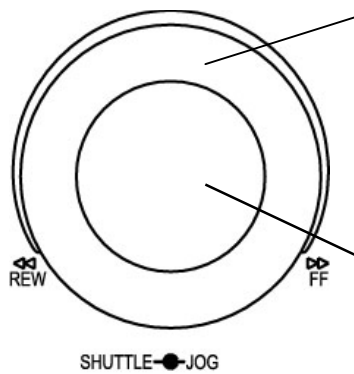

Shuttle:

In the **Playback** mode, turn the **Shuttle** dial to fast forward/rewind the video.

In the **Pause** mode, turn the **Shuttle** dial to slow forward/rewind the video.

In the event list, turn the **Shuttle** to change pages.

Jog Dial:

In the **Menu** mode, turn the **Jog** dial to change settings and values in subentries. In the **Pause** mode, turn the **Jog** dial to forward/rewind the video frame by frame.

Ⓞ0 **USB Slot:** USB port allows you to archive video files or upgrade the DVR software.

Ⓞ1 **HDD LEDs:** LEDs for HDD active power (GREEN) and data reading /writing (YELLOW).

Ⓞ2 **Remote Control:** Receiver for IR remote control.

Ⓞ3 **System LEDs:** LEDs for system active **LAN**, **ALARM** and **POWER** display.

1.4 Back Panel Connections

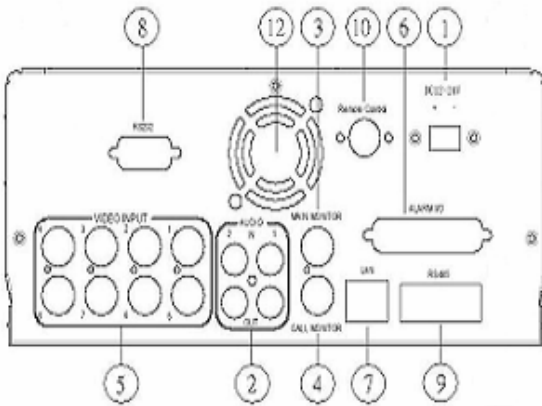

Back panel of 810H

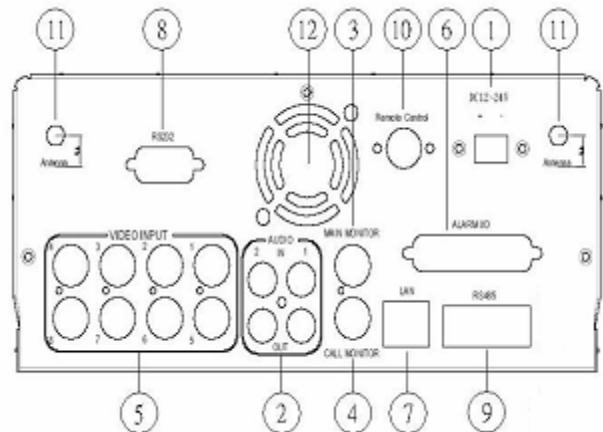

Back panel of 810M

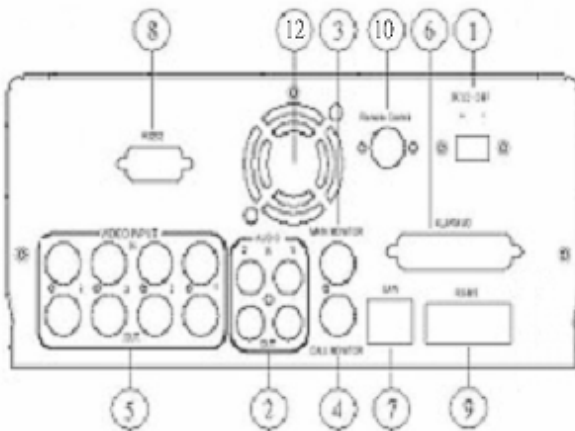

Back panel of 410H

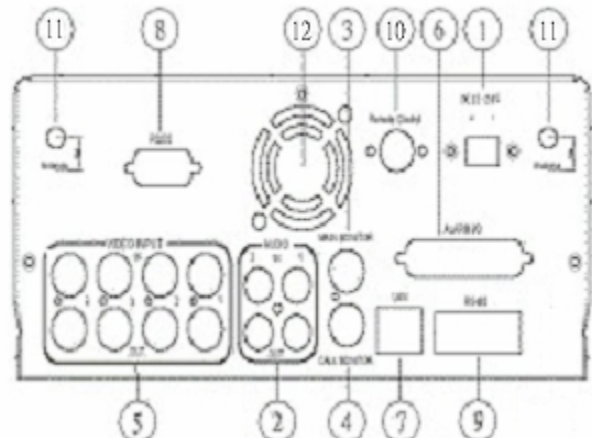

Back panel of 410M

POWER

- ① **Main Power plug:** Connect the DC 12~ 24V power source to adapter for AC 100~ 240V.
- ② **Audio IN:** Audio input for recording, and it can be set to “YES” or “NO” in the **RECORD SETUP MENU**.
Audio OUT: Connect an audio output to a monitor or other device.

MONITOR

- ③ **MAIN MONITOR:** This connector is used for the main monitor display, a number of different display modes may be selected for viewing.
- ④ **CALL MONITOR:** This connector is used for the call monitor. This monitor can only display a full screen picture.

VIDEO CONNECTIONS

- ⑤ **For EDR810 Series:**
VIDEO IN(1~8): BNC video inputs.
- For EDR410 Series:**
VIDEO IN(1~4): BNC video inputs
VIDEO OUT(1~4): BNC loop-through outputs

ALARM INPUT/OUTPUT

- ⑥ **ALM-INPUT:** Normal open or normal close type alarm signal inputs.
The Alarm Input can be selected as Normal Open (**N.O.**), Normal Close (**N.C.**), **N.C. TRANS.**, or **N.O, TRANS** input in the **ALARM SETUP MENU**.
When an alarm occurs, alarm recording will automatically start.

ALM-OUTPUT: A built-in relay offers 3 nodes which are **ALM-COM** (common), **ALM-NO** (normal open) and **ALM-NC** (normal close) for external use. *Note: Please check APPENDIX C to see other available alarm input/output functions.*

LAN

☞ **LAN Connector:** RJ-45 network connection.

RS232

☞ **RS232 connector:** D-Sub 9-pin connector to RS232 ports for testing purpose ONLY.

RS485

☞ **RS485 connector:** RJ 45 Connector to cascade/control multi Digital Video Recorders.

Remote

☞ **Remote Control:** Remote control port allows for an extension wire with an IR receiver instead of the IR receiver on the front panel.

Note: The IR receiver extension line (10m) must be purchased separately.

Wireless LAN

☞ **Antenna:** Integrated IEEE 802.11b/g wireless LAN capabilities. The antenna port is for wireless network antenna use (For EDR 410M and 810M only).

Fan

☞ **Fan:** Cooling fan.

1.5 Monitor Display

The status information of the cameras or machine will show up, and be located at different places on the screen.



For mobile model only:



❏ **Channel tag:** A channel tag indicates the channel name of the screen.

❏ **Event sign:** Event signals which are small icons with a capital letter and red background show the events on each screen. There are a total of 6 different signals:

A Alarm event.
Alarm event shows on a channel if an **ALARM** is enabled for that camera in the **ALARM SETUP MENU** and an alarm is triggered.

M Motion event.
Motion event only shows up when the camera's **MOTION** is enabled in **MOTION SETUP MENU** and the camera detects movement.

V Video loss event.
Video loss event only shows when the camera's **VIDEOLOSS** is enabled in **VIDEOLOSS SETUP MENU** and the camera signal is lost.

S Sequence sign.
Sequence sign shows up when the display is in sequence mode.

The last display on the screen has a "*" sign in the top-middle. The **S** sign will replace the "*" in the display when sequence occurs.

Note: Sequence cannot be activated when the multi-screen display is showing all cameras.

T Temperature indication.
This shows if the hard drive's temperature is overheated.
Overheat temperature is determined in **HDD TEMPERATURE** of **WARNING SETUP MENU**.

F Fan fail indication.
This shows when the fan fails to work normally. If you get this warning, contact technical support for assistance.

❏ **Select sign:** You can assign a camera to a display by pressing **SELECT** key in live mode. Dial **Jog** to move the select sign to the display you would like to change, and then press the desired channel key from the front panel to move that channel to that screen. Press **SELECT** again to exit from this mode.

❏ **Play status bar:** The play status bar appears in play back mode if the status bar is enabled (see **DISPLAY**, 8th item of **Front Panel Keypads**). There are three parts that will be shown: **play date**, **play status**, and **play time**.

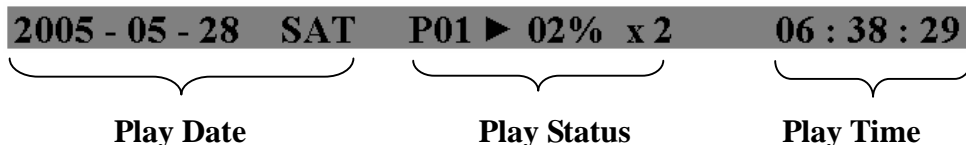

1. **Play date**

The date on which the video was recorded.

2. **Play status**

“PAUSE”, when the video playback is paused.

“P## >” means normal play speed on the displayed disk number;

“P## <” means normal reverse play speed on the displayed disk number;

“##%” shows the position on the Hard Drive;

“>> x N” means N time fast play speed;

“<< x N” means N time fast reverse play speed.

3. **Play time**

The play time at which the video is recorded. The time format depends on the setting in the **TIME/DATE SETUP MENU**.

☞ **Record status bar**

The record status bar appears when you enable a status bar on the screen.

There are four parts: current date, record status, event, and current time.

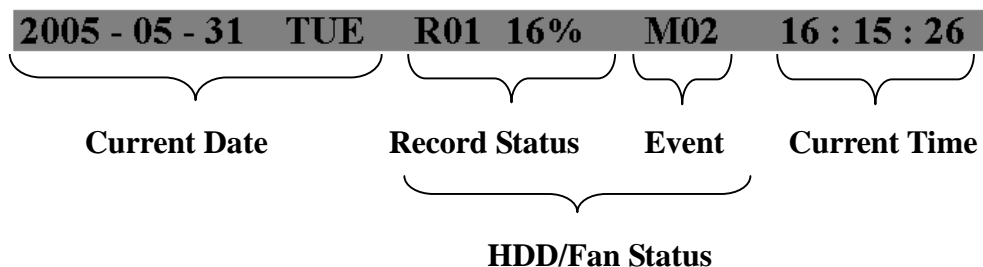

1. **Current date**

The current date which is set in the **TIME/DATE SETUP MENU**.

2. **Record status**

Displays current Hard Drive and record position.

R01: currently recording on Disk 1

16%: currently recording at 16% of total HD position

***NOTE:** Percentage only indicates the physical point of recording on the Hard Drive, not the total disk space used. To review the total amount of recording time, please refer to the Disk Menu (Chapter 3.9)*

3. **Event**
The current/last event that occurred.
4. **Current time**
The current time, which can be set in the **TIME/DATE SETUP MENU**.
5. **HDD/FAN status**
“**No Disk**”: only shows when no disk is installed or detected.
“**No Fan**”: only shows when internal fan stops working.
“**HDD OT**”: only shows if hard drive is over temperature.

⌚ **GPS orientation**

When GPS data is sent out to receiver, the exact position will be located by showing vehicle's longitude and latitude.

2. Installation

The installations described below should be done by qualified service personnel or system installers.

I) PACKING

Please check accessories in the packing before the installation.

II) SYSTEM FLOORPLAN

Please refer to the following diagrams for the system connections.

Note: Monitor and Camera must be purchased separately.

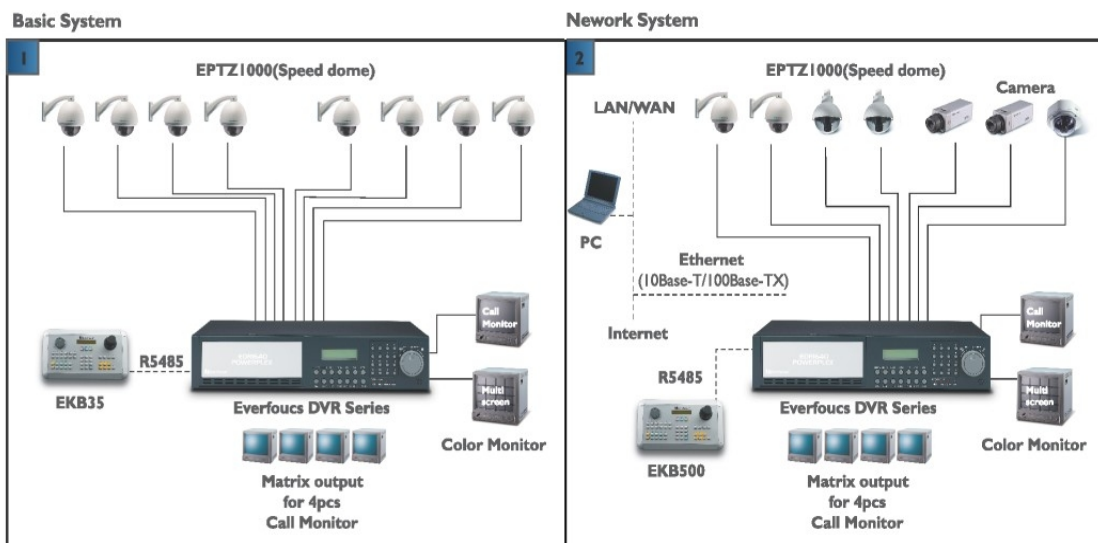

Diagram 2.1

2.1 Basic Wiring Instructions

Please refer to diagram 2.1 to assist you with this portion of the installation.

1. Power

Connect the power source or adapter into the power socket.

2. Cameras

Connect each camera's video output to the video inputs on the digital video recorder.

Note: At least one camera must be connected before the system is running for the auto detection of video standard to take effect.

3. Audio Input

The camera audio output or Microphone is connected to the audio input terminal at the rear panel.

4. Audio Output

Connect the speaker or other audio listening devices to the audio output terminal on the back of the digital video recorder.

5. Ethernet

The digital video recorder may be viewed from a PC via the LAN connector using a RJ45 Ethernet cable.

6. RS485

The digital video recorder can be controlled from an EKB500 keyboard via RS485.

Note: This can be done using a RJ45-to-serial cable.

7. Main Monitor

Connect a monitor to the main monitor output connector. The main monitor displays live or recorded cameras in any available format.

Note: The main monitor must be connected in order to make configuration changes, enter the main menu, or do a playback at the machine.

8. Call Monitors

Connect the call monitor output connectors to a call monitor. The call monitor display selected live cameras in full screen format.

Note: The call monitor will only display one full screen camera at a time.

2.2 Hard Disk Drive Installation

The first step in installing the hard drive is to insert the hard drive sleeve into the machine. The hard disk drive default setting is initially set to master. The second step is to insert the key provided and turn the tray key to the lock position. If this process is ignored the hard disk drive will not be detected.

- ***Note: If the Hard Disk Drive is not locked in with the key, HDD LED will not light up and the DVR will not go into record mode. This is because the Hard Drive is not being recognized.***
- ***Note:*** After powering on the DVR, it will start to load system. It takes a while to complete loading system, during this time, please do not install or remove the hard disk. No action is recommended while the machine is loading system.

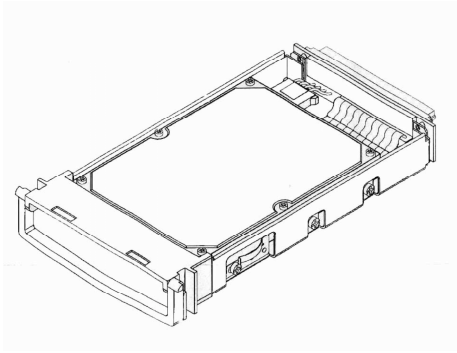

Diagram 2.2 shows 3.5" Hard Drive

2.3 Final Install Process

Once you have completed the basic wiring installation and the hard disk drive installation you are ready to turn on the DVR. Simply plug the power source you installed earlier. The POWER LED lights will light up if power is normal. The next step is to set up the menu options for the DVR.

2.4 QUICK INSTALLATION GUIDE FOR EDR810M & EDR410M ONLY

The EDR810M & EDR410M are the full-featured digital video recorders designed specifically for use in mobile applications. Please refer to the following Quick Installation Guide for installing EDR810M or EDR410M into mobile applications such as buses, cars and police cruisers.

- The DVR can be mounted horizontally (suspend or support mounted).

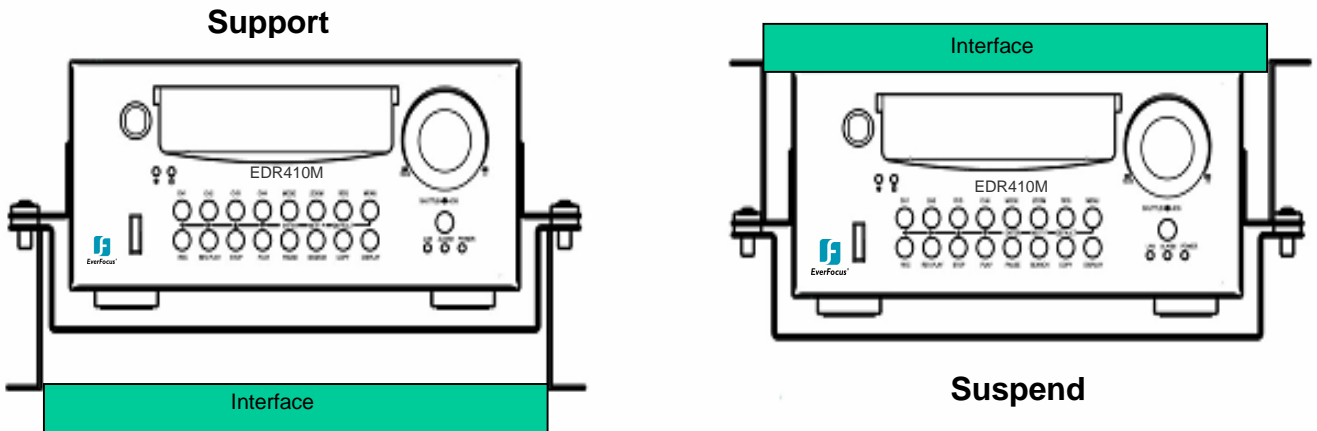

- Show all the possible ways to mount the DVR.
Use the two Z-brackets supplied to mount it in any ways shown.

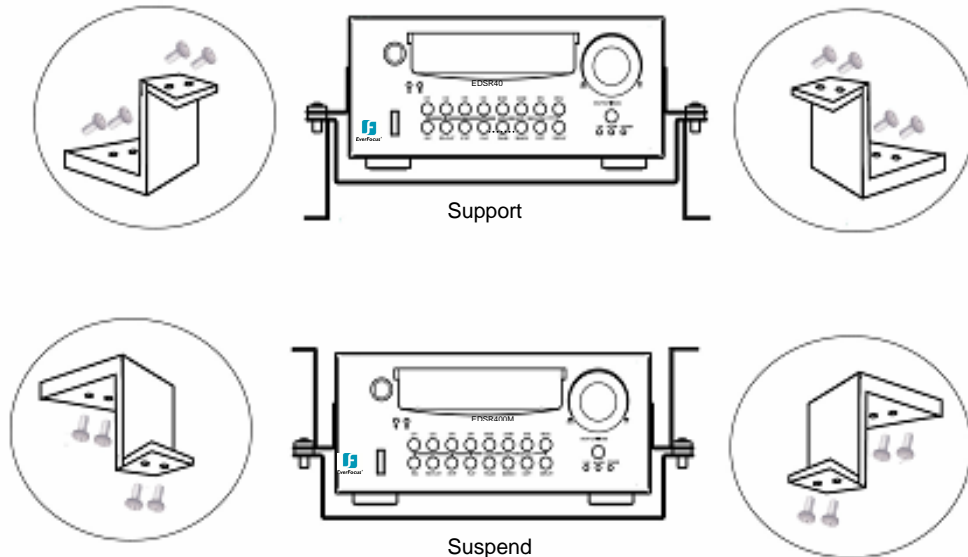

□ Unpack Everything

Make sure you have everything you need before you begin the installation.

□ Equipment Required

The following tools may help you to complete the installation:

- Drill
- Screwdrivers
- Wire cutters

□ Choosing the Location Choose a location for installation that:

- Provides convenient access for installing or removing the hard drive
- Allows air to flow around the fan vents. Inadequate or improper air flow can impede proper operation of the unit

Avoid any location for installation:

- That is subject to high vibration
- That is subject to high sunlight levels
- That is subject to drenched of the rain
- Where passengers can interfere with unit
- Next to a heater duct

The following table lists the recommended location options.

Location	Convenient operation	Easy to install	Low vibration	Good air flow
Bottom of glove box- horizontal mount	Yes	Yes	Yes	Yes
Bottom of passenger seat next to the driver	NO	Yes	Yes	Yes
Underneath bulkhead-horizontal mount	Yes	Yes	NO	Yes
Front of bulkhead-horizontal mount	Yes	Yes	Yes	Yes
Beside driver seat-horizontal mount	Yes	Yes	Yes	Yes

Caution: Do not install the DVR on the floor or on the transmission access hatch. These locations have the highest levels of vibration and may be subject to water damage.

□ **Possible Installation Locations Inside the Automobile Vehicle: Truck**

Glove box (inside or underneath)

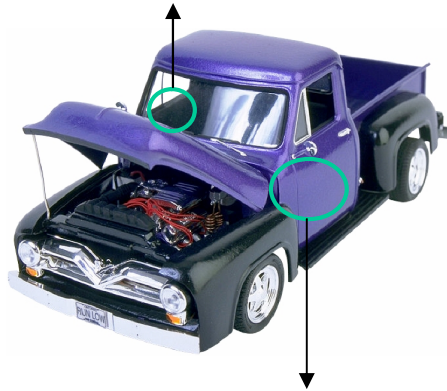

Drive seat (between seat and wall) or Passenger seat (underneath)
(Users are suggested to use “support” for mounting option)

□ Show the wiring on the wiring harness that connects to the electrical system.

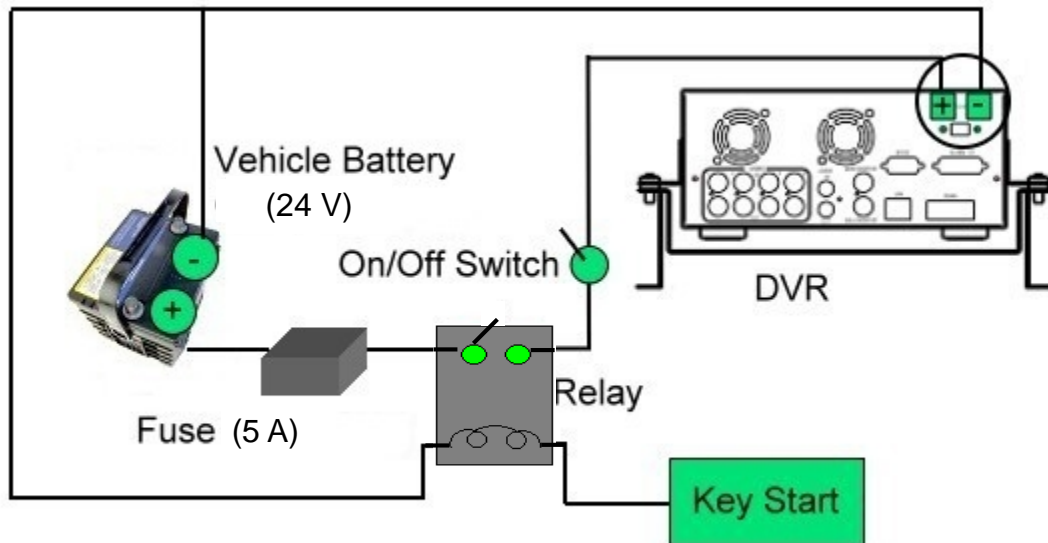

□ Possible Installation Locations Inside the Automobile Vehicle: TOYOTA CAMRY

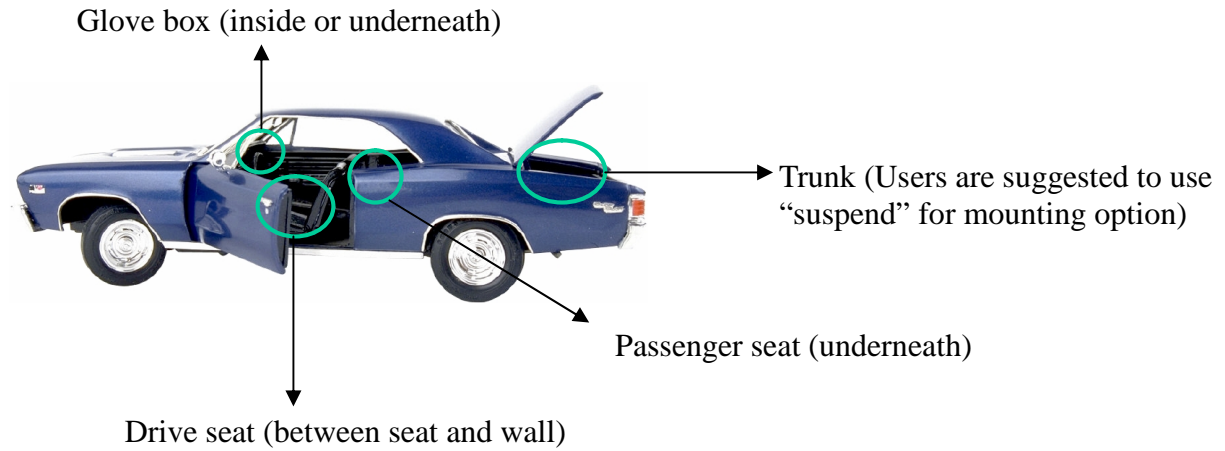

□ Show the wiring on the wiring harness that connects to the electrical system.

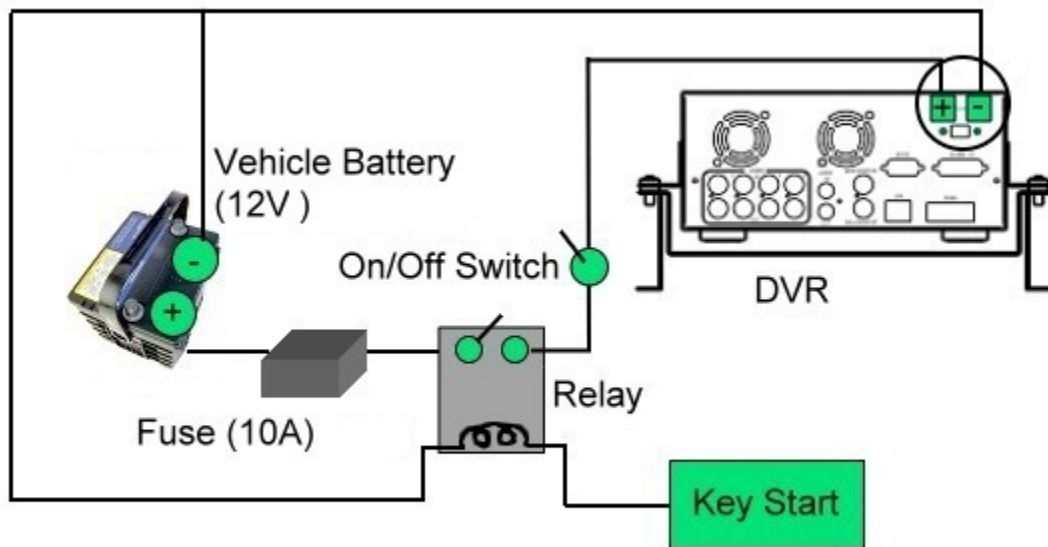

□ **Installing the Camera(s) and Monitor**

The DVR is typically connected to one camera installed inside the car. Other camera(s) can also be installed in different locations (for example, use the waterproof camera to the outside of vehicle). For installation procedure, please refer to the guide that came with the camera(s) you purchased.

The Monitor power supply connects from the Automotive adapter (cigarette plug)
Monitor and cameras must be purchased separately.



□ **Connect the Camera(s)** Connect the power connector from the camera(s) harness into the CAMERA POWER OUT jack on the back panel of the DVR.

Connect the primary camera(s) video connector to the CAMERA INPUT and the audio connector to the AUDIO INPUT in the back panel.

Adjust the camera(s). After the camera is installed, connect a monitor directly to the camera and observe the image.

Make any adjustment if necessary.

3. DVR Menu Setup

Assuming you have completed the first two chapters of this manual, you are now ready to begin setting up the digital video recorder. The following chapter will walk you through the detailed DVR Menu step by step and how to set the DVR for your specific application. To begin this process, press the **MENU** key. Once inside the Main Menu you will find there are 12 setup option pages as follows.

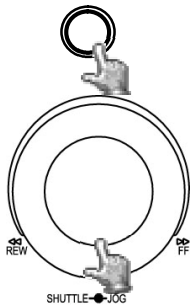

Press the **MENU** key to enter or exit the **MAIN SETUP MENU**.
Press the **MENU** key in any sub-menu to go back to previous screen.

Dial the **Jog** clockwise or counterclockwise to scroll through the **MAIN MENU** options or to change subentry values.

Press the **ENTER** key to go to the next subentry in a menu setting.

Press the **DISPLAY** key to go to the previous subentry in a menu setting.



Diagram 3.1

3.1 Time/Date Setup Menu

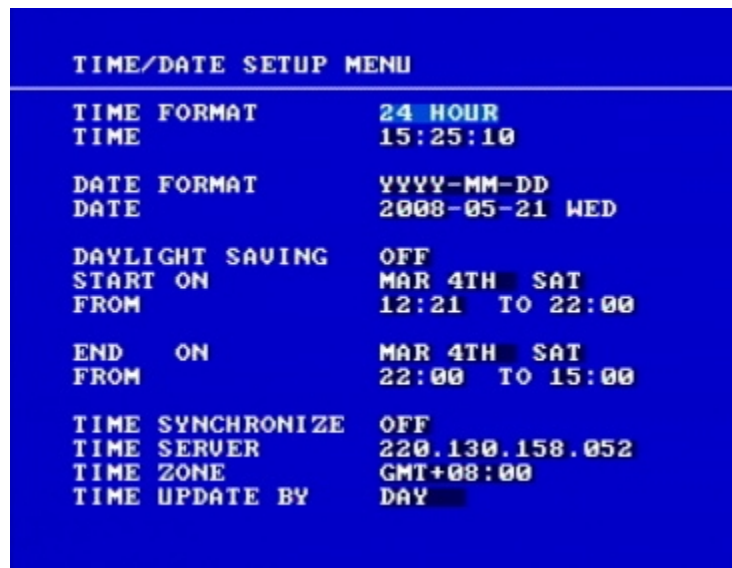

TIME/DATE SETUP MENU	
TIME FORMAT	24 HOUR
TIME	15:25:10
DATE FORMAT	YYYY-MM-DD
DATE	2008-05-21 WED
DAYLIGHT SAVING	OFF
START ON	MAR 4TH SAT
FROM	12:21 TO 22:00
END ON	MAR 4TH SAT
FROM	22:00 TO 15:00
TIME SYNCHRONIZE	OFF
TIME SERVER	220.130.158.052
TIME ZONE	GMT+08:00
TIME UPDATE BY	DAY

Diagram 3.2

Diagram 3.2 is a screenshot of the **TIME/DATE SETUP MENU**. This menu is used to set up the correct time and date for your region of the world. You are able to setup daylight savings as well as synch it with an internet based time server. In the **TIME/DATE SETUP MENU** the following fields are defined as follows:

1. **TIME FORMAT:** This field represents the time format on the DVR. You can select between **12 HOUR** and **24 HOUR** format.
2. **TIME:** This field represents the current time on the DVR. To change this, turn the Jog Dial on the DVR.

The Time is represented as follows:

Hour: 00~23 (1 ~ 12 if TIME FORMAT is 12 HOUR): Minute: 00~59: Second: 00~59

3. **DATE FORMAT:** This field represents the date format on the DVR. To change this, simply use the Jog Dial on the DVR. There are three date formats to select from: **YYYY-MM-DD**, **MM-DD-YYYY** and **DD-MM-YYYY**.
4. **DATE:** This field represents the date on the DVR. To change this, turn the Jog Dial on the DVR. The day of the week automatically adjusts according to the other settings.

By default, the date is represented as follows:

Year: 2000~2037 / Month: 01~12 / Date: 01~31 (Day of Week)

5. **DAYLIGHT SAVING:** This field represents the daylight savings on the DVR. To change this, simply use the Jog Dial on the DVR. Select “ON” or “OFF” to enable or disable daylight saving time function. This feature must be disabled in order to make any changes to the start and end times.

6. **START TIME:** To set the beginning of daylight saving time.

To set the start month of daylight saving time: Dial the jog to set the start month.



To set the start week of daylight saving time: Dial the jog to set the start week.



To set the start date of daylight saving time: Dial the jog to set the start date.



To set the starting time change of daylight saving time: Choose the “FROM” time and “TO” time when daylight savings starts.

7. **END TIME:** To set the end of daylight saving.

To set the end month of daylight saving time: Dial the jog to set the end month.



To set the end week of daylight saving time: Dial the jog to set the end week.



To set the end date of daylight saving time: Dial the jog to set the end date.



To set the ending time change of daylight saving time: Choose the “FROM” time and “TO” time when daylight saving time ends

8. **TIME SYNCHRONIZE:** Select “ON” or “OFF” to enable or disable time synchronize which will automatically update the DVR’s time when connected to a network. To change this, simply use the Jog Dial on the DVR.
9. **TIME SERVER:** You can set the time server address that the DVR connects to for time synchronize. To determine the IP address of NTP Server, please follow these steps:
 - a) Go to a PC that is connected to the internet.
 - b) Click on “START” -> “RUN” -> type “cmd” and press “OK”.
 - c) In the Dos Prompt, type “ping pool.ntp.org” to find out the IP address of an NTP Server.

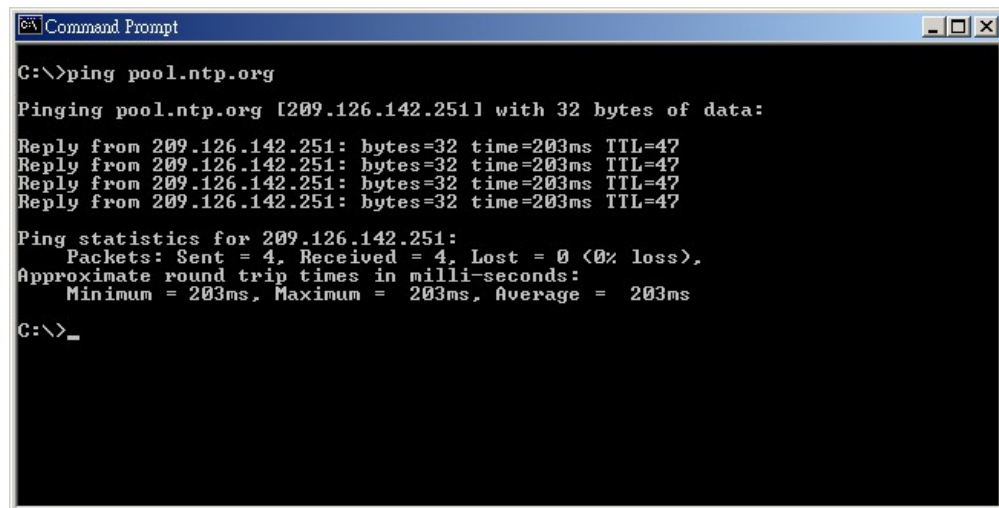

```
Command Prompt
C:\>ping pool.ntp.org
Pinging pool.ntp.org [209.126.142.251] with 32 bytes of data:
Reply from 209.126.142.251: bytes=32 time=203ms TTL=47
Reply from 209.126.142.251: bytes=32 time=203ms TTL=47
Reply from 209.126.142.251: bytes=32 time=203ms TTL=47
Reply from 209.126.142.251: bytes=32 time=203ms TTL=47
Ping statistics for 209.126.142.251:
    Packets: Sent = 4, Received = 4, Lost = 0 (0% loss),
    Approximate round trip times in milli-seconds:
        Minimum = 203ms, Maximum = 203ms, Average = 203ms
C:\>_
```

Diagram 3.3

9. **TIME ZONE:** You can set the time zone that the DVR adjusts to when updating from the time server.

Atlantic Daylight Time subtract 3 hours from GMT
Atlantic Standard Time subtract 4 hours from GMT
Eastern Daylight Time subtract 4 hours from GMT
Eastern Standard Time subtract 5 hours from GMT
Central Daylight Time subtract 5 hours from GMT
Central Standard Time subtract 6 hours from GMT
Mountain Daylight Time subtract 6 hours from GMT
Mountain Standard Time subtract 7 hours from GMT
Pacific Daylight Time subtract 7 hours from GMT
Pacific Standard Time subtract 8 hours from GMT
Alaska Daylight Time subtract 8 hours from GMT

Alaska Standard Time subtract 9 hours from GMT
Hawaii-Aleutian Daylight Time subtract 9 hours from GMT
Hawaii-Aleutian Standard Time subtract 10 hours from GMT

11. **TIME UPDATE BY:** Once you enable the **TIME SYNCHRONIZE**, you can select the synchronization frequency by:

DAY

WEEK

MONTH

3.2 Camera Setup Menu

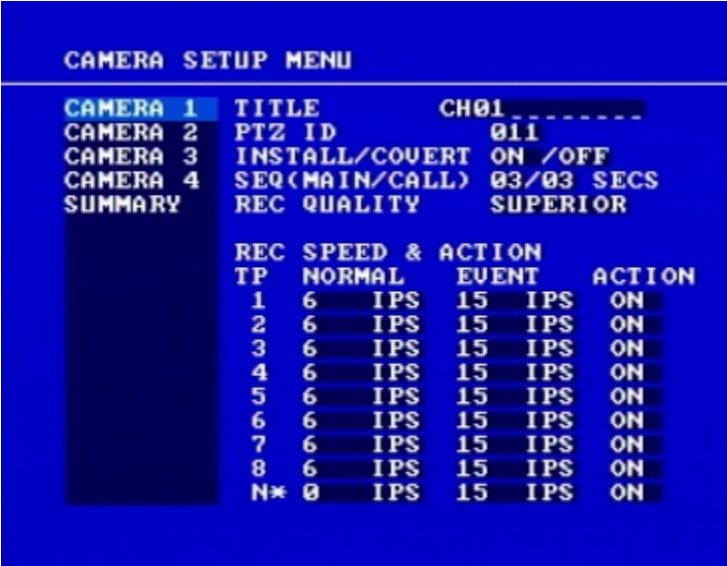

The screenshot shows a blue background with white text. At the top, it says 'CAMERA SETUP MENU'. Below that, there are four camera entries: CAMERA 1, CAMERA 2, CAMERA 3, and CAMERA 4. Each entry has a 'TITLE' field, a 'PTZ ID' field, an 'INSTALL/COVERT' field, and a 'SEQ(MAIN/CALL)' field. Below these entries is a 'SUMMARY' section with 'REC QUALITY' set to 'SUPERIOR'. At the bottom, there is a table for recording speeds and actions.

CAMERA	TITLE	CH01
CAMERA 1		
CAMERA 2	PTZ ID	011
CAMERA 3	INSTALL/COVERT	ON /OFF
CAMERA 4	SEQ(MAIN/CALL)	03/03 SECS
SUMMARY	REC QUALITY	SUPERIOR

REC	SPEED & ACTION		
TP	NORMAL	EVENT	ACTION
1	6 IPS	15 IPS	ON
2	6 IPS	15 IPS	ON
3	6 IPS	15 IPS	ON
4	6 IPS	15 IPS	ON
5	6 IPS	15 IPS	ON
6	6 IPS	15 IPS	ON
7	6 IPS	15 IPS	ON
8	6 IPS	15 IPS	ON
N*	0 IPS	15 IPS	ON

Diagram 3.4

Diagram 3.4 is a screen shot of the **CAMERA SETUP MENU**. This menu will walk you through setting up the Camera Recording Speeds, Camera Titles, PTZ ID, covert modes, and recording quality. In the **CAMERA SETUP MENU** the following fields are defined as:

1. **TITLE:** The title setting allows you to assign a title to each camera input. Each channel supports a title with up to 12 characters. Press Enter to move to each character and use the Jog Dial to change the value. The available alphanumeric characters are:

0,1,2,3,4,5,6,7,8,9,

A,B,C,D,E,F,G,H,I,J,K,L,M,N,O,P,Q,R,S,T,U,V,W,X,Y,Z,

() . , + - / and an empty space.

2. **PTZ ID:** Select PTZ ID/Address from 001~255 or OFF. OFF is the same as 000. The default value is 10+N where N is camera's number. This ID must be the same as the ID used in PTZ Dip Switch. To change this, simply use the Jog Dial on the DVR.
3. **INSTALL/COVERT:** Select "ON" to enable a camera, and "OFF" to disable it. All recording must be stopped before making changes to **INSTALL**. To take full advantage of the DVR's recording ability, switch any unused Camera Ports to OFF in this section. For **COVERT**, select "ON" to cover a camera, and disable the screen in live mode. However, the image is still recorded, and can be played back by any user that has playback right. The covert channels will not show up in the sequence mode. To make changes, simply use the Jog Dial on the DVR.

4. **SEQ (MAIN/CALL):** Set the number of seconds a camera is displayed in sequence. The first number is for sequence on the Main Monitor, the second number is for sequence on Call Monitor.
5. **REC QUALITY:** Select an image quality for recording. There are six different qualities available. A higher image quality uses more HDD space. To change this, simply use the Jog Dial on the DVR. The approximate space needed per second is listed below:

720x480		Video Source	
		Simple:	Complex:
Average size per image	LOWER:	8.04KB	12.33KB
	LOW:	8.42KB	13.7KB
	BASIC:	10.15KB	16.72KB
	STANDARD:	11.86KB	19.56KB
	HIGH:	14.72KB	24.63KB
	SUPERIOR:	18.60KB	30.05KB
720x240		Video Source	
		Simple:	Complex:
Average size per image	LOWER:	3.53KB	7.82KB
	LOW:	3.87KB	8.36KB
	BASIC:	4.21KB	8.9KB
	STANDARD:	4.92KB	9.54KB
	HIGH:	5.62KB	10.17KB
	SUPERIOR:	6.41KB	12.89KB
360x240		Video Source	
		Simple:	Complex:
Average size per image	LOWER:	1.76KB	4.56KB
	LOW:	1.87KB	4.87KB
	BASIC:	1.97KB	5.46KB
	STANDARD:	2.38KB	6.51KB
	HIGH:	2.67KB	7.08KB
	SUPERIOR:	3.63KB	9.02KB

Note: “Simple” refers to very few changes occurring during recording; “Complex” means the whole image is constantly changing. Since the compression ratio of MPEG4 fully depends on the variation and complexity of the recorded video, the table above is for reference only.

6. REC SPEED & ACTION:

TP: Scheduled recording time 1~8 which can be set in the **SCHEDULE SETUP MENU**. “N” is the normal recording time, which is activated by pressing the Record button. If you have set a Time Period in Schedule Setup Menu, then there will be a star sign (*) beside that TP in Camera Setup Menu.

NORMAL: Normal record speed up to 15 IPS (images per second). The default normal record speed is 1 IPS. EDR810/410 will adjust to the maximum recording speed by calculating the total installed cameras that have been enabled in the **CAMERA SETUP MENU**.

EVENT: Event record speed (Images per second) up to 30 IPS or “**OFF**”.

***Note:** In order to activate a new record speed, you need to disable all current record actions and then turn them back on.*

ACTION

Set “**ON**” to activate motion action on a selected Time Period.

Set “**OFF**” to disable motion action on a selected Time Period.

This setting correlates closely with Motion Setup. If motion setting is disabled, motion detection will not function regardless if TP (Time Period) Action in Camera Setup Menu is ON or OFF.

However, if Motion setting is **enabled**, then motion detection function works depending on **Action** setting in Camera Setup Menu. All motion actions (including buzzer, relay, network alarm, e-mail and log) will be triggered if they are enabled in Motion Setup Menu as long as Action is “**ON**” for the TP (Time Period) you have set. If you do not wish to have motion detected for a specific time, set Action “**OFF**” for that Time Period. This function gives you flexibility to set the motion detection feature ON or OFF for different Time Periods.

7. SUMMARY:

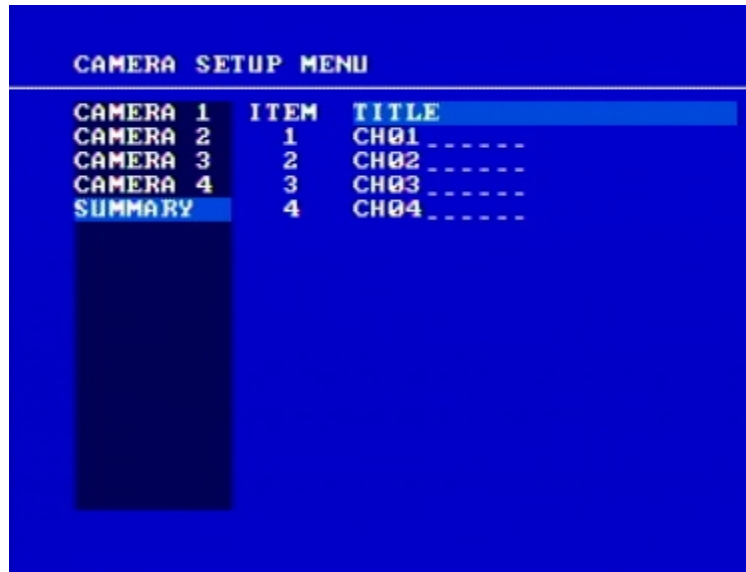

The screenshot shows a blue background with white text. At the top, it says 'CAMERA SETUP MENU'. Below that is a table with three columns: CAMERA, ITEM, and TITLE. The rows are: CAMERA 1, CAMERA 2, CAMERA 3, CAMERA 4, and SUMMARY. The SUMMARY row is highlighted in blue. The TITLE column contains CH01, CH02, CH03, and CH04, each followed by a dashed line.

CAMERA	ITEM	TITLE
CAMERA 1	1	CH01 -----
CAMERA 2	2	CH02 -----
CAMERA 3	3	CH03 -----
CAMERA 4	4	CH04 -----
SUMMARY		

Diagram 3.5

Dial **Jog** to change items in the **SUMMARY** table.

All cameras' statuses are shown in the **SUMMARY** table. The table is for checking camera overall statuses only, not for changing them.

Note: The SUMMARY table also exists in ALARM, MOTION and VLOSS SETUP MENU. All of these SUMMARY tables are also for checking particular overall statuses, not for changing them.

8. Copy camera's setting from a camera to other cameras: In order to copy the setting from a camera to other cameras, we provide a setting copy function. Press **MENU** when you finish setting up a camera, and then press **COPY**. The word "**COPIED**" will show up in the top right corner of the screen, and it means the settings have been copied. Dial the **Jog** to the camera you would like to copy to, and then press **SEARCH**. The settings of the first camera will be copied to the next one, and "**PASTED**" will show up in the top right corner.

NOTE: TITLE, PTZ ID, and INSTALL/COVERT cannot be copied. These 3 options need to be set independently.

3.3 Record Setup Menu



Diagram 3.6

Diagram 3.6 is a screen shot of the **RECORD SETUP MENU**. This menu is for setting up the options for recording. In the **RECORD SETUP MENU** the following fields are defined as follows:

1. **RECORD AUDIO:**

YES: Audio will be recorded when machine is recording and a microphone is connected.

NO: Audio will not be recorded when machine is recording.

2. **TIME STAMP:**

ON: The time stamp will show on both the live and recorded video.

OFF: The time stamp will not show on the live or recorded video.

3. **TIME STAMP POSITION:**

BOTTOM: The time stamp will show on the bottom.

TOP: The time stamp will show on the top.

4. **WATER MARK:**

ON: Recording is overlaid by a visible watermark (“W”).

OFF: No watermark.

5. **RESOLUTION:** The resolutions for NTSC are 720x480, 720x240 and 360x240; the default value is 720x240. The resolutions for PAL are 720x576, 720x288 and 360x288; the default value is 720x288.

NOTE: The resolution determines the maximum record speed supported by the DVR.

NTSC

720x480 = 30 IPS (this IPS value is divided by the amount of cameras installed)

720x240 = 60 IPS (this IPS value is divided by the amount of cameras installed)

360x240 = 120 IPS (this IPS value is divided by the amount of cameras installed)

6. **RECORD MODE:**

REWRITE: Continue recording. Disk will begin overwriting if it is full.

STOP: Stop recording when disk is full.

7. **AUTOWRITE WITHIN:** You can set DVR to automatically overwrite after the selected number of days. If you do not wish to use this function, simply select “0”.

8. **PRE-ALARM RECORDING**

Select “YES” to enable pre-alarm recording function. Select “NO” to disable pre-alarm recording function.

9. **RELAY OUT**

By selecting “1”, user can easily identify whether DVR is recording or not if relay output is connected to a signaling device. Select “NONE” if you do not wish to identify recording status.

3.4 Alarm Setup Menu

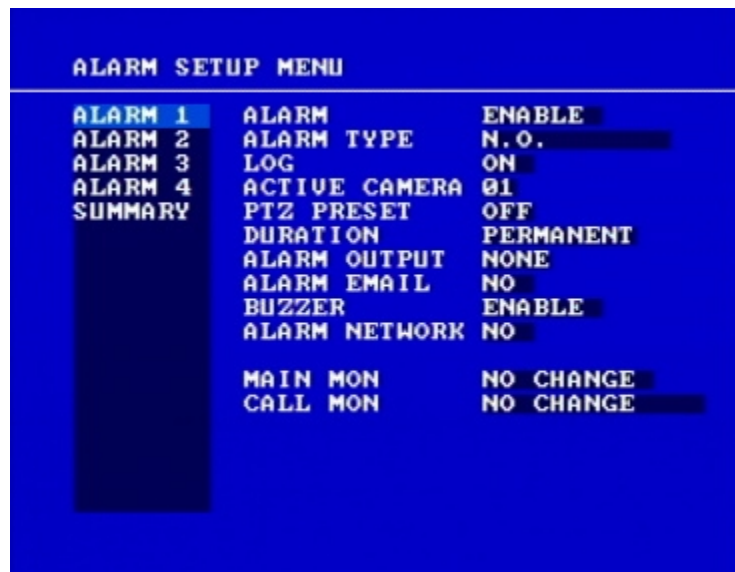

Diagram 3.7

Diagram 3.7 is a screen shot of the **ALARM SETUP MENU**. An alarm is defined as an electrical, electronic, or mechanical device that sends an alert by means of a signal. In this case the signal triggers the recorder to start recording the alarmed event. This menu contains all the alarm operations and options needed to successfully set up an alarm recording. In the **ALARM SETUP MENU** the following fields are defined as:

1. **ALARM:** This field is to turn alarm recording on or off. The Default from the factory is set to Enable. To change this, simply use the Jog Dial on the DVR.

ENABLE: Enable alarm detection.

DISABLE: Disable alarm detection.

2. **ALARM TYPE:** This field is to set the type of alarm connection. The Default from the factory is set to N.O. To change this, simply use the Jog Dial on the DVR.

N. O.: Normal Open alarm.

N. C.: Normal Close alarm.

N.O. Trans.: When the alarm is triggered, buzzer starts to function no matter how long the alarm duration is set until you set it back to N.O.

N.C. Trans.: When the alarm is triggered, buzzer starts to function no matter how long the alarm duration is set until you set it back to N.C.

3. **LOG:**

ON: Select **ON** if you wish to record Alarm Events in the Log.

OFF: Select **OFF** if you do not wish to record Alarm Events in the Log.

4. **ACTIVE CAMERA:** This field is to activate camera you want to have the alarm enabled too. For example if you had an external motion detector on camera one you would set this option to camera one. The Default from the factory is set to on. To change this, simply use the Jog Dial on the DVR.

Active camera setting, from camera 01~08. You can set the camera which corresponds to the place where the alarm is located.

Note: The recording camera number in an event depends on the alarm number, and the active camera images will not be recorded. Example: You assign camera 3 as the active camera to alarm 1. When the alarm 1 is triggered, camera 3 will be displayed and camera 1 will be recorded.

5. **PTZ PRESET:** Select **PTZ PRESET** from “001” to “255”, so that when Alarm occurs, speed dome will turn to this preset position for event recording. This function improves surveillance quality of an alarm event. If you wish to disable this function, please simply select “**OFF**”.

6. **DURATION:**

1~99 SEC: The amount of time alarm recording, screen change, buzzer and output contact will last. Adjustable from 1 ~ 99 seconds.

TRANSPARENT: Continuous recording, screen change, buzzer, and output contact for an alarm event.

7. **ALARM OUTPUT:** This will transmit a signal to another device. The setting of alarms are **NONE = not activated, 1 = output signal 1 transmitted.**

8. **ALARM EMAIL:**

YES: Send an email when an alarm occurs.

NO: Do not send an email when an alarm occurs.

The email address and e-mail server can be set in the **NETWORK SETUP MENU.**

9. **BUZZER:** Audible alarm buzzer.

ENABLE: To enable an alarm buzzer.

DISABLE: To disable an alarm buzzer.

10. **ALARM NETWORK:**

YES: Enable alarm network.

NO: Disable alarm network.

11. **MAIN MON:** Display on a main monitor when an alarm occurs.

NO CHANGE: No change on the display in the main monitor when an alarm occurs.

FULLSCREEN: A full screen of the active camera will display when an alarm occurs.

12. **CALL MON:** Display on a call monitor when an alarm occurs.

NO CHANGE: No change on the display in the main monitor when an alarm occurs.

CAMERA 1~8: Display the active camera in full screen mode to the call monitor.

13. **SUMMARY:** Dial **Jog** to change items in the **SUMMARY** table. All alarm's statuses are shown in **SUMMARY** tables. These tables are for checking alarm overall statuses, but not for changing them.

Note: Please check APPENDIX B to see other available alarm input / output functions.

3.5 Motion Setup Menu

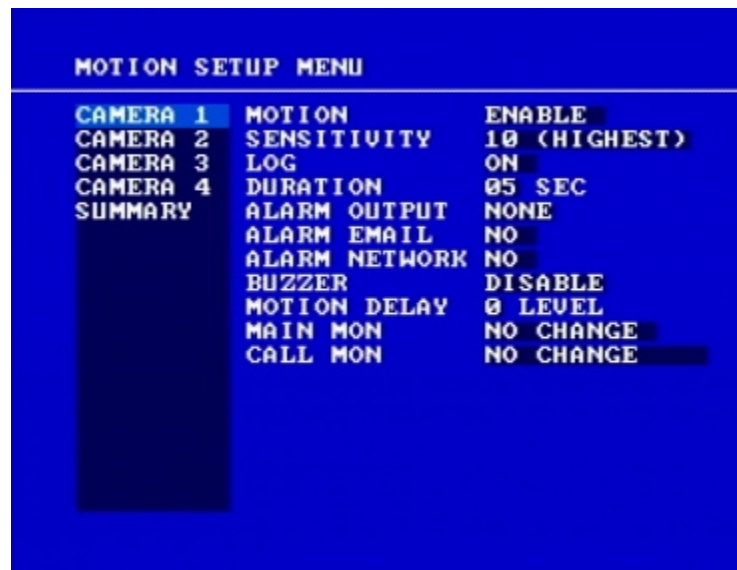

Diagram 3.8

Diagram 3.8 is a screen shot of the **MOTION SETUP MENU**. We define motion as a change of pixilation in the field of view, which is detected by the digital video recorder, and triggering the recorder to start recording. Motion is also considered an event. This menu is for setting up the digital recorder for motion recording on a per camera basis. In the **MOTION SETUP MENU** the following fields are defined as follows:

1. **MOTION:** This field is to turn motion recording on or off. The Default from the factory is set to off or disabled. To change this, simply use the Jog Dial on the DVR.

ENABLE: Enable motion detection.

DISABLE: Disable motion detection.

Note: Motion only works in live and playback modes. It is invalid while in menus.

2. **SENSITIVITY:** The sensitivity allows users to adjust to a suitable motion detection sensitivity. There are 10 sensitivities available; level 1 is the lowest, and level 10 is the highest. The default is 7. To change this, simply use the Jog Dial on the DVR.

3. **LOG:**

ON: Select **ON** if you wish to record Motion Events in the Log.

OFF: Select **OFF** if you do not wish to record Motion Events in the Log.

4. **DURATION:** The amount of time a motion event will record - from 1 sec to 99 seconds. The default value is 5 seconds. To change this, simply use the Jog Dial on the DVR.

5. **ALARM OUTPUT:** This will transmit a signal to another device. The setting of alarms are **NONE = not activated, 1 = output signal 1 transmitted.** To change this, simply use the Jog Dial on the DVR.

6. **ALARM EMAIL:**

YES: Send an email when motion occurs.
NO: Do not send an email when motion occurs.
The email address and e-mail server can be set in the **NETWORK SETUP MENU.**

7. **ALARM NETWORK:**

YES: Enable alarm network when motion occurs.
NO: Disable alarm network when motion occurs.

8. **BUZZER:** Audible buzzer when motion is detected.

ENABLE: To enable a motion buzzer.
DISABLE: To disable a motion buzzer.

9. **MOTION DELAY:**

Select motion delay time from 0~7 level.

10. **MAIN MON:** Display on a main monitor when an alarm occurs.

NO CHANGE: No change on the display in the main monitor when a motion occurs.
FULLSCREEN: A full screen of the active camera will display when motion occurs.

11. **CALL MON:** Display on a call monitor when motion occurs.

NO CHANGE: No change on the display in the main monitor when motion occurs.
CAMERA 1~8: Display the active camera in full screen mode to the call monitor.

12. **SUMMARY:** Dial Jog to scroll through options in the SUMMARY table. All alarm's statuses are shown in SUMMARY tables. These tables are for checking alarm overall statuses, but not for changing them.



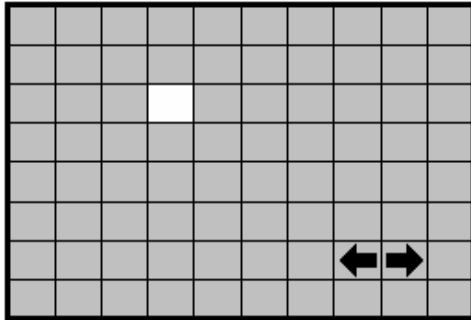

To edit a **MOTION AREA**, enter a desired channel and press **SELECT**. Motion must be set to “**Enable**” in order to edit the motion detection area.



In the motion edit mode:

The default motion area of each camera is entire screen which displays in light green.

Press **COPY** to start setting an area.

Use the **JOG** Dial to move the cursor. Press **ENTER** to switch between vertical   and horizontal   movement.

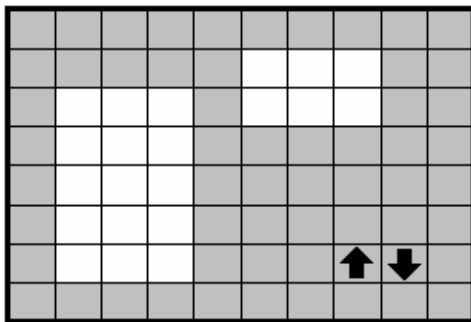

Press **SEARCH** to end and enable the selected area, or press **PAUSE** to end and disable the area.

To quit the motion area edit, press **MENU**.

- **To test a motion area:** Grids will turn into light red from light green when a motion is detected.
- **To clear the motion entire area:** Press **PLAY** to clear the entire motion area.
- **If you forget the motion grid commands:** Press **DISPLAY** to get a hint window (shows below) in motion edit mode.

MENU	- EXIT
COPY	- SELECT AREA
ENTER	- CHANGE DIR
SEARCH	- ON AREA
PAUSE	- OFF AREA

3.6 VIDEOLOSS Setup Menu

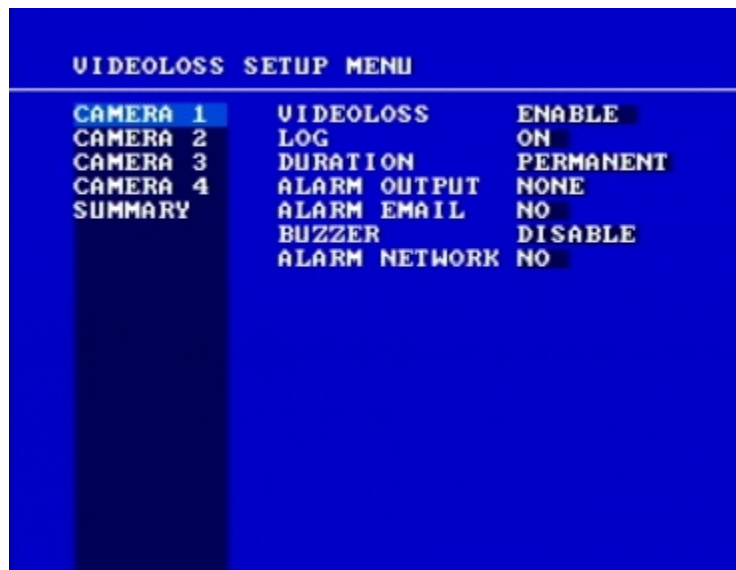

Diagram 3.9

Diagram 3.9 is a screen shot of the **VIDEOLOSS SETUP MENU**. VIDEOLOSS event is caused when no video signal input is detected on a channel. Usually it happens when the camera loses power or the camera fails. In the **VIDEOLOSS SETUP MENU** the following fields are defined as follows:

1. **VIDEOLOSS:**

ENABLE: Enable video loss detection.

DISABLE: Disable video loss detection.

2. **LOG:**

ON: Select **ON** if you wish to record Video Loss Events in the Log.

OFF: Select **OFF** if you do not wish to record Video Loss Events in the Log.

3. **DURATION:** The amount of time a Video loss event will record - from 1 sec to 99 seconds. The default value is 5 seconds. To change this, simply use the Jog Dial on the DVR.

4. **ALARM OUTPUT:** This will transmit a signal to another device. The setting of alarms are **NONE = not activated, 1 = output signal 1 transmitted**. To change this, simply use the Jog Dial on the DVR.

5. **ALARM EMAIL:** Select “**YES**” for sending an email when video loss occurs. The email address can be set in the **NETWORK SETUP MENU**.
6. **BUZZER:** Audible alarm buzzer.

ENABLE: To enable a video loss buzzer.

DISABLE: To disable a video loss buzzer.
7. **ALARM NETWORK:**

YES: Enable alarm network.

NO: Disable alarm network.
8. **SUMMARY:** All video loss’s statuses are shown in **SUMMARY** tables. These tables are for checking video loss overall statuses, but not for changing them.

3.7 Network Setup Menu



Diagram 3.10

Diagram 3.10 is a screen shot of the **NETWORK SETUP MENU**. This menu is for setting up the configurations for networking to the DVR. There are 6 subentries that are **CONFIG**, **ALARM**, **EMAIL**, **PASSWORD**, **PPPoE** and **DDNS** in the **NETWORK SETUP MENU**. Mobile units will also have the **WIRELESS** and **GPS** features available. Please refer to the Networking Chapter of this manual to fully understand how to setup your network for this DVR. In the Network Setting Menu the following fields are defined as follows:

Note: Since every Network Configuration is different, please contact your Network Administrator or ISP for details on how to assign those IP addresses and port numbers.

3.7.1 CONFIG

In the **CONFIG** of the **NETWORK SETUP MENU**, we define:

1. **IP CONFIG:**

FIXED IP: User can manually set the IP address for network connection.

DHCP: DHCP server in LAN will automatically provide the IP address for network connection. When you choose this option, the numbers will be faded out.

PPPoE: This is a DSL connection application. ISP will ask user to input user name and password. When you choose this option, please configure settings in the PPPoE options first.

2. **IP Address**

This field shows the current IP Address for the DVR. A Fixed IP address does not change and must be set manually. To change this, simply use the Jog Dial on the DVR. When DHCP is selected, DHCP server will assign this value automatically.

***Note:** The addresses in the machine are for our own testing you should apply your own addresses to comply with your network. Refer to Networking Chapter for more details.*

3. **SUBNET MASK**

This field is to set the subnet mask for your network so as the DVR will be recognized within the network. Example: 255.255.255.000. To change this, simply use the Jog Dial on the DVR. When DHCP is selected, the DHCP server will assign this value automatically.

4. **GATEWAY**

This field is to set the gateway for your network so the DVR will be recognized within the network. To change this, simply use the Jog Dial on the DVR. When DHCP is selected, the DHCP server will assign this value automatically.

5. **DNS SERVER**

This field is to set the DNS server for your network so the DVR will be recognized within the network. To change this, simply use the Jog Dial on the DVR. When DHCP is selected, the DHCP server will assign this value automatically.

6. **REMOTE RELAY CONTROL:**

YES: By selecting **YES**, system will accept remote command of relay control.

NO: By selecting **NO**, system will refuse remote command of relay control.

7. **HTTP PORT**

The default port number is 80. User can change it to different port number for HTTP/WEB communication between DVR and client PC.

8. **CONTROL PORT**

The default port number is 1600. User can change it to different port number for controlling login between DVR and client PC.

9. **DATA PORT**

The default data transmitting port number is 37260. User can change it to different port number for data transfer between DVR and client PC.

Note: If you wish to have multiple users log into the DVR, please open a range of ports on your router. For example if you want to allow 4 clients to login through the default port 37260, you should open the port range 37260-37263 on your router.

10. **BW CONTROL**

This configuration allows user to control the bandwidth of DVR.

11. **MAC ADDR**

This field is for those Internet service providers or Network administrators who require a MAC address of the network card of the DVR. This option cannot be changed.

3.7.2 ALARM NETWORK

DVR can send out Alarm message to an Alarm Server. This function is reserved to work with our Control Management System – PowerCon 4. In the **ALARM** of the **NETWORK SETUP MENU**, we define:

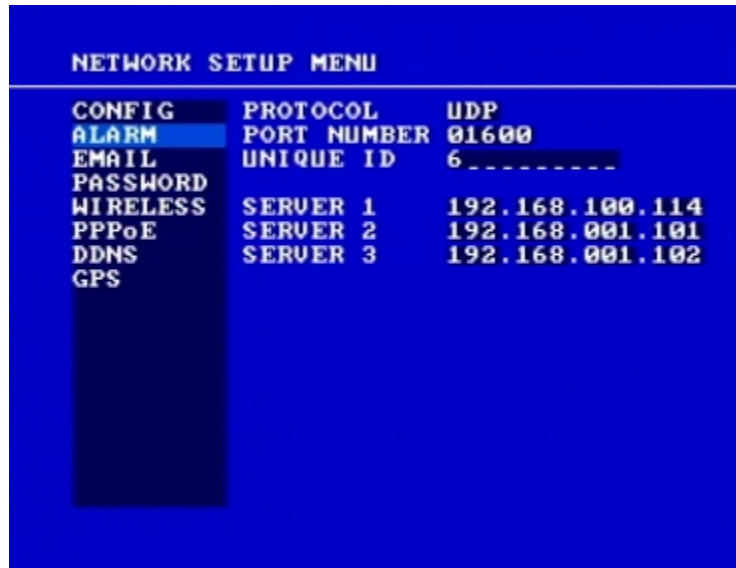

Diagram 3.11

1. **PROTOCOL:** Select which communication protocol with Alarm servers or Alarm receiving clients.

TCP: communicate with client via TCP protocol.

UDP: communicate with client via UDP protocol

2. **PORT NUMBER:** setting the communication port with Alarm server. The default is 1600.
3. **UNIQUE ID:** setting the ID number of your DVR to Alarm server.
4. **SERVER 1:** assign the IP address of Alarm server 1.
5. **SERVER 2:** assign the IP address of Alarm server 2.
6. **SERVER 3:** assign the IP address of Alarm server 3.

3.7.3 EMAIL

In the **EMAIL** of the **NETWORK SETUP MENU**, we define:

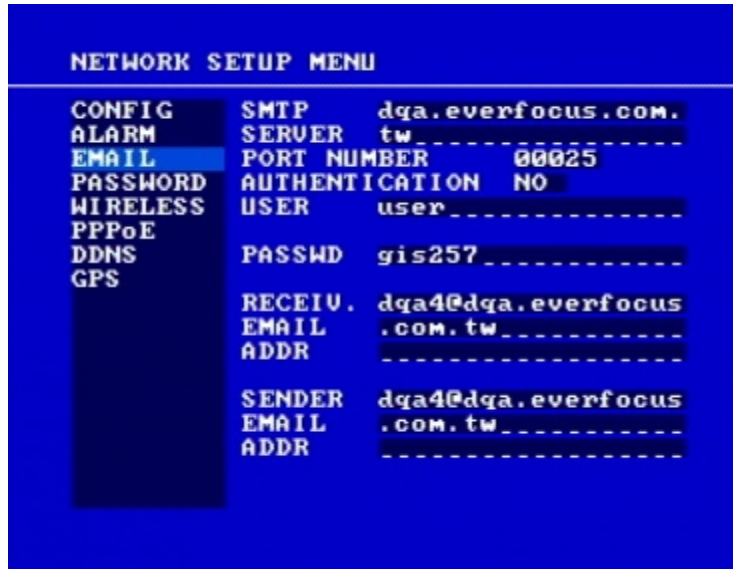

Diagram 3.12

1. **SMTP SERVER**

Assign the SMTP (e-mail) server's name.

Note: For more reliable email service, use the server's IP address.

2. **PORT NUMBER**

Assign the port number for SMTP server. The default port is 25.

3. **AUTHENTICATION**

Select "YES", if the SMTP server requires Authentication (user name / password)

4. **USER**

Input the login user ID if the SMTP server requires Authentication.

5. **PASSWD**

Input the password if the SMTP server requires Authentication.

6. **RECEIV. EMAIL ADDR**

Input the e-mail address for receiving e-mail messages when the EVENT is enabled and triggered. Example: In Motion Setup Menu, if the "EMAIL/NETWORK" is set to "YES", this e-mail address will receive a message and a still image (in "ARV" format) from the DVR when Motion is triggered. This "ARV" file can be played back by opening "DVRViewer.exe" which can be downloaded from the DVR's Network Viewer or from the Copy Menu.

7. SENDER EMAIL ADDR

Input sender's e-mail address, so that receiver can recognize the sender when an event message is sent out.

3.7.4 PASSWORD

In the **PASSWORD** of the **NETWORK SETUP MENU**, we define:



The screenshot shows a terminal window with a blue background and white text. The title is "NETWORK SETUP MENU". Below the title is a table with four columns: CONFIG, NAME, PASSWORD, and LEVEL. The "PASSWORD" row is highlighted in blue. The table contains the following data:

CONFIG	NAME	PASSWORD	LEVEL
ALARM	1 ADMIN	*****	ADMIN
EMAIL	2 USER2	*****	LIVE
PASSWORD	3 USER3	*****	LIVE
WIRELESS	4 USER4	*****	LIVE
PPPoE	5 USER5	*****	LIVE
DDNS	6 USER6	*****	LIVE
GPS			

Diagram 3.13

Name/Password/Level: This category is to set up the users that will log into the network. Please remember that this portion of the Network setting menu is set up in column format.

The default User Name = admin

The default Password = 11111111 (only numeric)

There are 3 level types:

1. **Admin:** User has all the rights including viewing live video, performing a search, playback, archiving video, controlling the PTZ camera (if one is connected), and remote configuration.
2. **Play:** User can view live video, playback, and archive, but does not have access to PTZ control or remote configuration.
3. **Live:** Allows user only to view live video.

3.7.5 WIRELESS

In the **WIRELESS** of the **NETWORK SETUP MENU**, we define:



Diagram 3.14

1. **DHCP:** Enable or disable the Dynamic Host Communication Protocol.
YES: Enable DHCP service.
NO: Disable DHCP service.
2. **IP ADDRESS:** Assign an IP address for this unit, for example: 192.168.010.200
When DHCP is YES, the DHCP server will assign this value automatically.
3. **SUBNET MASK:** Assign a subnet mask of the network for this unit, for example:
255.255.255.0. When DHCP is YES, the DHCP server will assign this value automatically.
4. **GATEWAY:** Assign a default gateway for this unit, for example: 192.168.010.001
When DHCP is YES, the DHCP server will assign this value automatically.
5. **DNS SERVER:** Assign a DNS server for this unit, for example: 168.195.001.001
When DHCP is YES, the DHCP server will assign this value automatically.
6. **MODE:** **STA** stands for Station (cannot be changed)
7. **AUTHENTICATION:**
Select from **OPEN/NONE**, **OPEN/WEP**, **SHARED/NONE**, **SHARED/WEP** or **WPAPSK/TKIP**.
Open: no need of shared key.

Shared: need shared key.

WEP: uses encrypted data transmission. Wireless networks broadcast messages using radio and are thus more susceptible to eavesdropping than wired networks.

WPAPSK: Each user must enter a passphrase to access the network.

TKIP: Randomizes the key used for each packet. The key is created by mixing together a base key, the MAC address of the transmitting station, and the serial number for the packet. The mixing operation is designed to put a minimum demand on the stations and access points, yet have enough strength so that it cannot easily be broken.

8. **AP ESSIP:** Enter the SSID of Access Point to be connected.

9. **KEY:** Password of the Access Point.

10. **NETWORK TYPE:**

Select from **INFRA** (infrastructure) and **ADHOC** for network type.

3.7.6 PPPoE

In the PPPoE of the NETWORK SETUP MENU, we define:



Diagram 3.15

1. **USER:** User name that is provided by ISP for PPPoE connection
2. **PASSWD:** Password that is provided by ISP for PPPoE connection
3. **PRIMARY DNS:** IP address of DNS server that is provided by ISP.
4. **SECONDARY DNS:** If your ISP provides a secondary DNS address, please set it here.

NOTE:

*If you change IP CONFIG to PPPoE before completing all settings in the **PPPoE** Setup Menu, then the PPPoE function will not work. Make sure you configure the PPPoE settings completely before making this change.*

3.7.7 DDNS

In **DDNS** of the **NETWORK SETUP MENU**, we define:



Diagram 3.16

1. **SERVER:** DDNS provider.
2. **USER:** User name of the account.
3. **PASSWD:** Password of the account.
4. **RECORD ID:** Record ID.
5. **FQDN:** The domain name of this account.

For example: A user had applied for a DDNS account from [Http://www.dyndns.org](http://www.dyndns.org).

User name: TEST

Password: TEST

Domain name ethne.dyndns.org.



Users can connect to DVR that uses dynamic IP address by entering the domain name “ethin.dyndns.org” in IE browser.

They don’t have to know the IP address.

***NOTE:** This domain name is only an example. The DDNS account that the user applies will differ from this example.*

EVERFOCUS DDNS

If you are using software 1.6.2 or higher, you can use the EverFocus DDNS server.

1. First, go to the website <http://everfocusddns.com> and check for an available name
2. In the DDNS Menu, choose “EverFocus DDNS” for Server
3. For Hostname, put the name you chose from the DDNS website.
4. Press the **SELECT** button to synchronize with the server. You should see the word “Success” at the bottom of the screen. If you get a message saying “Could Not Find Server”, double-check your network settings and try again.
5. You should now be able to connect by typing in the host name you created.

Example: <http://hostname.everfocusddns.com>

3.7.8 GPS

In **GPS** of the **NETWORK SETUP MENU**, we define:

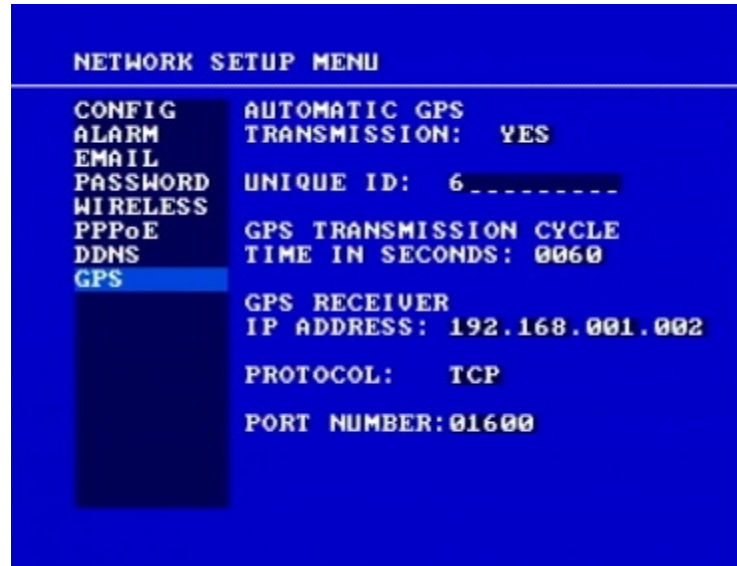

Diagram 3.17

1. **AUTOMATIC GPS**
2. **TRANSMISSION:**
YES: select YES to enable transmission
NO: select NO to disable transmission
3. **UNIQUE ID:** Input GPS Unique ID.
4. **GPS TRANSMISSION CYCLE TIME IN SECONDS:**
Enter GPS transmission cycle time in seconds.
5. **GPS RECEIVER IP ADDRESS**
Set GPS receiver's IP address.
6. **PROTOCOL:**
Select protocol from TCP and UDP.
7. **PORT NUMBER:** GPS port number.

3.8 Schedule Setup Menu

TP	DAY	START	END	SET
1	DLY	12:33	12:34	OFF
2	DLY	00:00	00:00	OFF
3	DLY	00:00	00:00	OFF
4	DLY	00:00	00:00	OFF
5	DLY	00:00	00:00	OFF
6	DLY	00:00	00:00	OFF
7	DLY	00:00	00:00	OFF
8	DLY	00:00	00:00	OFF

DLY = DAILY
WDAY = MON to FRI
WEND = SAT and SUN

Diagram 3.17

Diagram 3.17 is a screen shot of the **SCHEDULE SETUP MENU**. In this menu you can set a unique timer any day of the week to start recording from a specified start time to an end time. You will notice TP (time period) 1~8, which is also seen in the Camera Menu. In the **SCHEDULE SETUP MENU** the following fields are defined as:

1. **DAY:** This field represents the day of the week you wish to set the timer record for. It is set to DLY as default. You may choose from Mon-Sun as well as WDAY (weekday), WEND (weekend), or DLY (daily). To change this, simply use the Jog Dial on the DVR.

MON (Monday), **TUE** (Tuesday), **WED** (Wednesday), **THU** (Thursday), **FRI** (Friday), **SAT** (Saturday), **SUN** (Sunday).

WDAY: Weekday, from Monday to Friday.

WEND: Weekend, Saturday and Sunday.

DLY: Daily, everyday of the week.

2. **START:** This field is used to set the time you wish to start the timer recording. To change this, simply use the Jog Dial on the DVR.

Hour: 0 ~ 23 in 24 hour time format; 1~12 in 12 hour time format.

Minutes: 00 ~ 59

3. **END:** This field is used to set the time you wish to stop the timer recording. To change this, simply use the Jog Dial on the DVR.

Hour: 0 ~ 23 in 24 hour time format; **1~12** in 12 hour time format.

Minutes: 00 ~ 59

Note: To record all day long, use 12:00am~12:00 am for 12-hour-format or 00:00~00:00 for 24-hour-format.

4. **SET:** This field is used to turn the timer recording on or off. To change this, simply use the Jog Dial on the DVR.

ON: Enable a scheduled record time period.

OFF: Disable a scheduled record time period.

3.9 Disk Setup Menu

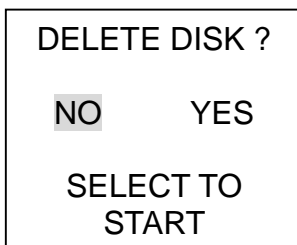

Diagram 3.18

Diagram 3.18 is a screen shot of the **DISK SETUP MENU**. This menu is for viewing Disk information and formatting the disks. For every configuration change or initial setup we recommend formatting the Hard Disk. In the **DISK SETUP MENU** the following fields are defined as follows:

1. **DISK INFORMATION:** Select disks, there are 4 disks in each table. Only one disk is available for this model.
2. **DISK VIDEO DELETE:** Press **SELECT** to start delete.

A delete disk confirmation window will show up after pressing **SELECT** button.



Dial the Jog to move highlighter to **YES**, and then press **SELECT** button; a deleting indicator **DELETE.....** will show up.

If you do not want to delete the disk after the delete disk confirmation window shows up, you can move highlighter to **NO**, and then press **SELECT** to quit.

An indicator of success **SUCCESS.....** will show up when delete is completed.

Note: System will ask you to stop recording if you delete the disk when system is in the recording mode.

2. **THERMOMETRIC SCALE:** Select **CELSIUS** or **FAHRENHEIT** for thermometric scale of the disk.
3. **NO/SIZE/C** or **F/Start/End Time:** Show the number of drives, the size of each drive, the temperature, and the range of days and times stored on the hard drive.

3.10 Control Setup Menu



Diagram 3.19

Diagram 3.19 is a screen shot of the Control Setting Menu. This menu is for setting up a connection from the digital recorder to a computer to transfer instructions or information using a keyboard or software. In the Control Setting Menu the following fields are defined as follows:

RS232:

1. **RS232 Baud Rate:** This field is to set the speed at which is used to transmit instruction or information through RS232 on the DVR. There are six different speeds, 1200 BPS, 2400 BPS, 4800 BPS, 9600 BPS, 19200 BPS, and 38400 BPS. The default setting from the factory is 9600 BPS. To change this, simply use the Jog Dial on the DVR.
2. **RS232 Stop Bit:** This field is to set the stop bit for the RS232 connection. There are two different stop bits, 1 or 2. The default in the DVR is set to 1. To change this, simply use the Jog Dial on the DVR.
3. **RS232 Parity:** This field is to select the parity level at which you will be connected. You can choose between None, Odd, or Even parity levels. Default is set to none. To change this, simply use the Jog Dial on the DVR.
4. **RS232 Data Bit:** This field is the data bit at which you will be transferring. There are two settings for this option: 8 or 7. The default is set to 8. To change this, simply use the Jog Dial on the DVR.

RS485:

5. **RS485 Baud Rate:** This field is to set the speed at which is used to transmit instruction or information through RS485 on the DVR. There are six different speeds, 2400, 4800, 9600, 19200, 38400 and 57600BPS. The default setting from the factory is 9600 BPS. To change this, simply use the Jog Dial on the DVR.
6. **RS485 Stop Bit:** This field is to set the stop bit for the RS485 connection. There are two different stop bits, 1 or 2. The default in the DVR is set to 1. To change this, simply use the Jog Dial on the DVR.
7. **RS485 Parity:** This field is to select the parity level at which you will be connected. You can choose between None, Odd, or Even parity levels. Default is set to none. To change this, simply use the Jog Dial on the DVR.
8. **RS485 Data Bit:** This field is the data bit at which you will be transferring. There are two settings for this option: 8 or 7. The default is set to 8. To change this, simply use the Jog Dial on the DVR.
9. **RS232/RS485 ID:** This entry is used to assign individual ID codes if more than one unit is used through the RS232/RS485 connection. The ID code for the DVR can be set from 001-255. The default is set to 001. To change this, simply use the Jog Dial on the DVR.
10. **PTZ PROTOCOL:** Select PTZ protocol from **EVERFOCUS**, **PELCO-D**, **PELCO-P** and **ED2200/2250**.

3.11 Warning Setup Menu

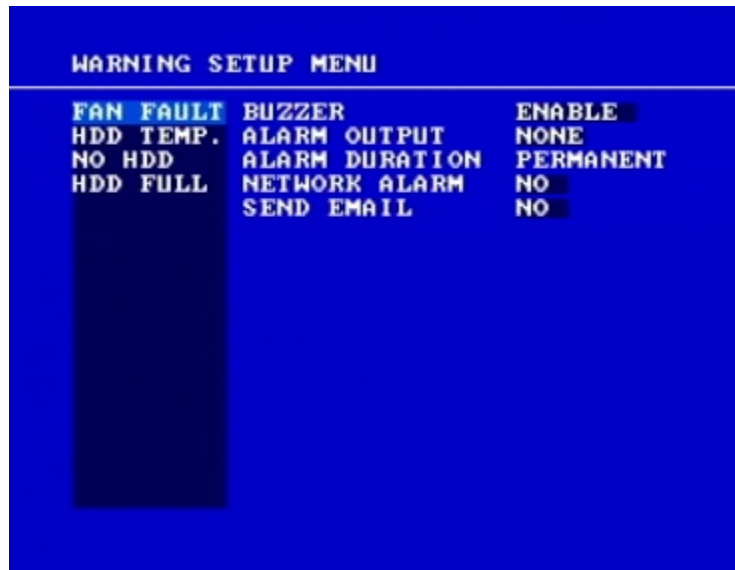

Diagram 3.20

Diagram 3.20 is a screen shot of the **Warning Setup Menu**. This menu is to set the warning system settings. If any critical errors arise, this portion of the menu is used for handling them. In the **Warning Setup Menu** the following fields are defined as:

3.11.1 FAN FAULT

In **FAN FAULT**, we define:

1. **BUZZER:** Fan buzzer. To change this, simply use the Jog Dial on the DVR.

ENABLE: To enable a buzzer when the fan does not work.

DISABLE: To disable fan buzzer.

2. **ALARM OUTPUT:** This will transmit a signal to another device. The setting of alarms are **NONE = not activated, 1 = output signal 1 transmitted**. To change this, simply use the Jog Dial on the DVR.
3. **ALARM DURATION:** Permanent, this setting cannot be changed.

4. NETWORK ALARM:

YES: To enable network alarm.

NO: To disable network alarm.

5. SEND EMAIL:

YES: Send an email when the fan does not work.

NO: Do not send an email when the fan does not work.

The email address can be set in the **NETWORK SETUP MENU**.

3.11.2 HDD TEMP

In **HDD TEMP**, we define:



Diagram 3.21

1. **BUZZER:** HDD TEMPERATURE buzzer.

ENABLE: To enable a buzzer when HDD's temperature is higher than the temperature set in "SET TEMPERATURE".

DISABLE: To disable HDD TEMP. buzzer.

2. **ALARM OUTPUT:** This will transmit a signal to another device. The setting of alarms are **NONE = not activated, 1 = output signal 1 transmitted.** To change this, simply use the Jog Dial on the DVR.

3. **ALARM DURATION:** Permanent, this setting cannot be changed.

4. **NETWORK ALARM:**

YES: To enable network alarm.

NO: To disable network alarm.

5. **SEND EMAIL:**

YES: Send an email when HDD's temperature is overheated.

NO: Will not send an email when HDD's temperature is overheated.

The email address can be set in the **NETWORK SETUP MENU.**

6. **STOP RECORD:**

YES: Stop recording when HDD's temperature is overheated.

NO: Will not stop recording even when HDD's temperature is overheated.

7. **SET TEMPERATURE:**

It is possible to set temperature. When HDD's temperature is higher than the degree you set, then all other settings in HDD TEMP. will take effect (BUZZER, ALARM OUTPUT, ALARM DURATION, NETWORK ALARM, SEND EMAIL, STOP RECORD).

3.11.3 NO HDD

In **NO HDD**, we define:



Diagram 3.22

1. **BUZZER:** NO HDD buzzer.

ENABLE: To enable a buzzer when no HDD has been found.

DISABLE: To disable NO HDD buzzer.

2. **ALARM OUTPUT:** This will transmit a signal to another device. The setting of alarms are **NONE = not activated, 1 = output signal 1 transmitted.** To change this, simply use the Jog Dial on the DVR.

3. **ALARM DURATION:** Buzzer noise and event record duration of an alarm, from 1 sec to 99 seconds or permanent. The default value is 5 seconds.

4. **NETWORK ALARM:**

YES: To enable network alarm.

NO: To disable network alarm.

5. SEND EMAIL:

YES: Send an email when no HDD has been found.

NO: Will not send an email when no HDD has been found.

The email address can be set in the **NETWORK SETUP MENU**.

3.11.4 HDD FULL

In **HDD FULL**, we define:

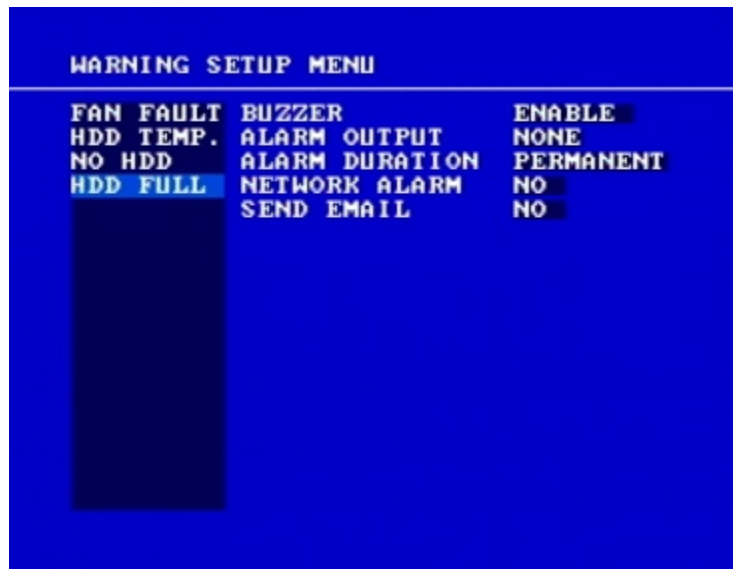

Diagram 3.23

1. **BUZZER:** HDD FULL buzzer.

ENABLE: To enable a buzzer when HDD is full.

DISABLE: To disable HDD Full buzzer.

2. **ALARM OUTPUT:** This will transmit a signal to another device. The setting of alarms are **NONE = not activated, 1 = output signal 1 transmitted**. To change this, simply use the Jog Dial on the DVR.

3. **ALARM DURATION:** Buzzer noise and event record duration of an alarm, from 1 sec to 99 seconds or permanent. The default value is 5 seconds.

4. **NETWORK ALARM:**

YES: To enable network alarm.

NO: To disable network alarm.

5. **SEND EMAIL:**

YES: Send an email when HDD is full.

NO: Will not send an email when HDD is full.

The email address can be set in the **NETWORK SETUP MENU**.

3.12 System Setup Menu



Diagram 3.24

Diagram 3.24 is a screen shot of the **SYSTEM SETUP MENU**. This menu is for setting up any additional options and restoring defaults to the digital recorder. In the **SYSTEM SETUP MENU** the following fields are defined as follows:

1. **SYSTEM VERSION:** Current system firmware version.
2. **SYSTEM VIDEO FORMAT:** NTSC or PAL. System can detect the input signal type automatically from camera 1 while system is booting up. Users do not need to set it up.

Note: Camera 1 input must be connected in order to auto-detect video format.

3. **LOAD/SAVE CONFIGURATION:**

YES: Turn the jog to enter the selection window, there are 4 options available: **CANCEL**, **DEFAULT**, **LOAD**, and **SAVE**. Select “CANCEL” to exit the window. Select “DEFAULT” to load factory default values. Select “LOAD” to upload DVR configuration settings from USB. Select “SAVE” to save existing DVR configuration settings to USB device. Press “**SELECT**” button from the front panel to confirm once the selection is made. Note that a USB device has to be inserted properly before choosing “LOAD” or “SAVE” options. System will ask you to stop recording before you can load defaults, load saved settings, or save existing settings.

NO: Press “**ENTER**” to move past “LOAD/SAVE CONFIGURATION”.

4. **UPDATE SYSTEM SOFTWARE:** Turn the jog to enter the selection window.

YES: Select **YES** to update system software from USB and press **SELECT** to start.

NO: Select **NO** and press **SELECT** to cancel update.

Note:

- System will ask you to stop recording before you can update the system.

- USB device must be inserted properly before updating system software.

- Do not remove USB device when you are updating system software as this can cause the machine to crash.

- Power failure or machine being turned off during updating process may result an abnormal start up of the machine.

- After upgrading system software, please do the following actions before recording:

1) Load System Default in **System Setup Menu**.

2) Delete disk in **Disk Setup Menu**.

5. **LANGUAGE:** System language can be set in different languages. The available languages depend on the country or area. Subject to change without further notice. Please consult your sales representative for the most up to date information.

6. **QUICK PLAY:** Allows the user to press the play button and playback video from the time indicated from this field (0 ~ 59 Min).

ON: Enable quick play. Videos will begin playing back from the indicated time previous to current recording.

OFF: Disable quick play. Videos will begin playing back from the end point of the last playback.

TIME: Quick play time, from 1 ~ 59 min. The default value is 10 minutes.

Note: The minimum recommended quick play time is 10 minutes. If you set a quick play time less than this, the video may not be played because it is still in HDD temporary storage.

7. **SYSTEM PASSWORD ENABLE:**

YES: Select **YES** to enable the password function.

NO: Select **NO** to disable the password function.

8. **PASSWORD and RIGHTS:** The login passwords in this menu are used to operate and set up the machine locally, not from the remote TCP/IP connection. The different passwords indicate the different level of users, and no login name is necessary. The digit will appear instead of a “*” sign when the cursor is moved on it. Press **ENTER** to go to next digit, **DISPLAY** to go to the previous digit, and turn the Jog Dial to change the highlighted digit. The available digits are **1, 2, 3, and 4** (also **5, 6, 7, and 8** in 8 channel version).

There are three system access levels and the default “none” access level. The following chart shows the rights of each level.

User Level and Right				
LEVEL	LEVEL-3	LEVEL-2	LEVEL-1	NONE ACCESS
RIGHT	ADMINISTRATOR	OPERATOR	GENERAL	---
DISPLAY	OK	OK	OK	OK
MODE	OK	OK	OK	OK
ZOOM	OK	OK	OK	OK
SELECT	OK	OK	OK	NO
SEQ	OK	OK	OK	NO
CALL	OK	OK	OK	NO
MENU	OK	NO	NO	NO
COPY	OK	OK	NO	NO
SEARCH	OK	OK	NO	NO
PLAY	OK	OK	NO	NO
STOP	OK	OK	NO	NO
REC	OK	OK	NO	NO
PAUSE	OK	OK	NO	NO
ALARM RESET	OK	OK	NO	NO

Note:

1. If the passwords of different levels are set the same, you will enter a higher level when you login. For example, you will login to ADMINISTRATOR level if the password of ADMINISTRATOR and GENERAL levels are the same.
2. After exiting to the live camera view and waiting 60 seconds, the system will automatically log out to the None Access level.

4. Recording Overview

Before continuing with the Recording Overview please be sure to have reviewed DVR Menu Setup (Chapter 3), specifically the Camera & Schedule Menus. You are now ready to begin setting up the machine for recording. This chapter will show you how to setup the recorder for three basic types of recording: Instant recording, scheduled recording, and event recording. **Instant recording (N)** is simple; just press the Record button to start recording, much like pressing the record button on a VCR. **Scheduled recording (1~8)** is based upon a set time period of when to begin & end the recording. **Event recording** consists of an alarm, motion, or video loss triggering the DVR to record that event.

4.1 Instant (N) Recording Setup

Press the Record key to start recording immediately.



REC

When **REC** is pressed, the pictures being monitored will be recorded in the HDD.

The recording quality and recording speed can be set in the **CAMERA SETUP MENU**. To set the target camera for a particular recording speed (IPS) when using the instant record method, apply the changes to the last Time Period (TP) row labeled **N**.

A “R##” sign appears in the record status bar. The number following R signifies which HDD is being recorded to.



STOP

Press **STOP** key to stop instant recording.

The **STOP** key can only be used for instant recording mode. Schedule or event recording mode must be turned off in their respective menus.

When the HDD is full, the machine will stop recording automatically or overwrite from the beginning of the HDD, depending on the setting in the **RECORD SETUP MENU**.

Note:

1. In order to start or stop Instant Recording, you must exit completely from all menus.
2. If **STOP** is pressed while machine is recording and playing video, the playing function will be disabled first. If **STOP** is pressed twice the DVR will come out of record mode completely.
3. We suggest not to remove the Hot-Swappable Drive while the machine is recording or in playback. Please stop any type of recording or playback first before removing the Hot-Swappable Drive.

4.2 Schedule Recording Setup

Set up the **DAY**, **START** time, **END** time and then turn **SET** to ON in the **SCHEDULE SETUP MENU** in order to start Schedule Recording.

TP	DAY	START	END	SET
1	DLY	12:33	12:34	OFF
2	DLY	00:00	00:00	OFF
3	DLY	00:00	00:00	OFF
4	DLY	00:00	00:00	OFF
5	DLY	00:00	00:00	OFF
6	DLY	00:00	00:00	OFF
7	DLY	00:00	00:00	OFF
8	DLY	00:00	00:00	OFF

DLY = DAILY
WDAY = MON to FRI
WEND = SAT and SUN

Diagram 4.1

Please refer to **SCHEDULE SETUP MENU** to see setting procedure and more details.

4.3 Event Recording Setup

We will define two event recording types **ALARM** and **MOTION**. After the event recording is enabled, the DVR will start an event recording when an event occurs. For instance when motion activity is detected by the DVR it will begin recording at the specific IPS set under event column. Or when an alarm is detected by the DVR it will begin recording at the specific IPS set under event column.

In order to start an event recording, you will **NEED** to perform the following:

1. Enable the event in each setting (Alarm or Motion Menu) first. For example, enable Camera 1 in the **MOTION SETUP MENU** (as shown below). You can enable multiple alarm or motion triggers.

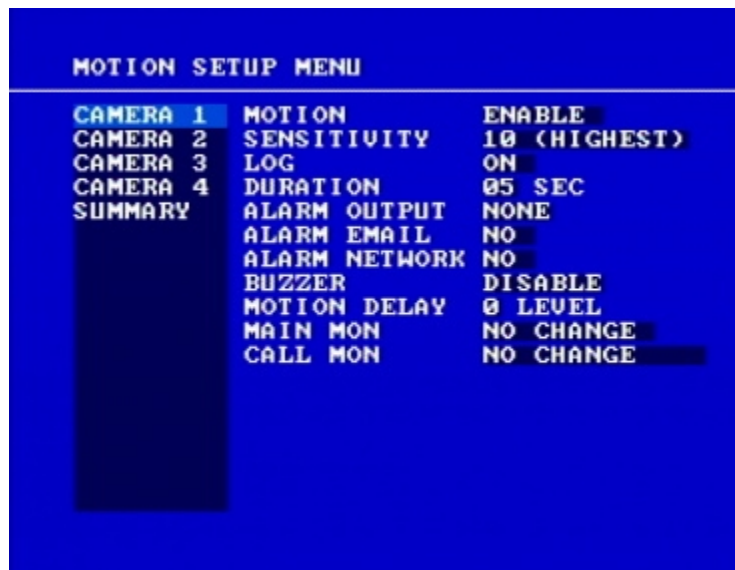

Diagram 4.2

- When the event is set, enter the **CAMERA SETUP MENU** to set the event recording speed (IPS) of the camera for TP N (Instant Recording) or TP 1~8 (Schedule Recording).

The screenshot shows the 'CAMERA SETUP MENU' with the following configuration:

CAMERA	TITLE	CH01
CAMERA 1	PTZ ID	011
CAMERA 3	INSTALL/COVERT	ON /OFF
CAMERA 4	SEQ(MAIN/CALL)	03/03 SECS
SUMMARY	REC QUALITY	SUPERIOR

TP	REC SPEED	ACTION
1	6 IPS	15 IPS ON
2	6 IPS	15 IPS ON
3	6 IPS	15 IPS ON
4	6 IPS	15 IPS ON
5	6 IPS	15 IPS ON
6	6 IPS	15 IPS ON
7	6 IPS	15 IPS ON
8	6 IPS	15 IPS ON
N*	0 IPS	15 IPS ON

Diagram 4.3

- Once the event and record and speed are set, you need to activate **Instant Recording** or set a time period in the **SCHEDULE SETUP MENU**. Refer to the previous sections for details on setting up these configurations.

The screenshot shows the 'SCHEDULE SETUP MENU' with the following configuration:

TP	DAY	START	END	SET
1	DLY	12:33	12:34	OFF
2	DLY	00:00	00:00	OFF
3	DLY	00:00	00:00	OFF
4	DLY	00:00	00:00	OFF
5	DLY	00:00	00:00	OFF
6	DLY	00:00	00:00	OFF
7	DLY	00:00	00:00	OFF
8	DLY	00:00	00:00	OFF

DLY = DAILY
 WDAY = MON to FRI
 WEND = SAT and SUN

Diagram 4.4

Note:

1. If you only want to record event (motion or alarm) activity **ONLY**, set the normal record speed as 0 IPS in the **CAMERA SETUP MENU**.
2. If the recording speed is changed while the machine is recording, the new recording speed will not take effect until recording is completely stopped and then reactivated.

DVR provides a record function which is triggered by external signal via the 19th pin of the **ALARM INPUT / OUTPUT** port. When the record input signal is triggered constantly, DVR will start to record according to the speeds set on Time Period (TP) N. The system will stop recording when the record input signal is no longer triggered.

Note: Please check APPENDIX B to see other available alarm input/output details.

5. Playback Overview

Before continuing please be sure to have reviewed DVR Menu Setup (Chapter 3). This chapter will show you how to setup the recorder for playback.

5.1 Basic Playback

(1) Playback



PLAY

Press the **PLAY** key to start playing back the stored image/audio. The video start time depends on the quick play setting in the **SYSTEM SETUP MENU**. The DVR is duplex, which means you can record and playback the same time.



REV.PLAY

Press the **REV. PLAY** key and the DVR will rewind while displaying video in reverse.

(2) STOP



STOP

Press the **STOP** key to stop playing back.

(3) Fast Forward/Reverse Playback



PLAY

While in playback, turn the **Shuttle** dial clockwise to begin fast forward playback.

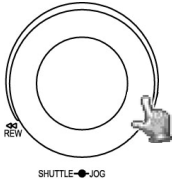

Turn the **Shuttle** dial counterclockwise to begin fast reverse playback.

The speed will be shown on the status bar of the bottom screen.

The available speeds are **2, 4, 6, 8, 16, 32, and 600**. You can either manually hold the shuttle dial in the position or press **ENTER** while holding the dial to lock the speed that is desired.

Press **PLAY** again to return normal play speed.

(4) Slow Forward/Reverse Playback



PAUSE

During playback mode, press **PAUSE** key to freeze the playing back picture.

Turn the **Shuttle** dial clockwise to begin slow forward playback.

Turn the **Shuttle** dial counterclockwise to begin slow reverse playback.

The speed will show on the status bar of the bottom screen.

The available speeds are **1/2, 1/4, 1/8, 1/16, and 1/32**. You can either manually hold the shuttle dial in the position or press **ENTER** while holding the dial to lock the speed that is desired.

(5) Image advance Forward/Reverse



PAUSE

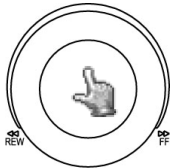

SHUTTLE-JOG

Press **PAUSE** key to freeze the picture.

Turn the **Jog** dial clockwise to advance the still video image by image.

Turn the **Jog** dial counterclockwise to rewind the still video image by image.

The field feed speed will increase if the **Jog** dial is turned quickly.

5.2 Search Playback



Press the **SEARCH** key to enter the **SEARCH MENU**.

In the **SEARCH MENU**,

Press the **ENTER** key to go to the next subentry.

Press the **DISPLAY** key to go to the previous subentry.

Dial the **Jog** clockwise or counterclockwise to change subentry values.

Press **MENU** key to exit.

Press **SELECT** key to start search.



Diagram 5.1

(1) TIME / DATE Search Playback

A **SEARCH MENU** will show up after pressing **SEARCH** key. Select “**BY TIME / DATE**”, and then select the start date/time you want to search. Then, select the camera number and Disk Number to be searched. Lastly, press **SELECT** to start search.

Note:

If there is no video stored in the date/time specified, then the image will show the end of the last play, and the display time on the status bar will show “**?:??**”.

(2) EVENT Search Playback

To search by “EVENT”, select “**BY EVENT**” for Method. Set the Start and End Date/Time limits for the events to be searched. Only events within the selected Date and Time will be displayed

7 filters (**ALARM, MOTION, VLOSS, A/M, A/V, M/V** and **A/M/V**) can be selected.

The indications of events show as below.

EVENT	Indication
ALARM	Search ALARM events
MOTION	Search MOTION events
VLOSS	Search video loss events
A / M	Search ALARM and MOTION events
A / V	Search ALARM and video loss events
M / V	Search MOTION and video loss events
A / M / V	Search all events (ALARM, MOTION and video loss)

Then select Camera number and Disk number for the events to be searched.

Lastly, press **SELECT** to start search.

- (3) The search list shows up when **SELECT** is pressed. There are 16 events in one page, and “current page / total pages” shows in the top-right corner. Dial **Shuttle** clockwise or press **COPY** to move to the next page; dial **Shuttle** counterclockwise or press **CALL** to move to the previous page. If you would like to jump to a specific page directly, you can press **Search**, then dial **Jog** to the page, and press **Enter**. Dial the **Jog** to scroll through events on the list. When the desired item is highlighted, press **ENTER** to play the selected event.

The event types and number show on the second column of the search list.

SEARCH LIST OF DISK 01 P. 001/002			
00001	RU1	01-07-2008	09:51:23
00002	TN	01-07-2008	09:52:10
00003	U02	01-07-2008	14:48:29
00004	TN	01-07-2008	14:50:56
00005	TN	01-07-2008	14:51:21
00006	TN	01-07-2008	14:52:16
00007	TN	01-07-2008	14:54:34
00008	TN	01-07-2008	14:54:41
00009	RU1	01-07-2008	14:55:38
00010	TN	01-07-2008	14:56:29
00011	RU1	01-07-2008	14:56:45
00012	TN	01-08-2008	10:14:23
00013	RU1	01-08-2008	10:21:16
00014	TN	01-09-2008	08:52:25
00015	U01	01-09-2008	08:52:32
00016	TN	01-09-2008	08:53:25

An: an Alarm event, n = input number

Dn: HDD overheated, overheat temperature is based on HDD temperature set in Warning Setup Menu. n = disk number

Fn: Fan fail, n = 1~3 fan number.

LH: (Logical Head): Earliest recorded date & time right on HDD.

LUn: Local User login, n = access level; where 1 is Administrator, 2 is Operator and 3 is General.

Mn: a Motion event. n = channel number.

PH: (Physical Head): beginning point of HDD's physical space.

PL: a Power Loss event.

RTn: a power Return event in a schedule recording mode, n = TP 1~8.

RTN: a power ReTurn event in Normal/instant recording mode.

RUn: Remote User login (using Internet Explorer), n = 1~6, user number.

Tn: a schedule Time period recording event, n = Time Period 1~8.

TN: a Normal/instant Time recording event.

Vn: a Video loss event. n = channel number.

DLB: Begin Daylight saving time.

DLE: End Daylight saving time.

The last two columns are the date and time of event.

6. Copying Video

Before continuing please be sure to have reviewed the preceding chapters. You are now ready to copy an image or video from the DVR. This chapter will show you how to copy a still image or movie from the recorder.

Insert the USB pocket driver into the USB slot on the front panel of the DVR to copy.

USB slot:

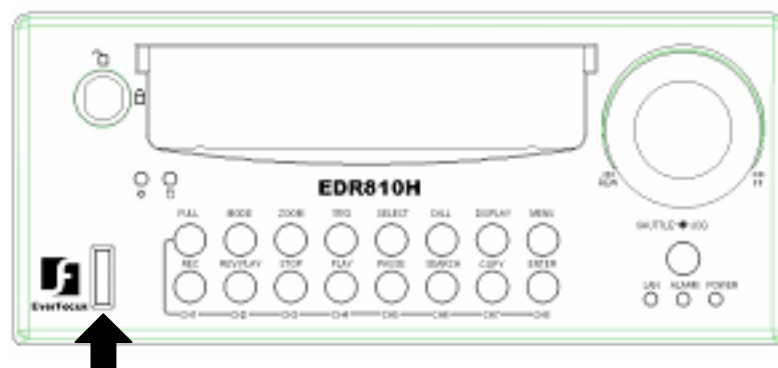

Digital Video Recorder allows users to select the camera for copying image (video) to movie file or copying EDR Viewer, which is the video player. The camera title will be displaying at the top of the screen.



COPY

Press **COPY** key and then the copy menu appears.



Diagram 6.1

In the **COPY MENU**, we define:

1. **COPY:** Select **Image** for copying images (video) to movie file.
Select **Viewer** for copying EDR Viewer player.
2. **DISK NO:** Disk number. It is fixed as “01” in this series.
3. **CAMERA NO:** Camera channel number. You can select the video of camera you would like to copy.
4. **START DATE & TIME:** The start time of video you want to copy.
END DATE & TIME: The end time of video you want to copy.
5. **SIZE OF SELECTED IMAGE:** __ MB (PRESS PLAY TO ESTIMATE)

The system can estimate the file size of the selected image you wish to copy. Simply press **PLAY** key after you have selected start date/time and end date/time. If file size is large, estimate time may take a while.

6. **DEVICE**

The media you want to store the file to. It is fixed as “USB” in this series.

After choosing copy settings, press **SELECT** to begin copy.

a. If a file size exceeds 2GB, the DVR will automatically split it into smaller video clips that will be copied individually. The current segment and completion percentage are displayed at the bottom of the screen.

b. While in playback, pressing **COPY** button will set a start and end time in the Copy Menu for span of 1 minute. (For example, Start copy point is 10-10-2005 10:00:00 and end copy point will be 10-10-2005 10:01:00) You can change either value to suit your needs.

6.1 Viewing a Copied File

1. In order to view video copied from the DVR, you will also need to download the DVR Viewer file. Insert a USB pocket drive into the DVR. Press **COPY** button to enter the Copy Menu. In the Copy Menu choose “Viewer” at the top of the screen. Then press **SELECT** button to copy the viewer to the USB.
2. When you see “Success” at the bottom of the screen, remove the USB and insert it into your computer.
3. Go to My Computer in Windows and open the Removable Drive. You will see the files you archived as well as the DVR Viewer you just downloaded.
4. Open the DVRViewer.exe and click on “Load File.”
5. Choose from one of the archived video files (.arv) that you copied from the DVR and click Open.
6. The video will begin playing back. To save it as a Windows compatible video file, click on “Save to Avi...”, choose the location you want to save it in, and click Save.

7. Call Overview

This chapter will give you basic details on how to setup the **CALL MENU** on the DVR. Press the **CALL** key and the **CALL MENU** will pop up as below.



Diagram 7.1

In **CALL MENU**, you can change the following settings for the call monitor:

1. **SEQ:** Sequence display on the call monitor. Press **SEQ** key to switch the sequence status “ON” or “OFF”.
2. **OSD:** Channel name display on the call monitor. Press **DISPLAY** key to switch the **OSD** status “ON” or “OFF”.
3. **CAMERA:** The current display camera in the call monitor. Press **Channel NO** to set display camera.
4. **QUAD DISPLAY**
 YES (CAMERA: 01~04): select YES to enable quad display of call monitor. For 8 CH model DVR, press CH 2 button to show camera 05~08 in quad display.
 NO: Select NO to disable quad display of call monitor.

8. Screen Display Setting & Mode

In a full screen display, press **SELECT** key to pop up the display adjustment window as below:

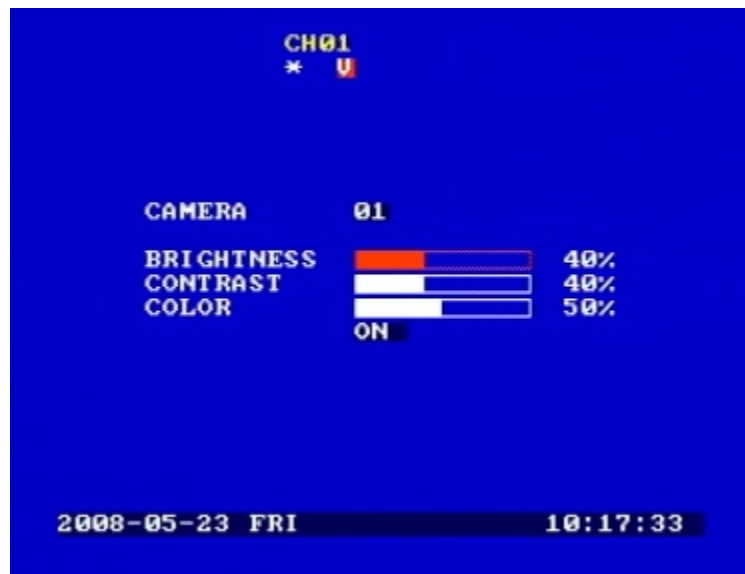

Diagram 8.1

In the screen display setting menu, we define:

1. **CAMERA:** The current camera.
2. **BRIGHTNESS:** The bright percentage of the current camera; from 0% to 100%.
3. **CONTRAST:** The contrast percentage of the current camera; from 0% to 100%.
4. **COLOR:** The color percentage of the current camera; from 0% to 100%.
5. **SHARPNESS:**

By turning SHARPNESS **ON**, the image will become sharper and clearer in live mode. This option is recommended for indoor use.

When turning SHARPNESS **OFF**, the image becomes slightly blurred in an indoor environment. However, this option is suitable for outdoor use. If image flickers under a bright, outdoor environment, then the image can become mild by turning SHARPNESS **OFF**.

The selected item will show in red color bar. Use **Jog** to increase or decrease the value. Press **ENTER** to confirm the setting value and move to next item. After finished setting, press **SELECT** or **MENU** key to save and exit the dialog.

8.1 Mode Button

Press **MODE** to switch 4, 7, 9 and PIP (picture in picture) displays for Live and Playback mode.

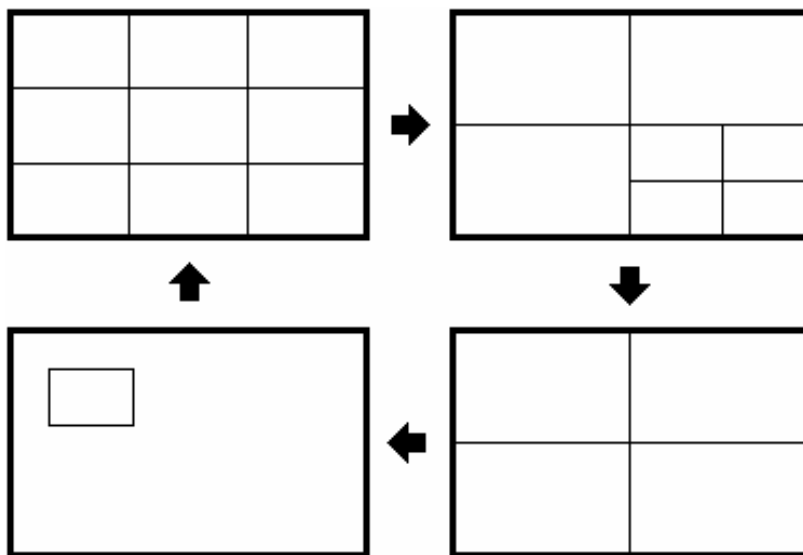

9. Upgrade Firmware

This chapter will give you basic instructions on how to upgrade the DVR's software. This will be a helpful in completing the upgrading process.

- Go to http://www.everfocus.com/support_bulletins.asp and find the DVR you have. Click on the link to save the upgrade file to your computer.
- Copy the .ETW to your USB memory stick from your computer
- Insert the USB in to the USB slot on the front panel of the DVR. When inserting the USB, make sure the direction of insertion is correct.
- Stop all recording on the DVR.
- If record does not stop when you press the stop button, this usually means you have the DVR in Schedule record. Log into the DVR menu by pressing the Menu button. Go to Schedule Setting Menu and turn all schedules OFF.
- Press the Menu button and use the Jog Dial to go to "System" menu.
- Press the Enter button to highlight "System Upgrade". Turn NO to YES using the Jog wheel.
- Highlight "YES" again and press "Select".
- You will see a message at the bottom of the screen that says "Updating, Phase 1/3". Eventually this will change to "Phase 2/3" and then "Phase 3/3". When it finishes, it will say "Success, Please Reboot".
- Once you have read "Success", press the Menu button until you log out of the menu completely. Then turn the power off on the DVR and turn it back on to reboot.

10. Networking Overview

This chapter will try to give you a detailed instruction on how to network the DVR. Before we begin the process of networking your digital recorder we should have a working knowledge of what a network is and how it works. This will be a helpful in completing the networking process.

10.1 Introduction to TCP/IP

TCP/IP is the suite of protocols used by the Internet and most LANs (Local Area Networks) throughout the world. In TCP/IP, every host (computer or other communications device) that is connected to the network has a unique IP address. By doing this you are giving your device a unique address similar to the address of your house. An IP address is composed of four octets (numbers in the range of 0 to 255) separated by decimal points. The IP address is used to uniquely identify a host or computer on the LAN. For example, a computer with the hostname Workstation could have an IP address of 192.168.1.127.

You should avoid giving two or more computers the same IP address by using the range of IP addresses that are reserved for private, local area networks; this range of IP addresses usually begins with the octets 192.168. The first three octets of an IP address should be the same for all computers in the local area network. For example, if a total of 253 computers exist in a single LAN, the IP addresses could be assigned starting with 192.168.1. x , where x represents a number in the range of 2 to 254.

10.2 Subnet Masks

Each host in a LAN has a subnet mask. The *subnet mask* is an octet that uses the number 255 to represent the network address portion of the IP address and a zero to identify the host portion of the address. For example, the subnet mask 255.255.255.0 is used by each host to determine which LAN or class it belongs to. The zero at the end of the subnet mask represents a unique host within that network. Basically the subnet mask represents the city you live in for your home address, but in this case you are stating the network you belong too.

10.3 Gateway Address

Each host in a LAN has a gateway. A gateway address is composed of four octets (numbers in the range of 0 to 255) separated by decimal points. The gateway address is used to uniquely identify a host or computer on the LAN which assigns the IP addresses to your network. For example, a Linksys router has an IP address of 192.168.1.1. If you were using this type of router within your LAN, then your gateway would be the IP address of the Linksys router. The reason this would be your gateway is because the Linksys is assigning the IP addresses for your network therefore the Linksys would be the gateway to your network. This is similar to the zip code of your address.

10.4 Virtual Ports

A **port number** represents an endpoint or "channel" for network communications. Port numbers allow different applications on the same computer to utilize network resources without interfering with each other. Port numbers most commonly appear in network programming, particularly socket programming. Sometimes, though, port numbers are made visible to the casual user. For example, some Web sites a person visits on the Internet use a URL like the following:

`http://www.everfocus.com:8100/`

In this example, the number 8100 refers to the port number used by the Web browser to connect to the Web server. Normally, a Web site uses port number 80 and this number need not be included with the URL (although it can be). In IP networking, port numbers can theoretically range from 0 to 65535. Most popular network applications, though, use port numbers at the low end of the range (such as 80 for HTTP). This could be similar to the front door of your house. Without the door to the house being open you could not enter it. This is the same case with ports on a network. If the ports for a specific IP address are not open then you could not gain access to that IP address or what it is addressing.

Note: The term port also refers to several other aspects of network technology. A port can refer to a physical connection point for peripheral devices such as serial, parallel, and USB ports. The term port also refers to certain Ethernet connection points, such as those on a hub, switch, or router.

10.5 Pre-Installation

Before we begin with the installation we must ask ourselves a few questions in order to figure out where to begin with networking our DVR's.

Do you have Hi-speed Internet? _____

There are many types of high speed Internet available. Three commonly used ones are T1, Cable, and DSL (in order of speed).

- ***Note: Everfocus suggests having a minimum upload speed of 256KBps. This can be addressed by the Internet Service Provider.***

Who is your Internet provider? _____

- Please confirm that your internet service provider that our upload speed is at least 256KBps.

What type of modem/router do you have? _____
Modem/router model name/ #

The modem/router was either installed by your Internet service provider or purchased by you to establish a connection to the Internet. A router is installed to allow multiple computers to access the Internet through the same external IP address. It in turn assigns different internal IP addresses to local computers for this specific purpose.

Do you have a static IP address? _____

A Static IP address means you use the same IP address every time you log on to the Internet. With a static IP address, other Internet users always know the identity of your computer and can easily connect with it. That way, you can host a website, email server, or other type of server connection. Everfocus suggest using a static IP address. If your Internet provider does not offer a static IP address you have the option to use a dynamic IP address. This will be explained in more detail later on in the chapter.

Do you have a dynamic IP address? _____

A Dynamic IP address means your IP address changes each time you make a connection to the Internet. We recommend asking your Internet service provider for a Static IP address. If this is not a possibility, you may purchase a router (we suggest a Linksys or D-link router) which supports DDNS. DDNS is a Dynamic Domain Name Server, a service that provides a central (public) database where DNS information can be stored and retrieved. It allows those using a dynamic IP address to be registered centrally so users can connect to it by name.

What type of DVR are you installing? _____

Everfocus EDR series: EDR 410, 810, 920, 1620, 1640, or 1680

Everfocus EDSR series: EDSR 110, 400H, 400M, 400, 900, or 1600

10.6 What Type of Network Connection do you have?

Everfocus DVR's can operate using three distinct types of networking connections.

1. **Simple One to One Connection:** A simple one to one connection is the most simple network connection. Basically it is a connection between a Computer and Another Computer or in this case a DVR using a cross-over cable.
2. **Direct High Speed Modem Connection:** A direct high speed modem connection is a network connection from the modem directly to a computer or in this case the DVR.
3. **Router or LAN Connection –** A local area network connection either requires a router or a pre-existing LAN connection. Typically this type of connection is the most commonly used application. A router allows multiple computers and DVR's to access each other as well as the Internet. It assigns different internal IP addresses to the computers.

10.7 Simple One to One Connection

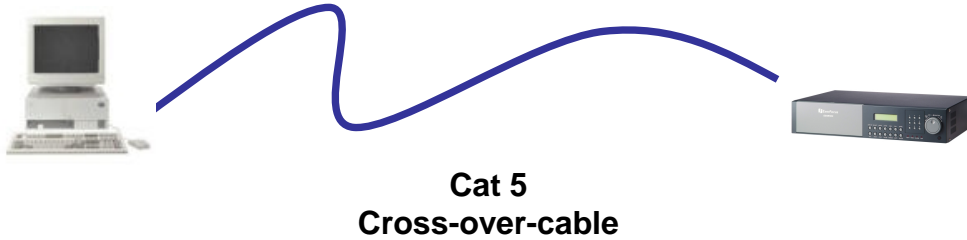

Crossover Ethernet Cable Pin outs:

The Diagram below shows the pin configurations for a cross over cable.

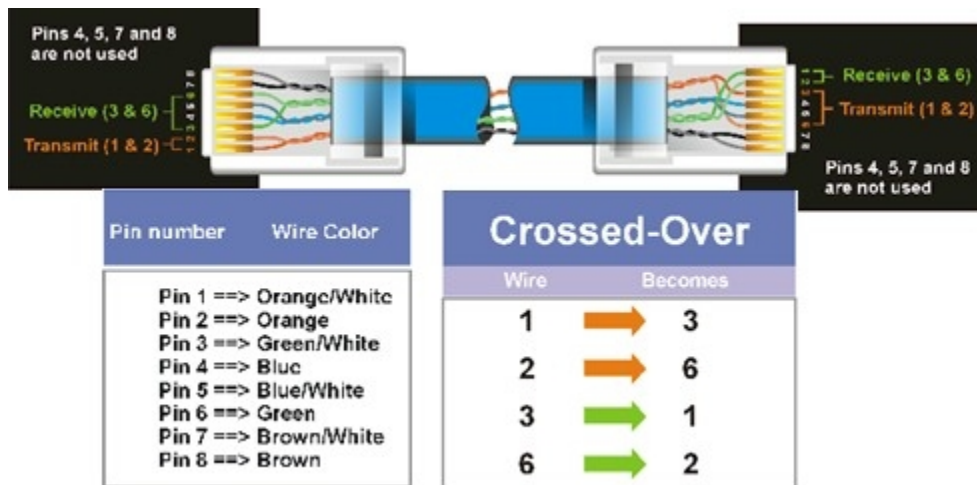
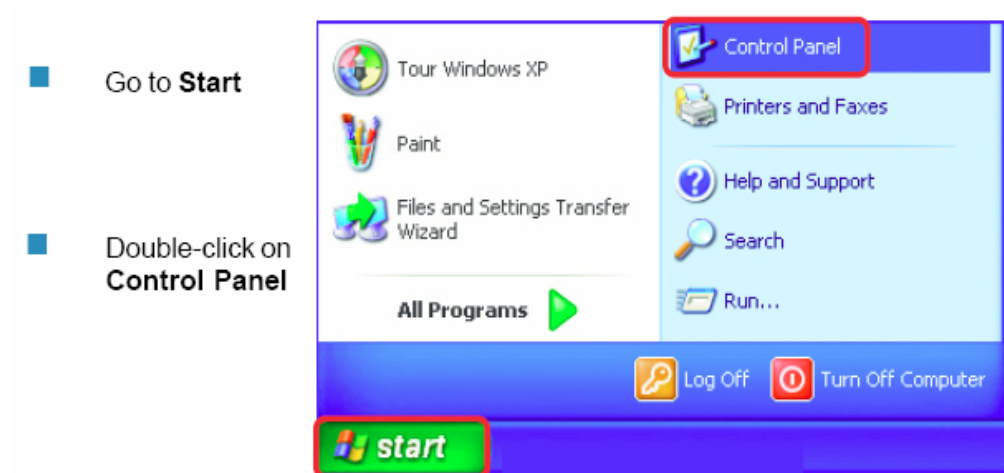

Diagram 10.1

Connection Procedure:

- The First step is to purchase or make a cross over cable. We recommend purchasing one if you have never made a cross over cable. Please remember you can not use a straight through network cable for this application
- Once you have a cross over cable plug one end into the LAN port on the back of the recorder and the other into the network card on the back of the computer.
- Now Log into the Everfocus DVR menu and using the jog dial from the previous chapter go to the Network Setting Menu. (Please see **Network Setting Menu** for more instructions)
- Assign an IP address of 192.168.001.003 to the DVR, a Subnet mask of 255.255.255.000, and a default gateway of 192.168.001.001.

- The next step is to get the computer onto the same network to do this you will need administrator access to your windows machine.
- To assign a static IP address in windows 2000/XP.



- Double-click on **Network Connections**

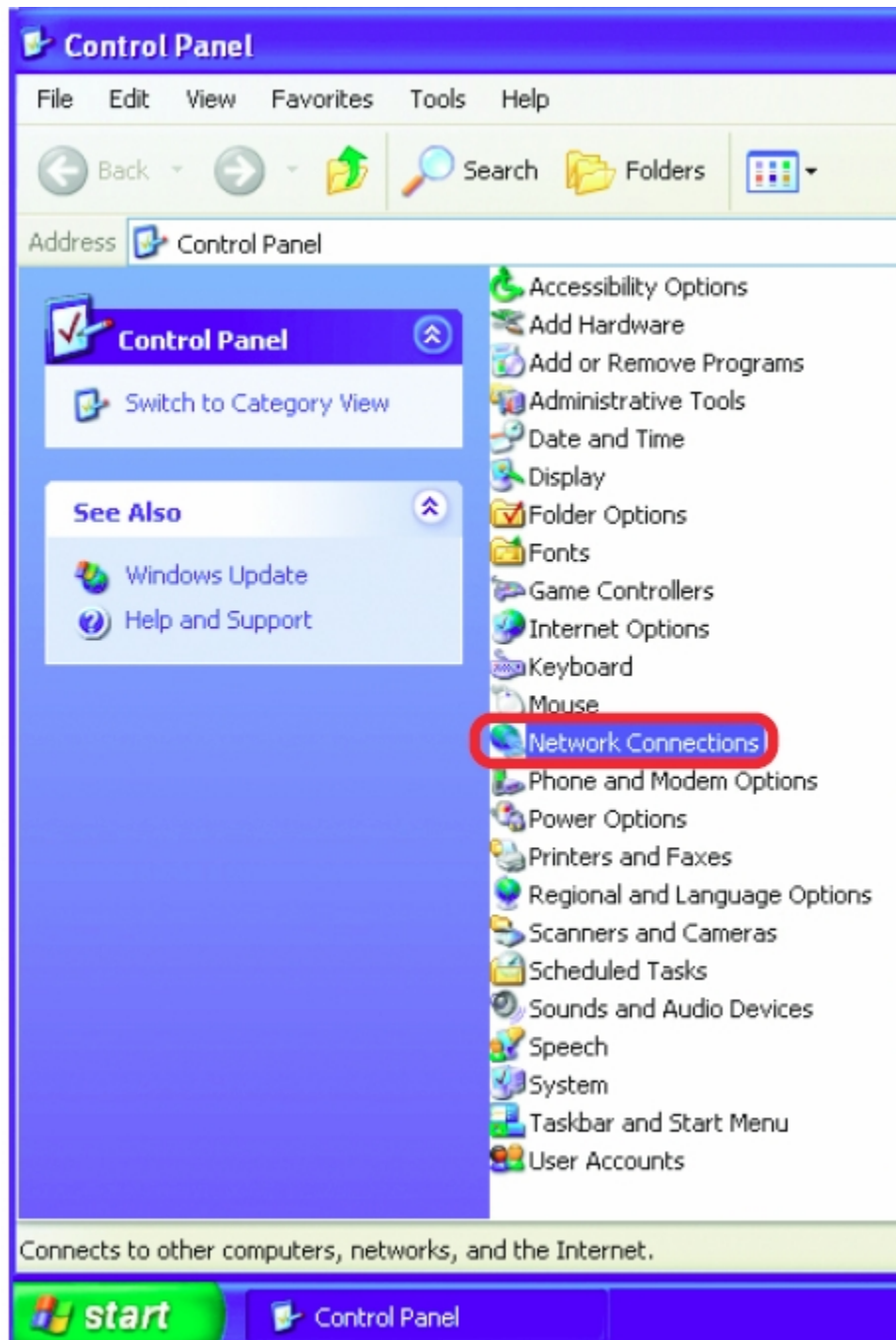

- Right-click on **Local Area Connections**

- Double-click on **Properties**

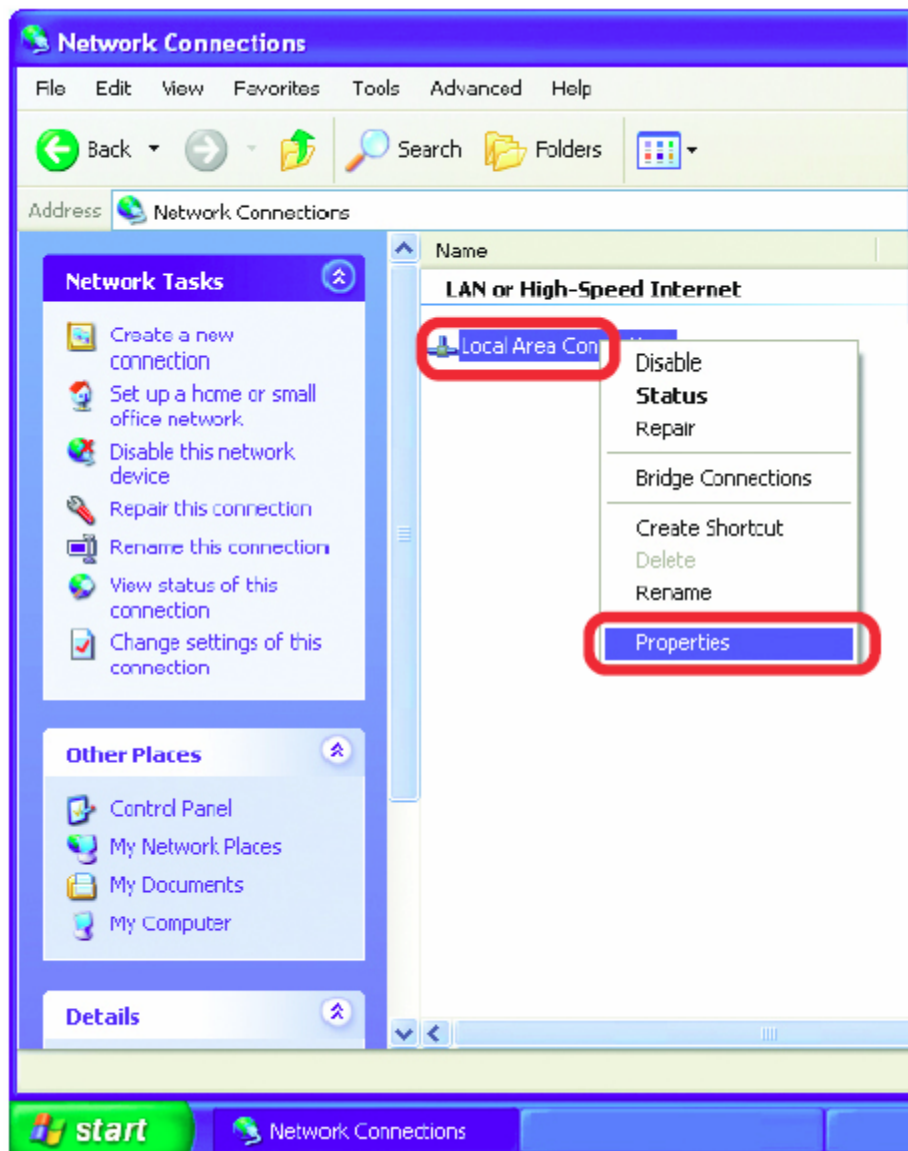

- Click on **Internet Protocol (TCP/IP)**
- Click **Properties**

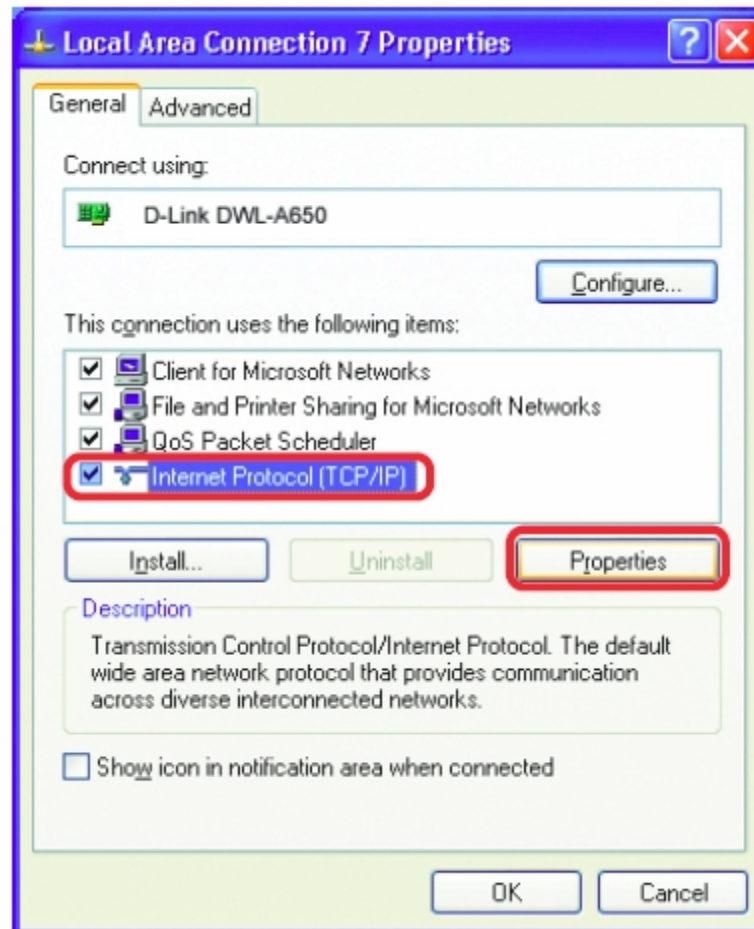

- Input your **IP address and subnet mask.** (The IP Addresses on your network must be within the same range.

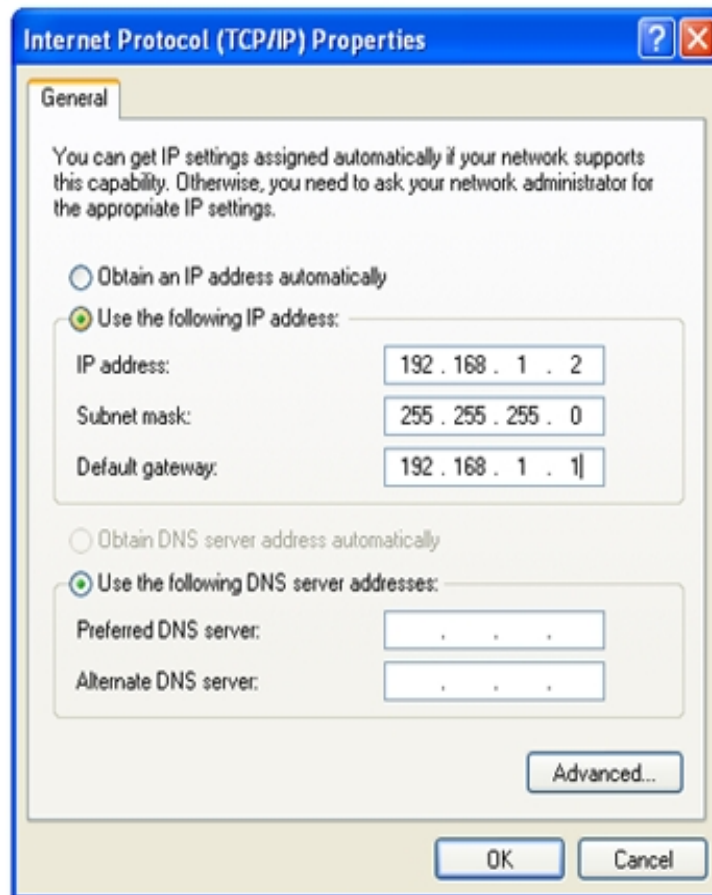

- Once you have reached this point click ok and restart both the computer and the digital recorder.
- To access the DVR from the computer simply open Internet Explorer and in the address bar type:

<http://192.168.1.3>

10.8 Direct High Speed Modem Connection

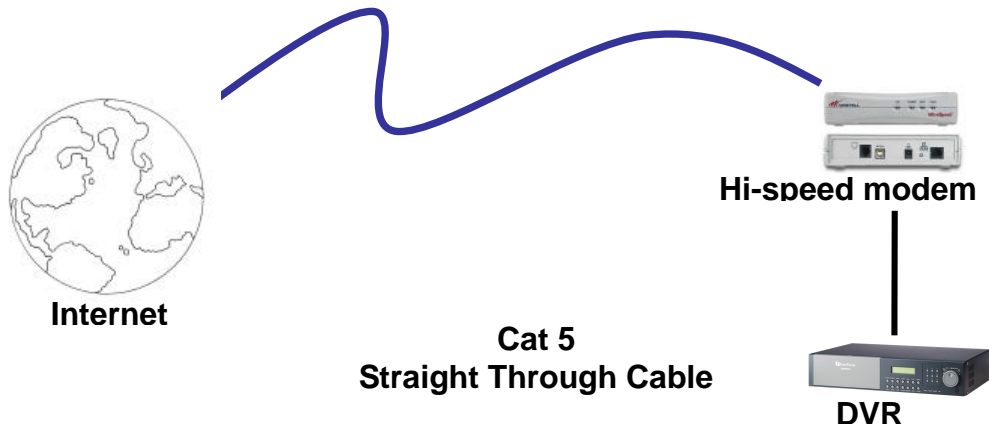

Straight Through Ethernet Cable Pin outs:

The Diagram below shows the pin configurations for a straight cable.

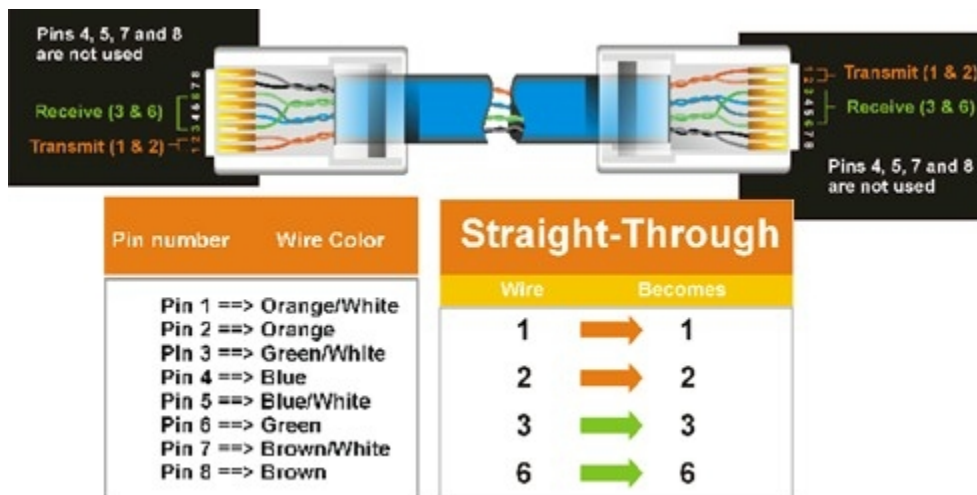

Diagram 10.2

Connection Procedure:

- The First step is to purchase or make a straight through cable. We recommend purchasing one if you have never made a straight through cable. Please remember you can not use a cross over network cable for this application
- Once you have a straight through cable plug one end into the LAN port on the back of the recorder and the other into the high speed modem.

- Now Log into the EverFocus DVR menu and using the jog dial from the previous chapter go to the Network Setting Menu.
- Assign the Static IP address which you obtained from the internet service provider to the DVR, the Subnet mask from the internet service provider to the DVR, and the default gateway of the internet service provider.
 - ***Note: If you have a dynamic IP address this type of connection will not work for you. You will need to purchase a router or ask your internet service provider for a static IP address. (Please refer to local area network connection checklist)***
- Once you have reached this point click ok and restart both the computer and the digital recorder.
- To access the DVR from a computer simply open Internet Explorer and in the address bar type:

http:// and the IP address of your internet service provider.

10.9 Router or LAN Connection

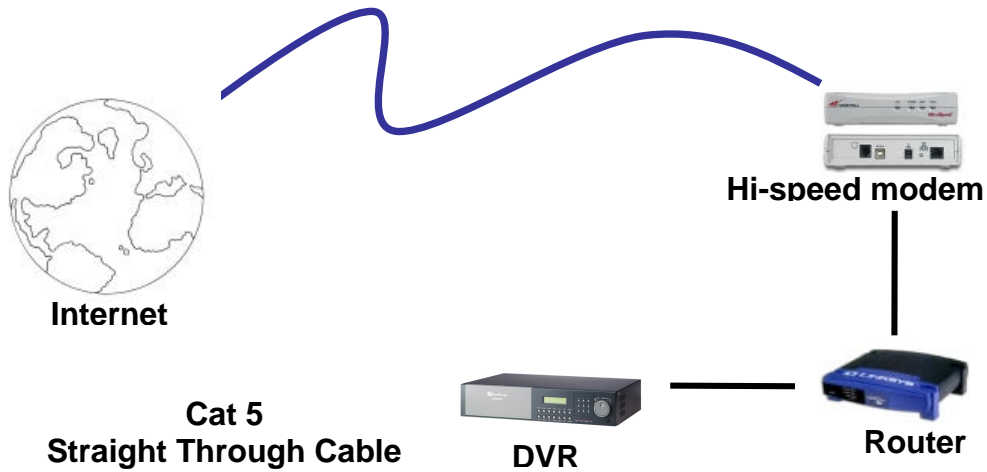

Straight Through Ethernet Cable Pin outs:

The Diagram below shows the pin configurations for a straight cable.

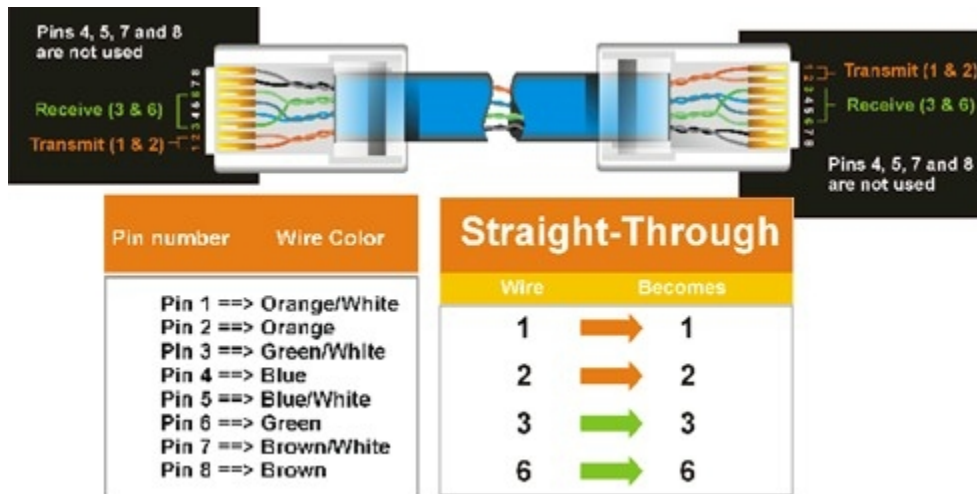

Diagram 10.3

Connection Procedure:

- The First step is to purchase or make a straight through cable. We recommend purchasing one if you have never made a straight through cable. Please remember you can not use a cross over network cable for this application
- Once you have a straight through cable plug one end into the LAN port on the back of the recorder and the other into the router.
- Now Log into the EverFocus DVR menu and using the jog dial from the previous chapter go to the Network Setting Menu.
- If you have a Linksys Router:
 - Assign an IP address of 192.168.001.050 to the DVR, a Subnet mask of 255.255.255.000, and a default gateway of 192.168.001.001.

If you have a D-Link Router:

- Assign an IP address of 192.168.000.050 to the DVR, a Subnet mask of 255.255.255.000, and a default gateway of 192.168.000.001.

If you have a pre-existing LAN:

- Go to a Computer on the pre-existing network and do the following:
 - Go to Start, then Run and type cmd and click on OK.
- Then hit enter, type ipconfig and press enter this will give you the information you will need.



```
C:\WINDOWS\system32\cmd.exe
Microsoft Windows XP [Version 5.1.2600]
(C) Copyright 1985-2001 Microsoft Corp.
C:\Documents and Settings\Arai>ipconfig

Windows IP Configuration

Ethernet adapter Local Area Connection:

    Connection-specific DNS Suffix  . :
    IP Address. . . . .                :
    Subnet Mask . . . . .              :
    Default Gateway . . . . .          :

C:\Documents and Settings\Arai>_
```

- Use the prior step to assign an IP address. For example, if you got the IP address from the computer of 192.168.002.101. Assign the DVR's IP address as 192.168.002.050. Now Copy the subnet mask and default gateway information you got from the prior step off the computer to the DVR.
 - ***Note: Make sure the modem is in bridge mode. If your Internet Service Provider is BellSouth you will have a modem/router. BellSouth provides a Westell modem that includes a built-in router. You will need to disable the router functionality.***
- The next step is to open ports within your router. Open virtual ports in the router (Log into the router using a PC)
- EDR Ports to open: 80, 1600, 37260, 37261, 37262, 37263
 - ***Note: If your Internet service provider blocks port 80 you may use a different port to access the DVR through the DVR's Network Menu Setup.***
 - ***Note: If you wish to have multiple users log into the DVR please open a range for the control and data ports on your router. For example if you would only like 4 clients to connect to the DVR open 1600 and 37260 ~ 37263***
- If you have a Dynamic IP address and have open the ports simply go to Chapter 9 to Configure DDNS.
- Once you have reached this point and you have restarted the digital recorder.
- To access the DVR from a computer simply open Internet Explorer and in the address bar type:
- http:// and the IP address of your internet service provider.
- ***Note: If your Internet service provider blocks port 80 you may use a different port to access the DVR through the DVR's Network Menu Setup.***

11. Linksys Port Forwarding

This chapter will cover a few simple configurations for the Linksys router. Please understand we do not support this product and will not give tech support on it. If you need technical support on this router you must call Linksys. This chapter is to offer some help to the installer and end user, nothing more.

To access the Web-based Utility, launch Internet Explorer or Netscape Navigator, and enter the Router's default IP address, **192.168.1.1**, in the *Address* field. Then, press **Enter**. A password request page will appear. (Non-Windows XP users will see a similar screen.) Leave the *User Name* field blank. The first time you open the Web-based Utility, use the default password **admin**. (You can set a new password from the Administration tab's *Management* screen.) Click the **OK** button to continue.



The first screen that appears displays the Setup tab. This allows you to change the Router's general settings. Change these settings as described here and click the **Save Settings** button to apply your changes or **Cancel Changes** to cancel your changes.

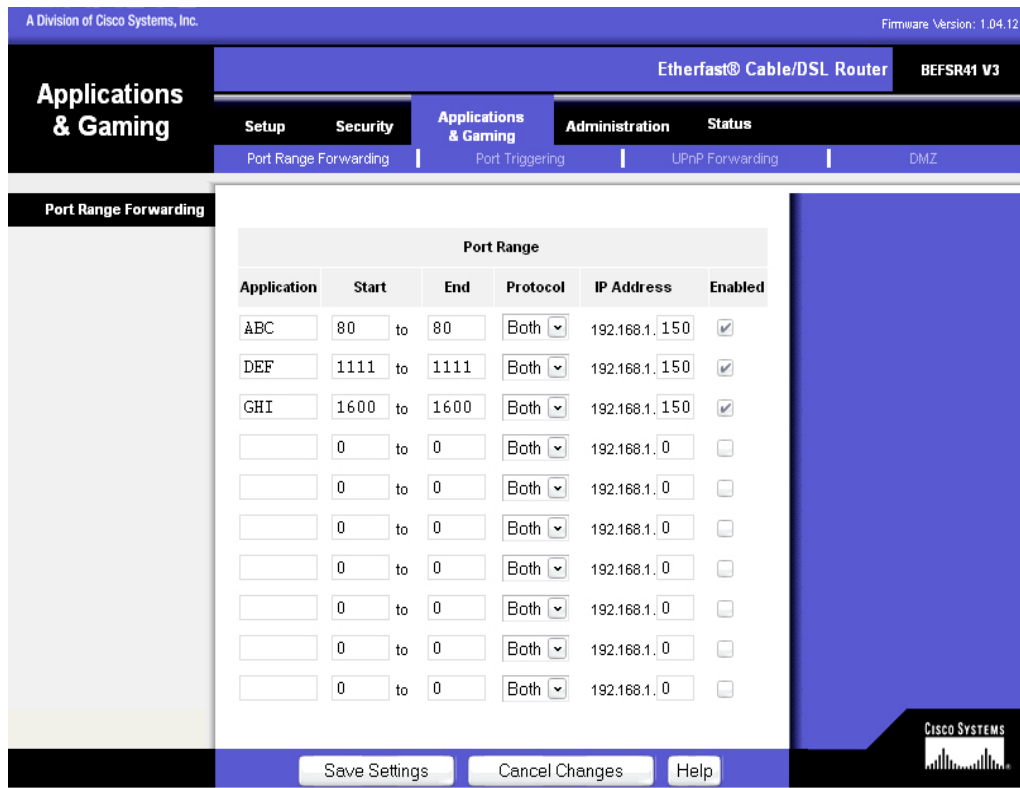

Sample Screen

The Applications and Gaming Tab allows you to set up public services on your network, such as web servers, ftp servers, e-mail servers, or other specialized Internet applications. (Specialized Internet applications are any applications that use Internet access to perform functions such as videoconferencing or online gaming. Some Internet applications may not require any forwarding.)

To forward a port, enter the information on each line for the criteria required. Descriptions of each criteria are described here.

Application - In this field, enter the name you wish to give the application. Each name can be up to 12 characters.

Start/End - This is the port range. Enter the number that starts the port range under **Start** and the number that ends the range under **End**.

Protocol - Enter the protocol used for this application, either **TCP** or **UDP**, or **Both**.

IP Address - For each application, enter the IP Address of the PC running the specific

application.

Enable - Click the **Enable** checkbox to enable port forwarding for the relevant application.

Change these settings as described here and click the **Save Settings** button to apply your changes or **Cancel Changes** to cancel your changes.

Example:

DVR	80 to 80	Both	192.168.1.50	Enable
DVR	1600 to 1600	Both	192.168.1.50	Enable
DVR	37260 to 37260	Both	192.168.1.50	Enable

- *Note: If your Internet service provider blocks port 80 and you are using a different port to access the DVR through the DVR's Network Menu Setup please open those specific ports in this section of the router.*

The following is the address you would type:

http:// IP address of your internet service provider: 8100

Dynamic DNS

The Router offers a Dynamic Domain Name System (DDNS) feature. DDNS lets you assign a fixed host and domain name to a dynamic Internet IP address. It is useful when you are hosting your own website, FTP server, or other server behind the Router. Before you can use this feature, you need to sign up for DDNS service at www.dyndns.org, DDNS service providers.

DDNS Service - From this pull-down menu, enter the DDNS service with which you have membership.

User Name - Enter the User Name for your DDNS account.

Password - Enter the Password for your DDNS account.

Host Name - There is the DDNS URL assigned by the DDNS service.

Internet IP Address - This is the Router's current IP Address as seen on the Internet.

Status - This displays the status of the DDNS connection.

Change these settings as described here and click the **Save Settings** button to apply your changes or **Cancel Changes** to cancel your changes.

The screenshot shows the Linksys web interface for configuring DDNS. The top navigation bar includes the Linksys logo, "A Division of Cisco Systems, Inc.", and the firmware version "1.04.12". The main navigation menu is divided into "Setup" (selected), "Security", "Applications & Gaming", "Administration", and "Status". Under "Setup", there are sub-menus for "Basic Setup", "DDNS" (selected), "MAC Address Clone", and "Advanced Routing". The "DDNS" section is active, showing the "DynDNS.org" service selected. The configuration fields include "User Name", "Password", and "Host Name", all of which are empty. The "Internet IP Address" is displayed as "129.44.56.193". The status message reads "DDNS server is currently closed." At the bottom, there are three buttons: "Save Settings", "Cancel Changes", and "Help". The Cisco Systems logo is visible in the bottom right corner.

LINKSYS®
A Division of Cisco Systems, Inc. Firmware Version: 1.04.12

Etherfast® Cable/DSL Router BEFSR41 V3

Setup

Setup Security Applications & Gaming Administration Status

Basic Setup | DDNS | MAC Address Clone | Advanced Routing

DDNS

DynDNS.org

DDNS Service: DynDNS.org

User Name:

Password:

Host Name:

Internet IP Address: 129.44.56.193

Status: **DDNS server is currently closed.**

Save Settings Cancel Changes Help

CISCO SYSTEMS

12. D-Link Port Forwarding

This chapter will cover a few simple configurations for the D-Link router. Please understand we do not support this product and will not give tech support on it. If you need technical support on this router you must call D-Link. This chapter is to offer some help to the installer and end user, nothing more.

Whenever you want to configure your network or the DI-624, you can access the Configuration Menu by opening the web-browser and typing in the IP Address of the DI-624. The DI-624 default IP Address is shown at right:

- Open the web browser
- Type in the **IP Address** of the Router (<http://192.168.0.1>)

Note: if you have changed the default IP Address assigned to the DI-624, make sure to enter the correct IP Address.

- Type **admin** in the **User Name** field
- Leave the **Password** blank
- Click **OK**

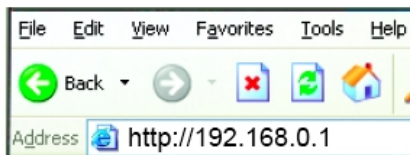

- The next step is to open ports within your router. Go to Virtual Server in the router.

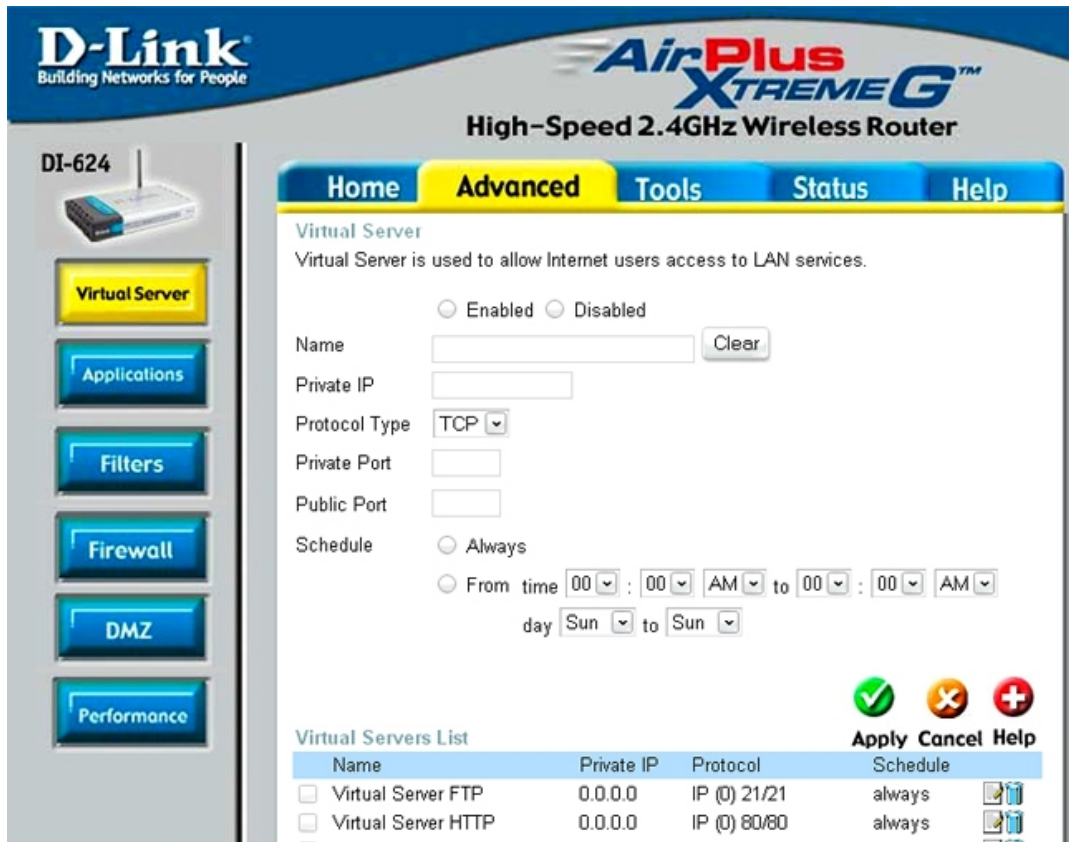

Example1:

Protocol Type - The protocol used for the virtual service.

Public Port - The port number on the WAN (Wide Area Network) side that will be used to access the virtual service.

Private Port - The port number of the service used by the Private IP computer.

Schedule - The schedule of time when the virtual service will be enabled. The schedule may be set to **Always**, which will allow the particular service to always be enabled. If it is set to **Time**, select the time frame for the service to be enabled. If the system time is outside of the scheduled time, the service will be disabled.

Virtual Server - Select **Enabled** or **Disabled**

Name - Enter the name referencing the virtual service

Private IP - The server computer in the LAN (Local Area Network) that will be providing the virtual services. If you have a Web server that you wanted Internet users to access at all times, you would need to enable it. Web (HTTP) server is on LAN (Local Area Network) computer

192.168.0.50 HTTP uses port 80, TCP and UDP.

Name: DVR

Private IP: 192.168.0.50

Protocol Type: Both

Private Port: 80

Public Port: 80

Schedule: always

- The next step is to open ports within your router. Open virtual ports in the router.
 - EDR Ports to open: 80, 1600, 37260, 37261, 37262, 37263
 - *Note: If your Internet service provider blocks port 80 and you are using a different port to access the DVR through the DVR's Network Menu Setup please open those specific ports in this section of the router.*
- If your Internet Service Provider Blocks port 80. Simply do the following:
 - Change the HTTP port from 80 to 8100 in the **NETWORK MENU**.
- To access the DVR from a computer simply open Internet Explorer and in the address bar type:

The following is the address you would type:

http:// IP address of your internet service provider: 8100

Dynamic DNS

Dynamic Domain Name System is a method of keeping a domain name linked to a changing IP Address. This is a useful feature since many computers do not use a static IP address.

- To setup Dynamic DNS simple go to Tools and the Misc. At the bottom of the screen you will be able to enable DynDNS.

- Once you have enabled it enter the server address of DynDNS.org:
members.dyndns.org
- Then enter the hostname you created with DynDNS.org
Example: Everfocus.homeip.net
- Then enter the username and password you use to log into DynDNS.org

D-Link
Building Networks for People

AirPlus Xtreme G™
High-Speed 2.4GHz Wireless Router

DI-624

Home Advanced **Tools** Status H

Ping Test
Ping Test is used to send "Ping" packets to test if a computer is on the Internet.

Host Name or IP address

Restart Device
Reboots the DI-624.

Block WAN Ping
When you "Block WAN Ping", you are causing the public WAN IP address on the 624 to not respond to ping commands. Pinging public WAN IP addresses is a common method used by hackers to test whether your WAN IP address is valid.

Discard PING from WAN side Enabled Disabled

UPNP Settings
 Enabled Disabled

Gaming Mode
 Enabled Disabled

VPN Pass-Through
Allows VPN connections to work through the DI-624.

PPTP Enabled Disabled
IPSec Enabled Disabled

Dynamic DNS

DDNS Enabled Disabled

Server Address

Host Name

Username

Password

13. EverFocus DDNS Setup

*Note: You **MUST** have firmware version 1.6.2 or higher in order to use the EverFocus DDNS server.*

- Set up the Network Menu according to the instructions detailed in the Networking chapter.
- Go to the website <http://everfocusddns.com> and check for an available name.



The screenshot shows the EverFocus DDNS Service Site interface. At the top left is the EverFocus logo. At the top right, it says "DDNS SERVICE SITE" and "Welcome Guest!". Below this is a section titled "Check Available Host Name". There is a text input field containing ".everfocusddns.com" and a "Check" button below it.

- In DVR's Network Menu, go to DDNS. Choose "everfocusddns.com" for the Server and put in your chosen name for DVR Name.

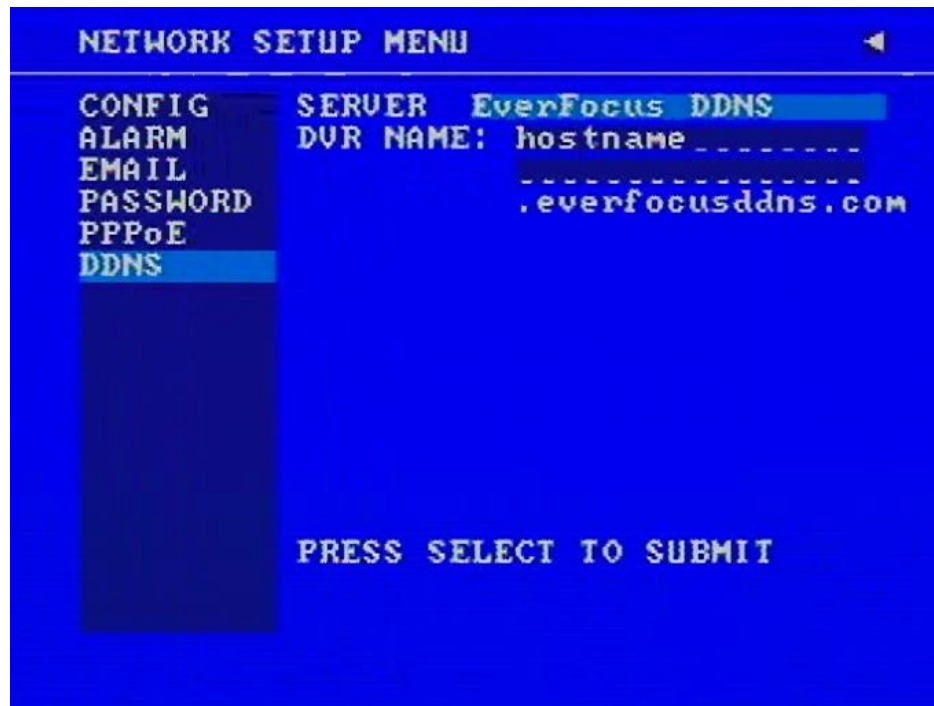

- Press the Select button to synchronize the DVR with the DDNS server. You should see the word "Success" at the bottom of the screen. If you see "Could Not Find Server" instead, double check your network settings until you get "Success".
- You should now be able to connect by typing in the host name you created.
Example: <http://hostname.everfocusddns.com>

14. Viewing through Internet Explorer

- To access the DVR from a computer simply open Internet Explorer and in the address bar type:

http:// (LAN address or IP address of your internet service provider)

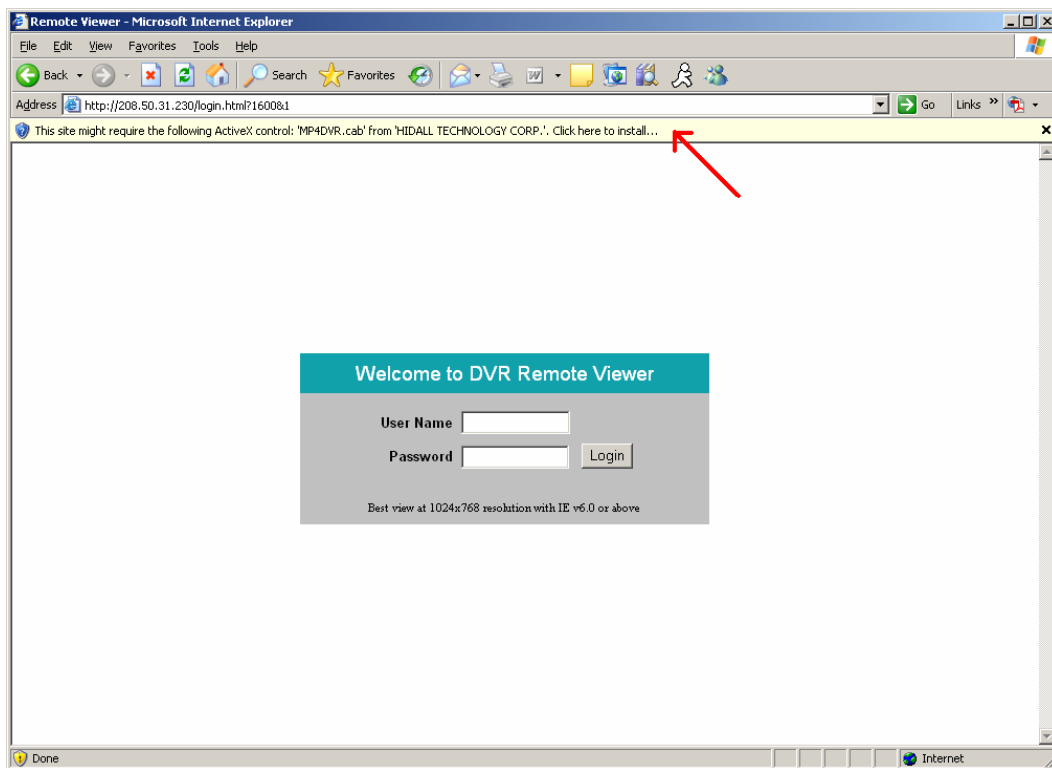

- After a few seconds, you should see a screen like the one above. If you do not see a yellow bar like the one the arrow is pointing at, your security settings may be too high. If so, go to the section labeled “Enabling ActiveX Controls.”
- Right click on the yellow bar and select “Install ActiveX Control...”
- Install the MP4DVR file when prompted to do so.

- User must enter a user name and password to access the recorder. User Name and Password can be found and changed in the Network Menu of the DVR.

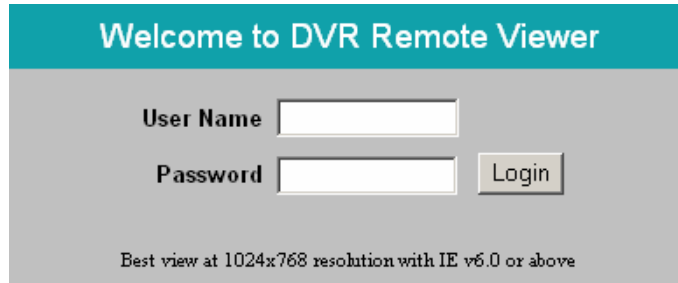

Best view at 1024x768 resolution with IE v6.0 or above

- The Default user name is admin and password is 1111111. Click Login to view the cameras.

Enabling ActiveX Controls

Note: This section is only necessary if you DO NOT see the yellow ActiveX bar at the top of your browser screen.

- At the top of the Internet Explorer Window, click on Tools, then select Internet Options.

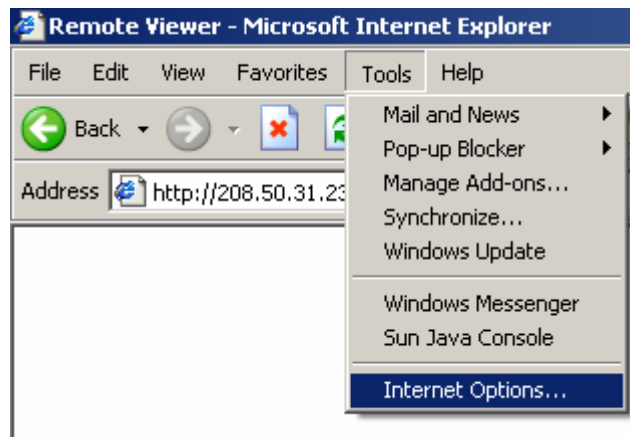

- Click the Security tab at the top, then choose Custom Level near the bottom.

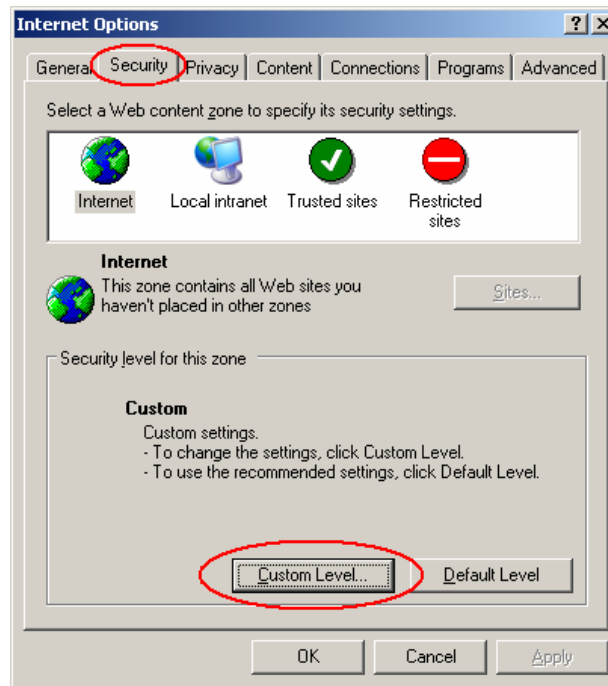

- In the Security Settings window, scroll to “ActiveX controls and plug-ins”. Set the controls as follows:

“Enable”:

- ✓ Allow previously unused ActiveX controls to run without prompt (Internet Explorer 7 only)
- ✓ Allow scriptlets (IE7 only)
- ✓ Automatic prompting for ActiveX controls
- ✓ Binary and script behaviors
- ✓ Display video and animation on a webpage that does not use external media player (IE7 only)
- ✓ Run ActiveX controls and plug-ins
- ✓ Script ActiveX controls marked safe for scripting

“Prompt”:

- ✓ Download signed ActiveX controls
- ✓ Download unsigned ActiveX controls

“Disable”:

- ✓ Initialize and script ActiveX controls not marked as safe

- Click OK and then choose Yes to change the security settings. Close the window so you are back at the DVR Viewer screen.

- Click the Refresh button to reload the page and install the MP4DVR file when prompted to do so.

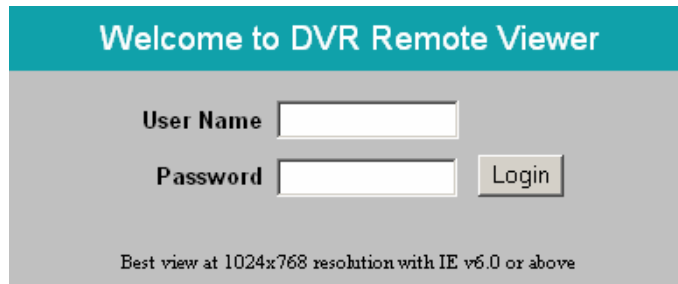

- Type in the username and password and click Login to view the cameras.

Main Screen:

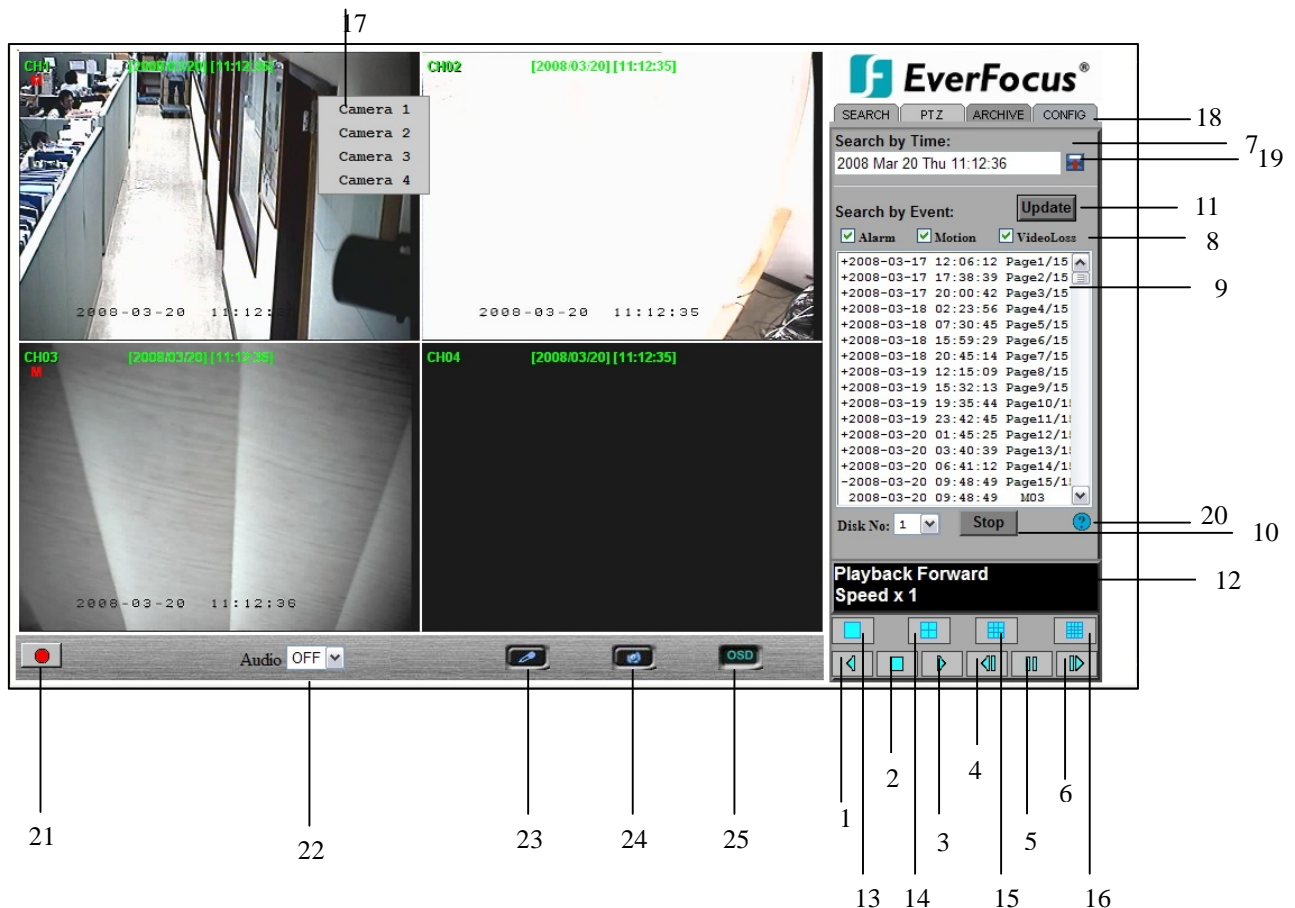







The above diagram is the main screen display.

The icons in the right corner of the screen are mainly for control and configuration; those on the left side are for status indication.

If any icon is grayed, it means that the specific function is not accessible in the current mode.

The followings are a brief description for each of the icons.

1.  **REV. PLAY:** Reverse Video Playback.
2.  **STOP:** Press this key to stop Playback and return to Live mode.
3.  **PLAY:** Normal Video Playback.
4.  **STEP BACKWARD:** Move one frame back while paused.
5.  **PAUSE:** To pause the Video Playback display.
6.  **STEP FORWARD:** Move one frame forward while paused.
7. Search Section. There are two methods of searching past video: by **Event** and by **Time**.
8. Types of events to be searched: **Alarm**, **Motion** and/or **Vloss**.
9. All available events are shown in the list. Click the desired event to highlight it.
10. Click on “**Play**” to play back highlighted video event.
11. Press “**Update**” to refresh the event list.
12. Current connection and playback status are shown along with date and time.
13. Full screen view.
14. Quad screen view.
15. Nine split screen view (not available for 4 channel units).
16. Sixteen split screen view (reserved for 16 channel units only).
17. If you right-click on a camera screen, a drop-down list of available cameras appears. Click on the desired camera to display it in that view screen.
18. There are 4 main functions of Remote Viewer: **SEARCH**, **PTZ**, **ARCHIVE** and **CONFIG**. **SEARCH** section allows you to search by event or by time. **PTZ** section allows you to control PTZ cameras. **ARCHIVE** section allows you to remotely archive files or download DVRViewer. **CONFIG** section allows you to make system changes remotely.
19. **Pick a date:** Click on the blue box to open the detailed time search box.

20. **Event Description:** By clicking on the  sign, an event description list will show up as follow:

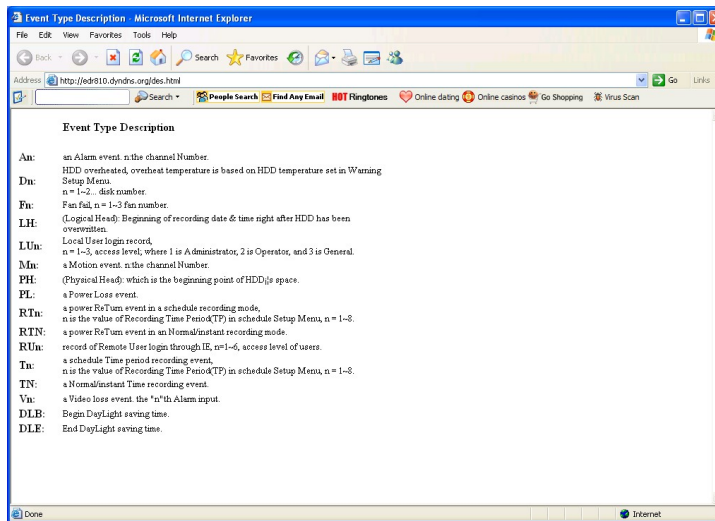

21. **Record:** Press the button to remotely activate the DVR's record function. Press again to stop recording.

22. **Audio:** This function allows you to transmit audio from DVR to your PC's remote site. Select audio source 1/2/3/4, or "OFF" to disable this function.

23. **Audio Broadcast:** This function is designed to transmit audio (through a microphone) to DVR that has speaker device installed. Keep pressing this button whenever you need to do audio broadcasting. Release this button to stop transmitting audio to DVR.

24. **Relay Output:** Press the button to trigger relay output.

25. **OSD:** Press to show OSD information, including camera name, date, time, and event type. Press again to hide them.

14.1 SEARCH

14.1.1 Search by Time

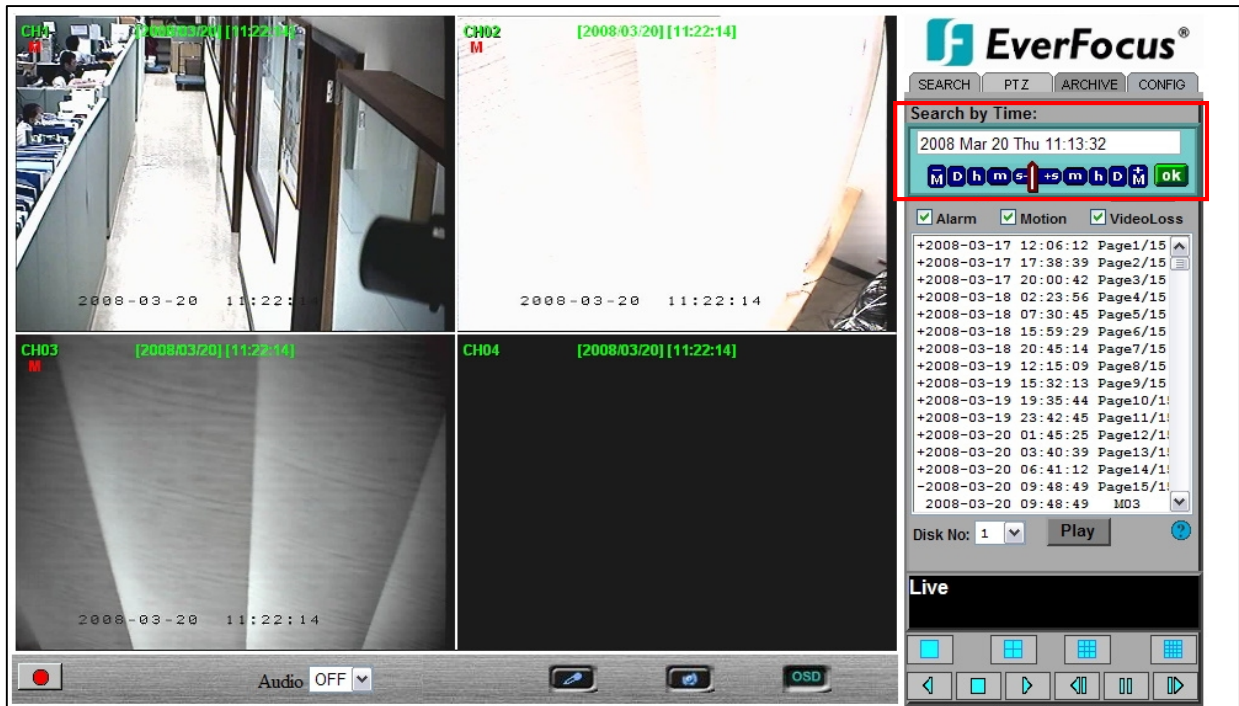

There are 3 ways to do search by time. First press 

1. Press the **M** button to change the month to be searched, **D** for day, **h** for hour, **m** for minute and **s** for second. The buttons on the left-hand side are to decrease the value, whereas those on the right-hand side are to increase the value.
2. Move the slide bar between the buttons to change Month, Day, Hour, Minute, and Second to be searched. Move the slide bar to the left to decrease the value, or to the right to increase the value.
3. Enter Month, Day, Hour, Minute, and Second directly in display bar. Press **OK** to start searching.



14.1.2 Search by EVENT

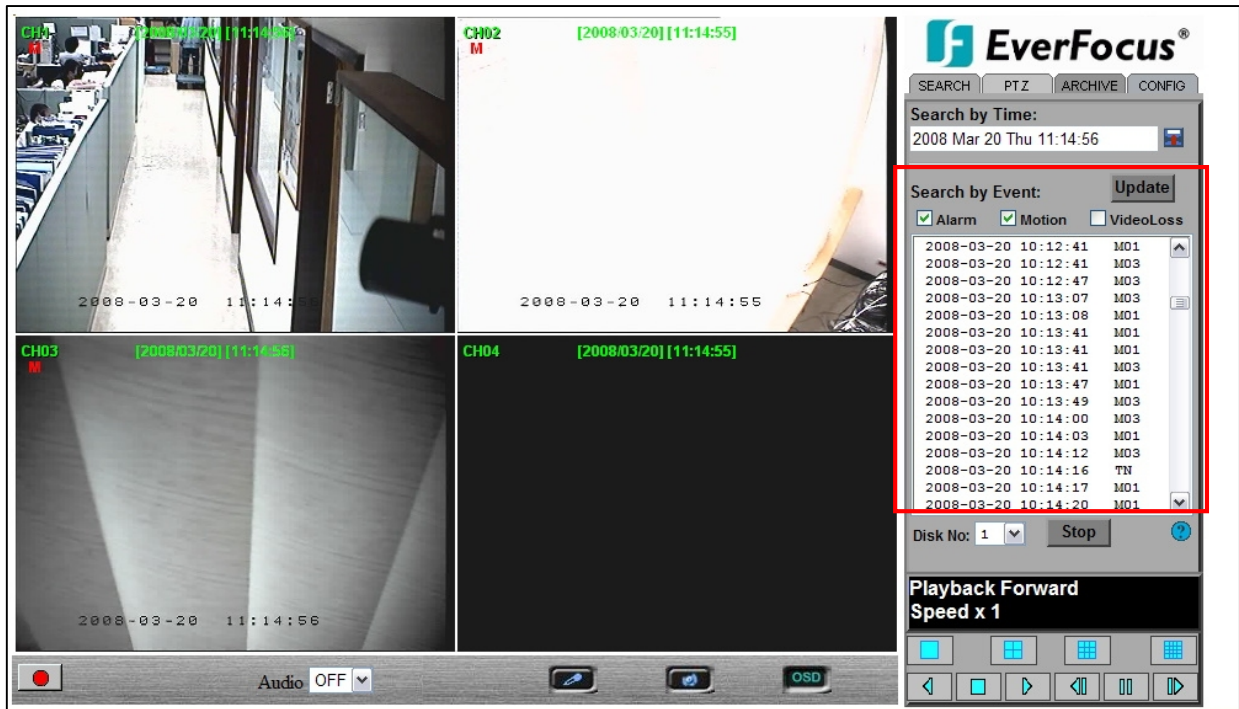

1. Select Event Type from **Alarm**, **Motion** and **Vloss**.

Note: At least one event type must stay checked.

2. Select the **Disk No.** from which you would like to search events.
3. Press **Update** button to refresh the event list.
4. All events of the selected type will be displaying along with Date/Time, event type (represented by a capital letter), and camera number (represented by a number)
For example, M02 is a motion event from camera 2.
5. When there is a "+" sign in front of the date with page number at the end, double-click to show all the events of that page.
6. Press **Play** button to playback the selected event.
7. Press **Stop** button to stop playback.

14.2 PTZ control

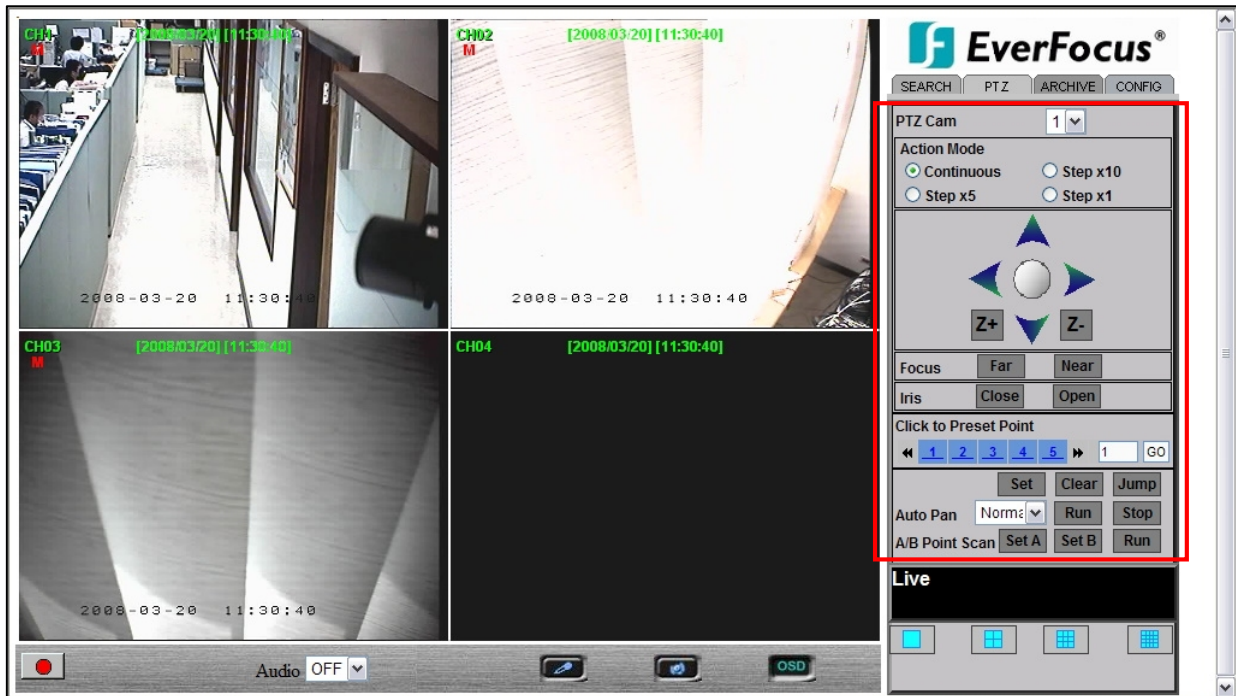

1. Select the PTZ camera you wish to control from drop-down menu.
2. Select **Action Mode** you want to use. There are 4 options available: **Continuous**, **Step x10**, **Step x5** and **Step x1**.
3. Use Direction Arrows (up, down, left, right) to move/adjust the focus to your desired direction and angle.
4. Press **Z+** for Zooming In or **Z-** for Zooming Out.
5. In **Focus** option, press **Near** to move the focus closer to the subject or press **Far** to move the focus farther from the subject.
6. You can turn on the **Iris** by pressing **Open** or turn it off by pressing **Close**.
7. “**Click to Preset Point**” helps you to define the preset point you want the camera to look at. Press **Set** to confirm, **Clear** to delete or **Jump** to jump to a specific point.
8. “**Auto Pan**” is to define the speed of PTZ camera when moving horizontally. Choose from **Slower**, **Slow**, **Normal**, **Fast** to **Faster**. Press **Run** to start or **Stop** to end.
9. “**A/B Point Scan**” allows you to set a tour between 2 points. Move to the first point by using direction arrows and press **SET A**. Then move to the second point by using direction arrows and press **SET B**. Press **RUN** to start A/B Point Scan.

14.3 REMOTE ARCHIVE

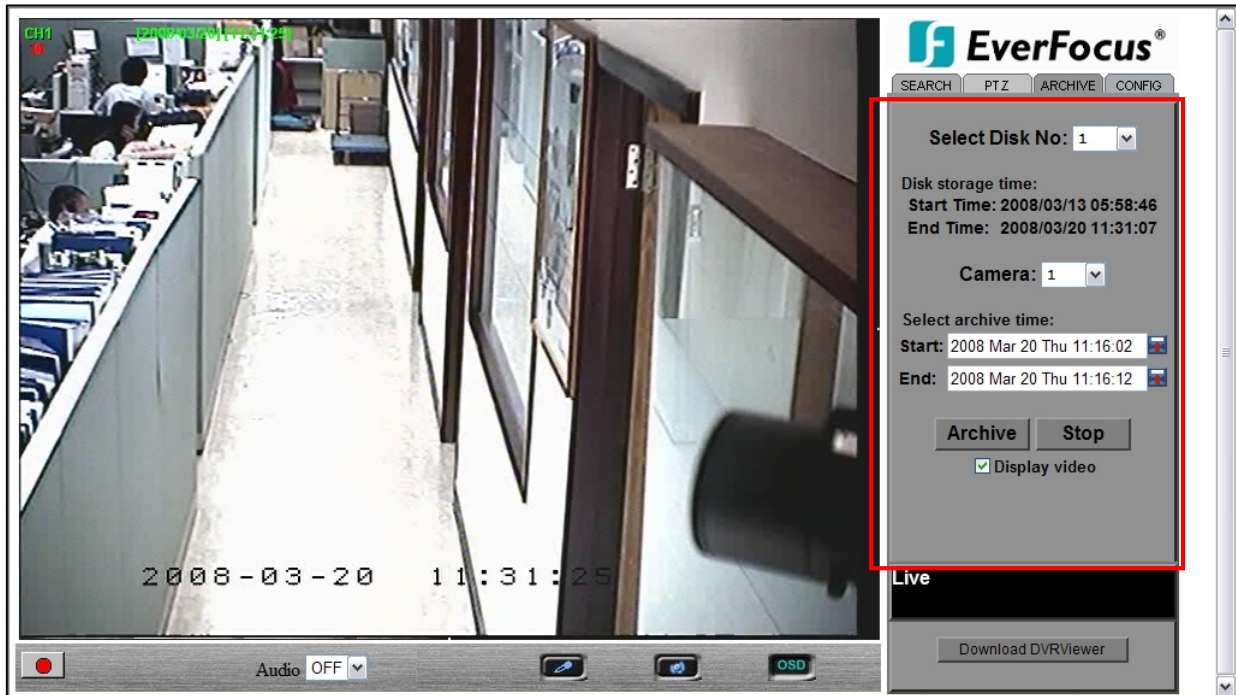

To Archive files:

1. **Select Disk No.:** The hard drive you want to archive from
2. **Disk Storage Time: Start Time/End Time** indicates the start and end time of the selected disk
3. **Camera:** Select the camera that you wish to archive from.
4. **Start:** Select the start time of the archived video.
5. **End:** Select the end time of the archived video.

There are 3 ways to search either **Start** or **End** time to be archived. Press  first.

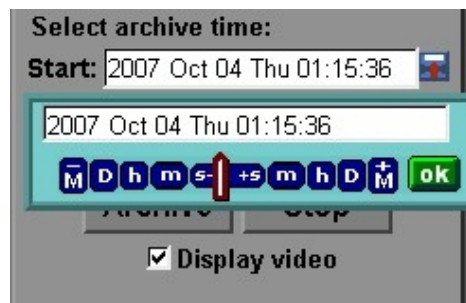

- 1) Press on the **M** button to change the month to be searched, **D** for day, **h** for hour, **m** for minute and **s** for second. The buttons on the left side are to decrease the value, whereas those on the right side are to increase the value.
 - 2) Move the slide bar between the buttons to change Month, Day, Hour, Minute, and Second to be searched. Move the slide bar to the left to decrease the value, or to the right to increase the value.
 - 3) Enter Month, Day, Hour, Minute, and Second directly in display bar.
 - 4) Press **OK** to select time.
6. Press **ARCHIVE** button to start archiving. An **“.arv”** file will be saved.
 7. Press **STOP** button if you wish to cancel archiving.
 8. Check **“Display video”** if you wish to display what you are archiving on the screen while archiving file at same time.

SEARCH PTZ ARCHIVE CONFIG

Select Disk No: 1

Disk storage time:
Start Time: 2008/03/13 05:58:46
End Time: 2008/03/20 11:31:07

Camera: 1

Select archive time:
Start: 2008 Mar 20 Thu 11:16:02
End: 2008 Mar 20 Thu 11:16:12

Archive Stop

Display video

In order to play the archived EDR MPEG4 Files (.arv), you will need to download viewer:

I. Press **Download DVRViewer** button.

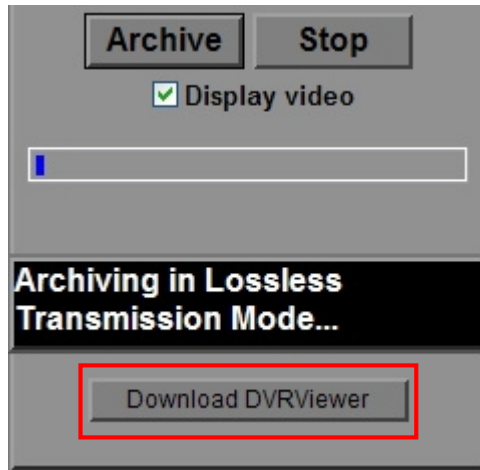

II. Select “**Run**” or “**Save**” the file.



III. Open the DVRViewer.exe for loading the archived EDR MPEG Files (.arv)

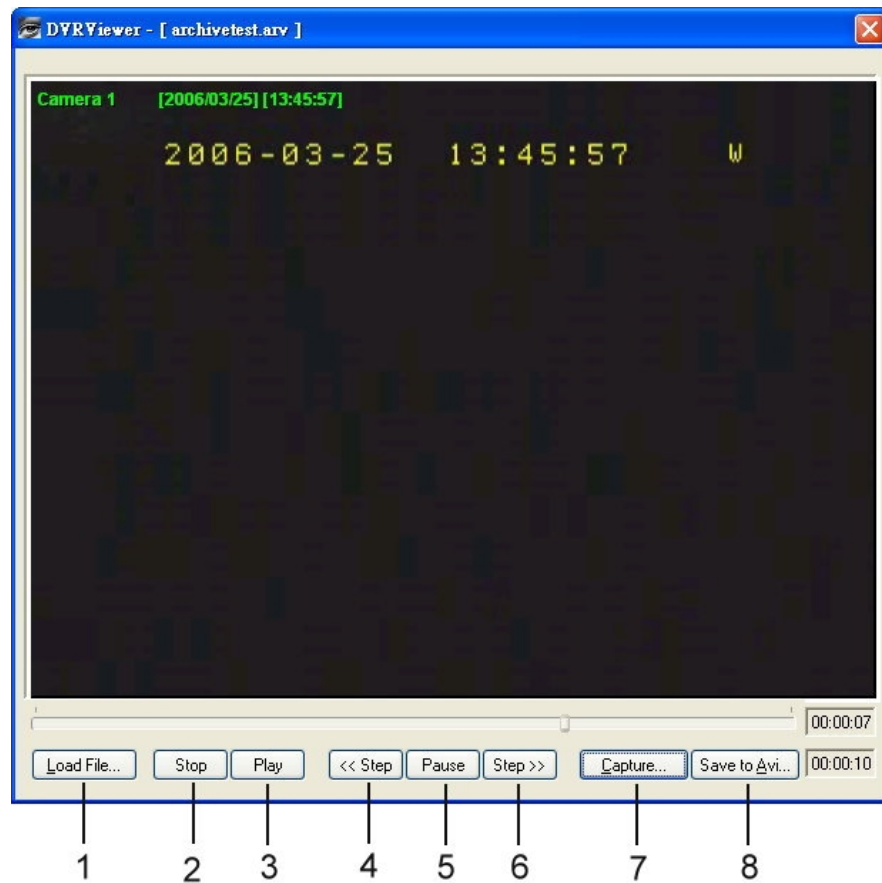

Detailed explanation of DVRViewer is as follows:

1. **Load File:** load an archived EDR MPEG File (.arv).
2. **Stop:** stop playback.
3. **Play:** play video.
4. **<<Step:** move the paused image one step backward.
5. **Pause:** pause playing.
6. **Step>>:** move the paused image one step forward.
7. **Capture:** save the current image as “.jpg” file.
8. **Save to Avi:** save the archived EDR MPEG File as “.AVI” file.

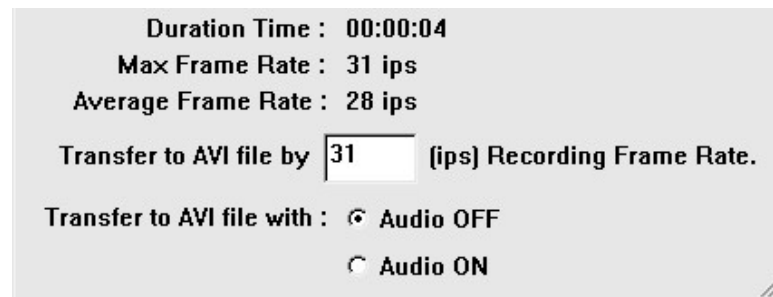

Note:

(1) The recording frame rate will be automatically calculated. It is suggested to use the calculated Recording Frame Rate, although it is possible to change this value.

(2) If you wish to save the audio recorded, please select **Audio ON**, so that the audio can be transferred to AVI file. Otherwise, select **Audio OFF**.

Note: If you are unable to play “AVI” file downloaded from “DVRViewer”, your PC may require a video codec.

The codec can be found at the following URL: <http://www.divx.com/divx/windows/codec/>

If you continue to have problems or are unable to download this file, you can also try

<http://www.cole2k.net/?display=Codec-Pack-Advanced>

14.4 Remote Configuration



Click on the “CONFIG” tab to open a page where you can remotely change the DVR’s settings. Click on each option to go to the settings for that page.

When you finish making changes on a screen, press **Apply** to save the settings. Press **Reset** to display the DVR’s current menu settings.

The settings you make remotely in this page are virtually the same as the way you set up the DVR itself, except for as noted in the following pages.

DATE/TIME setup menu

Set Date Time Infomation		Apply	Reset
Time Format	<input checked="" type="radio"/> 24H <input type="radio"/> 12H		
Date Format	YYYY-MM-DD		
Date Light Saving		Apply	Reset
Enable	<input type="checkbox"/>		
Start On	Last Sunday April		
From	02:00 To 03:00		
End On	Last Sunday October		
From	03:00 To 02:00		
Set Time Synchronize		Apply	Reset
Time Synchronize	<input type="checkbox"/>		
Server IP	220 . 130 . 158 . 52		
Time Zone	GMT		
Time Update By	Day		
Set Date Time Manually		Apply	Reset
2008/01/10 10:18:41			

Set Date/Time Manually

1. Click on the calendar button to set Date/Time manually. A calendar will show up as shown below.
2. Click “<<” to decrease Year value, “>>” to increase Year value.
3. Click “<” to decrease Month value, “>” to increase Month value.
4. Click on the selected date directly.
5. Click on the Hour, Minute, Seconds to change Time value. Up arrow for increasing and Down arrow for decreasing the value. This is also used to change between Am and Pm.
6. Finally, click **Apply** to confirm setting.

<<	<	OCT 2007					>	>>
Sun	Mon	Tue	Wed	Thu	Fri	Sat		
		1	2	3	4	5	6	
7	8	9	10	11	12	13		
14	15	16	17	18	19	20		
21	22	23	24	25	26	27		
28	29	30	31					
Time		02:33:13 am						
		Apply						

CAMERA setup menu

⇒ **Set Camera Information** Apply Reset

Camera: 1
 Title: CH01
 Install:
 Covert:
 Quality: High

PTZ ID: 11
 Main Monitor Seq.: 3 Seconds
 Call Monitor Seq.: 3 Seconds

Record Speed And Action

TP	Normal	Event	Action
1	1	30	<input checked="" type="checkbox"/>
2	1	30	<input checked="" type="checkbox"/>
3	1	30	<input checked="" type="checkbox"/>
4	1	30	<input checked="" type="checkbox"/>
5	1	30	<input checked="" type="checkbox"/>
6	1	30	<input checked="" type="checkbox"/>
7	1	30	<input checked="" type="checkbox"/>
8	1	30	<input checked="" type="checkbox"/>
Normal	1	30	<input checked="" type="checkbox"/>

RECORD setup menu

⇒ **Set Record Information** Apply Reset

Record Audio:
 Time Stamp:
 Time Stamp Position: Bottom
 Water Mark:
 Resolution: 720x240
 Rewrite:
 Auto Rewrite Within: 0 Days
 Pre-Alarm Recording:
 Relay Out: NONE

ALARM setup menu

⇒ **Set Alarm Information** Apply Reset

Alarm: 1
 Enable:
 Log:
 PTZ Preset: OFF
 Alarm Output: NONE
 Buzzer:
 Main Monitor: No Change

Alarm Type: N.O.
 Active Camera: 1
 Duration: 05 SEC
 Alarm Email:
 Alarm Network:
 Call Monitor: No Change

MOTION setup menu

⇒ Set Motion Information Apply Reset

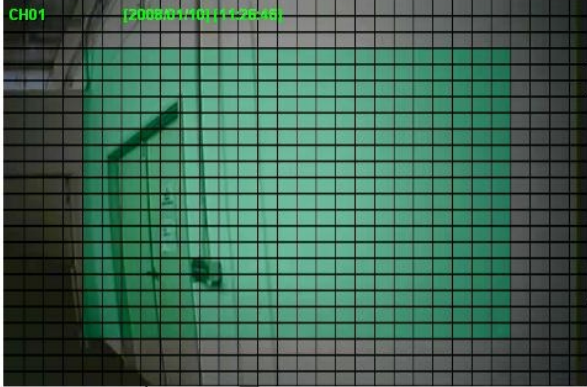

Camera: 1
Enable:
Log:
Alarm Output: NONE
Alarm Network:
Main Monitor: No Change
Motion Delay: 0 Level

Sensitivity: 7
Duration: 5 Seconds
Alarm Email:
Buzzer:
Call Monitor: No Change

Set Motion Grid

1. Non-green squares are disabled for motion; green squares are enabled.
2. Click and hold the mouse to begin selecting squares in the motion grid.
3. Drag the mouse to highlight the desired area.
4. The selected area will switch to the opposite color.
5. Click **Apply** to save the changes.

VIDEO LOSS setup menu

⇒ Set Video Loss Information Apply Reset

Camera: 1
Enable:
Duration: 05 SEC
Alarm Output: NONE
Buzzer:

Log:
Alarm Email:
Alarm Network:

NETWORK 1 setup menu

Network Config Setting (Read Only) Reset			
IP Type	DHCP		
IP Address	192.168.1.148	Net Mask	255.255.255.0
Gateway	192.168.1.1	DNS Server	192.168.1.12
Remote Control	<input checked="" type="checkbox"/>		
HTTP Port	80	Control Port	1600
Data Port	37260	Band width	8192 KB

SMTP Setting Apply Reset	
SMTP Server	
Port No.	25
Authentication	<input type="checkbox"/>
Username	
Password	
Receiver	
Sender	

PPPOE Setting Apply Reset	
Username	
Password
Primary DNS	0.0.0.0
Secondary DNS	0.0.0.0

The Network Configuration Settings can not be changed remotely. These must be changed in the DVR's Network Menu.

NETWORK 2 setup menu

Alarm Network Setting Apply Reset			
Protocol	UDP	Port No.	1600
Unique ID		Server 1	192.168.1.100
Server 2	192.168.1.101	Server 3	192.168.1.102

Network Password Setting Apply Reset		
Account	Password	Level
ADMIN	Admin
USER2	Live
USER3	Live
USER4	Live
USER5	Live
USER6	Live

DDNS Setting Apply Reset	
Server	www.sitelutions.com
Username	
Password	
Record ID	
FQDN	

After saving changes to the account, password, or level, the changes will take effect the next time you log in to the network viewer.

SCHEDULE setup menu

⇒ Set Schedule Information Apply Reset

No.	Day	Start	End	Enable
1.	Daily	00:00	00:00	<input type="checkbox"/>
2.	Daily	00:00	00:00	<input type="checkbox"/>
3.	Daily	00:00	00:00	<input type="checkbox"/>
4.	Daily	00:00	00:00	<input type="checkbox"/>
5.	Daily	00:00	00:00	<input type="checkbox"/>
6.	Daily	00:00	00:00	<input type="checkbox"/>
7.	Daily	00:00	00:00	<input type="checkbox"/>
8.	Daily	00:00	00:00	<input type="checkbox"/>

CONTROL setup menu

⇒ Control Setting Apply Reset

RS232 Setting

Baud Rate Stop Bit
Parity Byte Size

RS485 Setting

Baud Rate Stop Bit
Parity Byte Size

RS232/RS485 ID
PTZ Protocol

WARNING setup menu

Warning Fan Fault				Apply	Reset
Buzzer	<input checked="" type="checkbox"/>				
Alarm Output	1	Duration	Permanent		
Network Alarm	<input type="checkbox"/>	Send EMail	<input type="checkbox"/>		
Warning HDD Temp.				Apply	Reset
Buzzer	<input checked="" type="checkbox"/>				
Alarm Output	1	Duration	Permanent		
Network Alarm	<input type="checkbox"/>	Send EMail	<input type="checkbox"/>		
Stop Record	<input checked="" type="checkbox"/>	Temperature	60 °C		
			140 °F		
Warning No HDD				Apply	Reset
Buzzer	<input type="checkbox"/>				
Alarm Output	1	Duration	05 SEC		
Network Alarm	<input type="checkbox"/>	Send EMail	<input type="checkbox"/>		
Warning HDD Full				Apply	Reset
Buzzer	<input checked="" type="checkbox"/>				
Alarm Output	1	Duration	05 SEC		
Network Alarm	<input type="checkbox"/>	Send EMail	<input type="checkbox"/>		

SYSTEM setup menu

Update Firmware	Apply
Load Factory Default	Apply
Load/Save Configuration	Save Load

All recording should be stopped before making any changes on this menu.

Update Firmware

1. After clicking **Apply**, an “Open File” window appears.
2. Find the folder where the firmware upgrade is saved and choose Open.
3. On the DVR’s monitor, you will see a notice that the firmware is being updated.
Note: DO NOT try to open the menu or make changes at the DVR while this process is happening.
4. When the update is complete, the DVR will reboot automatically.
5. Once “Load System” has finished, the system’s software will be updated. You will need to refresh the network viewer for the changes to take effect.

Load/Save Configuration

1. Clicking **Save** will open a “Save File window.
2. Select the folder you wish to save the configuration file to and then choose Save.
3. Clicking **Load** will open an “Open File” window.
4. Find the folder where your configuration file is saved and then choose Open.

15. Interface Specifications

RS485

This Digital Video Recorder may be controlled by a computer or control keyboard (EKB500) via the RS485 interface. Pin definition of RS-485 connector on DVR back panel is shown in the following picture.

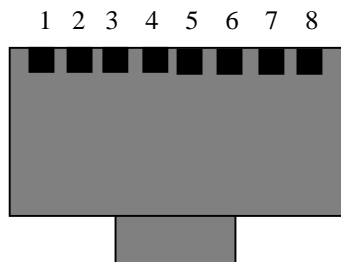

**Pin 3: RS-485 +
Pin 6: RS-485 -**

15.1 Transmission Setting

There are 6 different speeds that can be used to transmit instruction or information through the RS485 port on the device, 1200 baud, 2400 baud, 4800 baud, 9600 baud, 19200 baud, and 38400 baud. The default setting from the factory is 9600 baud.

15.2 Remote Control Protocol

A computer can be used to control the DVR by sending the packet as follows.

485/232 Control Code Protocol

1-1. Sample control code packets

Example1: A packet that send "REC" key to EDR(ID=5)

0x85 (length)
0x00 (Receiver ID high byte)
0x05 (Receiver ID low byte)
0x4B (OPcode = key)
0x08 (DATA1 = "Rec" keycode)
0x5D (checksum)

Example2: A packet that send "PAUSE" key to EDR(ID=4999)

0x85 (length)
0x27 (Receiver ID high byte)
0x07 (Receiver ID low byte)
0x4B (OPcode = key)
0x0C (DATA1 = "Pause" keycode)
0x0A (checksum)

Example3: A packet that send "PLAY" key to all EDR(broadcast)

0x85 (length)
0x7f (Receiver ID high byte)
0x7f (Receiver ID low byte)
0x4B (OPcode = key)
0x0B (DATA1 = "Play" keycode)
0x59 (checksum)

2-1. The format of message packet is as follows:

Length Byte (Prefix: 0x86, 0x87, or 0x88)
Receiver ID high byte
Receiver ID low byte
Opcode Byte
Data Byte1
Data Byte2
Data Byte3
.
.
Checksum Byte

2-2. Length Byte

This Length Byte is also a prefix. Bit7 must be 1.
EX: 0x87 => this packet has 7 bytes length. (not included Length byte itself)

2-3. Receiver ID

1). Individual receiver ID

Decimal	14bit binary value	Hbyte	Lbyte	Receiver ID
0	0000000 0000000	00	00	ID = 0
1	0000000 0000001	00	01	ID = 1
2	0000000 0000010	00	02	ID = 2
....				
126	0000000 1111110	00	7e	ID = 126
127	0000000 1111111	00	7f	ID = 127

128	0000001 0000000	01	00	ID = 128
129	0000001 0000001	01	01	ID = 129
255	0000001 1111111	01	7f	ID = 255
256	0000010 0000000	02	00	ID = 256
....				
511	0000011 1111111	03	7f	ID = 511
....				
16382	1111111 1111110	7f	7e	ID = 16382

2). Broadcast ID

Decimal	14bit binary value	Hbyte	Lbyte	Receiver ID
16383	1111111 1111111	7f	7f	All EDR connect to RS485/RS232

2-4. Opcode Byte & Data bytes

2-4-1. OPcode

OPcode	Data1	Function
0x4B		Keycode A remote key pressed

2-4-1. A remote key pressed (OPcode=0x4B)

Data1	Key for EDR810/EDR410
-------	-----------------------

0x00	CH1
0x01	CH2
0x02	CH3
0x03	CH4
0x04	MODE
0x05	ZOOM
0x06	SEQ
0x07	MENU
0x08	REC
0x09	REV.PLAY
0x0A	STOP
0x0B	PLAY
0x0C	PAUSE
0x0D	SEARCH
0x0E	COPY
0x0F	DISPLAY
0x10	SHUTTLE<<0
0x11	SHUTTLE<<1
0x12	SHUTTLE<<2
0x13	SHUTTLE<<3
0x14	SHUTTLE<<4
0x15	SHUTTLE<<5
0x16	SHUTTLE<<6
0x17	SHUTTLE>>0
0x18	SHUTTLE>>1
0x19	SHUTTLE>>2
0x1a	SHUTTLE>>3
0x1b	SHUTTLE>>4
0x1c	SHUTTLE>>5
0x1d	SHUTTLE>>6
0x1e	JOG<
0x1f	JOG>
0x20	CH5
0x21	CH6
0x22	CH7

0x23 CH8
0x24 (reserve)
0x25 (reserve)
0x26 (reserve)
0x27 (reserve)
0x28 (reserve)
0x29 (reserve)
0x2a (reserve)
0x2b (reserve)
0x2c SELECT
0x2d CALL
0x2e ENTER
0x2f (reserve)
0x30 (reserve)
0x31 (reserve)
0x32 (reserve)
0x33 (reserve)
0x34 (reserve)

2-5. Checksum Byte

Checksum is computed as the sum of all previous bytes (including the length byte), then mask with 0x7f.

Appendix A: Remote Control

The remote controller (RC-200, Figure 1) is an accessory to enhance the handy operations of the DVR. You can perform all the settings and operations by the remote controller. The effective distance is up to 10 meters without any obstacle. The keypad functions are same as the front panel key button of the DVR.

There are some replacement keys for JOG and SHUTTLE, definitions are:

JOG ► : Same as turning the JOG clockwise.

JOG ◀ : Same as turning the JOG counter-clockwise.

SHUTTLE ►►

- 1: fast forward 2X or slow forward 1/2X.
- 2: fast forward 4X or slow forward 1/4X.
- 3: fast forward 8X or slow forward 1/8X.
- 4: fast forward 16X or slow forward 1/10X.
- 5: fast forward 32X or slow forward 1/16X.
- 6: fast forward 600X or slow forward 1/32X.

SHUTTLE ◀◀

- 1: fast rewind 2X or slow rewind 1/2X.
- 2: fast rewind 4X or slow rewind 1/4X.
- 3: fast rewind 8X or slow rewind 1/8X.
- 4: fast rewind 16X or slow rewind 1/10X.
- 5: fast rewind 32X or slow rewind 1/16X.
- 6: fast rewind 600X or slow rewind 1/32X.

Note: The channel keys #10~16 are not available.

Reserved only for 16 CH DVR.

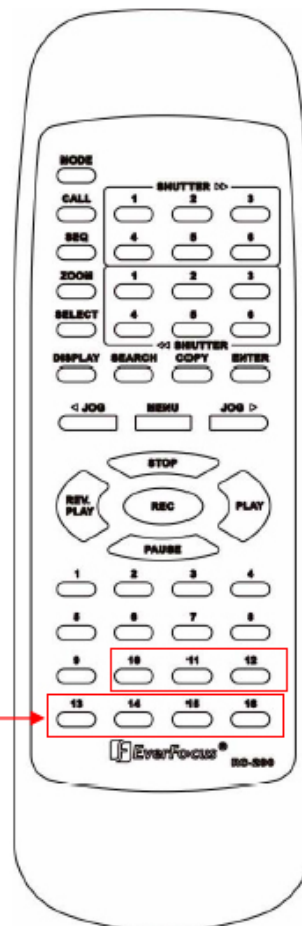

Appendix B: Alarm Board Configuration

Alarm I/O pin assignment

The alarm connector, **Figure 1**, is used to provide one sensor alarm input for each camera input. For easy operation, an alarm extension board, **Figure 2**, is provided to connect to the alarm connector.

Each alarm input requires two wires, one wire connects to the desired alarm input pin, the second wire connects to the ground. The alarm signal assignment is shown as below.

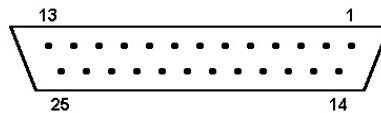

<Figure 1>
D-SUB 25 pin female connector

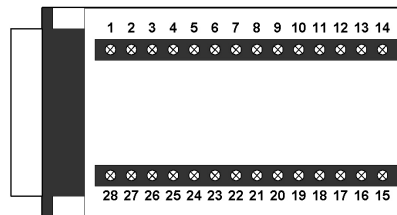

<Figure 2>
PR16D00400 Alarm extension

DVR	
PIN #	NAME
1	GND
2	ALM 1
3	ALM 2
4	ALM 3
5	ALM 4
6	ALM 5
7	ALM 6
8	ALM 7
9	ALM 8
10	-----
11	-----
12	-----
13	-----
14	-----
15	-----
16	-----
17	-----
18	ALMRSTO
19	REC
20	REC-IN
21	DISKFULL
22	-----
23	ALM-N.C
24	ALM-N.O
25	ALM-COM

HOST	
PIN #	NAME
1	GND
2	ALM 1
3	ALM 2
4	ALM 3
5	ALM 4
6	ALM 5
7	ALM 6
8	GDN
9	ALM 7
10	ALM 8
11	-----
12	-----
13	-----
14	-----
15	-----
16	-----
17	-----
18	-----
19	ALMRST
20	REC-IN
21	GND
22	-----
23	DISKFULL
24	-----
25	ALM-N.C
26	ALM-N.O
27	ALM-COM
28	GND

Troubleshooting

If you have difficulty operating your system, run through the following checklist to see if you can solve the problem.

□ **The DVR will not go into record mode?**

Make sure the HDD is locked in with the key. Also check to make sure the hard drive is set to Master. A diagram located on the Hard Drive Label will show you how to set the drive to master.

□ **The DVR displays no picture?**

First you should check if the equipment is connected properly. See Chapter 1 for help.

The second thing to check is if all the wires work properly.

The next step is to verify the recorder and cameras are getting the correct amount of power.

□ **There is no display coming from one of the channels on the DVR?**

The first step is to verify is the problem coming from the recorder or the camera.

Simply take a working camera and plug it into the port that seems to not be working. If you see a picture this means the problem is coming from the camera.

□ **I cannot connect to the recorder via the internet?**

1. Are you using Internet Explorer?
2. Make sure you have downloaded and installed the ActiveX controls. For help with this, see Chapter 14.
3. Are you using the IP address from the Internet Service provider?
4. Does your internet provider block any ports?
5. If you are using a router are the ports in your router opened?
(**NOTE:** Please refer to “Network Setup Menu” section for port settings. For example, HTTP port: 00080, Control port: 01600, Data port: 37260)

EverFocus Electronics Corp.

Head Office:

12F, No.79 Sec. 1 Shin-Tai Wu Road,
Hsi-Chih, Taipei, Taiwan
TEL: +886-2-26982334
FAX: +886-2-26982380
www.everfocus.com.tw

USA Office:

1801 Highland Ave. Unit A
Duarte, CA 91010, U.S.A.
TEL: +1-626-844-8888
FAX: +1-626-844-8838
www.everfocus.com

USA N.Y. Office:

415 Oser Avenue Unit S
Hauppauge, NY 11788
TEL: 631-436-5070
FAX: 631-436-5027
www.everfocus.com

Europe Office:

Albert-Einstein-Strasse 1
D-46446 Emmerich, Germany
TEL: 49-2822-9394-0
www.everfocus.de

China Office:

Room B-05D-1, KESHI PLAZA , Shangdi
Information Industry Base, Haidian District,
Beijing China 100085
TEL: +86-10-62973336/37/38/39
FAX: +86-10-62971423
www.everfocus.com.cn

Japan Office:

1809 WBG MARIBU East 18F,
2-6 Nakase.Mihama-ku.
Chiba city 261-7118, Japan
TEL : +81-43-212-8188
FAX : +81-43-297-0081
www.everfocus.com

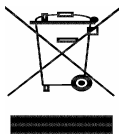

Your EverFocus product is designed and manufactured with high quality materials and components which can be recycled and reused. This symbol means that electrical and electronic equipment, at their end-of-life, should be disposed of separately from your household waste. Please, dispose of this equipment at your local community waste collection/recycling centre. In the European Union there are separate collection systems for used electrical and electronic product. Please, help us to conserve the environment we live in!

Ihr EverFocus Produkt wurde entwickelt und hergestellt mit qualitativ hochwertigen Materialien und Komponenten, die recycelt und wieder verwendet werden können. Dieses Symbol bedeutet, dass elektrische und elektronische Geräte am Ende ihrer Nutzungsdauer vom Hausmüll getrennt entsorgt werden sollen. Bitte entsorgen Sie dieses Gerät bei Ihrer örtlichen kommunalen Sammelstelle oder im Recycling Centre. Helfen Sie uns bitte, die Umwelt zu erhalten, in der wir leben!



EverFocus®

P/N: M41HG0010E _Ver. H