

OMRON

Smart Electrostatic Sensor

ZJ-SD Series

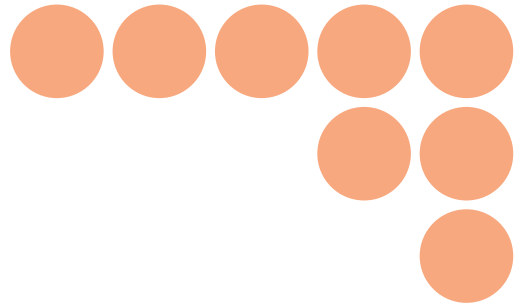

User's Manual



Cat. No. Z237-E1-02

Introduction

Thank you for purchasing the ZJ-SD.

This manual provides information regarding functions, performance and operating methods that are required for using the ZJ-SD.

When using the ZJ-SD, be sure to observe the following:

- The ZJ-SD must be operated by personnel knowledgeable in electrical engineering.
- To ensure correct use, please read this manual thoroughly to deepen your understanding of the product.
- Please keep this manual in a safe place so that it can be referred to whenever necessary.

Introduction	APPLICATION CONSIDERATIONS (Please Read)	Introduction
Section 1	FEATURES	Section 1
Section 2	PREPARATION FOR MEASUREMENT	Section 2
Section 3	BASIC OPERATION	Section 3
Section 4	MAIN APPLICATIONS AND SETTING METHODS	Section 4
Section 5	DETAILED SETTINGS	Section 5
Section 6	AUXILIARY FUNCTIONS	Section 6
Section 7	APPENDICES	Section 7

User's Manual

**Smart Electrostatic Sensor
ZJ-SD Series**

READ AND UNDERSTAND THIS DOCUMENT

Please read and understand this document before using the products. Please consult your OMRON representative if you have any questions or comments.

WARRANTY

OMRON's exclusive warranty is that the products are free from defects in materials and workmanship for a period of one year (or other period if specified) from date of sale by OMRON.

OMRON MAKES NO WARRANTY OR REPRESENTATION, EXPRESS OR IMPLIED, REGARDING NON-INFRINGEMENT, MERCHANTABILITY, OR FITNESS FOR PARTICULAR PURPOSE OF THE PRODUCTS. ANY BUYER OR USER ACKNOWLEDGES THAT THE BUYER OR USER ALONE HAS DETERMINED THAT THE PRODUCTS WILL SUITABLY MEET THE REQUIREMENTS OF THEIR INTENDED USE. OMRON DISCLAIMS ALL OTHER WARRANTIES, EXPRESS OR IMPLIED.

LIMITATIONS OF LIABILITY

OMRON SHALL NOT BE RESPONSIBLE FOR SPECIAL, INDIRECT, OR CONSEQUENTIAL DAMAGES, LOSS OF PROFITS OR COMMERCIAL LOSS IN ANY WAY CONNECTED WITH THE PRODUCTS, WHETHER SUCH CLAIM IS BASED ON CONTRACT, WARRANTY, NEGLIGENCE, OR STRICT LIABILITY.

In no event shall responsibility of OMRON for any act exceed the individual price of the product on which liability is asserted.

IN NO EVENT SHALL OMRON BE RESPONSIBLE FOR WARRANTY, REPAIR, OR OTHER CLAIMS REGARDING THE PRODUCTS UNLESS OMRON'S ANALYSIS CONFIRMS THAT THE PRODUCTS WERE PROPERLY HANDLED, STORED, INSTALLED, AND MAINTAINED AND NOT SUBJECT TO CONTAMINATION, ABUSE, MISUSE, OR INAPPROPRIATE MODIFICATION OR REPAIR.

SUITABILITY FOR USE

THE PRODUCTS CONTAINED IN THIS DOCUMENT ARE NOT SAFETY RATED. THEY ARE NOT DESIGNED OR RATED FOR ENSURING SAFETY OF PERSONS, AND SHOULD NOT BE RELIED UPON AS A SAFETY COMPONENT OR PROTECTIVE DEVICE FOR SUCH PURPOSES.

Please refer to separate catalogs for OMRON's safety rated products.

OMRON shall not be responsible for conformity with any standards, codes, or regulations that apply to the combination of products in the customer's application or use of the product.

At the customer's request, OMRON will provide applicable third party certification documents identifying ratings and limitations of use that apply to the products. This information by itself is not sufficient for a complete determination of the suitability of the products in combination with the end product, machine, system, or other application or use.

The following are some examples of applications for which particular attention must be given. This is not intended to be an exhaustive list of all possible uses of the products, nor is it intended to imply that the uses listed may be suitable for the products:

- Outdoor use, uses involving potential chemical contamination or electrical interference, or conditions or uses not described in this document.
- Nuclear energy control systems, combustion systems, railroad systems, aviation systems, medical equipment, amusement machines, vehicles, safety equipment, and installations subject to separate industry or government regulations.
- Systems, machines, and equipment that could present a risk to life or property.

Please know and observe all prohibitions of use applicable to the products.

NEVER USE THE PRODUCTS FOR AN APPLICATION INVOLVING SERIOUS RISK TO LIFE OR PROPERTY WITHOUT ENSURING THAT THE SYSTEM AS A WHOLE HAS BEEN DESIGNED TO ADDRESS THE RISKS, AND THAT THE OMRON PRODUCT IS PROPERLY RATED AND INSTALLED FOR THE INTENDED USE WITHIN THE OVERALL EQUIPMENT OR SYSTEM.

PERFORMANCE DATA

Performance data given in this document is provided as a guide for the user in determining suitability and does not constitute a warranty. It may represent the result of OMRON's test conditions, and the users must correlate it to actual application requirements. Actual performance is subject to the OMRON Warranty and Limitations of Liability.

CHANGE IN SPECIFICATIONS

Product specifications and accessories may be changed at any time based on improvements and other reasons.

It is our practice to change model numbers when published ratings or features are changed, or when significant construction changes are made. However, some specifications of the product may be changed without any notice. When in doubt, special model numbers may be assigned to fix or establish key specifications for your application on your request. Please consult with your OMRON representative at any time to confirm actual specifications of purchased products.

DIMENSIONS AND WEIGHTS

Dimensions and weights are nominal and are not to be used for manufacturing purposes, even when tolerances are shown.

ERRORS AND OMISSIONS

The information in this document has been carefully checked and is believed to be accurate; however, no responsibility is assumed for clerical, typographical, or proofreading errors, or omissions.

PROGRAMMABLE PRODUCTS

OMRON shall not be responsible for the user's programming of a programmable product, or any consequence thereof.

COPYRIGHT AND COPY PERMISSION

This document shall not be copied for sales or promotions without permission.

This document is protected by copyright and is intended solely for use in conjunction with the product. Please notify us before copying or reproducing this document in any manner, for any other purpose. If copying or transmitting this document to another, please copy or transmit it in its entirety.

Precautions for Safe Use

The following points are important to ensure safety, so make sure that they are strictly observed.

■ Installation Environment

- Do not use the product in environments where it can be exposed to inflammable/explosive gas.
- Do not install the product close to high-voltage devices and power devices in order to secure the safety of operation and maintenance.

■ Power Supply and Wiring

- The supply voltage must be within the rated range.
- Open-collector outputs should not be short-circuited.
- High-voltage lines and power lines must be wired separately from this product. Wiring them together or placing them in the same duct may cause induction, resulting in malfunction or damage.
- Avoid connecting or disconnecting connectors while the product is powered ON. Doing so may damage the product.
- Reverse connection of the power supply and output terminals is not allowed. Connection to an AC power supply is also not allowed.
- Connect a supply voltage and current within the rated ranges to the output terminals.

■ Others

- Do not disassemble, repair, or modify this product.
- This product is not compatible with the ZX series. Do not connect a ZJ-S___ in combination with a ZX series Amplifier Unit.
- Supply power from a UL Class 2 DC power supply or a DC power supply unit that has a countermeasure (safety ultra-low voltage circuit) built-in for preventing high voltages from occurring.
- Be sure to insulate the sensor case as it is connected to the 0 V line of the internal circuits.
- Always ground the 0 V terminal to prevent electrical shock and to enable performing measurements correctly.
- Do not operate this product with wet hands. Doing so might cause a malfunction.
- Do not ground the 24 V terminal. Doing so may cause malfunctions.
- Do not drop this product or subject it to strong shock. Doing so might cause a malfunction.
- Prevent static discharge from being applied to the Sensor Head even if it is operating within the measurement voltage range. Doing so might cause a malfunction.
- Dispose of this product as industrial waste.

Precautions for Correct Use

Observe the following precautions to prevent failure to operate, malfunctions, or undesirable effects on product performance.

■ Installation Site

Do not install the product in locations subjected to the following conditions:

- Ambient temperature outside the rating
- Rapid temperature fluctuations (causing condensation)
- Relative humidity outside the rating
- Presence of corrosive or flammable gases
- Presence of dust, salt, or iron particles
- Direct vibration or shock
- Direct sunlight
- Water, oil, or chemical fumes or spray
- Strong magnetic or electric field

Component Installation and Handling

■ Power Supply and Wiring

- The cables must be 10 m or shorter in total length, for both the sensor and Amplifier Unit. To extend the cable from the Sensor Head, an optional double-ended connector cable (ZX-XC_A) must be used. For extension of the cable of Amplifier Units, shielded cables of the same type must be used.
- When using a commercially available switching regulator, make sure that the FG (Frame Ground) terminal is grounded.
- If surge currents are present in the power lines, connect surge absorbers that suit the operating environment.
- When two or more Amplifier Units are connected by a Calculating unit (ZX-CAL2) for use, connect the linear GND of all Amplifier Units.

■ Warming Up

After turning ON the power supply, allow the product to stand for at least 30 minutes before use. The circuits are still unstable just after the power supply is turned ON, so measured values may fluctuate gradually.

■ Maintenance and Inspection

- Always turn OFF the power supply before adjusting or connecting/disconnecting the Sensor Head.
- Do not use thinner, benzene, acetone or kerosene to clean the Sensor Head and Amplifier Units.
- Do not allow dust to enter the measurement section.

Editor's Note

Page Format

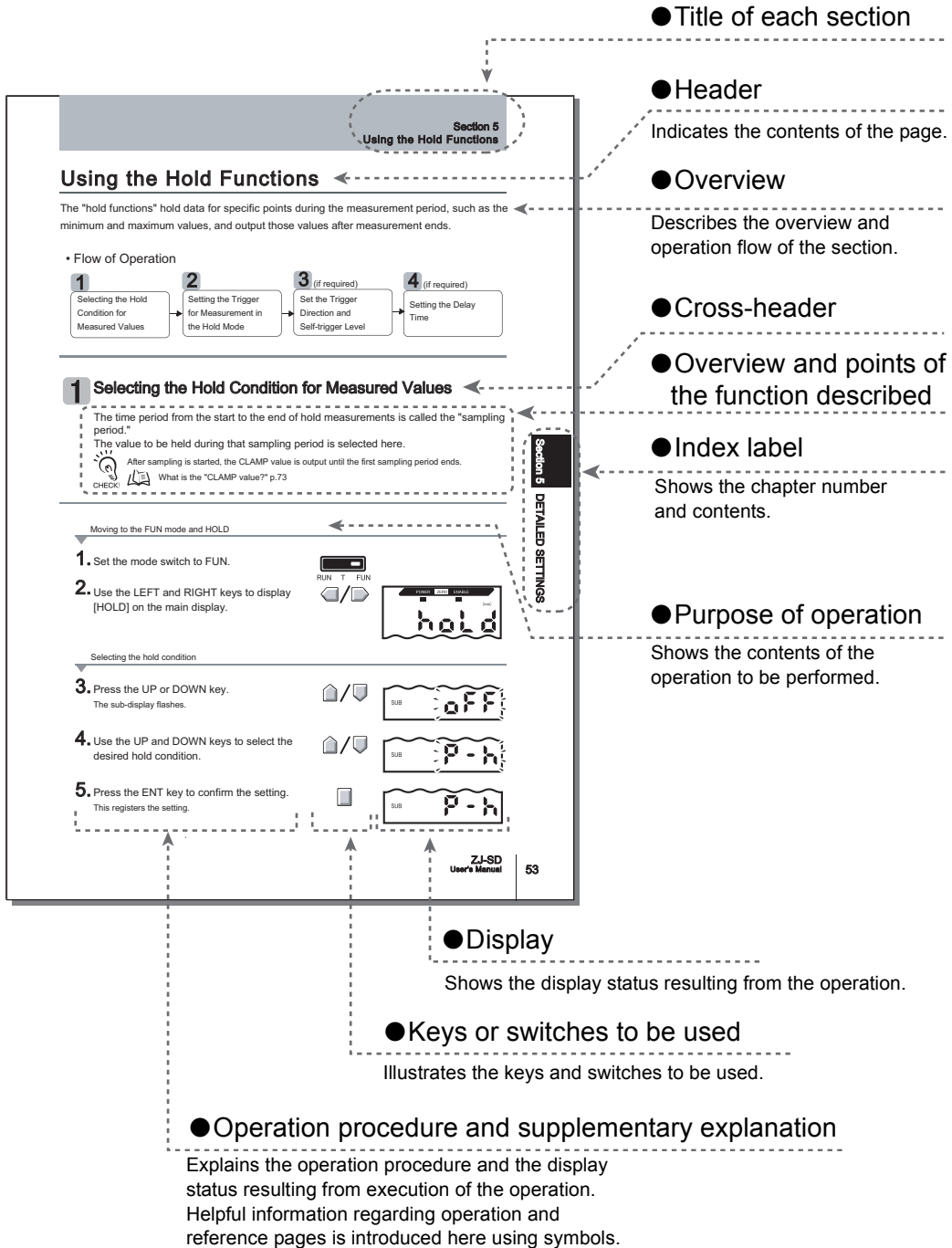

Notational Conventions

■ Menu

In this manual, menu items displayed on the screen are enclosed with [].

■ Operation procedure

Operation steps are numbered to indicate their order.

■ Visual Aids



Indicates points that are important to achieve the full product performance, such as operational precautions and application procedures.



Indicates pages where related information can be found.



Indicates information helpful in operation.

CONTENTS

Precautions for Safe Use	v
Precautions for Correct Use	vi
Editor's Note	vii
CONTENTS	ix

Section 1 FEATURES	1
ZJ-SD Features	2

Section 2 PREPARATION FOR MEASUREMENT	5
Basic Configuration	6
Part Names and Functions	9
Installing the Amplifier Unit	13
Installing Sensor Heads	15
Mounting on the Mounting Bracket	17
Connections	19
Wiring Input/Output Cables	23

Section 3 BASIC OPERATION	25
Flow of Operation	26
Basic Knowledge for Operation	28
Function Transition Charts	33
Correcting the Measurement Reference Voltage	36
Selecting the Measurement Mode	40
Setting the Installation Distance	41

Section 4 MAIN APPLICATIONS AND SETTING METHODS	45
Measuring Sheet Workpieces	46

Section 5 DETAILED SETTINGS	51
Setting the Number of Samples to Average	52
Using the Hold Functions	53
Entering Threshold Values	64
Linear Output	70
Setting Judgment Output Timing (Timer)	79
Setting the Warning Level (Output type)	82
Using the Area Correction Function	85
Selecting Banks	88

Section 6 AUXILIARY FUNCTIONS	91
Changing the Number of Display Digits	92
Reversing the Display	93
Adjusting Display Brightness (ECO Display)	95
Key Lock Function	96
Initializing Setting Data	97
Changing Display Scales	99
Comparing Measured Values (Differentiation Function)	105

Section 7 APPENDICES	109
Troubleshooting	110
Error Messages and Countermeasures	111
Q&A	113
Glossary	114
Specifications and Dimensions	115
Communicating with the Static Electricity Smart Monitor via the Interface Unit	124
Characteristic Data	126
Quick Reference for Displays	127
INDEX	131
Revision History	136

MEMO

Section 1

FEATURES

 ZJ-SD Features

2

ZJ-SD Features

The ZJ-SD is a series of static electricity sensors. The purpose of these sensors is to measure the electric potential of the surface of a workpiece charged with static electricity.
Example: Measurement of the potential of a PCB

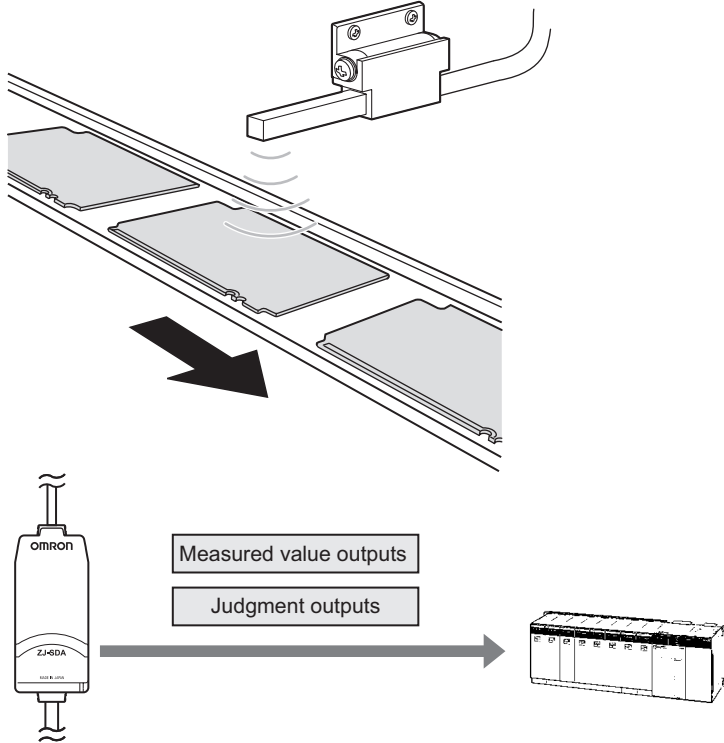

■ High-precision Detection by Distance Correction

The sensor that measures the charged amount of the workpiece is greatly dependent on the distance up to the workpiece.

The ZJ-SD series can be connected to a ZX displacement sensor so that distance correction can be performed on the charged amount using that measurement data and non-uniform workpieces can be measured to high precision.

Also, if the installation distance up to the workpiece is fixed beforehand, distance correction can be performed and highly accurate measurement ensured by directly inputting the distance to the ZJ-SD.

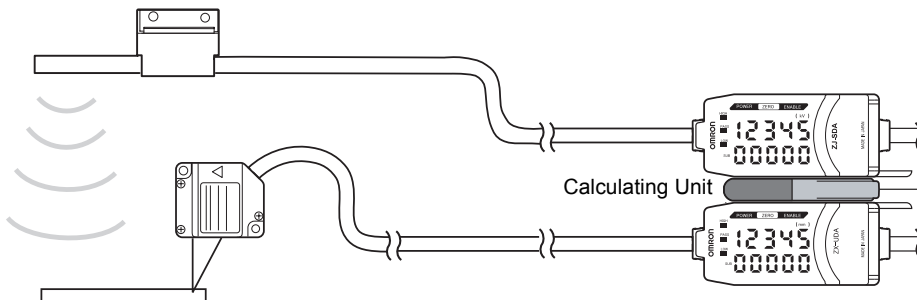

Extendable Sensor Head Cables

Special extension cables are provided to extend the Sensor Heads.

 p.6

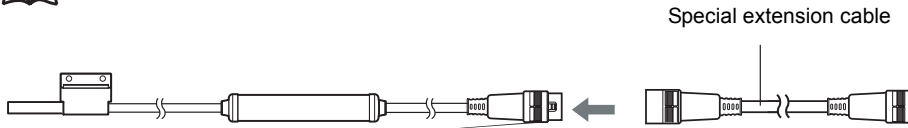

Monitoring Measurement Status

■ Confirm Measurement Status on a Personal Computer

Use an Interface Unit and Static Electricity Smart Monitor to view measurement waveforms and log measurement data on a personal computer. This function is useful for making on-site measurement adjustments and for day-to-day quality control.



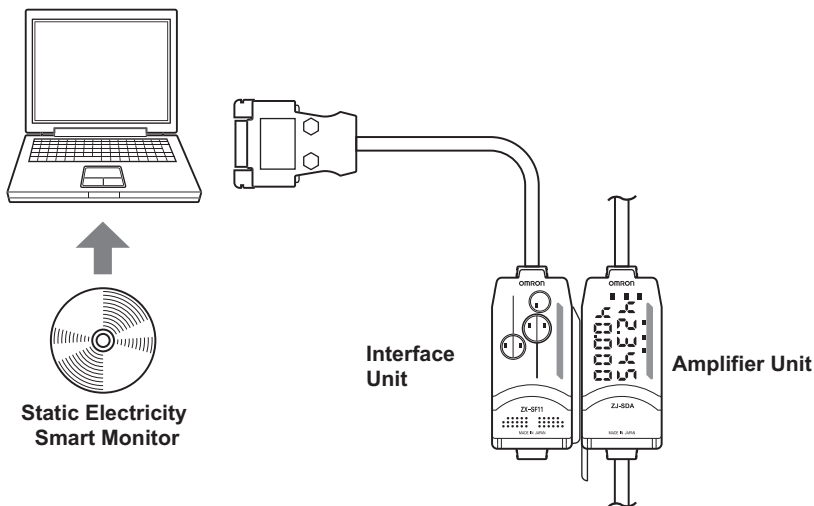



 p.12, p.124



MEMO

Section 2

PREPARATION FOR MEASUREMENT

 Basic Configuration	6
 Part Names and Functions	9
 Installing the Amplifier Unit	13
 Installing Sensor Heads	15
 Mounting on the Mounting Bracket	17
 Connections	19
 Wiring Input/Output Cables	23

Basic Configuration

The basic configuration of the ZJ-SD series of static electricity sensors is shown below.



Use the Sensor Unit and Amplifier Unit in the pre-determined combinations. ZJ-SD Sensor Units and Amplifier Units cannot be used in combination with ZX series Sensor Units and Amplifier Units.

CHECK!

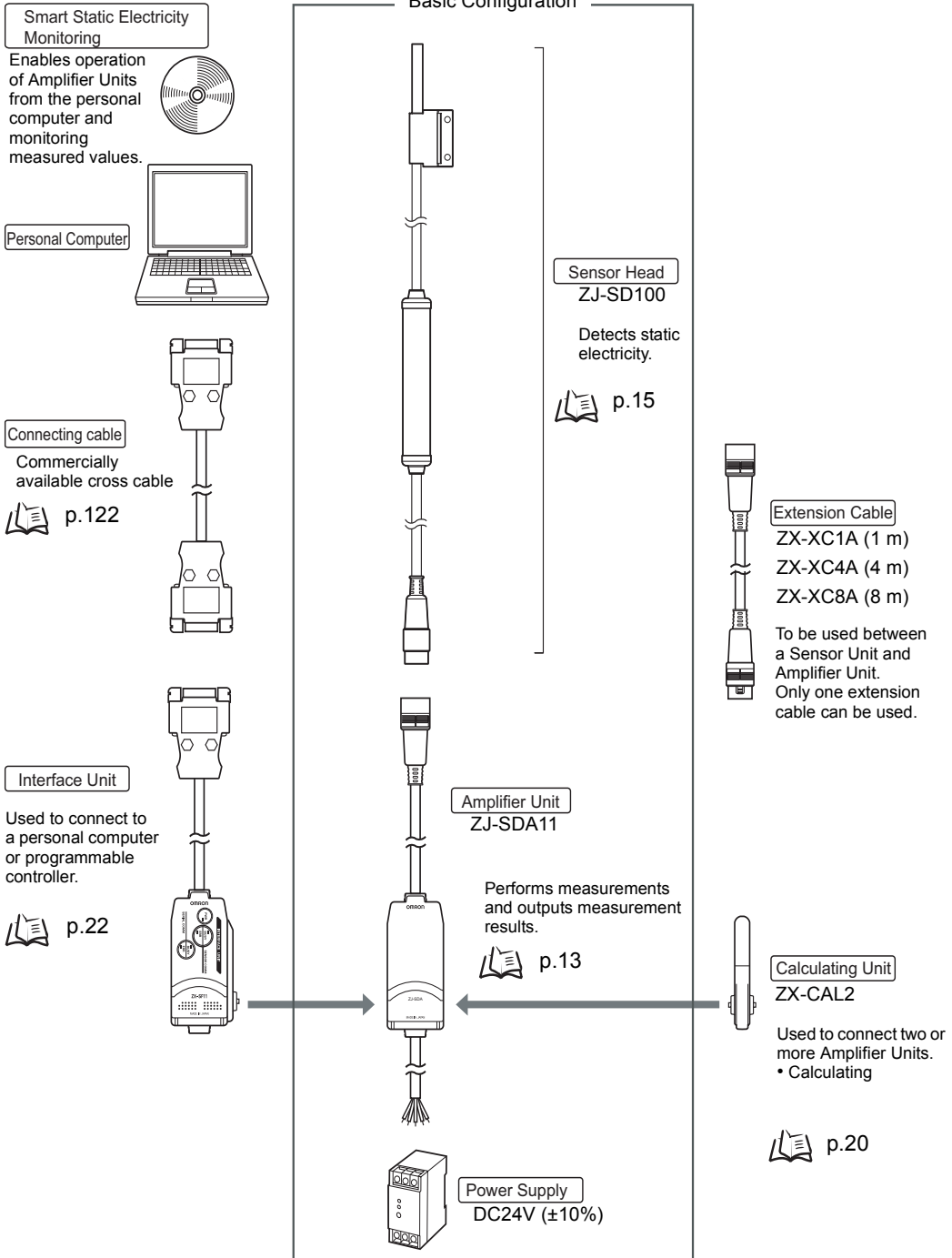

When used in combination with a displacement sensor

The following shows an example of correcting distance using an ultrasonic type displacement sensor.

■ When a personal computer (and Amplifier Unit) are not included in the basic configuration

Example 1)

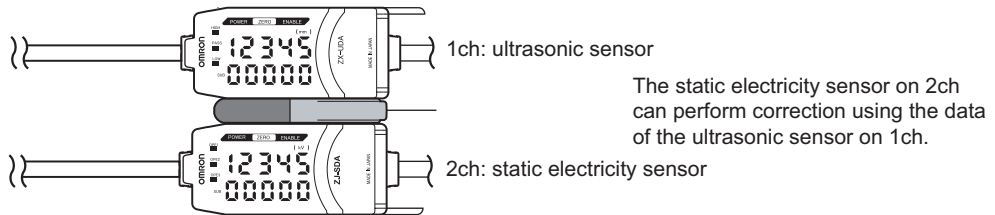

Example 2)

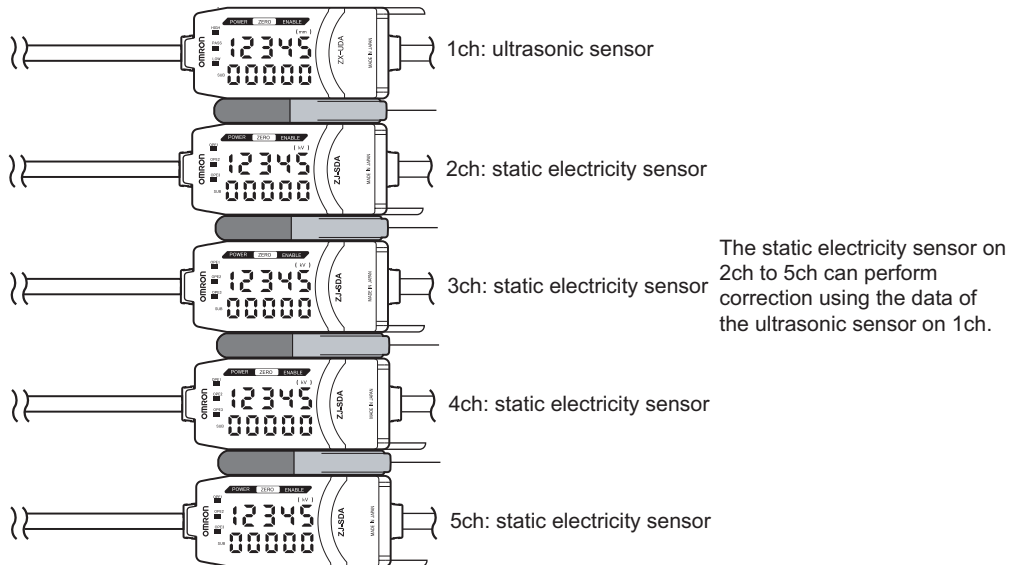

■ When a personal computer (and Amplifier Unit) are included in the basic configuration

The [Reference destination setting] can be set in the Static Electricity Smart Monitor.

Example 1)

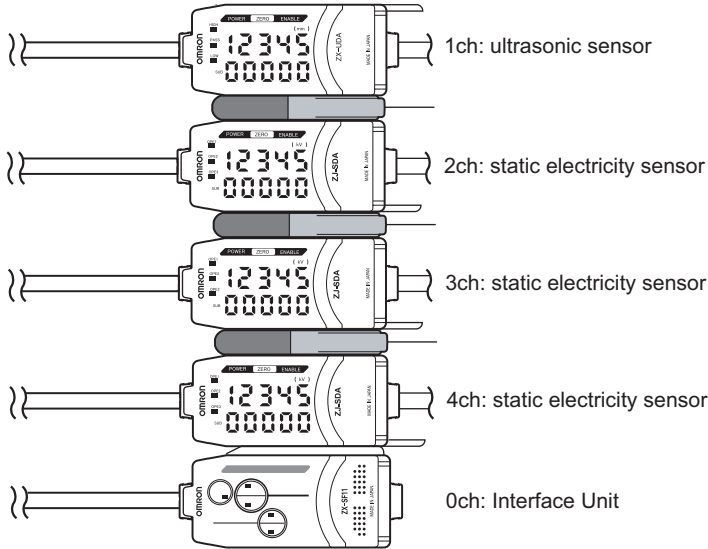

(When [Reference destination setting] is set to [CH1]), the static electricity sensor on 2ch to 4ch can perform correction using the data of the ultrasonic sensor on 1ch.

Example 2)

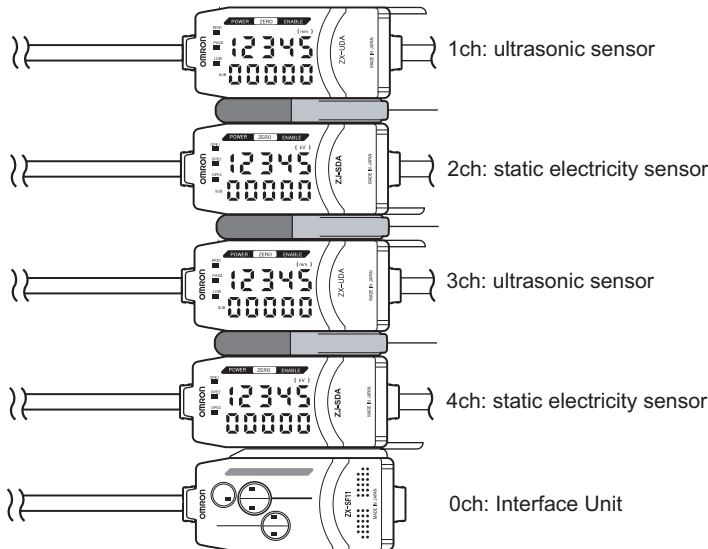

*(When [Reference destination setting] is set to [Next CH]), the static electricity sensor on 2ch and 4ch can perform correction using the data of the ultrasonic sensors on 1ch and 3ch, respectively.

*4ch cannot reference 1ch and 2ch cannot reference 3ch.

Part Names and Functions

Amplifier Unit

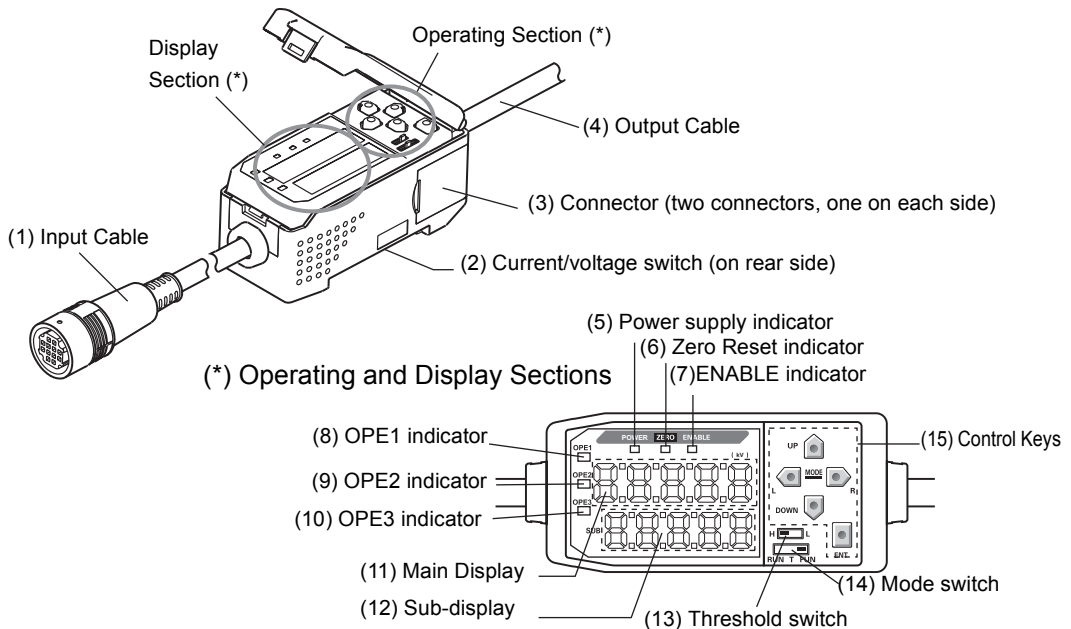

- (1) The input cable connects the Sensor Head.
- (2) The current/voltage switch selects either current output or voltage output.

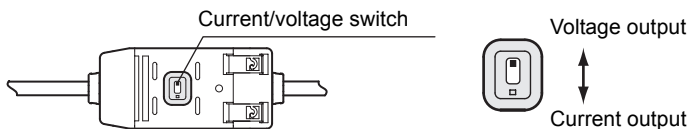

Monitor focus must also be set when switching the output. p.70

- (3) The connectors connect the Calculating and Interface Units.
- (4) The output cable connects the sensor to the power supply and external devices, such as sync sensors or programmable controllers.
- (5) The power indicator lights when the Sensor is powered ON.
- (6) The Zero Reset indicator lights when the zero reset function is enabled.
- (7) The ENABLE indicator lights when the sensor is ready for measurement. It goes off when measurement is not possible (e.g. when the measuring range is exceeded, or when the Sensor Head is not connected when the power is turned ON).
- (8) The OPE1 indicator lights according to the judgment result or warning state. p.10
- (9) The OPE2 indicator lights according to the judgment result or warning state. p.10
- (10) The OPE3 indicator lights according to the judgment result or warning state. p.10
- (11) The main display shows measured values and function names.
- (12) The sub-display shows additional information and function setting values for measurements. Reading Displays p.29
- (13) The threshold switch selects whether to set (and display) the HIGH or LOW threshold.
- (14) The mode switch selects the operating mode. Switching Modes p.28
- (15) The Control Keys set measurement conditions and make other settings. Key Operations p.30

Judgment results/warning states and indicators

Hold	Output type	OPE1	OPE2	OPE3
Other than peak and bottom hold	Standard	HIGH	PASS	LOW
	Warning	WARN	OK	NG
Peak and bottom hold	Warning/standard	WARN	Peak-OK	Bottm-OK

OK: ON when PASS

NG: ON whether other than PASS (HIGH or LOW)

WARN: ON in warning state

Peak-OK: ON when the peak hold result is OK (PASS)

Bottm-OK: ON when the bottom hold result is OK (PASS)



CHECK!

The warning state continues until one of "Reset input ON", "Switch to FUN mode" and "Power OFF" is executed.

Sensor Head

■ Sensor Head

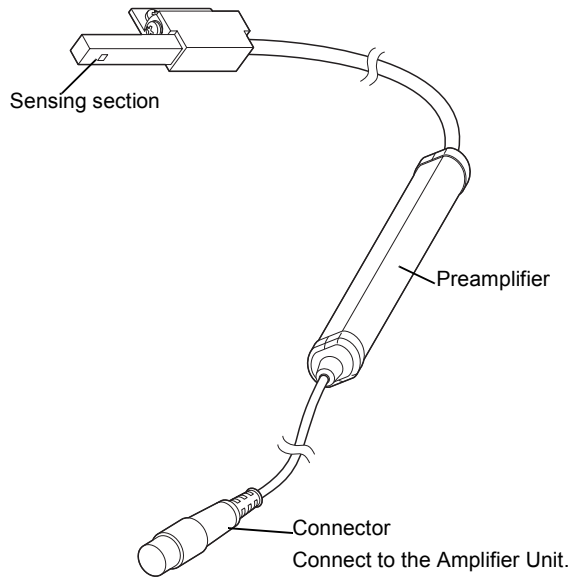

Calculating Unit

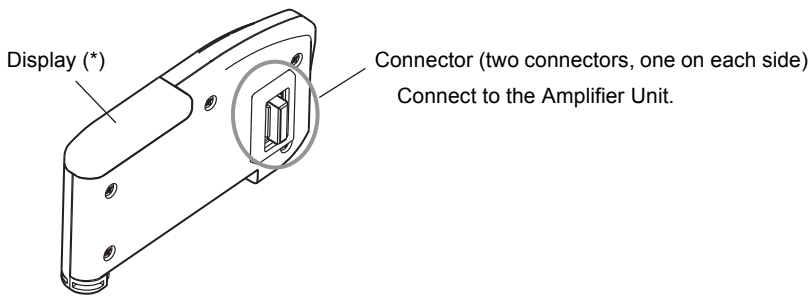

* Display

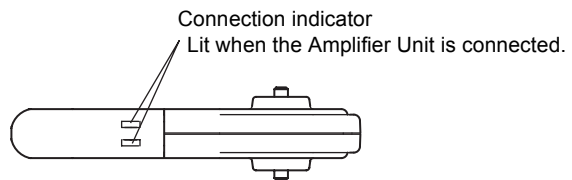

Interface Unit

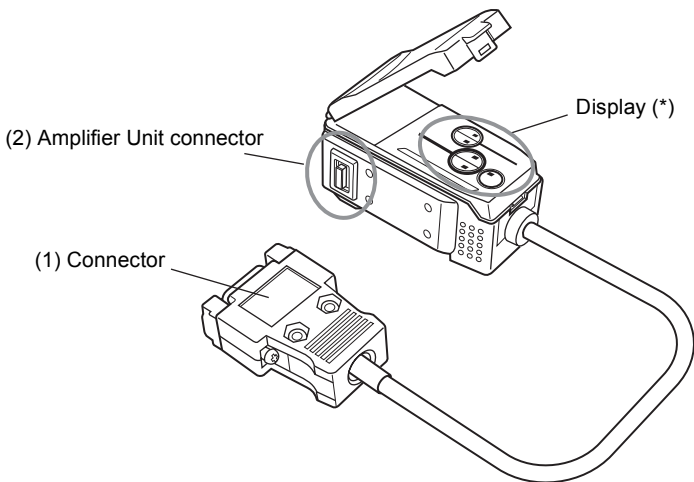

* Display

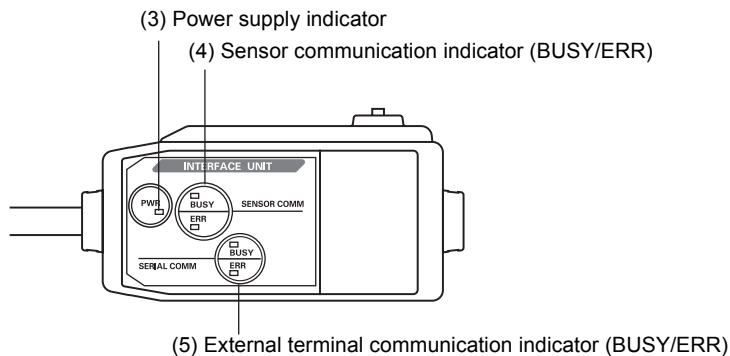

- (1) The communications connector connects the communications cable to the computer.
- (2) The Amplifier Unit connector connects to the Amplifier Unit.
- (3) The power supply indicator lights while the power is supplied.
- (4) BUSY : Lights during communications with the Smart Sensor.
ERR : Lights if an error occurs during communications with the Smart Sensor.
- (5) BUSY : Lights during communications with the personal computer.
ERR : Lights if an error occurs during communications with the personal computer.

Installing the Amplifier Unit

Amplifier Units can be easily mounted onto the 35-mm DIN Track.

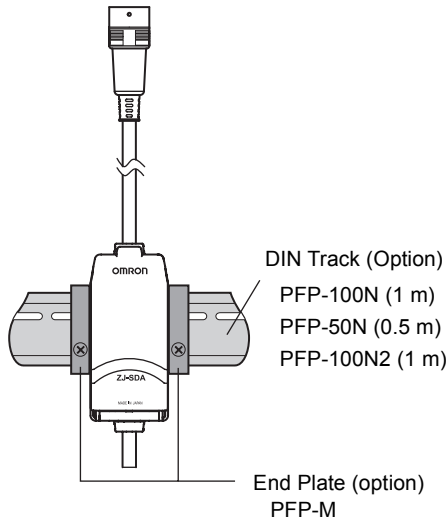

■ Installation

Hook the connector end of the Amplifier Unit on the DIN Track and press in at the bottom until the Unit locks into place.

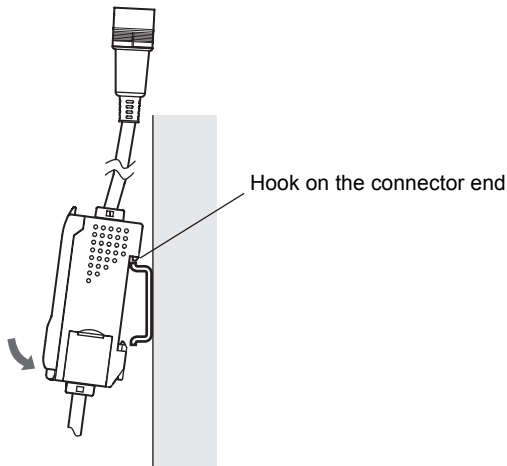

Always hook the connector end of the Amplifier Unit on the DIN Track first. The mounting strength may decrease if the output cable end is hooked on the DIN Track first.

CHECK!

■ Removal Method

Push the Amplifier Unit up and pull out from the connector end.

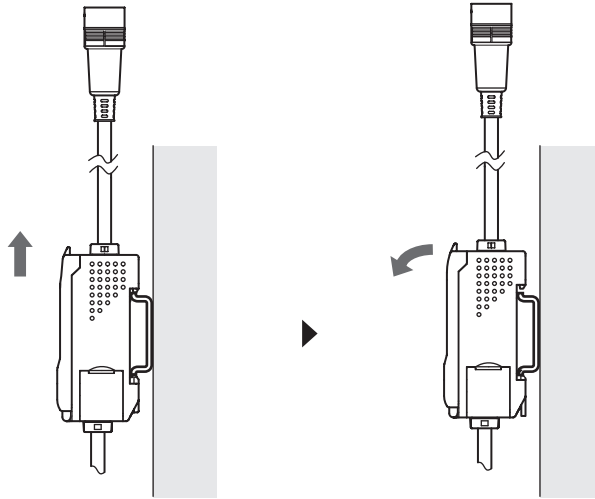

■ Using the Product in Conformance with CE

To use this product in conformance with CE, install the enclosed ferrite core as shown below.

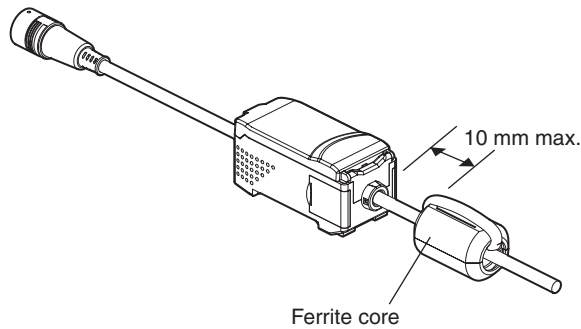

Installing Sensor Heads

This section describes how to install Sensor Heads.

Sensor Head

■ Installation

1. Fix the Sensor Head using screws.

The screws must be tightened with a torque of 0.5 Nm or less.

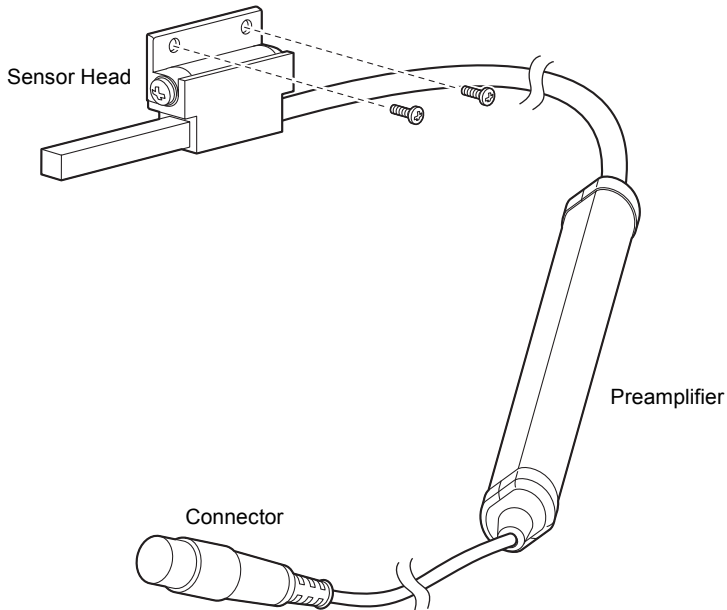

- Mount the Sensor Head in a stable location with little vibration.
- When this sensor is used and installed in combination with a distance sensor, we recommend using the exclusive mounting bracket (ZJ-XBU1).

- Do not allow anything to touch the metal case of the Sensor Head. Failure to do so might prevent accurate measurement by the sensor.



Setting the Installation Distance p.41, Scaling p.99

2. Adjust the angle of the Sensor Head.

Loosen the two screws on the sides of the holder, and adjust the angle of the Sensor Head so that it faces the object to be measured.



- Do not remove the screws.

3. Tighten the screws on the sides of the holder to set the angle.

Firmly tighten both screws to a maximum torque of 0.5 N·m.

Preamplifier

■ Installation

1. Use M3 screws to fix the enclosed Preamplifier mounting bracket.

Use the ZX-XBT2 Preamplifier DIN Track Mounting Bracket (order separately) when mounting the Preamplifier onto a DIN Track.

2. Fit one end of the Preamplifier into the bracket.

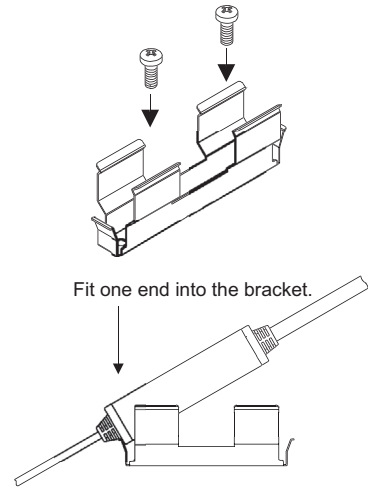

3. Fit the other end of the Preamplifier into the bracket.

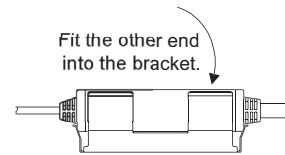

CHECK!

To remove the Preamplifier from the mounting bracket, lift upwards while holding the center of the Preamplifier.

[Removal]

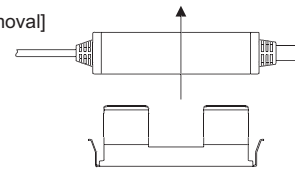

Lift while holding the center.

■ Using the Product in Conformance with CE

To use this product in conformance with CE, loop the cable twice around the enclosed ferrite core as shown below.

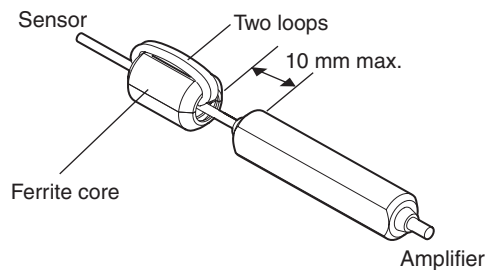

Mounting on the Mounting Bracket

The following describes how to mount the laser type Smart Sensor (ZX-LD) and static electricity sensor (ZJ-S), or ultrasonic type Smart Sensor (ZX-UD) and static electricity sensor (ZJ-S) onto the exclusive mounting bracket (ZJ-XBU1).

 Setting the Installation Distance p.41

■ Installation

■ Example of mounting the ZX-LD

1. Fix the ZX-LD onto the mounting bracket (ZJ-XBU1) using M3 screws.

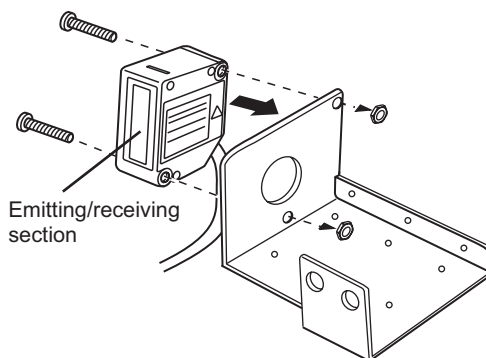

The screws must be tightened with a torque of 0.3 Nm or less.

Take care not to touch the emitting/receiving section of the Sensor Head. Adhesion of finger marks may prevent correct measurements. If you have touched them, wipe them with a clean, soft cloth.

2. Fix the ZJ-S using the screws.

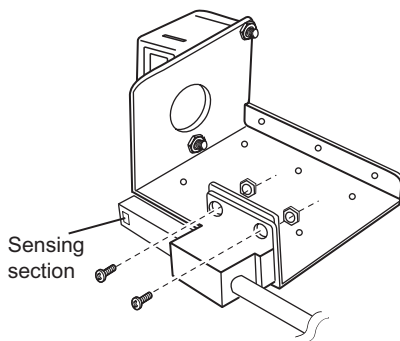

Do not allow anything to touch the metal case of the Sensor Head. Failure to do so might prevent accurate measurement by the sensor.

Section 2 Mounting on the Mounting Bracket

■ Example of mounting the ZX-UD__

1. Fix the ZX-UD__ onto the mounting bracket (ZJ-XBU1) using the M18 tightening nut.

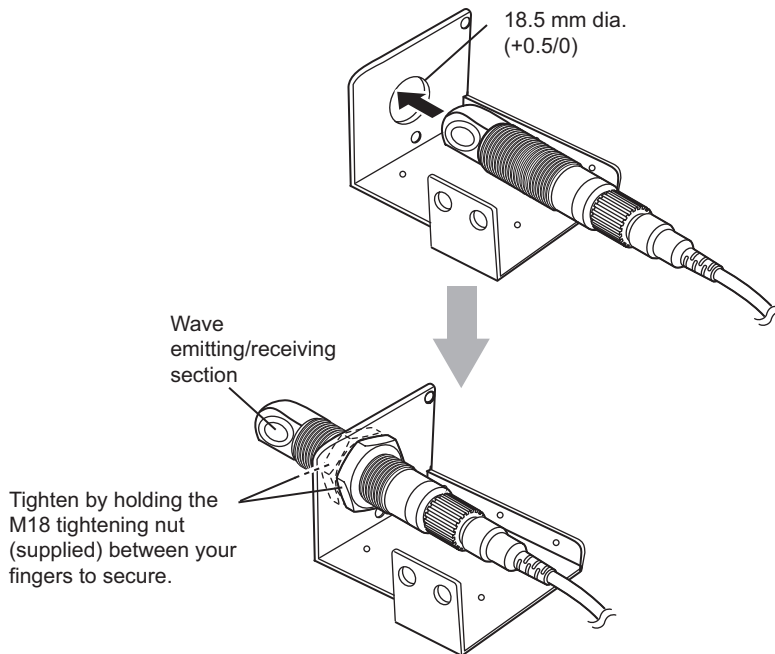

The nut must be tightened with a torque of 45 Nm or less.

2. Fix the ZJ-S__ using the screws.

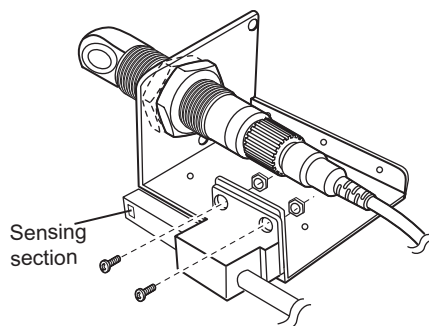

Do not allow anything to touch the metal case of the Sensor Head. Failure to do so might prevent accurate measurement by the sensor.

Connections

This section describes how to connect component parts of the Smart Sensor.



Before connecting/disconnecting Smart Sensor components, make sure that the power to the Amplifier Unit is turned OFF. The Smart Sensor may malfunction if components are connected or removed while the power is ON.

Sensor Head



Do not touch the terminals inside the connector.

■ Connecting the Sensor Head

Push the Sensor Head connector into the Amplifier Unit connector until it locks.

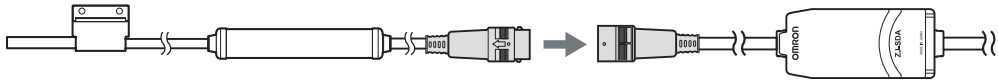

■ Disconnecting the Sensor Head

To disconnect the Sensor Head, hold the Sensor Head's connector ring and the Amplifier Unit connector, and then pull them straight out.



- Be sure to hold the connector of the Amplifier Unit to disconnect it. Failure to do so may damage the input cable of the Amplifier Unit.
- Do not touch the terminals inside the connector.

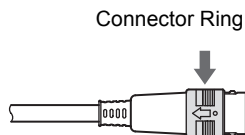

All settings on the Amplifier Unit will be cleared if the Sensor Head is replaced with a different type.

Calculating Unit

Use a Calculating Unit to connect Amplifier Units when performing communications with two or more Amplifier Units.

Up to five Amplifier Units can be connected.



Provide power to all connected Amplifier Units.

CHECK!

■ Connection Method

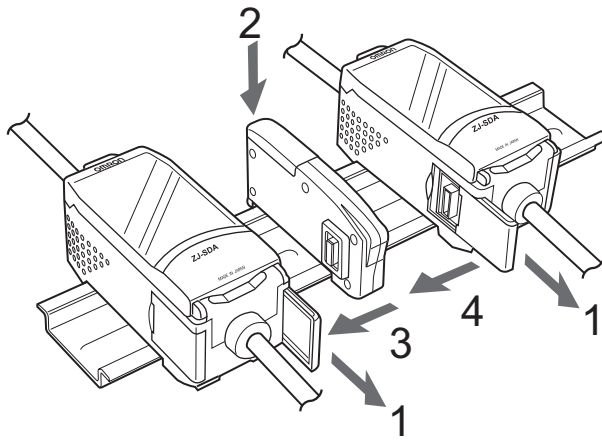

- 1.** Open the connector cover on the Amplifier Unit.
Open the connector cover by lifting and sliding it open.
- 2.** Mount the Calculating Unit onto the DIN Track.
- 3.** Slide and connect the Calculating Unit to the Amplifier Unit connector.
- 4.** Slide and connect the second Amplifier Unit to the Calculating Unit connector.

To disconnect the Calculating Unit, perform the above operations in reverse order.

■ Channel Numbers of Amplifier Units

The following diagram shows the channel numbers when two or more Amplifier Units are connected.

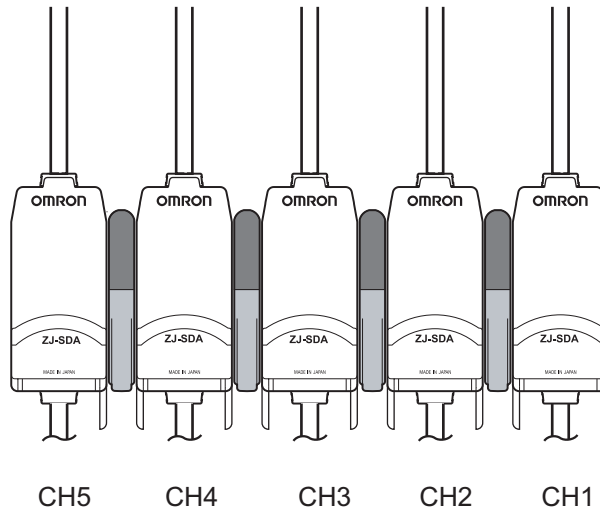

Interface Unit

Use an Interface Unit to connect a personal computer to the Smart Sensor system.

■ Connection Method

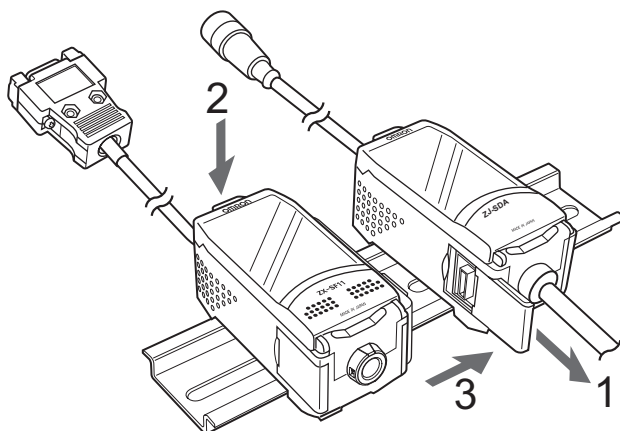

- 1.** Open the connector cover on the Amplifier Unit.
Open the connector cover by lifting and sliding it open.
- 2.** Mount the Interface Unit onto the DIN Track.
- 3.** Slide and connect the Interface Unit to the Amplifier Unit connector.

To disconnect the Interface Unit, perform the above operations in reverse order.



CHECK!

- When two or more Amplifier Units are used, connect the Interface Unit to the Amplifier Unit with the highest channel number.
- Communication with the static electricity Smart Monitor is possible via the Interface Unit.



p.124

Wiring Input/Output Cables

The input/output cable has the following wires.



Wire the cable correctly. Incorrect wiring may damage the Smart Sensor.

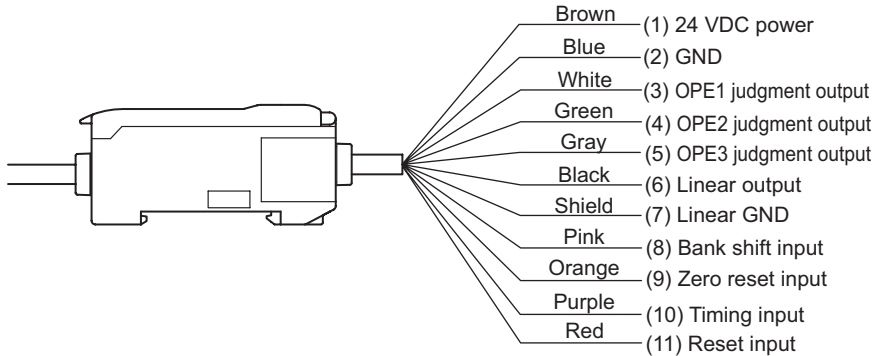

(1) 24 VDC ($\pm 10\%$) power supply is connected to the power supply terminal.



Use a stabilized power supply separate from other devices and power systems for the Amplifier Unit, when high resolution is required.

(2) The GND terminal is the 0 V power supply terminal. This terminal becomes the common terminal for inputs/outputs other than linear output.



The 0 V terminal must be grounded in order for measurements to be performed correctly.

(3) The OPE1 indicator lights according to the judgment result or warning state. p.10

(4) The OPE2 indicator lights according to the judgment result or warning state. p.10

(5) The OPE3 indicator lights according to the judgment result or warning state. p.10

(6) The linear output outputs a current or voltage in accordance with the measurement result.

(7) The linear output GND terminal is the 0 V terminal for the linear output.



- This ground wire must be grounded separately from the other ground wires.
- Always ground the linear output terminal even when linear output is not used.
- When using Calculating Units, make sure that the linear GND lines of the Amplifier Units are connected to each other.

(8) When this input is ON: The bank is switched using (9), (10), and (11). p.88

(9) (8)=ON: Bank switching is executed. p.88

(8)=OFF: The zero reset input is used to execute and clear zero reset. p.37

(10) The timing input is for signal input from external devices.

(8)=ON: The bank is specified. p.88

(8)=OFF: Use it for hold function timing. The sub-display indicates [TIMNG] while the hold function timing is input. p.56

(11)(8)=ON: The bank is specified. p.88

(8)=OFF: The reset input resets all measurement processing and outputs. The sub-display indicates [RESET] while the hold function reset is input. The linear and judgment output signals are output according to the non-measurement settings. If this reset input switches ON while the hold function is used, the state that was active before the hold function was set is restored. p.77

I/O Circuit Diagrams

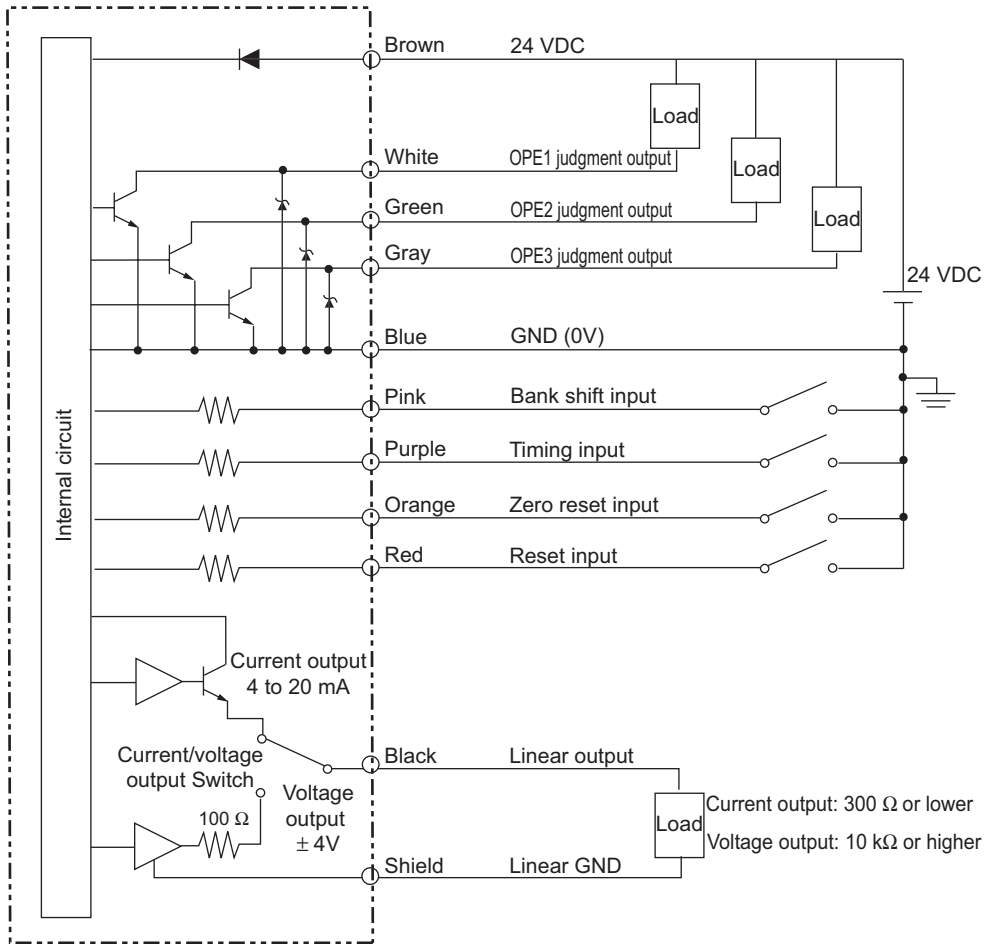







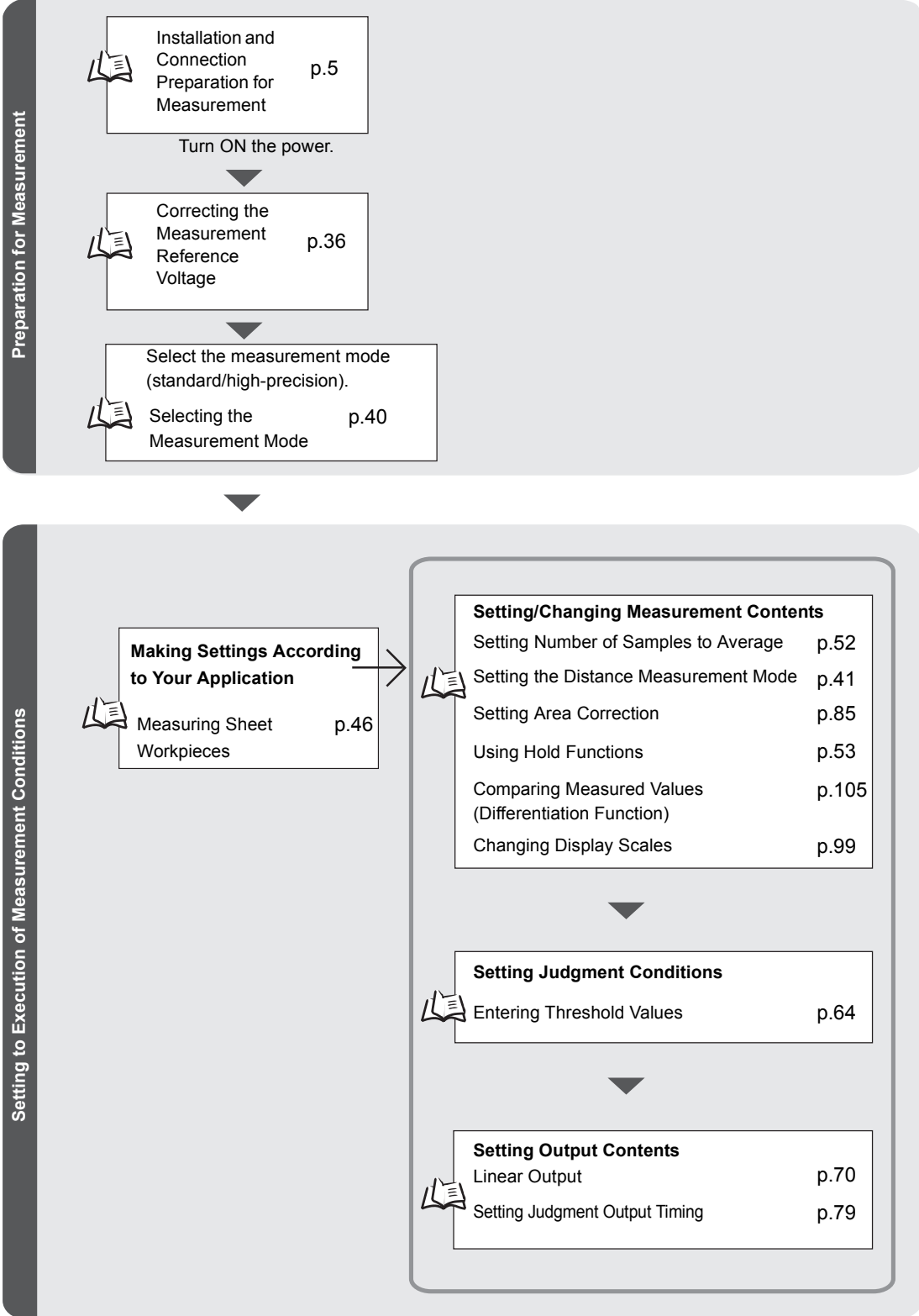

Section 3

BASIC OPERATION





☒	Flow of Operation	26
☒	Basic Knowledge for Operation	28
☒	Function Transition Charts	33
☒	Correcting the Measurement Reference Voltage	36
☒	Selecting the Measurement Mode	40
☒	Setting the Installation Distance	41

Flow of Operation





<p>When a Problem Occurs....</p> <p> The Smart Sensor Does Not Operate Correctly  Troubleshooting p.110</p>	<p> An Error Message Has Appeared  Error Messages and Countermeasures p.111</p>
<p> Want to Know Meanings of Terms  Glossary p.114</p>	<p> Want to Find Contents from Digital Displays  Quick Reference for Displays p.127</p>

Applied Use of Functions

<p> Saving the Zero Reset Level for the Reference Voltage in Zero Reset Memory p.38</p>
<p> Changing the Number of Display Digits p.92</p>
<p> Setting the Warning Level p.82</p>
<p> Switching Banks p.88</p>

Additional Functions

<p> Using the Power-Saving Mode p.95</p>
<p> Reversing the Display during a Zero Reset p.93</p>
<p> Key Lock Function p.96</p>

Changing/Deleting Settings

<p> Initializing Setting Data p.97</p>
--

Basic Knowledge for Operation

Switching Modes

The ZJ-SDA has three modes. Use the Mode Switch on the Amplifier Unit to switch between modes.

Switch to the desired mode before starting operation.

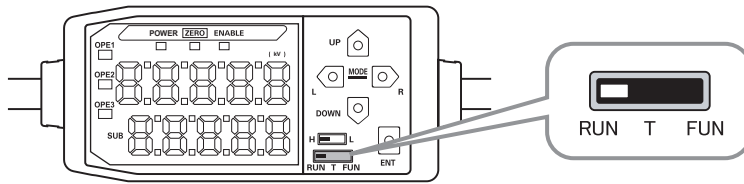

Mode	Description
RUN	Normal operation mode
T	Mode for setting the threshold values
FUN	Mode for setting measurement conditions



Function Transition Charts p.33

Reading Displays



The data displayed on the main and sub-displays depends on the currently selected mode. The sensor is already set to the RUN mode before it was shipped from the factory.

When the power is turned ON, the model of the Amplifier Unit is displayed on the main display followed by the number of channels.

The software version is on the sub-display.

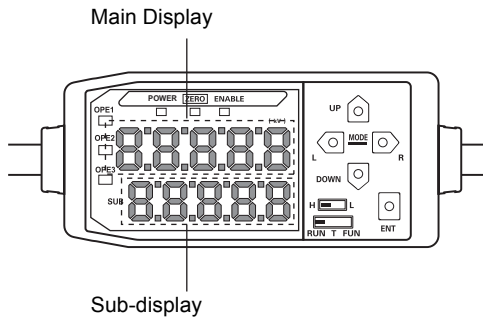
This information is displayed for approx. three seconds, followed by the data for each mode.



Mode	Main display	Sub-display
RUN	Displays the measured value (the value after the measurement conditions have been reflected). For example, when the hold function is set, the held value is displayed.	Displays the threshold value, voltage, current, resolution, distance and present value in order when the Control Keys are pressed. Threshold Value Display Displays either the HIGH or LOW threshold value, depending on the position of the threshold switch. H  L
T	Displays the measured value (the value after the measurement conditions have been reflected). For example, when the hold function is set, the held value is displayed.	Displays the threshold value for the threshold that is being set. Displays either the HIGH or LOW threshold value, depending on the position of the threshold switch. H  L
FUN	Displays the function names in order when the Control Keys are pressed.	Displays the setting value for the function displayed on the main display.

 Function Transition Charts p.33

■ Alphabet Display Format

Alphabet characters appear on the main and sub-displays as shown in the following table.

A	B	C	D	E	F	G	H	I	J	K	L	M
Α	β	γ	δ	Ε	Ϝ	Γ	h	i	υ	ϕ	λ	μ
N	O	P	Q	R	S	T	U	V	W	X	Y	Z
η	ο	ρ	ϑ	ρ	ς	τ	υ	υ	ϕ	υ	ϕ	ζ

■ Key Operations

Use the Control Keys to change the display and set measurement conditions.

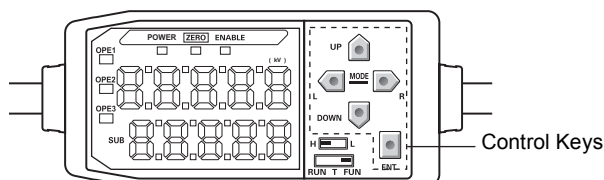

The currently selected mode determines the key functions.

Switching Modes p.28

Key	Function		
	RUN mode	T mode	FUN mode
Cursor Keys LEFT Key RIGHT Key UP Key DOWN Key	Changes the sub-display content.	Used when selecting the numeric value digit	The function changes depending on the setting: <ul style="list-style-type: none"> • Switches the function display. • Selects the numeric value digit. • Stops setting.
	Performs timing input.	Used when changing numeric values	The function changes depending on the setting: <ul style="list-style-type: none"> • Switches between selections. • Changes numeric values.
	Resets input.		
ENT Key	When held down for one second: Performs a zero reset. When held down together with the Right key for three seconds: Cancels the zero reset.	The function changes depending on the operation: <ul style="list-style-type: none"> • Confirms the threshold value. • Executes teaching. 	Confirms the set condition or numeric value.

Condition Settings

Display the target function on the main display and select the desired setting value from the sub-display to set measurement conditions.

This section describes how to set measurement conditions, using an example of setting a peak hold as the hold condition.

Moving to FUN mode and HOLD

1. Set the mode switch to FUN.



2. Use the LEFT and RIGHT keys to display [HOLD] on the main display.

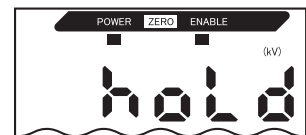

Setting Hold Conditions

3. Press the UP or DOWN key.
The sub-display flashes.



4. Use the UP and DOWN keys to select [P-H].



Press either the LEFT or RIGHT key to cancel the selected option.



The display returns to the current setting ([OFF] in this example).

5. Press the ENT key to confirm the settings.
This registers the setting.



Inputting Numeric Values

This section describes how to input numeric values for threshold and output settings. This section describes how to input directly, using an example of inputting the low threshold.

Changing the low threshold from "40.000" to "39.000"

Moving to the T mode

1. Set the mode switch to T.



Setting threshold values

2. Set the switch to L.

The measured value is displayed on the main display.
The current setting value is displayed on the sub-display.

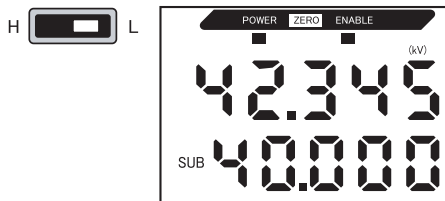

3. Press any cursor key.

The first digit on the sub-display flashes to indicate that direct input is enabled.



4. Use the UP and DOWN keys to display "3".



5. Use the LEFT or RIGHT key to move the cursor to the one's digit.



6. Use the UP and DOWN keys to display "9".

To cancel the selected setting, use the LEFT key to move the cursor to the leftmost digit and press the LEFT key again. Alternatively, use the RIGHT key to move to the rightmost digit and press the RIGHT key again. The display will return to the current setting ("40.000" in this example).



7. Press the ENT key to confirm the settings.

The display stops flashing and stays lit, and the setting is registered.

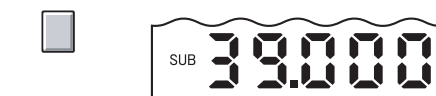

Function Transition Charts

Reading Transition Charts

The upper section is the main display and the lower section is the sub-display.

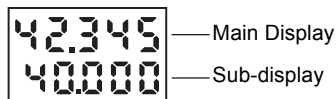

RUN Mode

Measured value*1 (The main display always shows the measured value.)

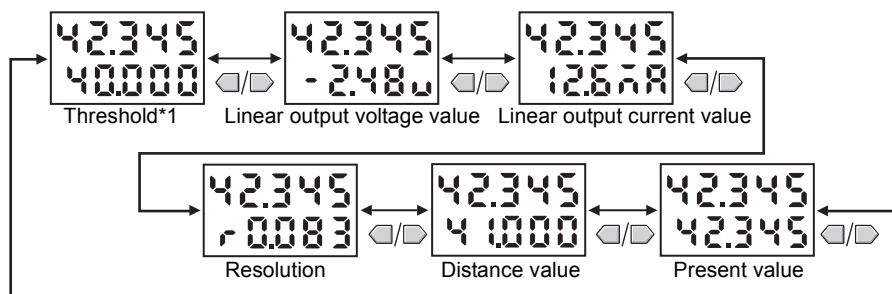

*1 When the mode is switched to RUN, the measured and threshold values are displayed first.

The settings shown in the above diagram are only an example. The actual display may be different.

What is the "present value"? p.114

T Mode

There is no function transition in the T mode.

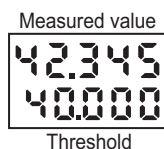

p.64

The setting shown in the above diagram is only an example. The actual display may be different.

In the RUN and T modes, the position of the threshold switch determines whether the HIGH or LOW threshold is displayed.

CHECK!

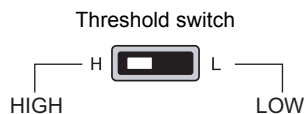

FUN Mode

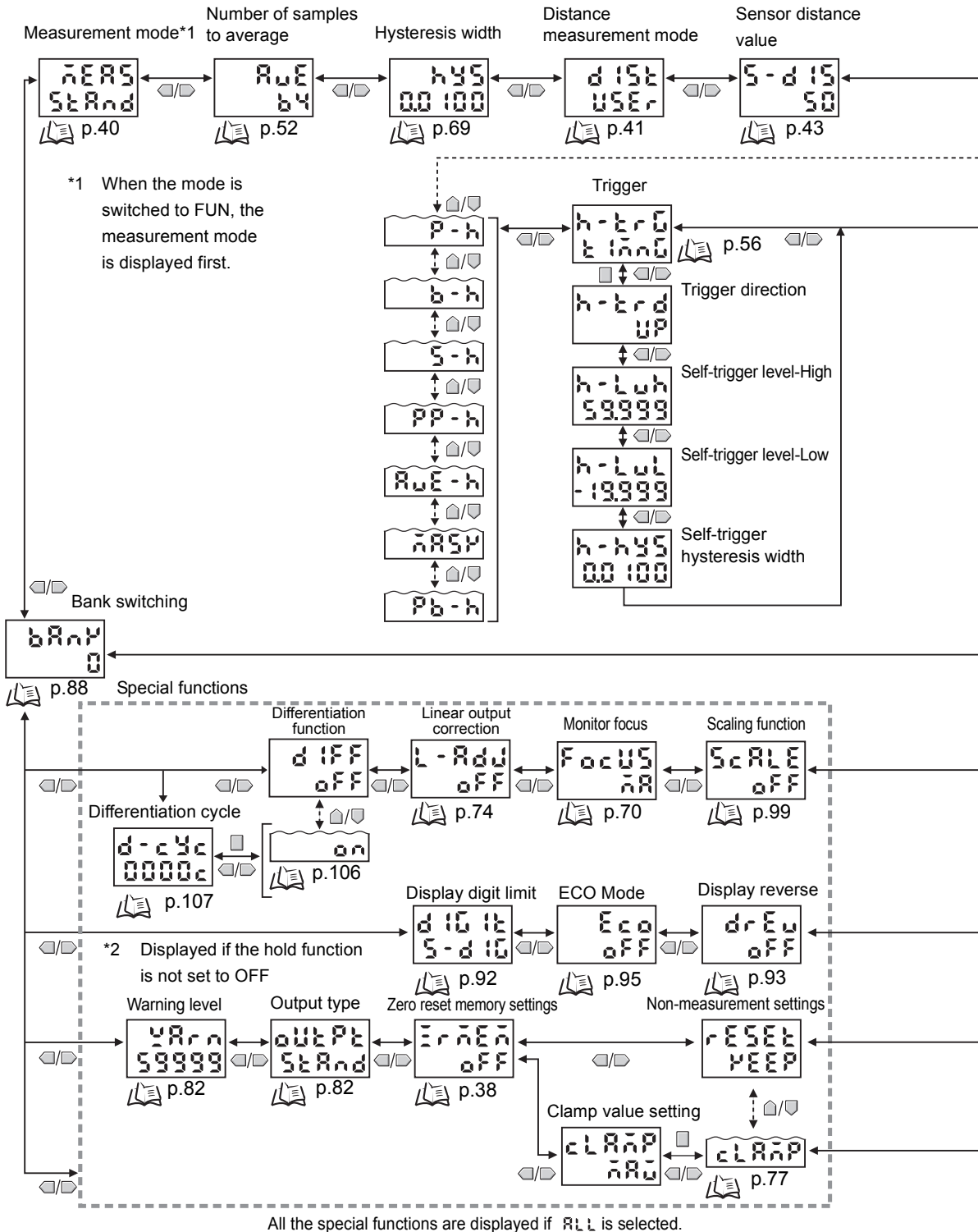

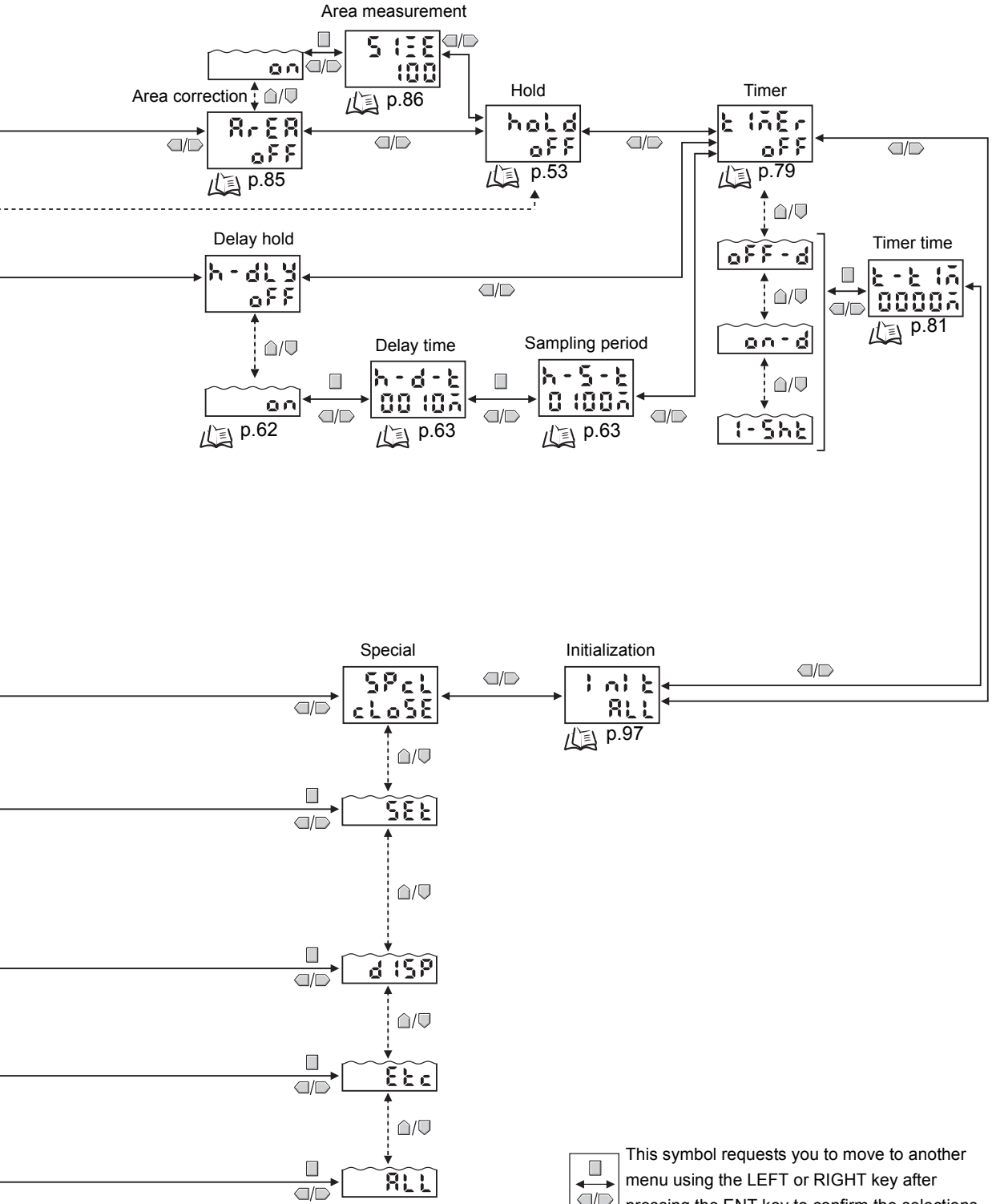

 This symbol requests you to move to another menu using the LEFT or RIGHT key after pressing the ENT key to confirm the selections.

Correcting the Measurement Reference Voltage

More accurate measurement results can be obtained by correcting the potential used as a reference in taking measurements (i.e., resetting zero).

As shown below, zero is reset by using a recommended reference detection object that is grounded.

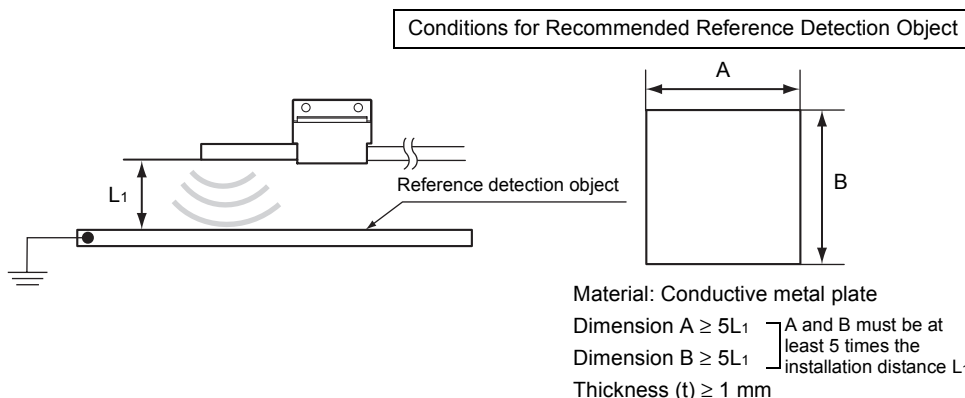

CHECK!

- Accurate measurements may not be possible if the object being used as the reference detection body carries a static charge because there is a charged object nearby or because the plate is not grounded properly.
- The same measurement results can be obtained with a jig or other object as long as the conditions given for the reference detection object are met.

■ Linearity (Reference Values)

The linearity shown in the following graph can be obtained by resetting zero as described above.

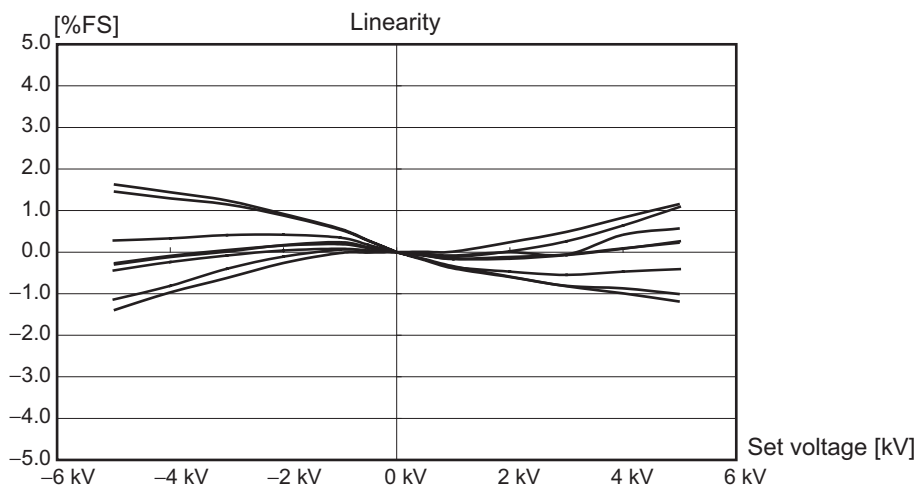

Resetting Zero

The measurement value is used as a reference value to reset zero when a key operation is performed or an external signal is input.

If the reference voltage was previously corrected, the previous correction will be overwritten. With the default setting, the correction value will be saved in memory even when the power supply is turned OFF. The setting can be changed so that the correction value is not saved.

 Saving the Zero Reset Level for the Reference Voltage in Zero Reset Memory p.38

1. Place the reference sensing object in position.

2. Set the mode switch to RUN.



3. Press the ENT key at least one second or input the zero reset signal from an external device (for 800 ms max.).

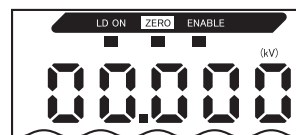

This registers the reference value, and the zero reset indicator lights.

The tolerance for the registered reference value is displayed on the main display.

Clearing the Reference Voltage Correction Value

1. Set the mode switch to RUN.



2. Hold the ENT and RIGHT keys down together for at least three seconds.



To cancel zero reset from an external device, input the zero reset signal for at least one second.



Zero reset is canceled and the zero reset indicator turns OFF.

Saving the Zero Reset Level for the Reference Voltage in Zero Reset Memory

A setting can be changed to specify whether the zero reset level is saved or cleared when the power supply is turned OFF.

Setting	Description
ON (default)	The zero reset level is saved when the power supply is turned OFF.
OFF	The zero reset level is cleared when the power supply is turned OFF.



CHECK!

- Turn ON the zero reset memory to save the zero reset level and use it again when power is turned back ON.
If zero reset memory is turned ON, the zero reset level will be written to EEPROM in the Amplifier Unit every time zero is reset. The write life of the EEPROM is 100,000 writes. If the zero reset level is written every time measurements are taken, malfunction may occur. Manage the write life when turning ON zero reset memory during operation.
- Even if the zero reset memory is turned OFF, the zero reset level will be saved whenever threshold values or other function settings are changed. In this case, the zero reset level will not be cleared the next time the power supply is turned ON.

Moving to the FUN mode and SPCL

1. Set the mode switch to FUN.



2. Use the LEFT and RIGHT keys to display [SPCL] on the main display.



Moving to ZRMEM

3. Press the UP or DOWN key.
The sub-display flashes.



4. Use the UP and DOWN keys to display [ETC] or [ALL].



5. Press the ENT key.



6. Use the LEFT and RIGHT keys to display [ZRMEM] on the main display.

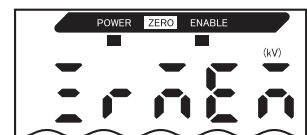

Selecting whether or not to enable zero reset memory

7. Press the UP or DOWN key.
The sub-display flashes.



8. Select either [ON] or [OFF].
ON: Zero reset memory enabled
OFF: Zero reset memory disabled (default)



9. Press the ENT key to confirm the setting.
This registers the setting.



Selecting the Measurement Mode

The ZJ-SD has two measurement modes, the standard mode and the high-precision mode.

Mode	Selection	Measurement distance range	Maximum measurement voltage	Display resolution
Standard mode	STAND	5 to 100 mm	±50 kV	10 V
High-precision mode	HI-AC		±5 kV	1 V



Select the measurement mode before implementing the distance correction function.

CHECK!



Distance correction function p.41

Moving to the FUN mode

1. Set the mode switch to FUN.



2. Use the LEFT and RIGHT keys to display [MEAS] on the main display.

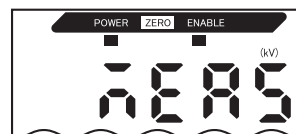

Setting the measurement mode

3. Press the UP or DOWN key.
The sub-display flashes.



4. Select [STAND] or [HI-AC].
STAND: Standard mode
HI-AC: High-precision mode



5. Press the ENT key to confirm the settings.
This sets the selected mode.



Setting the Installation Distance

Set the distance between the static electricity sensor and the workpiece.

The electric potential value can be corrected according to the change in the distance between the workpiece and the Sensor Head by performing measurement in combination with a displacement sensor. The mode to be selected changes according to conditions, such as changes in the distance between the workpiece and the Sensor Head, or use of the exclusive mounting bracket.

Mode	Display	Description
USER mode	USER	When measurement is performed with the distance between the workpiece and the Sensor Head fixed (used on static electricity sensor)
AUTO mode	AUTO	When the exclusive jig is not used when the distance between the workpiece and the Sensor Head changes (when the static electricity sensor and distance sensor are fixed by the user's own jig)
FIX mode	FIX	When the exclusive mounting bracket (ZJ-XBU1) is used to install a laser type Smart Sensor (ZX-LD) or ultrasonic type Smart Sensor (ZX-UD) when the distance between the workpiece and the Sensor Head changes

Mode selection criteria

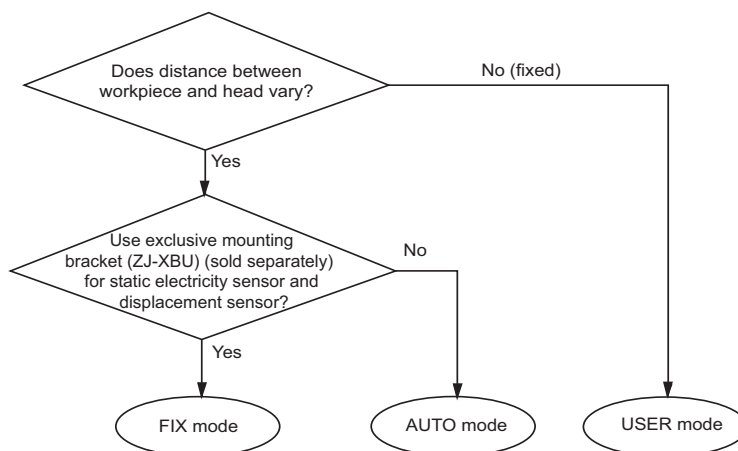

USER mode

Enter the current distance "d" (fixed) between the workpiece and the Sensor Head. If "d" changes, enter the sensor distance value again.

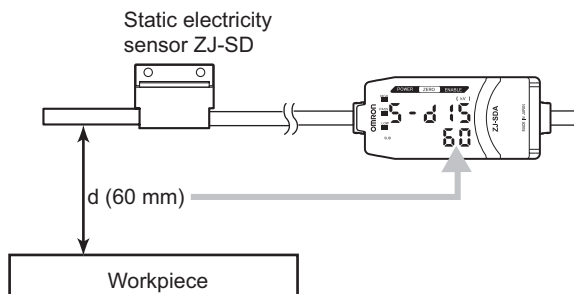

■ **AUTO mode**

Enter the current distance "d" between the workpiece and the Sensor Head.

Enter the sensor distance value again when the relationship between the static electric sensor and the displacement sensor changes.

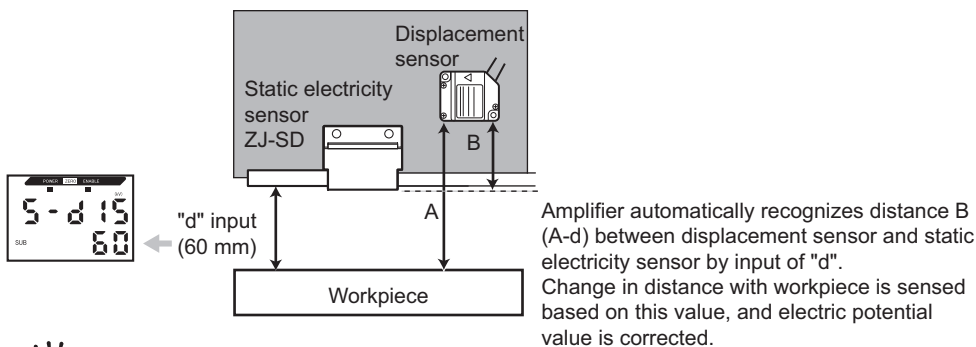

Corrected electric potential value is displayed on amplifier according to distance correction coefficient held by ZJ-S sensor.

CHECK!

■ **FIX mode**

Fix the static electricity sensor (ZJ-SD) and the laser sensor (ZX-LD__) or static electricity sensor (ZJ-SD) and the ultrasonic sensor (ZX-UD__) to the exclusive mounting bracket (ZJ-XBU1). Simply setting the FIX mode frees you from the need to input the distance value.

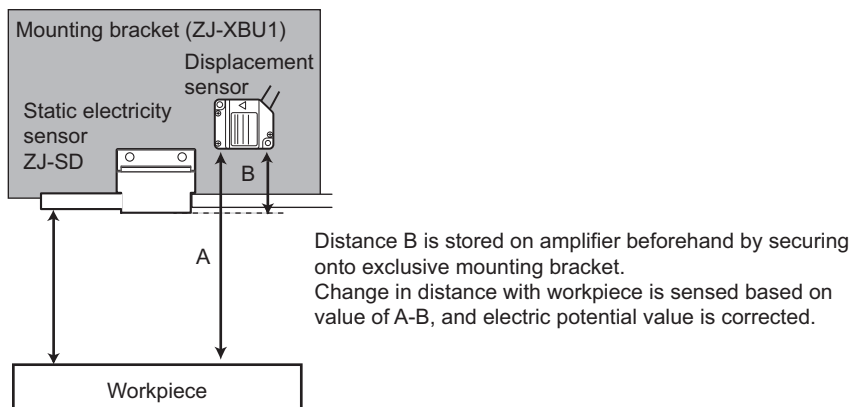

Corrected electric potential value is displayed on amplifier according to distance correction coefficient held by ZJ-S sensor.

CHECK!

Moving to FUN Mode and DIST

1. Set the mode switch to FUN.



2. Use the LEFT and RIGHT keys to display [DIST] on the main display.

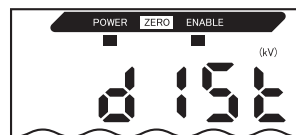

Setting the Distance Measurement Mode

3. Press the UP or DOWN key.
The sub-display flashes.



4. Select the distance correction method.



5. Press the ENT key to confirm the settings.
This sets the selected mode.



Setting the sensor distance value (when [USER] or [AUTO] is selected in the distance measurement mode)

6. Use the LEFT and RIGHT keys to display [S-DIS] on the main display.
In the case of [AUTO]/[FIX]: The distance values currently recognized by the static electric sensor are displayed.

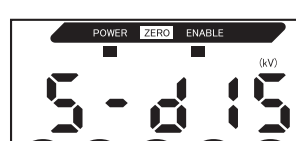

CHECK!

In the FIX mode, the sensor distance values need not be entered.

7. Press the UP or DOWN key.
The leftmost digit of the sub-display flashes.



8. Measure the sensor distance value.



--- Moves from one digit to another.



--- Changes the numeric value.

9. Press the ENT key to confirm the settings.
This registers the specified distance.



MEMO

Section 4

MAIN APPLICATIONS AND SETTING METHODS

 Measuring Sheet Workpieces

46

Measuring Sheet Workpieces

This section describes how to measure the electric potential of the surface of a workpiece, using a PCB as an example.

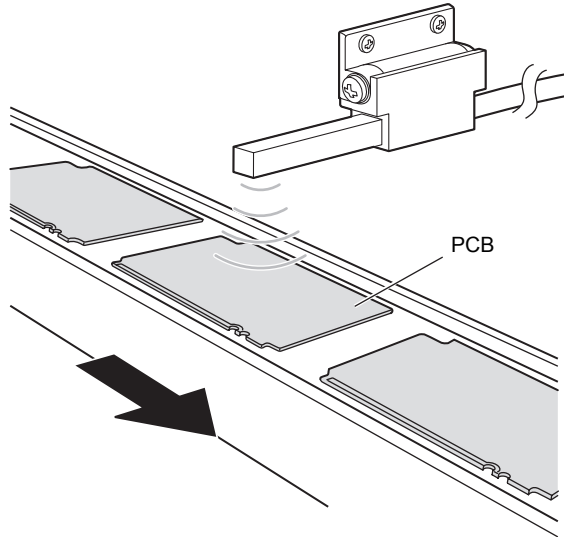

■ Flow of Operation

Place an actual sensing object in position. Have a reference sample ready beforehand.

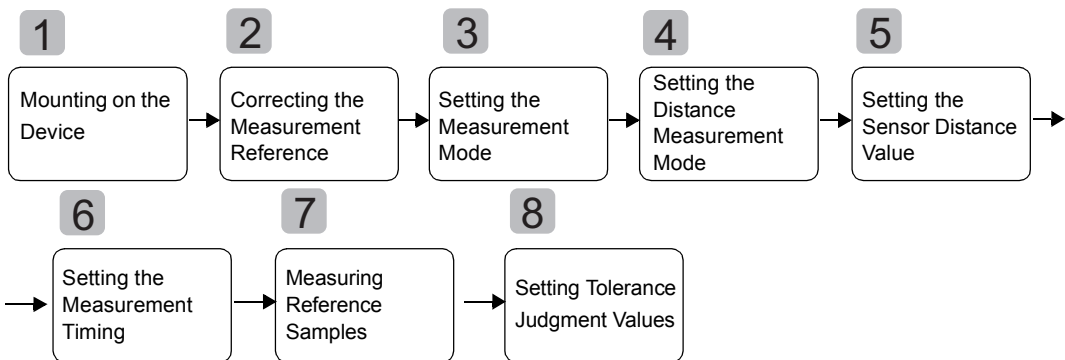

1 Mounting on the Device

Mount the Sensor Head on the inspection device.

When mounting the sensor, take care not to exert pressure on the Sensor Head and wires.



Installing Sensor Heads p.15

2 Correcting the Measurement Reference Voltage

Correct the electric potential that becomes the reference for measuring static electricity.



Correcting the Measurement Reference Voltage p.36

3 Setting the Measurement Mode

Select either the standard mode or high-precision mode.



Selecting the Measurement Mode p.40

4 Setting the Distance Measurement Mode

Select one of the USER, AUTO and FIX modes.



CHECK!

If the distance between the workpiece and the sensor is fixed, select the USER mode. If the distance varies, select the AUTO mode. If the distance varies and the exclusive mounting bracket (ZJ-XBU1) is used for securing the sensor, select the FIX mode.



Setting the Installation Distance p.41

5 Setting the Sensor Distance Value

Set the distance values of the workpiece and sensor.

- In the USER mode, the distance values are fixed by the specified distance.
- In the AUTO mode, the positional relationship between the displacement sensor and the ZJ-SD sensor is registered using preset distances so that distance correction using the displacement sensor is possible.



In the FIX mode, the sensor distance values need not be entered.

CHECK!



Setting the sensor distance value (when [USER] or [AUTO] is selected in the distance measurement mode) p.43

6 Setting Measurement Timing

Use the bottom hold function to hold the minimum value (bottom) during the sampling period.



If the timing cannot be entered from the device, select [DIST] at "Hold trigger" so that sampling can be performed matched to the distance values measured by the distance sensor.

CHECK!

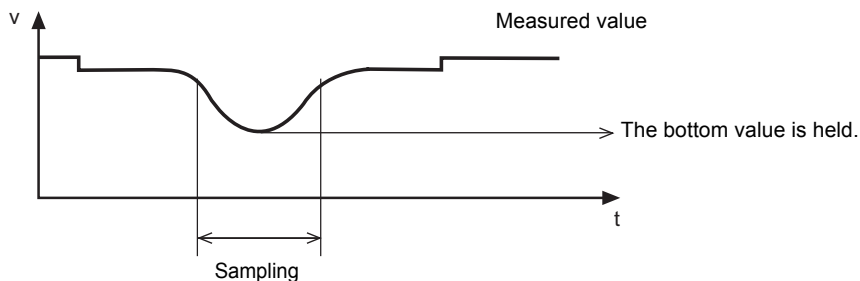

Refer to "Section 5 DETAILED SETTINGS" for details on settings.



Using the Hold Functions p.53

7 Measuring Reference Samples

The difference in the electric potential with the reference sample is measured using position teaching and the measurement result is registered as the HIGH threshold value.

The registered value becomes the reference for the threshold value set in step **6** .

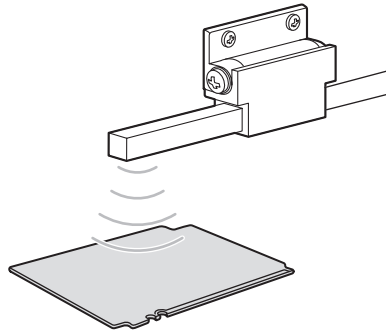

Refer to "Section 5 DETAILED SETTINGS" for details on settings.

 Position Teaching p.66

8 Setting Tolerance Judgment Values

Refer to the HIGH threshold registered in step **6** and set the upper and lower limits (HIGH and LOW thresholds) for a PASS (OK) judgment.

The judgment result will be output based on the threshold value set here.

Output type = standard: "HIGH" "PASS" "LOW"

Output type = warning: "WARN" "OK" "NG"

Measurement result	Judgment result
Measurement result > HIGH threshold	HIGH
LOW threshold ≤ Measurement result ≤ HIGH threshold	PASS
LOW threshold > Measurement result	LOW
Measurement result > warning level (*)	WARN
LOW threshold ≤ measurement result ≤ HIGH threshold	OK
Measurement result > HIGH threshold Or LOW threshold > Measurement result	NG

(*)The level is judged by absolute values as plus and minus warning levels exist.



Setting the Warning Level (Output type) p.82

Refer to "Section 5 DETAILED SETTINGS" for details on operation.



Inputting Threshold Values Directly p.65

Section 5

DETAILED SETTINGS

☒	Setting the Number of Samples to Average	52
☒	Using the Hold Functions	53
☒	Entering Threshold Values	64
☒	Linear Output	70
☒	Setting Judgment Output Timing (Timer)	79
☒	Setting the Warning Level (Output type)	82
☒	Using the Area Correction Function	85
☒	Selecting Banks	88

Setting the Number of Samples to Average

The average of the measured values obtained based on the preset number of samples can be output. This setting can be used when you want to ignore rapid changes in measured values. Note, however, that if this setting is made, the response time for judgment and linear outputs drops.

Selection for No. of samples to average	Response time
1	2 ms
2	3 ms
4	5 ms
8	9 ms
16	17 ms
32	33 ms
64	65 ms
128	129 ms
256	257 ms
512	513 ms
1024	1025 ms

In the case of the static electricity sensor head, the number of samples to average has been set to 64 before shipment from the factory.



In general, when the number of samples to average is multiplied by "n", the resolution increases by \sqrt{n} .

CHECK!

Moving to the FUN mode and AVE

1. Set the mode switch to FUN.



2. Use the LEFT and RIGHT keys to display [AVE] on the main display.

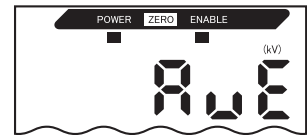

Selecting the number of samples to average

3. Press the UP or DOWN key.
The sub-display flashes.



4. Use the UP and DOWN keys to select the desired number of samples to average.



5. Press the ENT key to confirm the setting.
This registers the setting.



Using the Hold Functions

The "hold functions" hold data for specific points during the measurement period, such as the minimum and maximum values, and output those values after measurement ends.

■ Flow of Operation

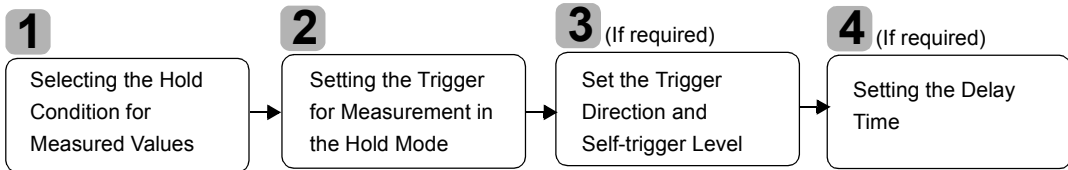

1 Selecting the Hold Condition for Measured Values

The time period from the start to the end of hold measurements is called the "sampling period."

The value to be held during that sampling period is selected here.



After sampling is started, the CLAMP value is output until the first sampling period ends.



What is the "CLAMP value?" p.77

CHECK!

Any of the seven settings shown in the following table can be selected as the hold condition.

Selection	Details
OFF (default)	Hold measurement is not performed. The measured value is always output.
P-H (Peak hold)	<p>The maximum value during the sampling period is held. The output changes at the end of the sampling period and is held until the end of the next sampling period.</p>
B-H (Bottom hold)	<p>The minimum value during the sampling period is held. The output changes at the end of the sampling period and is held until the end of the next sampling period.</p>

Section 5 Using the Hold Functions

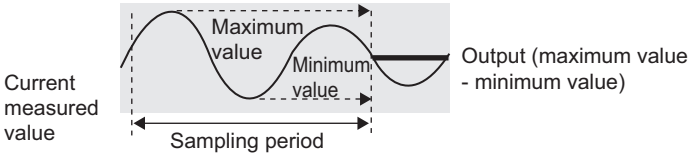
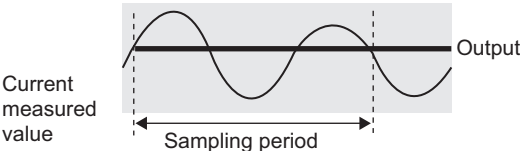
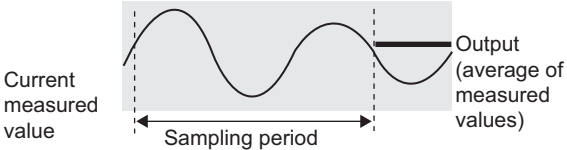
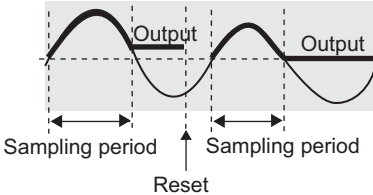
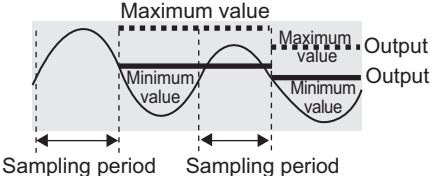
Selection	Details
PP-H (Peak-to-peak hold)	<p>The difference between the minimum and maximum values is held. Select this option mainly to detect vibration. The output changes at the end of the sampling period and is held until the end of the next sampling period.</p> 
S-H (Sample hold)	<p>The measured value at the start of the sampling period is held. The output changes at the start of the sampling period and is held until the start of the next sampling period.</p> 
AVE-H (Average hold)	<p>The average measured value during the sampling period is held. The output changes at the end of the sampling period and is held until the end of the next sampling period.</p> 
MASK (Mask hold)	<p>The measured value is updated only during the sampling period. When the sampling period ends, the measured value is held until the start of the next sampling period or until a reset signal is received.</p> 
PB-H (Peak-and-bottom hold)	<p>The minimum and maximum values during the sampling period are held. The maximum value is displayed on the main display and the minimum value is displayed on the sub-display.</p> 

Moving to the FUN mode and HOLD

1. Set the mode switch to FUN.
2. Use the LEFT and RIGHT keys to display [HOLD] on the main display.

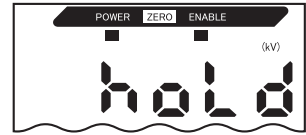
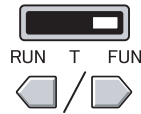





Selecting the hold condition

3. Press the UP or DOWN key.
The sub-display flashes.
4. Use the UP and DOWN keys to select the desired hold condition.
5. Press the ENT key to confirm the setting.
This registers the setting.

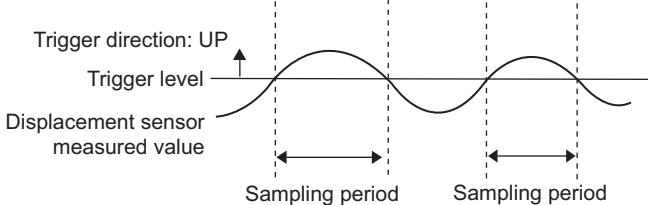

2 Setting the Trigger for Measurement in the Hold Mode

Use the UP and DOWN keys to select the desired measurement start conditions.

Selection	Details
TIMNG (Timing input) (default)	Enter the trigger for the start of sampling by using the timing input lead. The duration that the timing signal from the timing input lead is ON is the sampling period.  <p>Timing input ON OFF Sampling period</p> <p> CHECK! When a delay time is set, the input OFF timing and the end of the sampling period are not synchronous. Sampling ends after the specified sampling period has elapsed.</p>
DIST (distance trigger)	The duration that the displacement sensor detects the specified distance is the sampling period. This option can be selected only when a displacement sensor is used. (Example: When trigger direction = UP)  <p>Trigger direction: UP Trigger level Displacement sensor measured value Sampling period Sampling period</p> <p> CHECK! Specify the trigger direction, self-trigger level and self-trigger hysteresis width.</p>

Selecting the trigger type

- Use the LEFT and RIGHT keys to display [H-TRG] on the main display.

H-TRG is not displayed if the hold condition is set to [OFF].

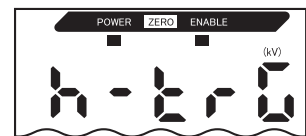

- Press the UP or DOWN key.

The sub-display flashes.



- 3.** Use the UP or DOWN key to select the desired trigger type.

There are two trigger types: [TIMNG] and [DIST].



- 4.** Press the ENT key to confirm the setting.

This registers the selected trigger type.



3 Setting the Trigger Condition

Select the input method for the timing of the start and end of the measurement period.



The trigger mode can be selected only when [DIST] is selected as the hold trigger.

CHECK!

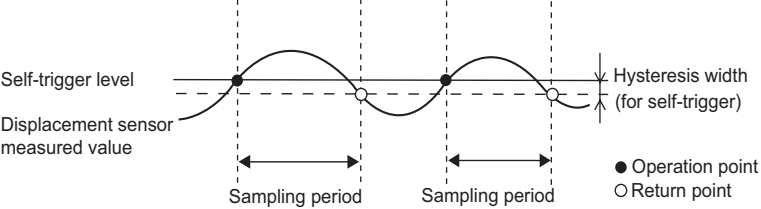
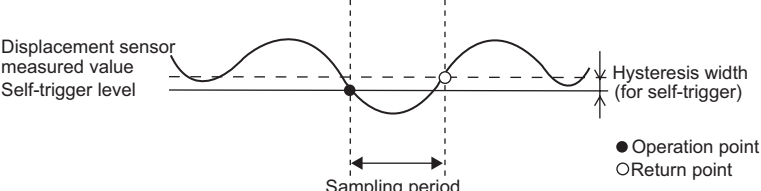
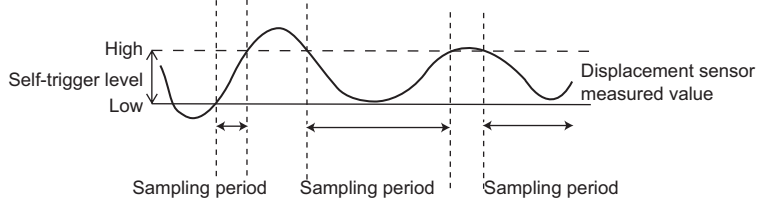
Selection	Details
UP (Self-up trigger) (default)	<p>The period in which the displacement sensor measured value is greater than the specified self-trigger level is the sampling period. Hold measurement is possible without a sync input. Specify self-trigger level -Low [H-LVL].</p>  <p>● Operation point ○ Return point</p>
DOWN (Self-down trigger)	<p>The period in which the displacement sensor measured value is lower than the specified self-trigger level is the sampling period. Hold measurement is possible without a sync input. Specify self-trigger level -High [H-LVH].</p>  <p>● Operation point ○ Return point</p>
WINDOW	<p>The period in the range between the displacement sensor measured value's high and low self-trigger levels is the sampling period. Specify self-trigger level -High [H-LVH] and self-trigger level -Low [H-LVL].</p> 



- Hysteresis (hysteresis width)
Set the hysteresis based on the fluctuations in the measured values around the trigger level. Hysteresis is applied from the start of the sampling period and prevents timing input chattering.
- Zero reset input is disabled during sampling or while [----] is displayed in the main display.
- The timing input signal is ignored if the self-trigger level is set to [UP] or [DOWN]. However, sampling is not affected.
- When a delay time is set, the timing when the measured value falls below or exceeds the self-trigger level is not synchronous with the end of the sampling period. Sampling ends after the specified sampling period has elapsed.

Selecting the trigger direction

1. Use the LEFT and RIGHT keys to display [H-TRD] on the main display.

H-TRD is not displayed if the hold condition is set to [OFF].

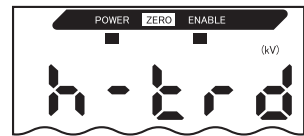

2. Press the UP or DOWN key.

The sub-display flashes.



3. Use the UP or DOWN key to select the desired trigger type.

[There are three trigger types: [UP], [DOWN] and [WINDOW].



4. Press the ENT key to confirm the setting.

This registers the selected trigger type.



Setting the self-trigger level (example: when [WINDOW] is selected as the trigger direction)



There are two self-trigger levels, [H-LVH] and [H-LVL]. The self-trigger level to be specified differs according to the trigger direction.

- When trigger direction = UP, specify [H-LVL].
- When trigger direction = DOWN, specify [H-LVH].
- When trigger direction = WINDOW, specify both [H-LVH] and [H-LVL].

Section 5 Using the Hold Functions

- 5.** Use the LEFT or RIGHT key to display [H-LVH] on the main display.
H-LVH is not displayed if timing input [TIMNG] is set as the trigger.

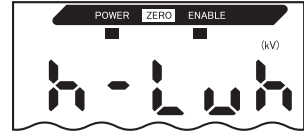

- 6.** Press the UP or DOWN key.
The leftmost digit of the sub-display flashes.



- 7.** Use the cursor keys to set the desired self-trigger level.



----- Moves from one digit to another.



----- Changes the numeric value.

- 8.** Press the ENT key to confirm the setting.
This registers the trigger level.



- 9.** Use the LEFT or RIGHT key to display [H-LVL] on the main display.
H-LVL is not displayed if timing input [TIMNG] is set as the trigger.

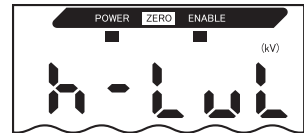

- 10.** Press the UP or DOWN key.
The leftmost digit of the sub-display flashes.



- 11.** Use the cursor keys to set the desired self-trigger level.



----- Moves from one digit to another.



----- Changes the numeric value.

- 12.** Press the ENT key to confirm the setting.
This registers the trigger level.



Setting the hysteresis width (when [DIST] is selected as the hold trigger)

- 13.** Use the LEFT and RIGHT keys to display [H-HYS] on the main display.
H-HYS is not displayed if timing input [TIMNG] is set as the trigger.

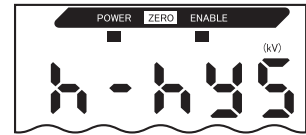

- 14.** Press the UP or DOWN key.
The leftmost digit of the sub-display flashes.



- 15.** Use the cursor keys to set the hysteresis width for the trigger level.



----- Moves from one digit to another.



----- Changes the numeric value.

- 16.** Press the ENT key to confirm the setting.
This registers the hysteresis width.



4 Setting the Delay Time

Set the delay time function, for example, to ignore measured values immediately after a hold trigger is detected in order to avoid fluctuation of signals near the sensing object boundary.

The delay time (the delay between detection of the trigger and start of sampling) and the sampling period can be set.

The default delay time setting is OFF.



- Make the sum of the delay time and sampling period less than the trigger detection interval.
- If the next trigger input for measurement is detected before the sum of the delay time and sampling period have elapsed, that trigger input is ignored and is not reflected in sampling.
- Triggers are detected when the hold trigger and trigger condition is satisfied (ex: when the timing input turns ON)

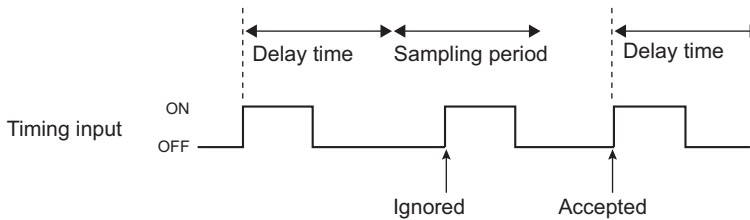

Moving to the delay hold (H-DLY)

1. Use the LEFT and RIGHT keys to display [H-DLY] on the main display.

H-DLY is not displayed if the hold condition is set to [OFF].

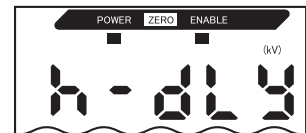

2. Press the UP or DOWN key.

The sub-display flashes.



3. Use the UP and DOWN keys to display [ON].



4. Press the ENT key.

The H-DLY function can now be set.



Setting the delay time

- 5.** Use the LEFT and RIGHT keys to display [H-D-T] on the main display.

H-D-T is not displayed if the H-DLY function is set to OFF.

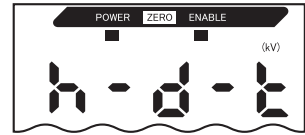

- 6.** Press the UP or DOWN key.

The leftmost digit of the sub-display flashes.



- 7.** Enter the delay time (ms).



----- Moves from one digit to another.



----- Changes the numeric value.

- 8.** Press the ENT key to confirm the setting.

This registers the delay time.



Setting the sampling period

- 9.** Use the LEFT and RIGHT keys to display [H-S-T] on the main display.

H-S-T is not displayed if the H-DLY function is set to OFF.

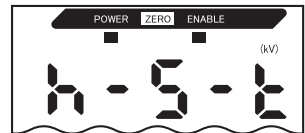

- 10.** Press the UP or DOWN key.

The leftmost digit of the sub-display flashes.



- 11.** Use the cursor keys to enter the sampling period (ms).



----- Moves from one digit to another.



----- Changes the numeric value.

- 12.** Press the ENT key to confirm the setting.

This registers the sampling period.



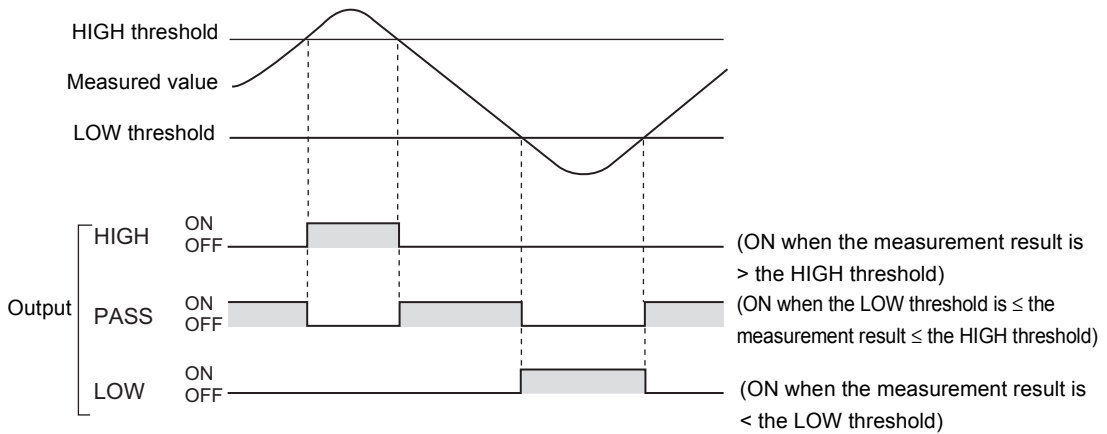

Entering Threshold Values

Threshold values are set to determine the range for PASS judgments. Both HIGH and LOW threshold values are set. There are three judgment outputs: "HIGH", "PASS" and "LOW".



The following table outlines the three methods for setting the threshold values.

Method	Details
Direct input	The threshold values can be set by directly inputting the numeric values. Direct input is useful when the criteria is known in advance or when adjusting threshold values after teaching.
Position teaching	Measurement is actually performed and the measurement results are used to set threshold values. Position teaching is useful when charge limit samples are available.
Automatic teaching	Measurement is performed continuously while the keys are held down, and the minimum and maximum measurements during that period are set as the threshold values. Automatic teaching is useful when you want to set threshold values by actually starting the device and obtaining real measurements.

 Hysteresis (hysteresis width) can also be set to threshold values. Set hysteresis when judgments are unstable to prevent chattering.
  p.69

Inputting Threshold Values Directly

Threshold values can be set by directly inputting numeric values.

Direct input is useful when you know the standard values of the static electricity sensor or when you want to fine-tune threshold values after teaching.

Moving to the T mode

1. Set the mode switch to T.



Setting threshold values

2. Move the threshold switch to either H or L, i.e., the threshold to be set.

The current measured value is displayed on the main display.

The currently set threshold value (either HIGH or LOW, depending on the threshold switch setting) is displayed on the sub-display.

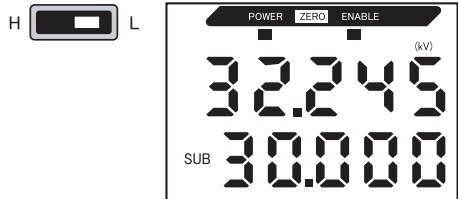

3. Press any cursor key.
The leftmost digit of the sub-display flashes.



4. Use the cursor keys to set the threshold value.

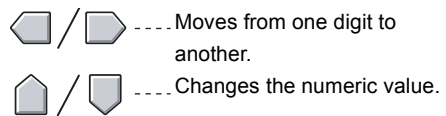

5. Press the ENT key to confirm the setting.
This registers the setting.



Countermeasures for setting errors

If [ERRLH] or [ERRHL] is displayed, either of the following errors has occurred:

- HIGH threshold value < LOW threshold value
- HIGH threshold value - LOW threshold value < hysteresis width

Hysteresis setting p.69

If an error is displayed, the threshold values have not been updated.

Set the threshold values again.



Position Teaching

Measurement is actually performed and the measurement results are used to set threshold values.

Position teaching is useful when threshold samples, i.e., with the upper and lower limits, can be obtained beforehand.

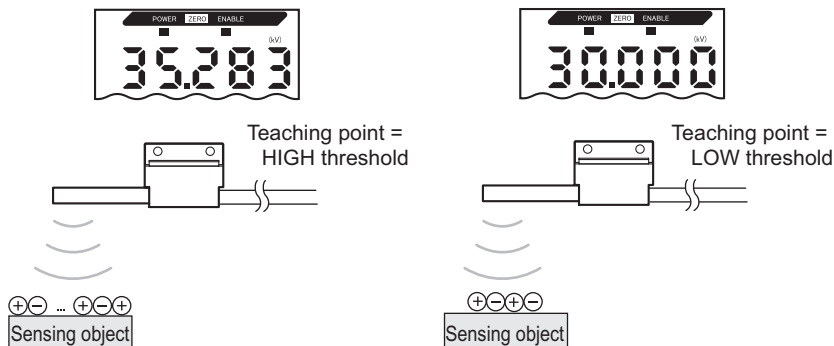

Hold, trigger mode, and scaling settings that have been made before teaching are reflected in the teaching measurements.

CHECK!

Moving to the T mode

1. Set the mode switch to T.



Setting threshold values

2. Move the threshold switch to either H or L, i.e., the threshold to be set.

The current measured value is displayed on the main display. The currently set threshold value (either HIGH or LOW, depending on the threshold switch setting) is displayed on the sub-display.

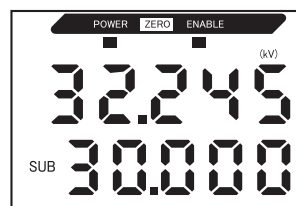

3. Place the threshold sample in position.

The main display value changes.

4. Press the ENT key for at least one second and then release it.

The measured value at the moment that the ENT key is released is set as the threshold value.

This threshold value is shown on the sub-display.



When [ERRLH] or [ERRHL] is displayed p.65



The threshold values set using position teaching can also be changed using direct input. This is useful when setting judgment tolerances for measured values.

CHECK!

p.65

Automatic Teaching

When automatic teaching is executed, measurement is performed continuously for the duration that the keys are held down, and the minimum and maximum measurements during that period are set as the threshold values.

Automatic teaching is useful when you want to set threshold values by actually starting the device and obtaining real measurements.

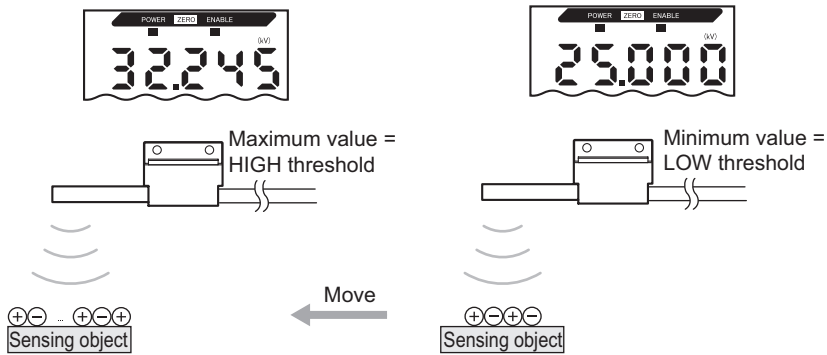

Hold, trigger mode, and scaling settings that have been made before teaching are reflected in the teaching measurements.

Moving to the T mode

1. Set the mode switch to T.



2. Start the device.



The threshold switch may be set to either position. Both HIGH and LOW thresholds are set, regardless of the switch setting.

Section 5 Entering Threshold Values

Setting threshold values

3. Start measurement.

Measurement continues for the duration that the ENT and RIGHT keys are held down.

[AUTOT] flashes on the sub-display.

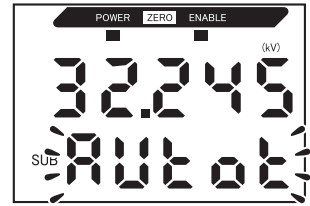

4. To end measurement, release the ENT and RIGHT keys.

The maximum measured value during the measurement period is set as the HIGH threshold value and the minimum measured value is set as the LOW threshold value.

The new threshold value (either HIGH or LOW, depending on the threshold switch setting) is displayed on the sub-display.



When [ERRLH] is displayed p.65



CHECK!

The threshold values set using automatic teaching can also be changed using direct input. This is useful when setting judgment tolerances for measured values.



p.65

Hysteresis Setting

Set the hysteresis width (difference between operation and return points) for the upper and lower limits of judgments if the HIGH, PASS, or LOW judgment is unstable near the sensing boundaries.

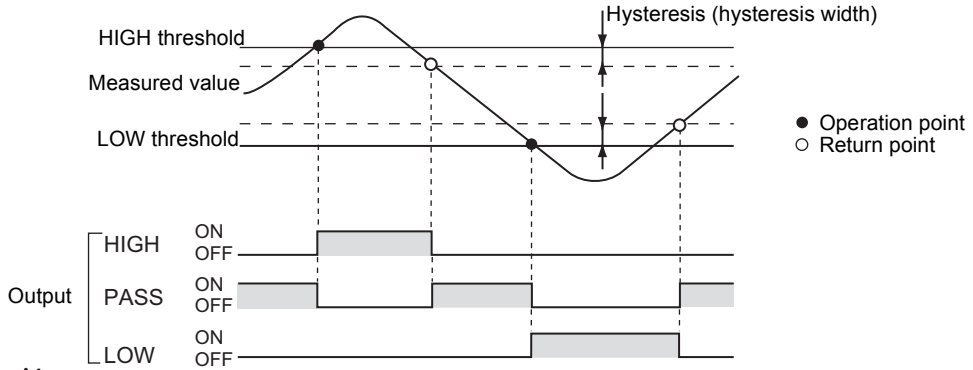

To prevent self-trigger chattering, set hysteresis for the self-trigger.

p.56

Moving to the FUN mode and HYS

1. Set the mode switch to FUN.
2. Use the LEFT and RIGHT keys to display [HYS] on the main display.
3. Press the UP or DOWN key.
The leftmost digit of the sub-display flashes.
4. Use the cursor keys to enter the hysteresis width.
5. Press the ENT key to confirm the setting.
This registers the setting.

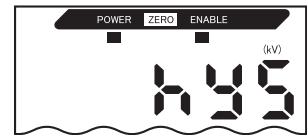
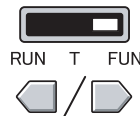

--- Moves from one digit to another.

--- Changes the numeric value.

Countermeasures for setting errors

If [ERROV] is displayed, HIGH threshold - LOW threshold < the hysteresis width.

If an error is displayed, the threshold values have not been updated.

Set the values again or change the threshold values.



Linear Output

Output Settings (Monitor Focus)

"Linear output" refers to the conversion of measurement results to a 3 to 21 mA current output range or a -5 to +5 V voltage output range. The relationship between displayed measured values and output values can be set freely. Match the settings to suit the connected external device.

Enter the output values for any two current values or voltage values to set the output range.

Example: Setting 5 kV to 4 mA output and 15 kV to 20 mA output (for current output)

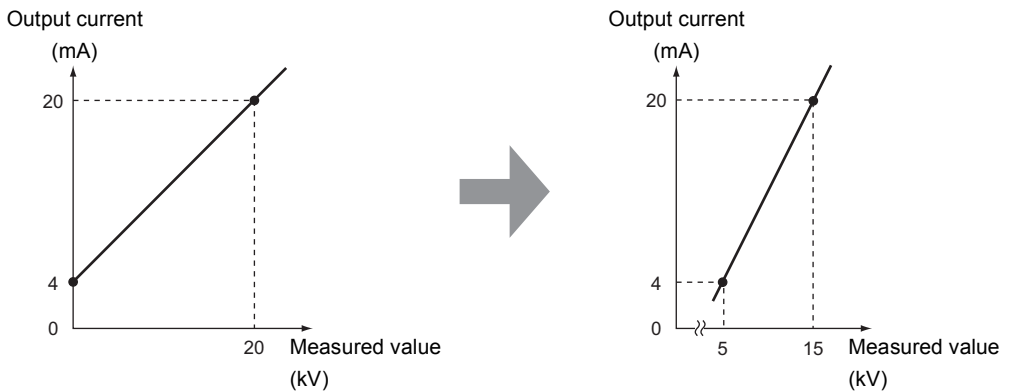

Allow at least 1 kV between the two points to specify.

CHECK!



The threshold values are cleared when the monitor focus is set. Reset the threshold values after setting the monitor focus.

CHECK!



Threshold p.36

This section describes how to set the output range, using an example of current output with a range with the following conversions: 5 kV to 4 mA and 15 kV to 20 mA. Change the values in this example for voltage output as necessary.

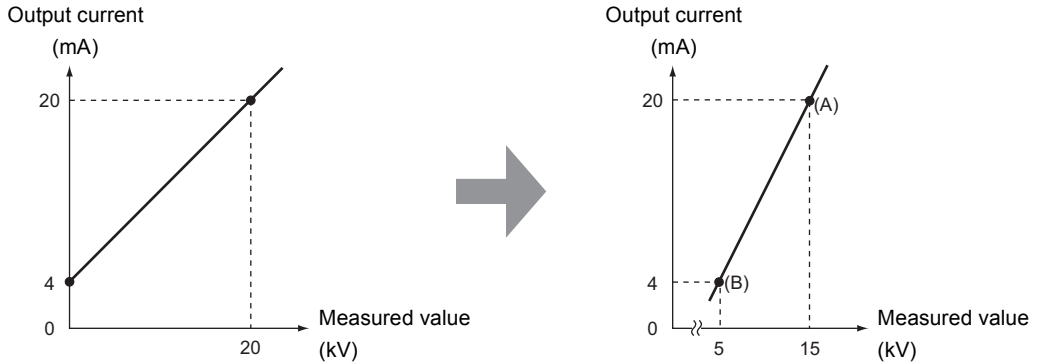

1. Turn OFF the Amplifier Unit.
2. Move the current/voltage switch to current output. The switch is located on the bottom of the Amplifier Unit.
The default setting is voltage output.

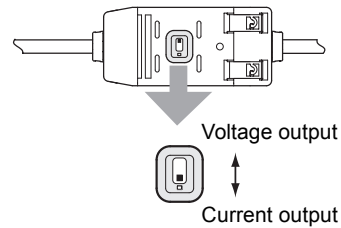

Moving to the FUN mode and SPCL

3. Turn ON the Amplifier Unit and move the mode switch to FUN.
4. Use the LEFT and RIGHT keys to display [SPCL] on the main display.

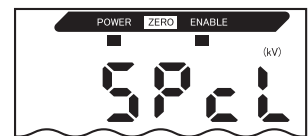

Moving to FOCUS

5. Press the UP or DOWN key.
The sub-display flashes.
6. Use the UP and DOWN keys to display [SET] or [ALL].
7. Press the ENT key.



Section 5 Linear Output

8. Use the LEFT and RIGHT keys to display [FOCUS] on the main display.

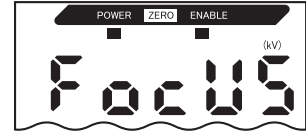

Selecting current (mA) or voltage (V) output

9. Press the UP or DOWN key.



The sub-display flashes.



10. Display [mA].



Always select the same output as the current/voltage switch selection on the bottom of the Amplifier Unit.
CHECK!

Setting the first point (A)

11. Press the ENT key.



The display changes to the display for setting the first point (A).

The output current value is displayed on the main display.

The corresponding measured value is displayed on the sub-display and the leftmost digit flashes.

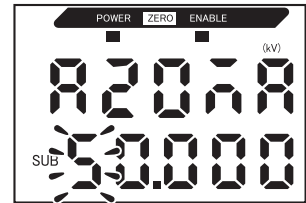

12. Set the output current value and the corresponding measured value for the first point.



--- Moves from one digit to another.

Set a measured value within the measuring range. If scaling or calculation has been set, set a value that reflects those settings.



--- Changes the numeric value.



CHECK!

The flashing digit, i.e., the digit to which a value can be set, changes as shown in the diagram.

Digit shift on sub-display

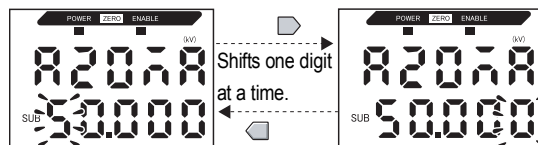

Switching from the sub-display to the main display and vice versa (from the leftmost/rightmost digit of the sub-display)

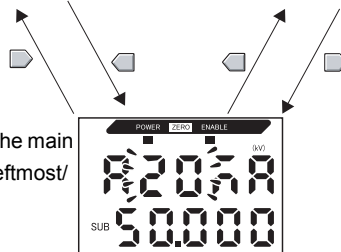

- 13.** Press the ENT key to confirm the setting.
This confirms the setting for the first point.
The screen for setting the second point is displayed.

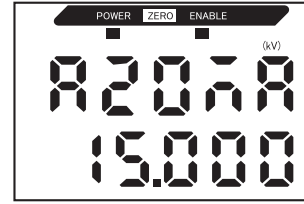

Setting the second point (B)

- 14.** Use the same procedure as for the first point to set the output current value and corresponding measured value for the second point.

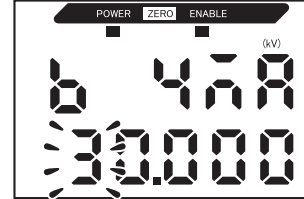

- 15.** Press the ENT key to confirm the setting.

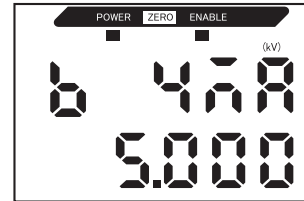

Confirming completion of monitor focus settings

The display indicates [OK] if monitor focus has been set correctly.

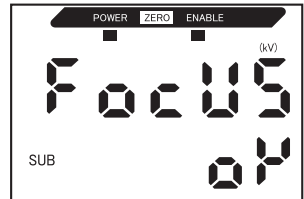

If not, the display indicates [NG].

If [NG] is displayed, check the following points and execute the monitor focus again.

- Is the measured value set on the sub-display within the measuring range (with scaling and calculation settings reflected if set)?
- Are the measured values of the first and second points separated by at least 1% of the rated measuring range?
- Are the current (or voltage) values for the two points the same?

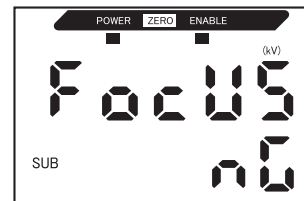

Correcting Linear Output Values

Discrepancies may occur between the linear output current (or voltage) values set on the Amplifier Unit and the actual current (or voltage) values measured due to the conditions for the connected external device or other factors. The linear output correction function can be used to correct this discrepancy.

Output values are corrected by entering the correction value for the current (or voltage) values of any two points.



Set the monitor focus function and select either current or voltage output beforehand.

p.70

This section uses current output as an example. Change the values in this example for voltage output as necessary.

1. Connect the linear output to an external ammeter.

Moving to the FUN mode and SPCL

2. Turn ON the Amplifier Unit and move the mode switch to FUN.



3. Use the LEFT and RIGHT keys to display [SPCL] on the main display.

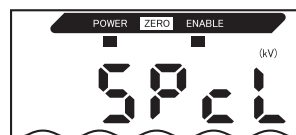

Moving to L-ADJ

4. Press the UP or DOWN key.
The sub-display flashes.



5. Use the UP and DOWN keys to display [SET] or [ALL].



6. Press the ENT key.



7. Use the LEFT and RIGHT keys to display [L-ADJ] on the main display.



The units for the monitor focus settings (mA or V) are displayed on the sub-display.

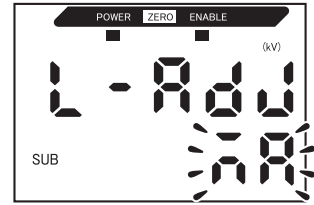

8. Press the ENT key.



The display changes to the display for setting the first point (A).

The output current value is displayed on the main display.

The correction value is displayed on the sub-display and the leftmost digit flashes.

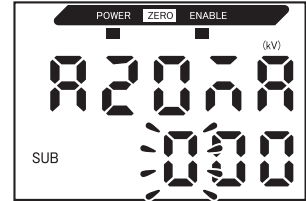

Setting the first point (A)

9. Set the output current and correction values for the first point.



--- Moves from one digit to another.



--- Changes the numeric value.

Adjust the correction value on the sub-display so that the ammeter reading and the output current shown on the main display are the same.

The larger the correction value, the larger the output current.

The correction value can be set within the range -999 to 999.

To set a negative value, make the leftmost digit of the sub-display flash and change the value.

If the correction value changes by 4, the linear output will change by approx. 1.4 μ A (0.7 mV).



The flashing digit, i.e., the digit to which a value can be set, changes as shown in the diagram.

CHECK!

Digit shift on sub-display

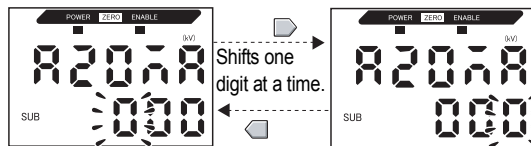

Switching from the sub-display to the main display and vice versa (from the leftmost/rightmost digit of the sub-display)

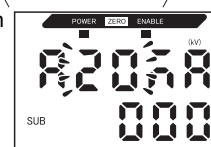

10. Press the ENT key to confirm the setting.



This confirms the correction value for the first point.

The screen for setting the second point is displayed.

Setting the second point (B)

11. Use the same procedure as the first point to set the correction value for the second point.

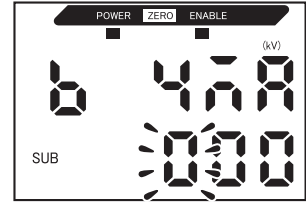

12. Press the ENT key.



Confirming setting results

If linear output correction has been registered correctly, the sub-display will show [OK].

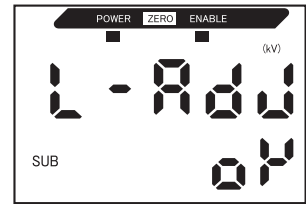

If not, the display indicates [NG].

Check that the current (or voltage) values for the two points are not the same and execute again.

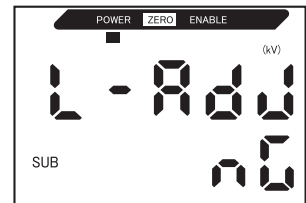

Output Settings for Non-measurement

The linear output method for when a reset is input can be set.

Selection	Outputs	
	Judgment outputs	Linear output
KEEP (default)	The measured value immediately before measurement is stopped is held and output.	
CLAMP	All outputs turn OFF.	The set CLAMP value is output. The following options are available: <ul style="list-style-type: none"> • At current output: 3 to 21 mA or maximum (approx. 23 mA) • At voltage output: -5 to 5 V or maximum (approx. 5.5 V)



CHECK!

- In the case of hold measurement
Even if [KEEP] is set, the output before the first hold value is obtained is the same as [CLAMP].
- Even in FUN mode, the outputs are made according to the non-measurement settings.

Moving to the FUN mode and SPCL

1. Set the mode switch to FUN.



2. Use the LEFT and RIGHT keys to display [SPCL] on the main display.

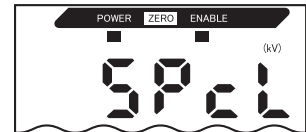

Moving to RESET

3. Press the UP or DOWN key.
The sub-display flashes.



4. Use the UP and DOWN keys to display [ETC] or [ALL].



5. Press the ENT key.



Section 5 Linear Output

- 6.** Use the LEFT and RIGHT keys to display [RESET] on the main display.



Selecting output status at non-measurement

- 7.** Press the UP or DOWN key.
The sub-display flashes.



- 8.** Use the UP and DOWN keys to select either KEEP or CLAMP.



- 9.** Press the ENT key to confirm the setting.
This registers the setting.
Next, set the clamp value if [CLAMP] is selected.



Setting the clamp value (only when CLAMP is selected)

- 10.** Use the LEFT and RIGHT keys to display [CLAMP] on the main display.
[CLAMP] is not displayed if [KEEP] has been selected.

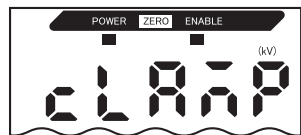

- 11.** Press the UP or DOWN key.
The sub-display flashes.



- 12.** Select the clamp value.



- 13.** Press the ENT key to confirm the setting.
This registers the setting.



Setting Judgment Output Timing (Timer)

The timing of judgment outputs can be adjusted to match the operation of external devices.

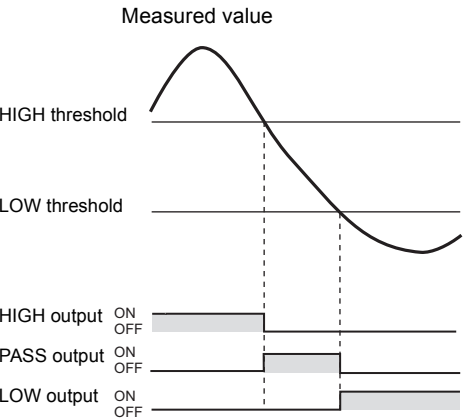
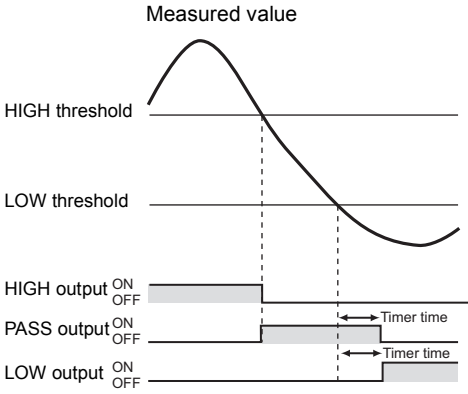
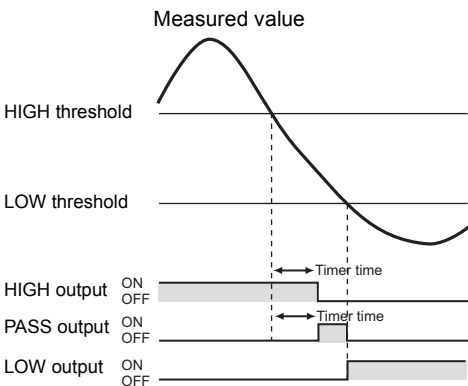
Selection	Details	
<p>OFF</p> <p>(default)</p>	<p>The judgment is output as soon as the judgment result has been confirmed.</p>	 <p>Measured value</p> <p>HIGH threshold</p> <p>LOW threshold</p> <p>HIGH output ON OFF</p> <p>PASS output ON OFF</p> <p>LOW output ON OFF</p>
<p>OFF-D (OFF-delay timer)</p>	<p>After the judgment result has been confirmed, changing of the PASS output state to OFF is delayed by the time set to the timer.</p> <p>Also, changing of the HIGH and LOW output states to ON is delayed by the time set to the timer.</p>	 <p>Measured value</p> <p>HIGH threshold</p> <p>LOW threshold</p> <p>HIGH output ON OFF</p> <p>PASS output ON OFF</p> <p>LOW output ON OFF</p> <p>Timer time</p>
<p>ON-D (ON-delay timer)</p>	<p>After the judgment result has been confirmed, changing of the PASS output state to ON is delayed by the time set to the timer.</p> <p>Also, changing of the HIGH and LOW output states to OFF is delayed by the time set to the timer.</p>	 <p>Measured value</p> <p>HIGH threshold</p> <p>LOW threshold</p> <p>HIGH output ON OFF</p> <p>PASS output ON OFF</p> <p>LOW output ON OFF</p> <p>Timer time</p>

Section 5 Setting Judgment Output Timing (Timer)

Selection	Details	
1-Sht (One-shot timer)	<p>When the judgment result changes from HIGH to PASS or from LOW to PASS, the PASS output turns ON with a pulse width equivalent to the time set to the timer.</p> <p>Neither the HIGH nor the LOW output is output.</p>	

The following description uses the OFF-delay timer as an example. Change the values in this example if other timers are used.

Moving to the FUN mode and TIMER

1. Set the mode switch to FUN.



2. Use the LEFT and RIGHT keys to display [TIMER] on the main display.

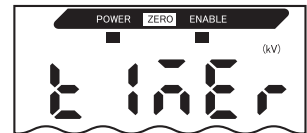

Selecting the type of timer

3. Press the UP or DOWN key.
The sub-display flashes.



4. Use the UP or DOWN key to select the desired timer type.



- 5.** Press the ENT key to confirm the setting.
This registers the setting.
If anything other than [OFF] is selected, set the timer time by the following procedure.



Setting the timer time (when a timer type other than [OFF] is selected)

- 6.** Use the LEFT and RIGHT keys to display [T-TIM] on the main display.
T-TIM cannot be displayed if [OFF] is selected.

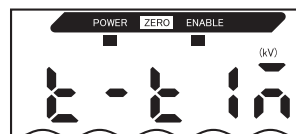

- 7.** Press the UP or DOWN key.
The leftmost digit of the sub-display flashes.



- 8.** Use the cursor keys to set the timer time (ms).



--- Moves from one digit to another.



--- Changes the numeric value.

- 9.** Press the ENT key to confirm the setting.
This registers the setting.



Setting the Warning Level (Output type)

Threshold values (warning level) other than HIGH, PASS or LOW can be set and displayed.

Selection	Details	
STAND (standard) (default)	The warning level is not set. Only the HIGH, PASS or LOW judgments are output.	When timer = OFF Measured value
WARN (warning)	The warning level is set. Next, specify the warning level value. CHECK! <ul style="list-style-type: none">The warning status continues to be output until one of "reset input ON", "switching to FUN mode" or "power OFF".The warning level value is set to the plus and minus directions. (Example: When "15" is specified, the +15 and -15 become the warning level values.)	When timer = OFF Measured value

■ Judgment output (judgment indicator)

Hold	Output type	OPE1	OPE2	OPE3
Other than peak and bottom hold	Standard	HIGH	PASS	LOW
	Warning	WARN	OK	NG
Peak and bottom hold	Not related	WARN	Peak-OK	Bottom-OK

OK: Judged as PASS

NG: Other than PASS (HIGH or LOW)

WARN: ON in warning state

Peak-OK: ON when the peak hold result is OK (PASS)

Bottom-OK: ON when the bottom hold result is OK (PASS)

Moving to the FUN mode and OUTPT

1. Set the mode switch to FUN.



2. Use the LEFT and RIGHT keys to display [SPCL] on the main display.

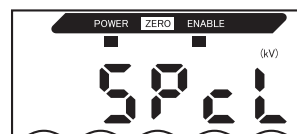

3. Press the UP or DOWN key.
The sub-display flashes.



4. Use the UP and DOWN keys to display [ETC] or [ALL].



5. Press the ENT key.



6. Use the LEFT and RIGHT keys to display [OUTPT] on the main display.

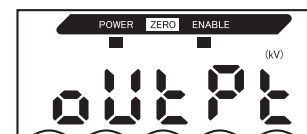

Selecting the output type

7. Press the UP or DOWN key.
The sub-display flashes.



8. Select the output type.
When a warning level is set, select [WARN], and when not set, select [STAND].



9. Press the ENT key to confirm the setting.
This registers the setting.
When [WARN] is selected, set the warning level.



Section 5 Setting the Warning Level (Output type)

Setting the warning level (only when [WARN] is selected as the output type)

- 10.** Use the LEFT and RIGHT keys to display [WARN] on the main display.



- 11.** Press the UP or DOWN key.
The leftmost digit of the sub-display flashes.



- 12.** This sets the warning level value.



---- Moves from one digit to another.



---- Changes the numeric value.

- 13.** Press the ENT key to confirm the setting.
This registers the setting.



Using the Area Correction Function

The detection area of the static electricity sensor changes and the average electric potential value inside the detection area is displayed according to the distance between the workpiece and the sensor head. This is why the area correction function is provided so that the area of the sensing target can be specified and an accurate electric potential can be displayed.

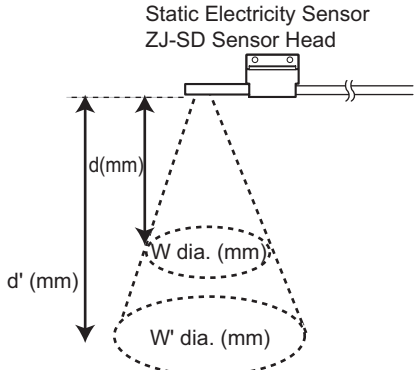
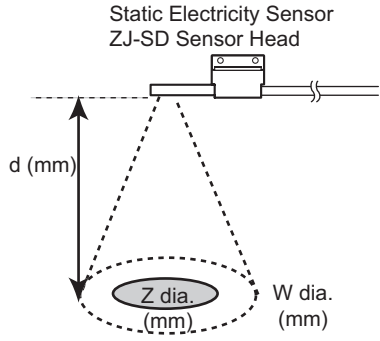

The area sometimes cannot be corrected correctly due to the charged state and the environment around the sensing object. If this happens, use the sensor with the area correction function set to OFF.

Selection	Details	
<p>OFF</p> <p>(default)</p>	<p>The entire area is measured.</p>	 <p>Static Electricity Sensor ZJ-SD Sensor Head</p> <p>d (mm)</p> <p>d' (mm)</p> <p>W dia. (mm)</p> <p>W' dia. (mm)</p> <p>Average electric potential value of W and W' is calculated.</p> <p>Lightbulb icon: Detection area (W, W') differs according to distance (d, d') between workpiece and sensor head.</p> <p>CHECK!</p>
<p>ON</p>	<p>Only a specific area is measured. Specify the size of the area [SIZE].</p> <p>Lightbulb icon: Enter the size of the area to be sensed (mm dia.) as the [SIZE].</p> <p>CHECK!</p>	 <p>Static Electricity Sensor ZJ-SD Sensor Head</p> <p>d (mm)</p> <p>Z dia. (mm)</p> <p>W dia. (mm)</p> <p>Numerical value after correction on electric potential value in range Z is displayed.</p> <p>Lightbulb icon: Electric potential value after distance correction with detection area (W) is determined from distance d measured by displacement sensor.</p> <p>CHECK!</p>

Section 5 Using the Area Correction Function

Moving to the FUN mode and AREA

1. Set the mode switch to FUN.



2. Use the LEFT and RIGHT keys to display [AREA] on the main display.

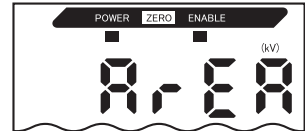

Selecting area correction

3. Press the UP or DOWN key.
The sub-display flashes.



4. Select whether or not to enable the area correction function.
To use the area correction function, select [ON].



5. Press the ENT key to confirm the setting.
This registers the setting.
Next, set the area size if [ON] is selected.



Setting the area size (only when [ON] is selected)

6. Use the LEFT and RIGHT keys to display [SIZE] on the main display.
SIZE is not displayed if [OFF] is selected.

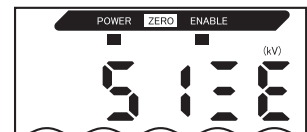





7. Press the UP or DOWN key.
The leftmost digit of the sub-display flashes.



8. Set the size of the area.

Enter the size of the area to be sensed (mm dia.) as the [SIZE].

 /  ---- Moves from one digit to another.

 /  ---- Changes the numeric value.

9. Press the ENT key to confirm the setting.

This registers the setting.



Selecting Banks

Up to four setting patterns can be stored in the ZJ-SD, and a set of these patterns is called a "bank."



- Four banks can be selected.
- Banks are switched by external input leads or the amplifier (bank switching in the FUN mode [BANK]).
- Switching by external input leads is possible only in the RUN mode.
- Measurement stops during bank switching. Measurement is resumed after the setting data in the banks is loaded to RAM and setting processing ends.

Bank is switched by [External input lead] or in FUN mode [BANK].

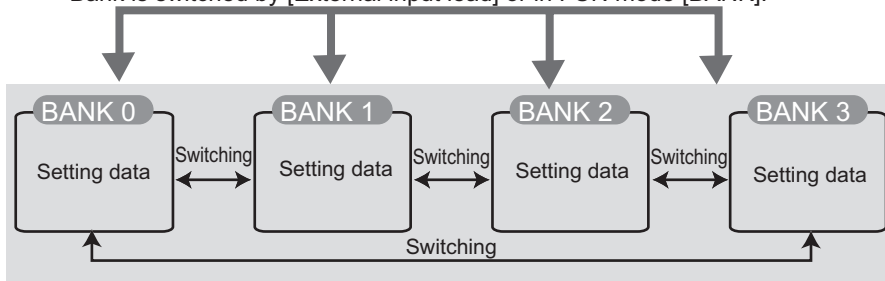

■ Procedure for switching banks from an external input lead

The following describes the procedure for switching banks using external input leads (8), (9), (10) and (11) in the RUN mode.

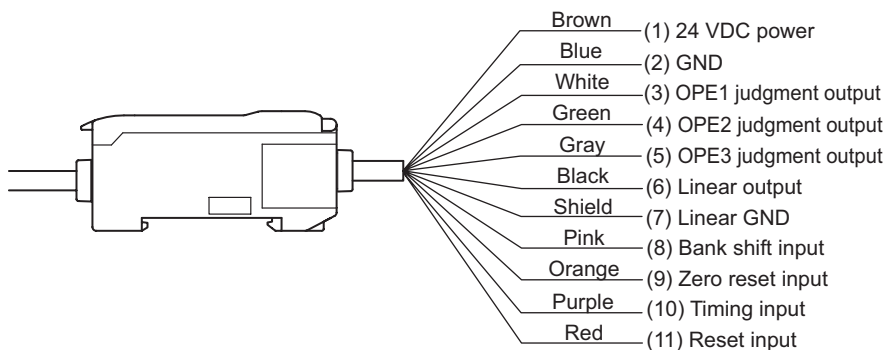

Switching how input leads are to be used

1. Turn the pink (8) Bank shift input ON.

The functions of input leads (9), (10) and (11) change as follows:

Orange (9) Zero reset input → Execution of bank switching

Purple (10) Timing input → Bank selection 1

Red (11) Reset input → Bank selection 2



Turn pink (8) Bank shift input OFF when not switching banks.

Selecting banks

2. Turn (10) Bank input 1 and (12) Bank input 2 ON/OFF.

Banks are specified by the combination of the ON/OFF settings of these two inputs.

Bank No. and External Input Lead

Bank No.	External input lead	
	Purple (10) Bank input 1	Red (11) Bank input 2
0	OFF	OFF
1	ON	OFF
2	OFF	ON
3	ON	ON

Switching banks

3. Switch (9) Execution of bank switching OFF → ON → OFF.

The currently selected bank is switched to at the moment that execution of bank switching input switched from ON → OFF.

[Bank switching timing]
(BANK 1 switching example)

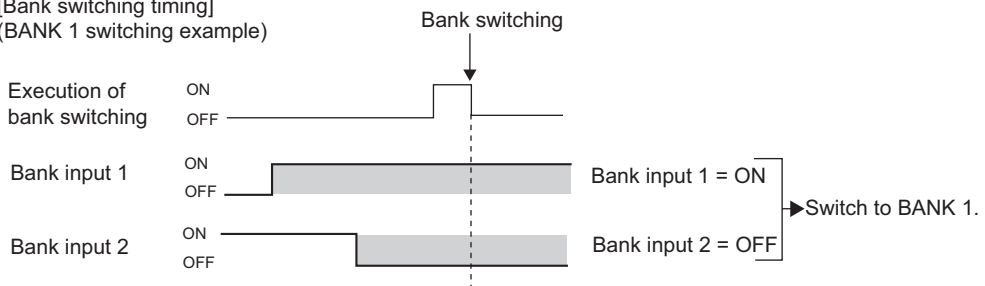

■ Procedure for switching banks from an amplifier

Moving to the FUN mode and BANK

- 1.** Set the mode switch to FUN.



- 2.** Use the LEFT and RIGHT keys to display [BANK] on the main display.

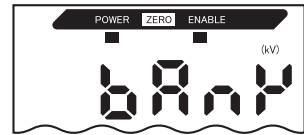

Selecting banks

- 3.** Press the UP or DOWN key.
The sub-display flashes.



- 4.** Select the bank No.
0 to 3 can be selected.



- 5.** Press the ENT key to confirm the setting.
This switches to the specified bank.



Section 6

AUXILIARY FUNCTIONS

☒ Changing the Number of Display Digits	92
☒ Reversing the Display	93
☒ Adjusting Display Brightness (ECO Display)	95
☒ Key Lock Function	96
☒ Initializing Setting Data	97
☒ Changing Display Scales	99
☒ Comparing Measured Values (Differentiation Function)	105

Changing the Number of Display Digits

Select the number of digits (0 to 5) for the main and sub-displays in the RUN mode. The default setting is five digits. When four or less digits are set, the digits are disabled from the rightmost digit first.

If zero (0) digits are set, all the digital displays go out.

Moving to FUN and SPCL

1. Set the mode switch to FUN.



2. Use the LEFT and RIGHT keys to display [SPCL] on the main display.

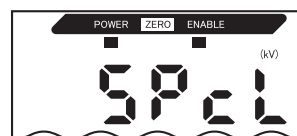

Moving to DIGIT

3. Press the UP or DOWN key.
The sub-display flashes.



4. Use the UP and DOWN keys to display [DISP] or [ALL].



5. Press the ENT key.



6. Use the LEFT and RIGHT keys to display [DIGIT] on the main display.

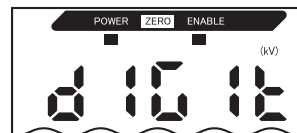

Selecting the number of display digits

7. Press the UP or DOWN key.
The sub-display flashes.



8. Use the UP and DOWN keys to select the desired number of display digits.



9. Press the ENT key to confirm the setting.



Reversing the Display

The main and sub-digital displays can be reversed, i.e., be turned upside down. Cursor key operation also is reversed. This function is useful when mounting the Amplifier Unit upside down on a device.

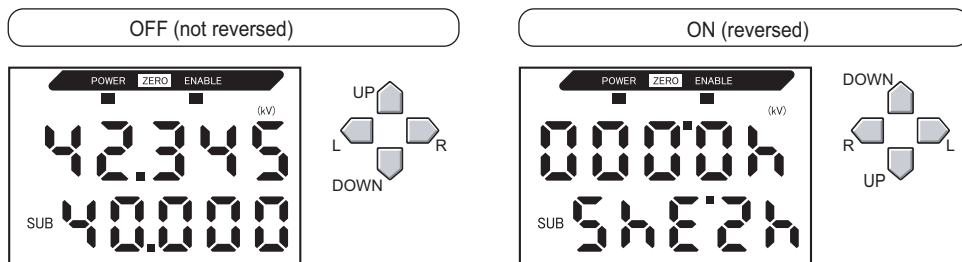

Moving to FUN and SPCL

1. Set the mode switch to FUN.
2. Use the LEFT and RIGHT keys to display [SPCL] on the main display.

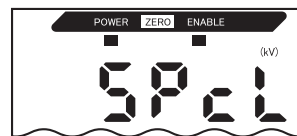
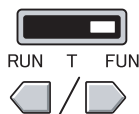

Moving to DREV

3. Press the UP or DOWN key.
The sub-display flashes.
4. Use the UP and DOWN keys to display [DISP] or [ALL].
5. Press the ENT key.
6. Use the LEFT and RIGHT keys to display [DREV] on the main display.

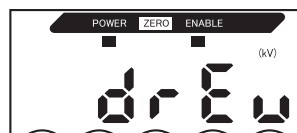

Section 6 Reversing the Display

Selecting whether or not to reverse display

- 7.** Press the UP or DOWN key.
The sub-display flashes.



- 8.** Select either [OFF] or [ON].
OFF: Display not reversed (default)
ON: Display reversed



- 9.** Press the ENT key to confirm the setting.
This registers the setting.
When [ON] is selected, the display is reversed.

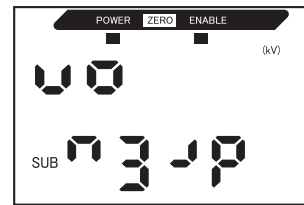

Adjusting Display Brightness (ECO Display)

When the ECO display function is used, the digital displays darken, reducing current consumption.

Moving to FUN and SPCL

1. Set the mode switch to FUN.



2. Use the LEFT and RIGHT keys to display [SPCL] on the main display.

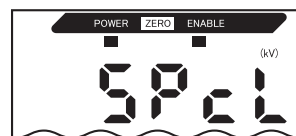

Moving to ECO

3. Press the UP or DOWN key.
The sub-display flashes.



4. Use the UP and DOWN keys to display [DISP] or [ALL].



5. Press the ENT key.



6. Use the LEFT and RIGHT keys to display [ECO] on the main display.

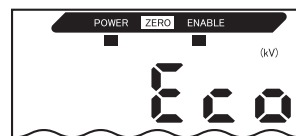

Selecting whether or not to use the ECO display function

7. Press the UP or DOWN key.
The sub-display flashes.



8. Select either [OFF] or [ON].
OFF: Normal display (default)
ON: ECO display



9. Press the ENT key to confirm the setting.
This registers the setting.
When [ON] is selected, the display darkens.



Key Lock Function

The key lock function disables all Amplifier Unit keys. Once the keys have been disabled, no key input is accepted until the lock is canceled. This function is useful to prevent inadvertent changes to settings.

The mode and threshold switches are still enabled even when the key lock function is ON.

Setting the Key Lock

1. Set the mode switch to FUN.
2. Hold down the UP, DOWN, RIGHT, and LEFT keys at the same time.
The main display indicates [LOCK].
The sub-display indicates [----].
3. Release the keys once [OK] is displayed on the sub-display.

This locks the keys.

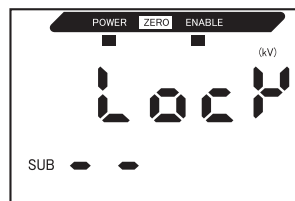
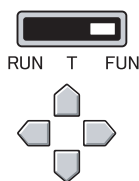

Canceling the Key Lock

1. Set the mode switch to FUN.
2. Hold down the UP, DOWN, RIGHT, and LEFT keys at the same time.
The main display indicates [FREE].
The sub-display indicates [----].
3. Release the keys once [OK] is displayed on the sub-display.
This cancels the key lock.

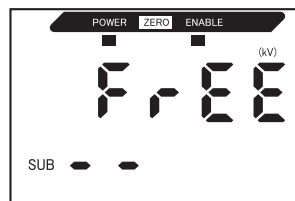
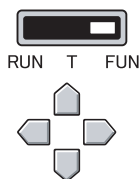

Initializing Setting Data

Initialization resets the settings of all banks or the currently selected bank to their default values.



CHECK!

- There are two [INIT] options, [ALL] and [NOW].
[ALL]: This initializes all banks (0 to 3).
[NOW]: This initializes the currently selected bank.
- After bank(s) are initialized, the currently selected bank never switches to bank 0.

Default Value

Function	Default Value
Measurement mode	Standard
Number of samples to average	When connected to the static electricity sensor head (ZJ-SD100): 64 times
Hysteresis width	0.1 kV
Distance measurement mode	User
Sensor distance value	10 mm
Area correction	OFF
Hold	OFF
Timer	OFF
Special function	CLOSE
Scaling	OFF
Monitor focus	Minimum value inside rated measuring range: -4 V (at voltage output), 4 mA (at current output) Maximum value inside rated measuring range: +4 V (at voltage output), 20 mA (at current output)
Linear output correction	No correction
Display reverse	OFF
ECO display function	OFF
Display digit limit	5 digits (all)
Non-measurement settings	KEEP
Zero reset memory	ON
HIGH threshold	Maximum display value
LOW threshold	Minimum display value
Differentiation function	OFF
Zero reset function	Canceled
Sub-display	Threshold
Output type	Standard
Warning level	Maximum display value

Section 6 Initializing Setting Data

Moving to the FUN mode and INIT

1. Set the mode switch to FUN.
2. Use the LEFT and RIGHT keys to display [INIT] on the main display.

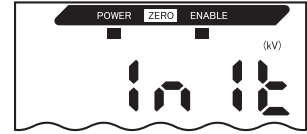
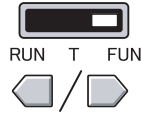

Selecting initialization of all banks/initialization of currently selected bank

3. Press the UP or DOWN key.
The sub-display flashes.



4. Select [ALL] or [NOW].

ALL: Initializes all banks.

NOW: Initializes only the currently selected bank.



5. Press the ENT key.



6. Press and hold down the ENT Key.

The sub-display indicates [----].



7. Release the ENT key once [OK] is displayed on the sub-display.

This initializes all settings.



Changing Display Scales

Change the display scale when you want to display a value on the main display that is different from the actual measured value.

Place an actual sensing object in position.

Two setting methods are available: one-point and two-point scaling.



- The scaling values set here are reflected in the display only.
To change the linear output of the displayed value, the monitor focus function must be used.
The minimum display value is -19999, and the maximum display value is 59999.

p.70

- The settings below return to their default settings when scaling is set.
Make the settings for these items after scaling settings are completed.

Self-trigger level p.59
Threshold p.36

One-point Scaling

Measurement is performed at one point and offset values are set for that measured value.

The offset and increment/decrement reversal (display inversion) can be set.

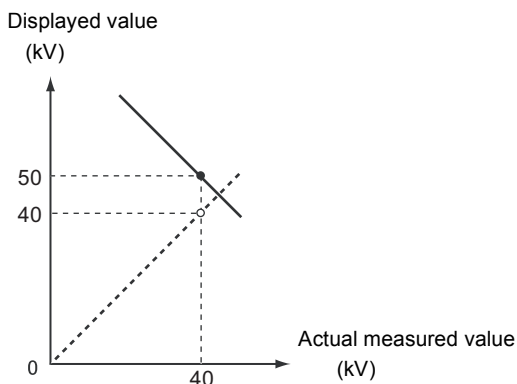

Moving to the FUN mode and SCALE

- Set the mode switch to FUN.



- Use the LEFT and RIGHT keys to display [SCALE] on the main display.

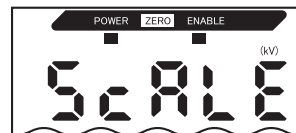

Section 6 Changing Display Scales

Executing scaling

- 3.** Press the UP or DOWN key.
The sub-display flashes.



- 4.** Use the UP and DOWN keys to display [ON].



- 5.** Press the ENT key to confirm the setting.
The sub-display indicates [P1SCL].

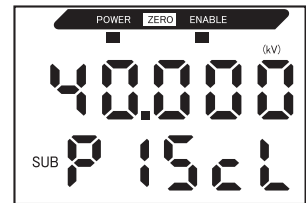

- 6.** Place the sensing object at the position where the display value change is required.



Place the sensing object within the measuring range. The ENABLE indicator lights when the sensing object is within the measuring range. Scaling is not possible if the sensing object is not within the CHECK! measuring range.

- 7.** Press any cursor key.
The current measured value is displayed on the main display.
The leftmost digit of the sub-display flashes.

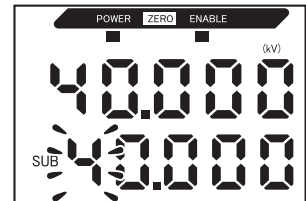
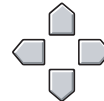

- 8.** Use the cursor keys to set the offset for the measured value in the sub-display.
The decimal point position can be changed as follows.



---- Moves from one digit to another.



---- Changes the numeric value.

- 9.** Press the ENT key to confirm the setting.
The decimal point flashes.



- 10.** Use the LEFT and RIGHT keys to change the decimal point position, if necessary.



- 11.** Press the ENT key to confirm the setting.
The inverted display settings appear on the sub-display.



Selecting inverted display

- 12.** Use the UP and DOWN keys to select the inverted display function.



Selection	Details
D-FWD	Not inverted The measured value displayed on the Amplifier Unit increases as the charge of the workpiece increases.
D-INV	Inverted The measured value displayed on the Amplifier Unit decreases as the charge of the workpiece increases.

- 13.** Press the ENT key to confirm the setting.
The sub-display indicates "P2SCL".



- 14.** Press the ENT key.



Section 6 Changing Display Scales

Confirming completion of scaling

If scaling has been completed correctly, the display indicates [OK].

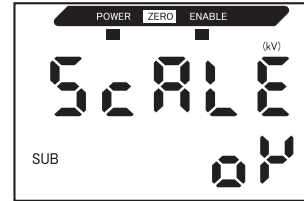

If scaling was not possible, the display indicates [NG].
Check that the ENABLE indicator is lit, and execute scaling again.

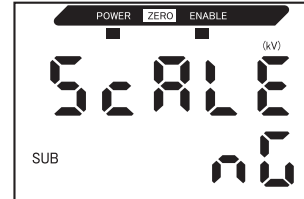

Two-point Scaling

Measurement is performed at two points and offset values are set for those measured values.

Both an overall offset can be set and the range can be changed.

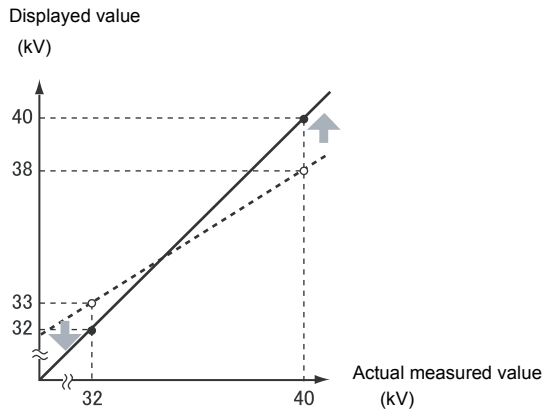

Allow at least 1 kV between the two points to specify.

CHECK!

Setting the first point

1. Set the first point by following steps 1. to 11. of the one-point scaling procedure.

p.99



The span for two-point scaling is automatically set based on the values entered for the two points. Inverted display settings are ignored.

CHECK!

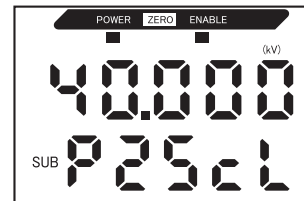

Setting the second point

2. Place the sensing object in the position (second point) for which the display is to be changed.



The sensing object must be set at a distance at least 1% of the rated measuring range away from the first point and also at a distance within the measuring range.

CHECK!

Section 6 Changing Display Scales

3. Press any cursor key.

The current measured value is displayed on the main display.
The leftmost digit of the sub-display flashes.

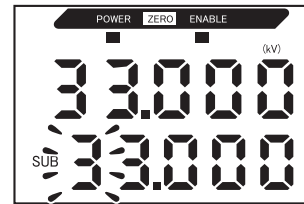
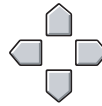

4. Use the cursor keys to set the offset for the measured value.

The decimal point position can be changed as follows.



----- Moves from one digit to another.



----- Changes the numeric value.

5. Press the ENT key to confirm the setting.

The decimal point flashes.



6. Use the LEFT and RIGHT keys to move the decimal point.



7. Press the ENT key to confirm the setting.



Confirming completion of scaling settings

If scaling has been completed correctly, the display indicates [OK].

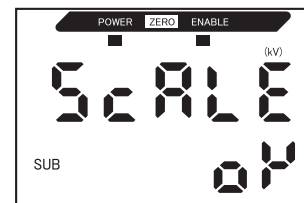

If scaling was not possible, the display indicates [NG].

Check the following points and then execute scaling again.

- Is the ENABLE indicator lit?
- Are the two points separated by at least 1% of the rated measurement range?

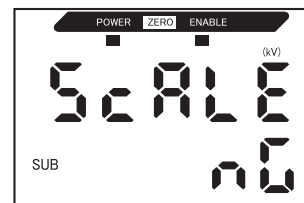

Comparing Measured Values (Differentiation Function)

Use the differentiation function to detect only sudden changes in the measured values that occur during very short periods of time.

The differentiation function detects changes between the present value and the measured value that was active just before the comparing pitch. The coefficient of this comparing pitch is defined as the differentiation cycle.

The relationship between the differentiation cycle and comparing pitch can be calculated by the following equation:

$$\text{Comparing pitch} = \text{differentiation cycle} \times 1 \text{ ms}$$

Example: When differentiation cycle = 10

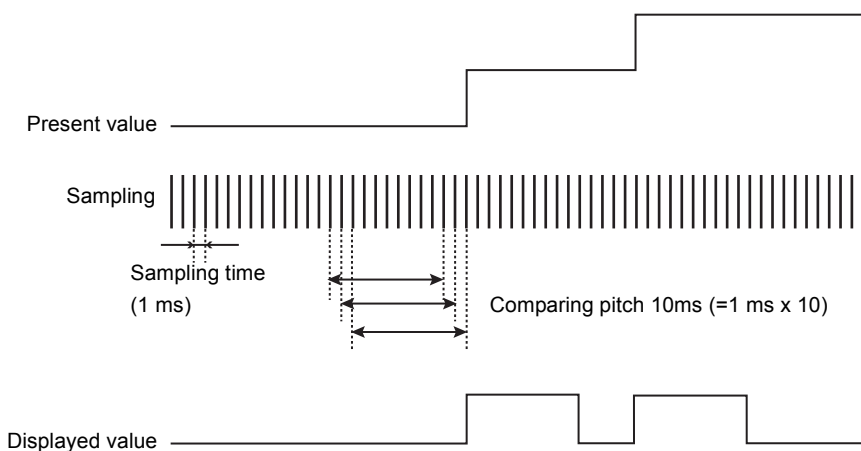

Moving to the FUN mode and SPCL

1. Set the mode switch to FUN.



2. Use the LEFT and RIGHT keys to display [SPCL] on the main display.

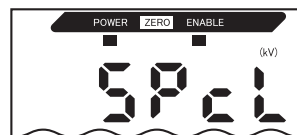

Section 6 Comparing Measured Values (Differentiation Function)

Moving to DIFF

- 3.** Press the UP or DOWN key.
The sub-display flashes.



- 4.** Use the UP and DOWN keys to display [SET] or [ALL].



- 5.** Press the ENT key.



- 6.** Use the LEFT and RIGHT keys to display [DIFF] on the main display.



Moving to the differentiation cycle

- 7.** Press the UP or DOWN key.
The sub-display flashes.



- 8.** Use the UP and DOWN keys to display [ON].



- 9.** Press the ENT key to confirm the setting.
Settings for the differentiation cycle can now be made.



Setting the differentiation cycle

- 10.** Use the LEFT and RIGHT keys to display [D-CYC] on the main display.
[D-CYC] is not displayed if [DIFF] is set to [OFF].

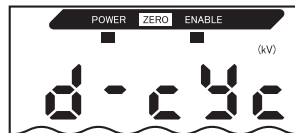

- 11.** Press the UP or DOWN key.
The leftmost digit of the sub-display flashes.



- 12.** Use the cursor keys to set the differentiation cycle.



----- Moves from one digit to another.



----- Changes the numeric value.

- 13.** Press the ENT key to confirm the setting.
This registers the setting.



MEMO

Section 7

APPENDICES

☒ Troubleshooting	110
☒ Error Messages and Countermeasures	111
☒ Q&A	113
☒ Glossary	114
☒ Specifications and Dimensions	115
☒ Communicating with the Static Electricity Smart Monitor via the Interface Unit	124
☒ Characteristic Data	126
☒ Quick Reference for Displays	127
☒ INDEX	131

Troubleshooting

This section describes countermeasures for temporary hardware problems. Check the malfunction in this section before sending the hardware for repair.

Problem	Probable cause and possible countermeasure	Pages
Device restarts during operation.	<ul style="list-style-type: none"> • Is the power supply device connected correctly? • Are the Interface and Calculating Units connected correctly? 	p.23 p.20 p.22
Judgments not output to external devices	<ul style="list-style-type: none"> • Are all cables connected correctly? • Is the signal line disconnected? • Are reset inputs short-circuited? 	p.23
No input signal accepted	<ul style="list-style-type: none"> • Are all cables connected correctly? • Is the signal line disconnected? 	p.23
No communications with personal computer	<ul style="list-style-type: none"> • Is the cable connected correctly? • Is the Interface Unit connected correctly? • Is the switch under the Interface Unit on the side without the tab? • Is the connector pin arrangement correct? 	p.23 p.22 p.124 p.122
Strange linear output levels	<ul style="list-style-type: none"> • Is the switch on the bottom of the Amplifier Unit set to the correct position? • Has the correct selection (voltage/current) been made in the monitor focus settings? • Linear output levels can also be fine-tuned. 	p.70
Nothing displayed on main display or sub-display	Has the number of display digits been set to zero?	p.92
The main display remains at [-----].	<ul style="list-style-type: none"> • Has a timing input been made while hold is enabled and the trigger type has been set to TIMIG? • If the hold function is enabled and the trigger type is [UP] or [DOWN], has the self-trigger level been set to an appropriate value? 	p.53
The measured values fluctuate and are not stable depending on day and time.	A possible cause is the influence of temperature characteristics. Execute zero reset periodically using the standard sensing object to correct this problem.	p.36
Measured values stay fixed and do not change.	<ul style="list-style-type: none"> • Are the reset input and bank shift input short-circuited or ON? • Is the hold function set? 	p.23 p.53

Error Messages and Countermeasures

This section outlines the error messages displayed on the main display and the countermeasures for those messages.

[Errors that occur during regular measurement]

Display	Error	Countermeasure	Pages
E-SHT	One or all of the judgment outputs is short-circuited.	Correct short-circuiting of short-circuited loads. (The sensor is automatically restored after the short-circuited load is canceled.)	p.23
E-EEP	Either EEPROM is damaged or data is in error.	Hold down the ENT key for at least three seconds to clear saved data, and then turn the sensor ON. If this does not solve the error, the Amplifier Unit is malfunctioning. Replace the Amplifier Unit.	p.9
E-HED	The Sensor Head is not connected or the Sensor Head is in error.	Turn OFF the power supply, check the Sensor Head connection, and then turn ON the power supply again. If this does not solve the problem, the Sensor Head is malfunctioning. Replace the Sensor Head.	p.17
ERRLH	An attempt was made to set a numeric value larger than the HIGH threshold to the LOW threshold.	Input correct threshold values.	p.64
	The relationship between threshold values is as follows: HIGH threshold - LOW threshold < hysteresis width.		
ERRHL	An attempt was made to set a numeric value smaller than the LOW threshold to the HIGH threshold.	Input correct threshold values.	p.64
	The relationship between threshold values is as follows: HIGH threshold - LOW threshold < hysteresis width.		
ERROV	The numeric value you are setting is too large.	Input an appropriate numeric value.	p.32
	The relationship between threshold values is as follows: HIGH threshold - LOW threshold < hysteresis width.		
ERRUD	The numeric value you are setting is too small.	Input an appropriate numeric value.	p.32



[Errors that occur during setting of numeric values]

Display	Error	Countermeasure	Pages
ERRLH	An attempt was made to set a numeric value larger than the HIGH threshold to the LOW threshold.	Input correct threshold values.	p.64
	The relationship between threshold values is as follows: HIGH threshold - LOW threshold < hysteresis width.		
ERRHL	An attempt was made to set a numeric value smaller than the LOW threshold to the HIGH threshold.	Input correct threshold values.	p.64
	The relationship between threshold values is as follows: HIGH threshold - LOW threshold < hysteresis width.		
ERROV	The numeric value you are setting is too large.	Input an appropriate numeric value.	p.32
	The relationship between threshold values is as follows: HIGH threshold - LOW threshold < hysteresis width.		
ERRUD	The numeric value you are setting is too small.	Input an appropriate numeric value.	p.32



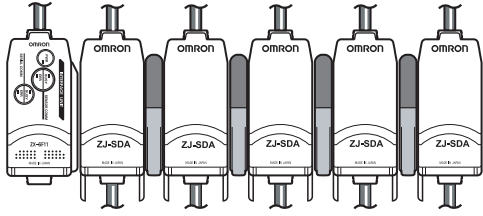

[Errors that occur when an adjacent distance sensor is used]

Display	Error	Countermeasure	Pages
E-DIS	The acquired distance data is in error.	<ul style="list-style-type: none"> • Check that the connected distance sensor is measuring correctly. • Check the connection between the Amplifier Unit and Sensor Head. • When executing area correction, check that the area size setting value is correct. 	p.9 p.17 p.85
E-CH	The Calculating Unit or Amplifier Unit were disconnected with the distance measurement mode set to AUTO.	Check the connection to the connected Amplifier Unit. Or, set the distance measurement mode to USER.	p.17 p.41

Q&A

Question	Answer
What types of Interface Unit can be used?	A ZJ-SF11 is required. A ZX-SF11 compatible with the ZX series cannot be used.
Why does an error occur and settings cannot be made when teaching or directly inputting threshold values?	Threshold values cannot be set using teaching or by direct input if the following condition is not met: • HIGH threshold - LOW threshold value > hysteresis width  p.64
When scaling is executed, an error appears on the sub-display and settings cannot be made.	Scaling cannot be set for one of the following reasons: • Scaling has been attempted when the measured value is outside the measuring range. • When two-point scaling has been executed, the distance between the measured values for the two points is not at least 1 kV of the rated measuring range.  p.99
When monitor focus is executed, why does an error appear on the sub-display and the settings cannot be made?	Monitor focus settings cannot be made when the distance between the two specified points is not at least 1% of the rated measuring range.  p.70
Can calculations be performed with three or more Amplifier Units?	The ZJ-SD does not have a function for calculating measurement results.
Can calculations be performed when Sensor Heads with different measuring ranges are connected to two Amplifier Units?	The ZJ-SD does not have a function for calculating measurement results.
How many Amplifier Units can be connected and communicated with the Interface Unit?	Up to five Amplifier Units can be connected to the ZJ-SDA11. 
Is warm-up operation still required even if bank shift input is cancelled?	No, it is not.

Glossary

Term	Explanation
Response time	Response time is the time from when the sensor measures a charged amount to when the value is output (either as linear output or judgment output). The response time changes depending on the settings for the number of samples to average and calculations.
Measured value	The measured value is the measurement result displayed on the main display of the Amplifier Unit in the RUN or T modes. The measured value is the value after all set processing has been completed, e.g., averaging, scaling, distance correction, area correction, and hold.  p.9
Present value	The present value is the current measurement result obtained by the target Amplifier Unit. Some set processing, such as averaging, scaling, distance correction, and area correction, have been completed for the current measured value, but calculation, and hold, settings are not reflected. To display the present value on the sub-display, press the LEFT or RIGHT key in the RUN mode.  p.9
Linearity	Linearity is defined as the error in an ideal straight line displacement output when measuring the standard sensing object. Linearity shows how closely linear output maintains a linear relationship to the charged amount of the sensing object (i.e., it shows the accuracy of linear output).
Linear output	Linear output is analog data output from the linear output line. Either current or voltage output can be selected. Linear output is made based on the display value and monitor focus settings. The actual value that is output (the output value) can also be displayed on the sub-display by pressing the LEFT or RIGHT key in the RUN mode.  p.70
Judgment outputs	This is a general term for the HIGH, PASS, and LOW outputs. Judgment outputs are made in the RUN or T mode based on the display values and the threshold, hysteresis width, and timer settings.
Measuring range	This is the range (distance) that measurement is possible for the connected Sensor Head.  p.118
Sampling period	Sampling period is the time during which the sensing object is measured when the hold function is being used. The sampling period is determined by the trigger mode and the delay time.  p.53

Specifications and Dimensions

Amplifier Unit
ZJ-SDA11

(Unit: mm)

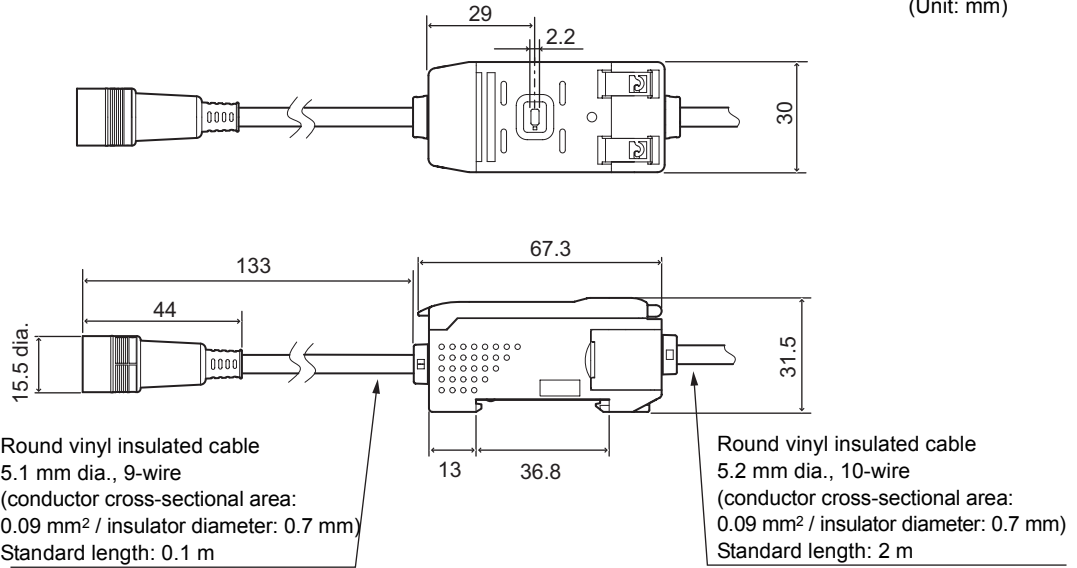

Section 7 Specifications and Dimensions

Item	ZJ-SDA11		
Measurement cycle	1 ms		
Possible settings for number of samples to average (*1)	1, 2, 4, 8, 16, 32, 64, 128, 256, 512, 1024 times		
Temperature characteristics	Static Electricity Sensor Head: 0.01%F.S./°C		
Linear output (*2)	At current output: 4 to 20 mA/F.S, maximum load resistance 300 Ω At voltage output: ±4 V, (±5 V, 1 to 5 V (*3)), output impedance 100 Ω		
Bank shift input	ON: Short-circuited with 0-V terminal or 1.5 V or less OFF: Open (leakage current: 0.1 mA or less)		
Zero reset input			
Timing input			
Reset input			
Function	Measured value display	Initialization	Peak and bottom hold
	Present value display	Teaching function	Mask hold
	Output value display	Direct threshold value setting	Distance trigger
	Setting value display	Hysteresis width setting	Delay hold
	Resolution display	Scaling	Delay time setting
	ENABLE indicator	Monitor focus linear output correction	Timing input
	Zero reset indicator	Peak hold	Clamp value setting
	Judgment indicator	Bottom hold	High-precision measurement mode
	ECO mode	Sample hold	Distance correction function
	Display reverse	Peak-to-peak hold	Detected area correction function
	Display digit limit	Average hold	Warning output function
	Zero reset memory		Bank switching function
	Timers		
Indicators	Operation indicators: OPE1 (orange), OPE2 (green), OPE3 (yellow), 7-segment main display (red), 7-segment sub-display (yellow), zero reset (green), enable (green)		
Power supply voltage	24 VDC ±10%, Ripple (p-p) 10% max.		
Power consumption	3.4 W or less (sensor connected) (at 24 V power supply voltage, current consumption: 140 mA max.)		
Ambient temperature	Operating and storage: 0 to +50°C (with no icing or condensation)		
Ambient humidity	Operating and storage: 35% to 85% (with no condensation)		
Insulation resistance	20 MΩ (at 500 VDC)		
Dialectic strength	1,000 VAC, 50/60 Hz for 1 min		
Vibration resistance (destructive)	10 to 150 Hz, 0.7-mm double amplitude, 80 min each in X, Y, and Z directions		
Shock resistance (destructive)	300 m/s ² 3 times each in 6 directions (up/down, left/right, forward/backward)		
Degree of protection	IP40		
Connection method	Prewired (standard cable length: 2 m)		
Weight (packed state)	Approx. 350 g		
Materials	Case: PBT (polybutylene terephthalate), cover: Polycarbonate		
Accessories	Instruction sheet, ferrite core		

(*1) The response speed of the linear output is calculated as the measurement period x (number of samples to average setting + 1).

The response speed of the judgment outputs is calculated as the measurement period x (number of samples to average setting + 1).

(*2) Current/voltage can be switched using the switch provided on the bottom of the Amplifier Unit.

(*3) Setting is possible via the monitor focus function.

Sensor Head

ZJ-SD100

• Sensor Head

· Angle 1

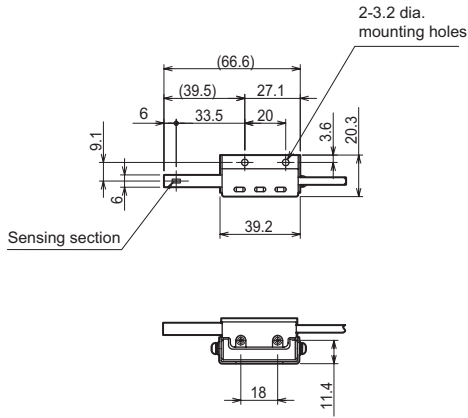

· Angle 2

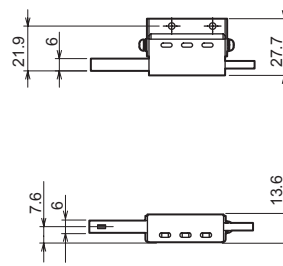

Mount hole dimensions

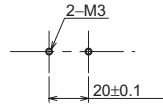

• Preamplifier

· Preamplifier (common to all models)

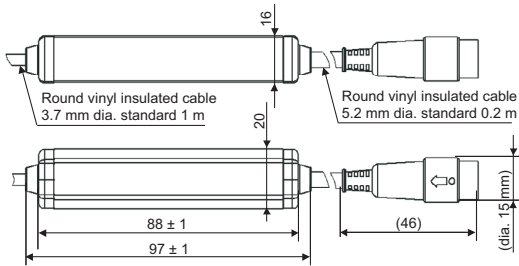

· Preamplifier mounting bracket

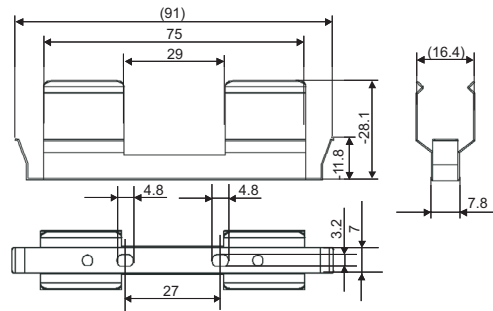

Mount hole dimensions

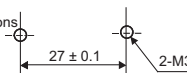

· Preamplifier (when Preamplifier mounting bracket is mounted)

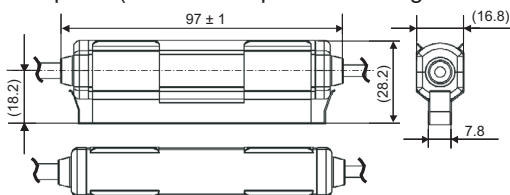

Section 7 Specifications and Dimensions

Item	ZJ-SD100
Applicable Amplifier Unit	ZJ-SDA11
Measurement distance	5 to 100 mm
Max. measurement voltage (*1)	Standard mode: ± 50 KV, high-precision mode: ± 5 KV
Resolution (*2)	Standard mode: 10 KV, high-precision mode: 1 KV
Linearity (*3)	$\pm 5\%$ FS (*4)
Ambient temperature	Operating/storage: 0 to $+50^{\circ}\text{C}$
Ambient humidity	Operating/storage: 35 to 85%
Response time	20 ms
Dialectic strength	1,000 VAC, 50/60 Hz for 1 min (*5)
Vibration resistance	Sensor Head: 10 to 55 Hz, 3-mm double amplitude, 45 min each in X, Y and Z directions Preamplifier: 10 to 55 Hz, 1.5-mm double amplitude, 2 H each in X, Y and Z directions
Degree of protection	IP20
Materials	Sensor Head: SUS Preamplifier: PC
Weight (packed state)	Approx. 150 g
Accessories	Instruction sheet, ferrite core, mounting bracket

- (*1) The measured value is sometimes saturated and correct values are not displayed when the distance to the sensing object is short even if it is inside the measurement voltage range.
- (*2) The minimum value that can be read when an Amplifier Unit (ZJ-SDA11) is connected
- (*3) When the ambient temperature is fixed at 25°C
- (*4) When the measuring distance is 10 mm and measurement voltage is -5 KV to +5 KV
- (*5) In the case of a preamplifier (excluding Sensor Head)

Sensor Head mounting bracket at distance correction
ZJ-XBU1

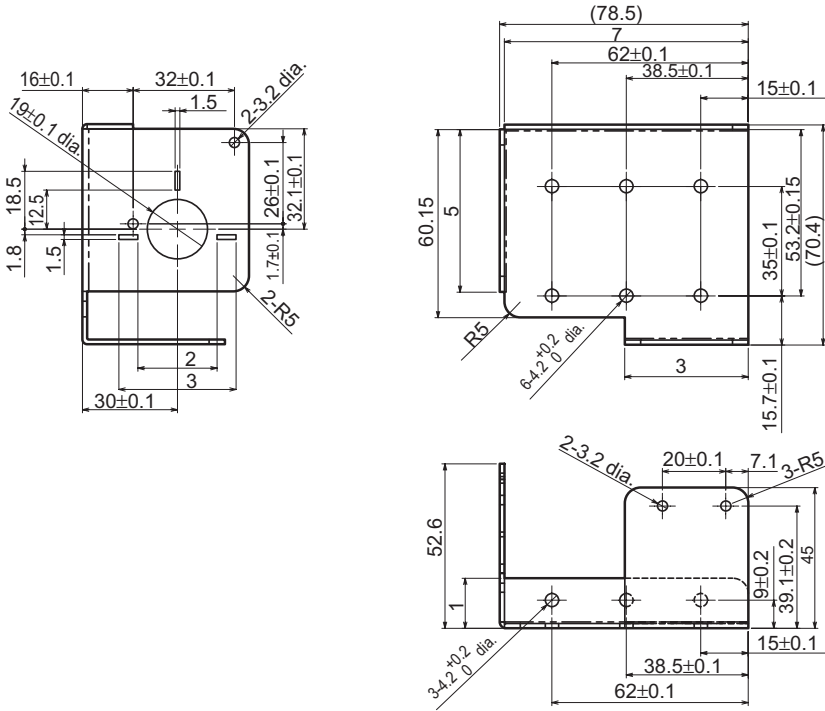

Section 7 Specifications and Dimensions

Dimensions when mounting bracket is mounted on sensor

· When ZJ-S and ZX-LD are mounted

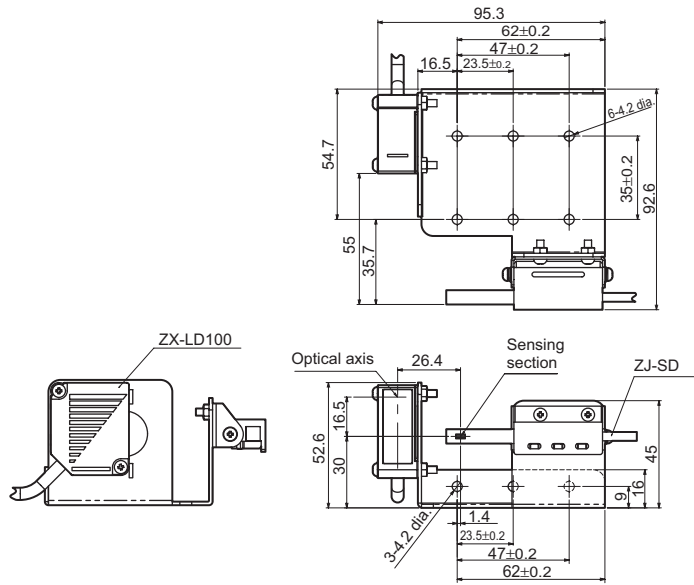

· When ZJ-S and ZX-UD are mounted

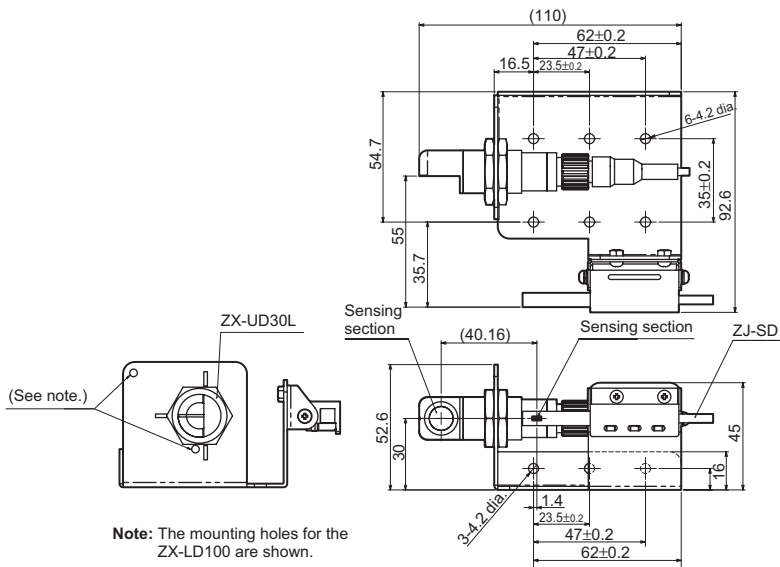

Calculating Unit
ZX-CAL2

(unit: mm)

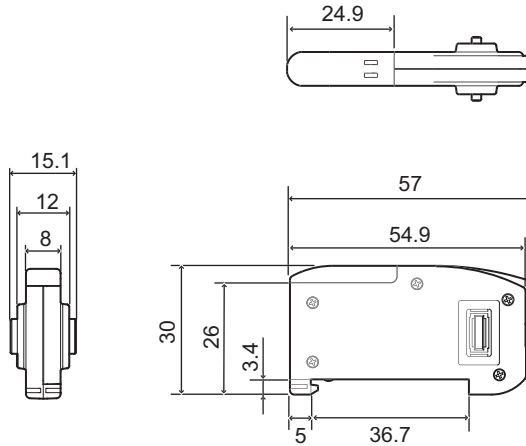

Item	ZX-CAL2
Applicable Amplifier Units	ZX series, ZJ-S series
Current consumption	12 mA or less (supplied from the Amplifier Unit)
Ambient temperature	Operating: 0 to +50°C, Storage: -15 to +60°C (with no icing or condensation)
Ambient humidity	Operating and storage: 35% to 85% (with no condensation)
Connection method	Connector
Dialectic strength	1,000 VAC, 50/60 Hz for 1 min
Insulation resistance	100 MΩ (at 500 VDC)
Vibration resistance (destructive)	10 to 150 Hz, 0.7-mm double amplitude, 80 min each in X, Y, and Z directions
Shock resistance (destructive)	300 m/s ² 3 times each in 6 directions (up/down, left/right, forward/backward)
Materials	Display: Acrylic, Case: ABS resin
Weight (packed state)	Approx. 50 g

Interface Unit
ZJ-SF11

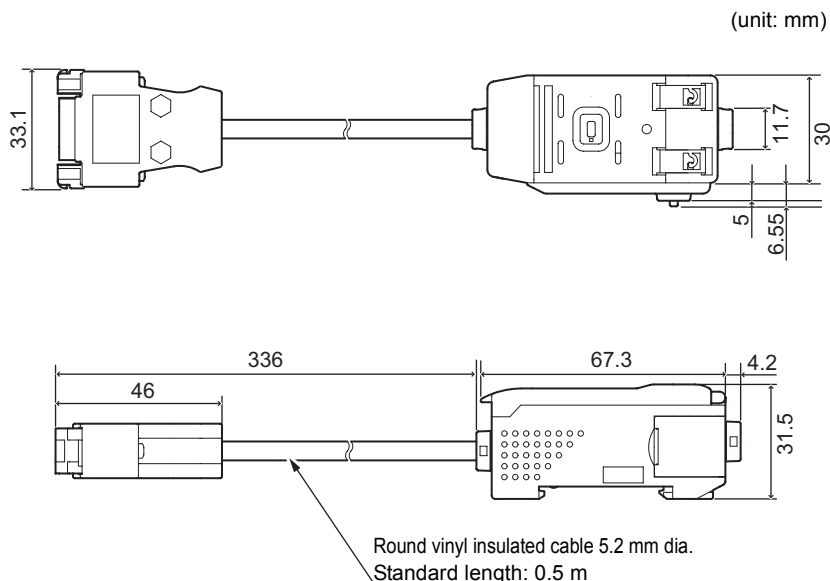

■ Connector Pin Arrangement and Connection Example with Personal Computer

ZJ-SF11 side

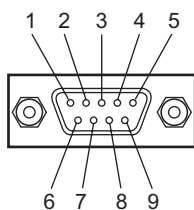

Personal computer side (PC/AT compatible)

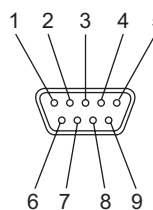

Connect the ZJ-SF11 and the personal computer using a D-sub 9-pin (female-female) cross cable.

Pin No.	Name
1	N.C.
2	RD
3	SD
4	N.C.
5	SG
6	N.C.
7	N.C.
8	N.C.
9	N.C.

Pin No.	Name
1	CD
2	RD
3	SD
4	ER
5	SG
6	DR
7	RS
8	CS
9	CI
Connector hood	FG

* Pin No. may vary with the type and model of the external device to be connected.
For details, refer to the instruction manual of your programmable controller or personal computer.

Item		ZJ-SF11
Power supply voltage		12 to 24 VDC \pm 10%, Ripple (p-p) 10% max. Supplied from Amplifier Unit
Current consumption		At 24 V power supply voltage, 60 mA max. (excluding Amplifier Unit current consumption and output current)
Connectable Amplifier Units		ZJ-S series, ZX series
Number of connectable Amplifier Units		Max. 5 (2 Calculating Units max.)
Communications functions	Communications port	RS-232C port (9-pin D-sub connector)
	Protocol	CompoWay/F
	Baud rate	38,400 bps
	Data configuration	Data bits: 8, Parity: None; Start bits: 1 Stop bits: 1, Flow control: None
Indicators		Power ON (green), Communicating with Sensor (green), Sensor communications error (red) Communicating with external terminal (green), External terminal communications error (red)
Protection circuits		Reverse power supply wiring protection
Ambient temperature		Operating: 0 to +50°C, Storage: -15 to +60°C (with no icing or condensation)
Ambient humidity		Operating and storage: 35% to 85% (with no condensation)
Dialectic strength		1,000 VAC, 50/60 Hz for 1 min
Insulation resistance		20 M Ω min. (at 500 VDC)
Case materials		Case: PBT (polybutylene terephthalate), cover: Polycarbonate
Weight (packed state)		Approx. 350 g

Communicating with the Static Electricity Smart Monitor via the Interface Unit

The following describes the procedure for connecting the Amplifier Unit to a personal computer via an Interface Unit to enable use of the Static Electricity Smart Monitor.

1. Install the Static Electricity Smart Monitor on the personal computer.

2. Check that the current/voltage switch on the base of the Interface Unit is set to the side that has no tab (default).

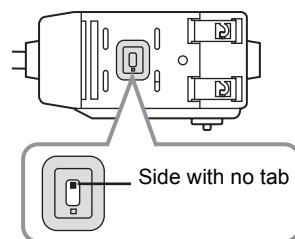

3. Set the Amplifier Unit to the RUN mode.



Switching Modes p.28

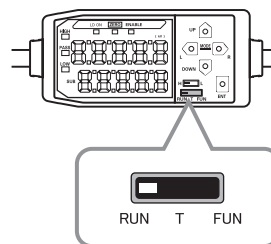

4. Connect the Interface Unit and personal computer with a cable.



To connect to a personal computer (PC/AT compatible), use a 9-pin D-sub cross cable (female to female).
p.122

5. Connect the Interface Unit to the Amplifier Unit.

Use of a calculating unit (ZX-CAL2) allows connection of up to five Amplifier Units.



CHECK!

If you want to connect different types of Amplifier Units, such as ZJ-SDA11 and ZX-E series, contact your OMRON representative.



Connection Method p.22

6. Turn ON the power supply to the Amplifier Unit.

When the Amplifier Unit is powered ON, the Interface Unit will also be powered ON.

When the ERR indicators for the Interface Unit's sensor communication indicator and external terminal communication indicator go out, this indicates that communication is ready. → (Step 7)

If the ERR indicators do not go out even though five seconds or more have elapsed since the power was turned ON, the connections have not been recognized correctly. Check the following points and then turn ON the Amplifier Unit again.

- Is the mode switch on the Amplifier Unit set to [RUN]? → (Step 3)
- Are connections between the Amplifier Units as well as between Amplifier Units and the Interface Unit correct? → (Steps 4, 5)
- Have the Amplifier Units started up correctly? (If they have not started up correctly due to connection failure between Amplifier Units and Sensor Head, eliminate the cause of the error.)

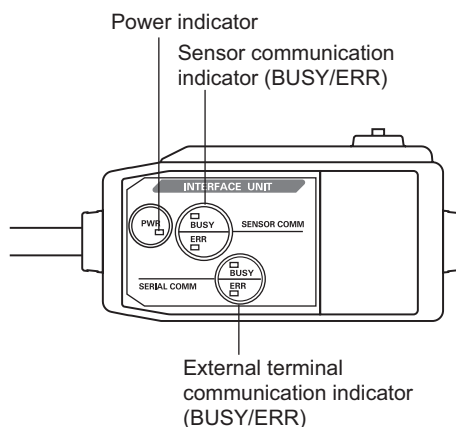

7. Start up the Smart Monitor.

Communication starts automatically.

If communication does not start, turn OFF the Interface Unit and Amplifier Units, and repeat the procedure from step 6.

If communication still does not start, check the following points (i) to (iv), and then restart the Smart Monitor.

- (i) A communication port No. different from that on the personal computer is used or the communication port is used by another application program.
 - Set the same communication port No. as that on the personal computer (the other communication conditions are set automatically).
 - Quit the application program that is using the communication port.
- (ii) The BUSY external terminal communication indicator does not light up when Smart Monitor is started (no signal is being sent to the Interface Unit).
 - Is the Smart Monitor connected with the correct cable? (Check if it is connected with a straight cable by mistake.) → (step 4)
 - Are the connections normal? → (steps 4, 5)
 - Is the correct communication port set?
- (iii) The BUSY external terminal communication indicator lights up for a moment when a command is sent, but there is no response from the Interface Unit.
 - Is the switch on the bottom of the Interface Unit set to the default side? → (step 2)
 - Is the Amplifier Unit set to the RUN mode? → (step 3)
- (iv) An error message appears on the Smart Monitor screen and Smart Monitor cannot start up.
 - Is the Interface Unit in use the correct one? (The dedicated Interface Unit (ZJ-SF11) is required to communicate with ZJ-SDA.)

Characteristic Data

Measurement Voltage-Linearity Characteristics

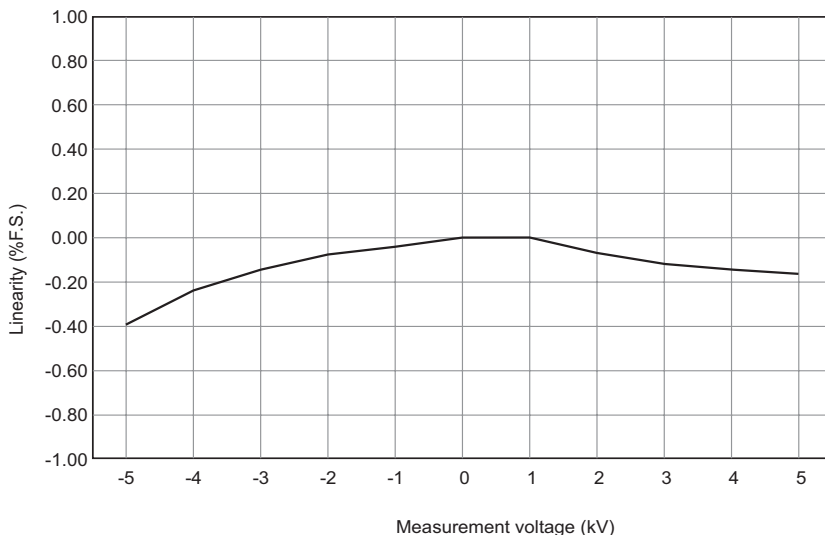

Sensing object: Charging plate (150 x 150 mm, 20 pF)
Measuring distance: 10 mm
Measurement mode: standard

Measuring Distance-Error Characteristics

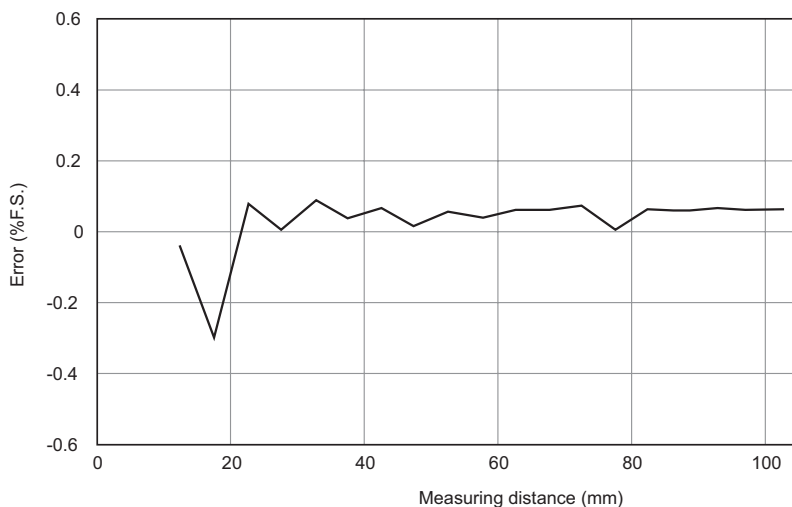

Sensing object: Charging plate (150 x 150 mm, 20 pF)
Measurement voltage: 5 kV
Measurement mode: standard
Measurement after measuring distance is taught to amplifier

Quick Reference for Displays

Using the Quick Reference

Items in the Display column followed by an asterisk (*) appear on the sub-display. All other items appear on the main display.

Display		Details		Pages
1	1-Sht (*)	1-SHT	Timer/One-shot timer	p.80
A	A20mA	A20mA	The meaning of this display item depends on the selected functions. Monitor focus/First point setting (for current output) Linear output correction/First point correction (for current output)	p.70 p.74
	A 4V	A 4V	The meaning of this display item depends on the selected functions. Monitor focus/First point setting (for voltage output) Linear output correction/First point correction (for voltage output)	p.70 p.74
	ALL (*)	ALL	Displays all of the special menu.	p.34
	AREA	AREA	Area correction	p.85
	AUTO (*)	AUTO	Distance measurement mode/Auto	p.42
	AUTOT	AUTOT	T mode/Executing automatic teaching	p.67
	AVE	AVE	Number of samples to average setting	p.52
	AVE-H (*)	AVE-H	Hold/Average hold	p.53
B	B 4mA	B 4mA	The meaning of this display item depends on the selected functions. Monitor focus/Second point setting (for current output) Linear output correction/Second point correction (for current output)	p.70 p.74
	BANK	BANK	Bank selection	p.88
	B 4V	B 4V	The meaning of this display item depends on the selected functions. Monitor focus/Second point setting (for voltage output) Linear output correction/Second point correction (for voltage output)	p.70 p.74
	B-H (*)	B-H	Hold/Bottom hold	p.53
C	CLAMP	CLAMP	Clamp value setting for non-measurement	p.77
	CLAMP (*)	CLAMP	Non-measurement setting/Return output to clamp value	p.77
	CLOSE (*)	CLOSE	Hide special menu	p.35

Section 7 Quick Reference for Displays

	Display		Details	Pages
D	d-cyc	D-CYC	Differentiation function/Differentiation cycle count	p.107
	d-Fwd (*)	D-FWD	Display direction for measured values when scaling function is used (display not inverted)	p.101
	d-Inv (*)	D-INV	Display direction for measured values when scaling function is used (display inverted)	p.101
	dIFF	DIFF	Differentiation function	p.106
	dDIGIT	DIGIT	Number of digits setting for main and sub-displays	p.92
	dDIST	DIST	Distance measurement mode setting	p.42
	dDISP (*)	DISP	Display of display-related functions from special menu	p.92
	dDown (*)	DOWN	Hold/Trigger mode/Self-down trigger	p.58
	dREV	DREV	Reversal of main and sub-displays	p.93
E	ECO	ECO	Reduction of power consumption by darkening main and sub-displays	p.95
	ETC (*)	ETC	Display of functions other than display- and output-related functions from special menu	p.35
F	FOCUS	FOCUS	Measured value output range setting	p.71
	FIX	FIX	FIX mode setting	p.41
H	H-DLY	H-DLY	Hold/Delay hold	p.62
	H-D-T	H-D-T	Hold/Delay hold/Delay time setting	p.63
	H-HYS	H-HYS	Hold/Trigger mode/Self-trigger hysteresis width setting	p.61
	H-LVH	H-LVH	Hold/Trigger mode/Self-trigger level High setting	p.59
	H-LVL	H-LVL	Hold/Trigger mode/Self-trigger level Low setting	p.59
	H-S-T	H-S-T	Hold/Delay hold/Sampling period setting	p.63
	H-TRD	H-TRD	Trigger level or more/Trigger level or less/Within trigger level range	p.59
	H-TRG	H-TRG	Hold/Trigger mode setting	p.56
	hold	HOLD	Hold setting	p.55
	HYS	HYS	Hysteresis width setting	p.69
I	INIT	INIT	Initialization of settings	p.98
K	KEEP (*)	KEEP	Non-measurement settings/Hold output	p.78
L	L-ADJ	L-ADJ	Linear output offset value setting	p.75
M	MASK	MASK	Hold/Mask hold	p.53
	MAX (*)	MAX	Non-measurement settings/Clamp value/Maximum value setting	p.78
	MEAS	MEAS	Measurement mode setting	p.40
O	OFF-D (*)	OFF-D	Timer/Off-delay	p.79
	ON-D (*)	ON-D	Timer/On-delay	p.79
	OUTPT	OUTPT	Output type setting	p.83

Display		Details		Pages
P	P1SCL (*)	P1SCL	Scaling/First point scaling	p.100
	P2SCL (*)	P2SCL	Scaling/Second point scaling	p.103
	Pb-h (*)	PB-H	Hold/Peak and bottom hold	p.53
	P-h (*)	P-H	Hold/Peak hold	p.53
	PP-h (*)	PP-H	Hold/Peak-to-peak hold	p.53
R	rESEt	RESET	Output settings for non-measurement	p.77
	rESEt (*)	RESET	RUN or T mode/Resetting input	p.23
S	S-h (*)	S-H	Hold/Sample hold	p.53
	ScALE	SCALE	Scaling setting	p.99
	S-d IS	S-DIS	Sensor distance value setting	p.43
	SEt (*)	SET	Display of output-related functions from special menu	p.35
	S IEE	SIZE	Area size setting	p.86
	SPcL	SPCL	Special menu Display of scaling, monitor focus, and other special functions	p.35
	StAnd (*)	STAND	Setting of measurement mode to standard mode	p.40
	StAnd (*)	STAND	Setting of output type to standard	p.83
T	t-t iā	T-TIM	Timer time setting	p.81
	t iāEr	TIMER	Judgment output timing setting	p.80
	t iānG (*)	TIMNG	The meaning of this display item depends on the selected mode. FUN mode: Hold/Trigger mode/Timing input RUN or T modes: Input timing	p.56 p.23
U	UP (*)	UP	Hold/Trigger mode/Self-up trigger	p.58
	USEr	USER	User mode setting	p.41
W	YARn	WARN	Output type setting	p.83
	YARn (*)	WARN	Output type/Warning level setting	p.84
Z	ZrāEā	ZRMEM	Setting to save or clear measured values at a zero reset	p.38

MEMO

INDEX

A		ENABLE indicator	9
<hr/>		Error messages	111
F		<hr/>	
Adjusting display brightness	95	FIX mode	41
Alphabet display format	30	Flow of Operation	26
Amplifier Unit		FUN Mode	
Specifications	116	Display Contents	29
Dimensions	115	Function transition	34
Part names	7, 9	Outline	28
Area correction function	85	Function Transition Charts	33
OFF	85	G	
ON	85	<hr/>	
AUTO mode	41	Glossary	114
Automatic teaching	67	GND wire	23
Average hold	54	H	
B		<hr/>	
<hr/>		Hold	
Bank		Mode selection	53
Bank switching	88, 90	Selecting conditions	53
Basic Configuration	6	Hold functions	53
Bottom hold	53	Hysteresis width	59, 69
C		I	
<hr/>		<hr/>	
Calculating Unit		I/O circuit diagrams	24
Connecting	20	Initializing	
Part names	11	Setting data	97
Changing Display Scales	99	Initializing setting data	97
Changing the Number of Display Digits	92	Interface Unit	
Channel numbers	21	Communicating with the Smart Monitor	122
Characteristic data	126	Monitor	124
CLAMP	77	Dimensions	122
CLAMP value	77	Example with Personal Computer	122
Communicating with the Smart Monitor	124	Specifications	123
Correcting Output Values	74	Connecting	22
Current/voltage switch	9	Connector pin arrangement	122
Cursor Keys	30	Part names	12
D		J	
<hr/>		<hr/>	
Default value		Judgment output timing	79
Setting data	97	K	
Delay hold	62	<hr/>	
Differentiation function	105	KEEP	77
Direct input	65	Key lock	
Display reverse	93	Canceling	96
Distance trigger	56	Setting	96
E		Key Lock Function	96
<hr/>		Key operations	30
ECO display function	95	<hr/>	

L

Linear GND wire	23
Linear output	70
Correcting Output Values	74
Linear output wire	23

M

Main Display	29
Mask hold	54
Measured value	114
Mode	28
Switch	28
Switching	28
Monitor focus	70
Mounting bracket	17, 119

N

Non-measurement settings	77
Number of samples to average	52
Numeric Value Changing Method	32

O

OFF-delay timer	79
ON-delay timer	79
One-point scaling	99
One-shot timer	80
Output Cable	23
Output settings	70
Output type	
Standard	82
Warning	82

P

Peak and bottom hold	54
Peak hold	53
Peak-to-peak hold	54
Position teaching	66
Power indicator	9
Power supply wire	23
Preamplifier	
Installation	16
Present value	114

Q

Q&A	113
-----	-----

R

Sensor Head	
Specifications	118
Installing	15

Part names	11
Response time	52, 114
Reversed display	93
RUN Mode	
Display Contents	29
Function transition	33
Outline	28

S

Sample hold	54
Sampling period	53
Self-down trigger	58
Self-up trigger	58
Sensor Head	
Dimensions	117
Specifications	118
Connecting	19
Installing	15
Part names	11
Setting item selection method	31
Setting the Delay Time	62
Specifications	115
Sub-display	29

T

T Mode	
Display Contents	29
Function transition	33
Outline	28
Teaching	64
Threshold	
Switch	9
Threshold values	
Automatic teaching	67
Direct input	65
Entering	64
Position teaching	66
Timer	79
Timing input	56
Timing setting	79
Trigger mode selection	56, 58
Troubleshooting	110
Two-point scaling	103

U

USER mode	41
-----------	----

W

Warning level	
Setting	82
WINDOW	58
Wiring	23

Z

Zero reset Indicator	9
-------------------------	---

MEMO

MEMO

Revision History

A manual revision code appears as a suffix to the catalog number at the bottom of the front and back covers of this manual.

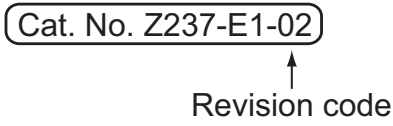

Revision code	Date	Revised contents
01	December 2005	Original production
02	November 2006	Dimensions changed and reference potential compensation function added.

OMRON Corporation
Industrial Automation Company

Sensing Devices Division H.Q.
Application Sensors Division
Shiokoji Horikawa, Shimogyo-ku,
Kyoto, 600-8530 Japan
Tel: (81)75-344-7068/Fax: (81)75-344-7107

Regional Headquarters

OMRON EUROPE B.V.
Sensor Business Unit,
Carl-Benz-Str. 4, D-71154 Nufringen,
Germany
Tel: (49)7032-811-0/Fax: (49)7032-811-199

OMRON ELECTRONICS LLC
1 East Commerce Drive, Schaumburg, IL 60173
U.S.A.
Tel: (1)847-843-7900/Fax: (1)847-843-8568

OMRON ASIA PACIFIC PTE. LTD.
83 Clemenceau Avenue,
#11-01, UE Square,
239920 Singapore
Tel: (65)6835-3011/Fax: (65)6835-2711

OMRON (CHINA) CO., LTD.
Room 2211, Bank of China Tower,
200 Yin Cheng Road (M),
Shanghai, 200120 China
Tel: (86)21-5037-2222/Fax: (86)21-5037-2200

Authorized Distributor: