

M-Vision 1080p-260

**High Brightness Digital Video Projector
16:9 widescreen display**

User Manual



Declaration of Conformity

Directives covered by this Declaration

2004/108/EC Electromagnetic Compatibility Directive.

2006/95/EC Low Voltage Equipment Directive.

Products covered by this Declaration

Large screen video projector type

M-Vision 1080p-260

The CE mark was first applied in:

April 2009

Basis on which Conformity is being declared

The products identified above comply with the protection requirements of the above EU directives, and the manufacturer has applied the following standards.

EN 55022:1998 - Limits and Methods of Measurement of Radio Disturbance Characteristics of Information Technology Equipment.

EN 55024:1998 - Limits and Methods of Measurement of Immunity Characteristics of Information Technology Equipment.

EN 60950-1:2001 - Specification for Safety of Information Technology Equipment, including Electrical Business equipment.

The technical documentation required to demonstrate that the products meet the requirements of the Low Voltage directive has been compiled by the signatory below and is available for inspection by the relevant enforcement authorities.

Signed:



Authority:

D.J. Quinn, Product Development Director

Date:

20 April 2009

Attention!

The attention of the specifier, purchaser, installer, or user is drawn to special measures and limitations to use which must be observed when these products are taken into service to maintain compliance with the above directives. Details of these special measures are available on request, and are also contained in the product manuals.

Important Information

Please read this user manual carefully before using the projector, and keep the manual handy for future reference.

A serial number is located on the back of the projector. Record it here:

Symbols used in this guide

Warnings



ELECTRICAL WARNING: this symbol indicates that there is a danger of electrical shock unless the instructions are closely followed.



WARNING: this symbol indicates that there is a danger of physical injury to yourself and/or damage to the equipment unless the instructions are closely followed.



NOTE: this symbol indicates that there is some important information that you should read.

Trademarks

- IBM is a registered trademark of International Business Machines Corporation.
- Macintosh and PowerBook are registered trademarks of Apple Computer, Inc.
- Other product and company names mentioned in this user's manual may be the trademarks of their respective holders.

Product revision

- Because we at Digital Projection continually strive to improve our products, we may change specifications and designs, and add new features without prior notice. Projectors built prior to this revision of the User Manual may therefore not include all the features described.

Manual revision

Date	Description	Revision
6 May 2010		Rev A

General precautions

Notes



Do not open the cabinet. There are no user serviceable parts inside.

Use only the power cable provided.

Ensure that the power outlet includes a Ground connection, as this equipment **MUST** be earthed.

Take care to prevent small objects such as paper or wire from falling into the projector. If this does happen, switch off immediately, and have the objects removed by authorised service personnel.

Do not expose the projector to rain or moisture, and do not place any liquids on top of the projector.

Unplug before cleaning, and use a damp, not wet, cloth.

Do not touch the power plug with wet hands.

Do not touch the power plug during a thunder storm.

Handle the power cable carefully and avoid sharp bends. Do not use a damaged power cable.



There are no user-serviceable parts inside the lamp module. The whole module should be replaced.

Only lamps supplied by Digital Projection and intended for this projector should be used. Fitting any other lamp could damage both projector and lamp, and will invalidate the warranty.

Take care when removing the lamp module.

NEVER touch the lamp or reflector.

Take care not to touch the glass surface of the lamp module. If you do accidentally touch the glass, it should be cleaned before use. (see section 5. Maintenance.)

Do not use the lamp for more than 2000 hours, as this may cause serious lamp failure, damage the lamp module and cause extra cost on replacement.

HID lamps produce high intensity light. Do not look directly at the light coming from the lamp housing, or the lens, or allow items such as magnifying lenses to be placed in the light path. This could result in serious eye damage.

Do not touch the ventilation outlets, as they will become hot in use.

Do not cover or obstruct the ventilation outlets or inlets.

Do not cover the lens whilst the projector is switched on. This could cause a fire

Always allow the projector to cool for 5 minutes before disconnecting the power, moving the projector or changing the lamp.

Never use strong detergents or solvents such as alcohol or thinners to clean the projector and lens.

Installation precautions



The projector must be installed only by suitably qualified personnel, in accordance with local building codes.

The projector should be installed as close to the power outlet as possible.

The power connection should be easily accessible, so that it can be disconnected in an emergency.

Ensure that there is at least 30cm (12in) of space between the ventilation outlets and any wall, and 10cm (4in) on all other sides.

Do not install the projector close to anything that might be affected by its operational heat, for instance, polystyrene ceiling tiles, curtains etc.

The projector weighs approximately 9 kg (20 lbs). Use safe handling techniques when lifting the projector.

Do not stack more than three projectors.

When stacking projectors, the stack **MUST** be vertical, to ensure that the stresses are distributed to all four chassis corners.

Before installation, make sure that the surface, ceiling or rigging that is to support the projector is capable of supporting the combined weight of all the projectors.

Backup safety chains or wires should always be used with ceiling mount installations.

Do not place heavy objects on top of the projector chassis. Only the chassis corners are capable of withstanding the weight of another projector.

Do not drop or knock the projector.

Place the projector in a dry area away from sources of dust, moisture, steam, smoke, sunlight or heat.

Do not tilt the projector more than $\pm 12^\circ$ in either direction when in use, as this may cause serious lamp failure, damage the lamp module and cause extra cost on replacement.

Operation and configuration precautions



Software update should **NOT** be carried out except by, or with the supervision of, Digital Projection Service personnel.

Notes

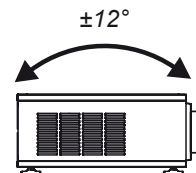
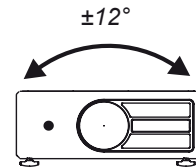

Compliance with international standards

Notes

Noise

GSGV Acoustic Noise Information Ordinance

The sound pressure level is less than 35 dB (A) according to ISO 3744 or ISO 7779.

RF Interference

FCC

The Federal Communications Commission does not allow any modifications or changes to the unit EXCEPT those specified by Digital Projection in this manual. Failure to comply with this government regulation could void your right to operate this equipment.

This equipment has been tested and found to comply with the limits for a Class B digital device, pursuant with Part 15 of the FCC Rules. These limits are designed to provide reasonable protection against harmful interference when the equipment is operated in a residential environment. This equipment generates, uses, and can radiate radio frequency energy and, if not installed and used in accordance with the instruction manual, may cause harmful interference to radio communications.

European Waste Electrical and Electronic Equipment (WEEE) Directive



Digital Projection Ltd is fully committed to minimising Waste Electrical and Electronic Equipment. Our products are designed with reuse, recycling and recovery of all components in mind. To this end, at end of life, your projector may be returned to Digital Projection Ltd or its agent so that the environmental impact can be minimised.

Digital Projection Contact details

Digital Projection Limited,

Greenside Way, Middleton, Manchester M24 1XX, UK.

Registered in England No. 2207264, Registered Office: as above

Tel +44 (0) 161 947 3300

Fax +44 (0) 161 684 7674

Email enquiries@digitalprojection.co.uk, service@digitalprojection.co.uk

Web Site www.digitalprojection.co.uk

Digital Projection Inc.

55 Chastain Road, Suite 115, Kennesaw, GA 30144. USA

Tel (USA) 770 420 1350

Fax (USA) 770 420 1360

Email powerinfo@digitalprojection.com

Web Site www.digitalprojection.com

Notes

M-Vision 1080p-260 User Manual

Contents

Declaration of Conformity	iii
Important Information	
Symbols used in this guide	v
Warnings.....	v
Trademarks.....	v
Product revision	v
Manual revision	v
General precautions	vi
Installation precautions	vii
Operation and configuration precautions	vii
Compliance with international standards	viii
Noise.....	viii
RF Interference.....	viii
European Waste Electrical and Electronic Equipment (WEEE) Directive	viii
Digital Projection Contact details	ix
1. Introduction	
What's in the box?	1.2
Key features of the projector	1.3
Getting to know the projector	1.4
Front view	1.4
Rear view.....	1.4
2. Installation	
Screen requirements	2.2
Aspect ratio.....	2.2
Positioning the screen and projector	2.6
Screen size vs throw distance	2.7
Shifting the image	2.10
Mounting the projector	2.11
Ceiling mounting.....	2.11
Level adjustment.....	2.11
Rear projection	2.12
Stacking projectors	2.12

continued

Connecting the projector	2.13
Signal Inputs	2.13
Control connections	2.15
Power connection	2.16
3. Getting Started	
Positioning the screen and projector	3.2
Switching the projector on	3.2
Inserting batteries into the remote control	3.2
Selecting an input signal or test pattern	3.3
Input	3.3
Test pattern	3.3
Adjusting the lens	3.3
Zoom	3.3
Focus	3.3
Shift	3.3
Adjusting the projected image	3.4
Aspect ratio	3.4
Image quality settings	3.4
Switching the projector off	3.4
4. Controlling the projector	
Overview	4.3
Controlling the projector	4.3
The control panel	4.4
LED status indicators	4.4
The remote control	4.5
Layout	4.5
Timeout	4.5
Using the control keys	4.6
Power	4.6
Source	4.6
Aspect ratio	4.6
User memory	4.6
Image quality settings	4.7
Test pattern	4.7
Using the menus	4.8
Navigating menus and submenus	4.8

continued

Main menu	4.9
Aspect Ratio	4.9
Presets	4.10
Brightness	4.11
Contrast	4.11
Saturation	4.11
Hue	4.11
Sharpness	4.12
Noise Reduction	4.12
Overscan	4.12
Input Select	4.13
Resync	4.13
Advanced menu	4.14
Colour Space	4.14
Video Standard	4.15
Gamma	4.15
Colour Temperature	4.15
Colour Gamut	4.16
Brilliant Color®	4.16
Adaptive Contrast	4.16
RGB Adjust	4.17
Fine Sync	4.18
System menu	4.19
Language	4.19
Source Enable	4.20
Menu Position	4.21
Blank Screen	4.21
Auto Power On	4.21
Auto Power Off	4.21
Rear Projection	4.22
Ceiling Mode	4.22
Logo Display	4.22
Control menu	4.23
Trigger 1 & 2	4.23
Auto Source	4.24
Keys 1 to 5	4.24
Service menu	4.25
Factory Reset	4.25
Blue Only	4.26
Test Patterns	4.26
Altitude	4.26

continued

5. Maintenance

Changing the lamp module 5.2

Cleaning the fans 5.3

6. Appendix

Troubleshooting 6.2

 Error codes 6.4

Specifications 6.5

 Part numbers 6.5

 Optical 6.5

 Electrical 6.6

 Physical 6.6

Dimensions 6.7

Video formats supported 6.8

Input connections 6.10

 HDMI 1 & 2 inputs 6.10

 Composite video input 6.10

 S-Video input 6.10

 RGB input 6.11

 Component 1 input 6.11

 Component 2 input 6.11

Control connections 6.12

 Wired Remote control connection 6.12

 Trigger 1 & 2 output 6.12

 Serial control input 6.12

Remote communications protocol 6.13

 Introduction 6.13

 Key Commands 6.13

 Operation Commands 6.15

1. Introduction

Contents

What's in the box?	1.2
Key features of the projector	1.3
Getting to know the projector	1.4
Front view	1.4
Rear view.....	1.4

What's in the box?

- Make sure your box contains everything listed. If any pieces are missing, contact your dealer.
- You should save the original box and packing materials, in case you ever need to ship your Projector.



Projector
 (0.73:1 fixed lens 109-729
 1.56–1.86:1 zoom lens 109-658
 1.85–2.40:1 zoom lens 109-680)

Notes

 For more detailed information about lenses, see **Screen size vs throw distance**, in section **2. Installation**.

 Only one power cable - dependent on the destination territory - will be supplied with the projector.

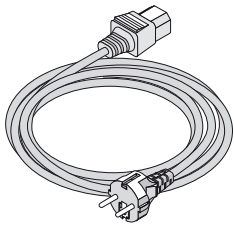

Power cable 10A
 Europe
 (102-163)

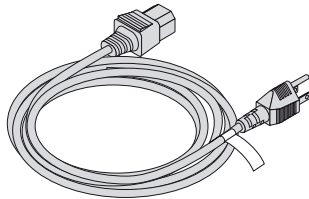

Power cable 13A
 North America
 (102-165)

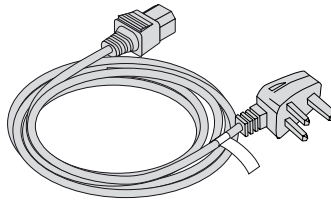

Power cable 10A
 United Kingdom
 (102-180)

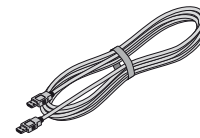

HDMI cable

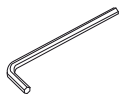

5mm Allen wrench

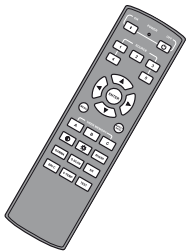

Remote control
 (109-685)



2x AA batteries

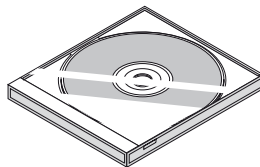

User manual on CD
 (110-288)

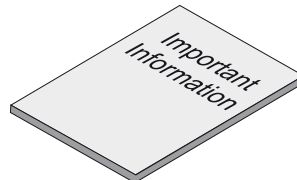

Important Information
 (110-287)



Getting Started Guide
 (110-286)

Key features of the projector

Congratulations on your purchase of the Digital Projection M-Vision 1080p 260 projector.

Digital Projection International (DPI), Texas Instruments' first DLP® partner and the original innovator of the 3-chip DLP® projector, proudly introduces the new M-Vision 1080p-260, a high brightness 1080p platform with the imaging fidelity of Texas Instruments' DLP® technology. The single chip M-Vision 260 adds a remarkably affordable, high-lumen line of 1920 x 1080 displays to DPI's already extensive single-chip product line.

The imagery benefits associated with the M-Vision are plentiful, including an expanded color gamut range and bold 3500 lumens. For any commercial venue, including those contending with high ambient light, the 260 offers bright, saturated color. Augmenting these benefits is the incredible efficiency of the single lamp, meaning the 260 produces the beautiful imagery while consuming a fraction of the wattage of similar products. Installation is incredibly flexible due to the M-Vision's compact and lightweight chassis design, and extraordinary lens shift range of 30% horizontal and 120% vertical. Multiple lens options provide further flexibility, with a throw range from .73 to 2.40:1.

Providing a bright, saturated image from a small-form single-chip display, the M-Vision 1080p-260 presents a powerful yet remarkably affordable solution for a variety of commercial and home entertainment applications, including media rooms and home theaters, training and education, boardrooms and conference centers, visualization/simulation environments, retail, entertainment, digital media/advertising and hospitality.

Key Features

- High resolution projector for medium sized venues
- Applications: Medium sized Screen; Fixed install and Rental
- Brightness 3500 ANSI lumens $\pm 10\%$
- Contrast 2000:1 $\pm 10\%$
- 1920 x 1080 resolution
- Precision mechanical design ensuring maximum amount of light from lamp housing reaches optics, without any operator adjustment
- 350W single phase, 100-240VAC $\pm 10\%$
- Compact size, light weight - approximately 9 kg (20 lbs)
- Robust metal case
- RS232 connection for remote operation using control codes
- Seven selectable Digital and Analogue Video inputs for display of the latest as well as legacy video standards.
HDMI, RGBHV, Component, S-Video, Composite all as standard
- IR remote control for easy setup

Notes

Getting to know the projector

Front view

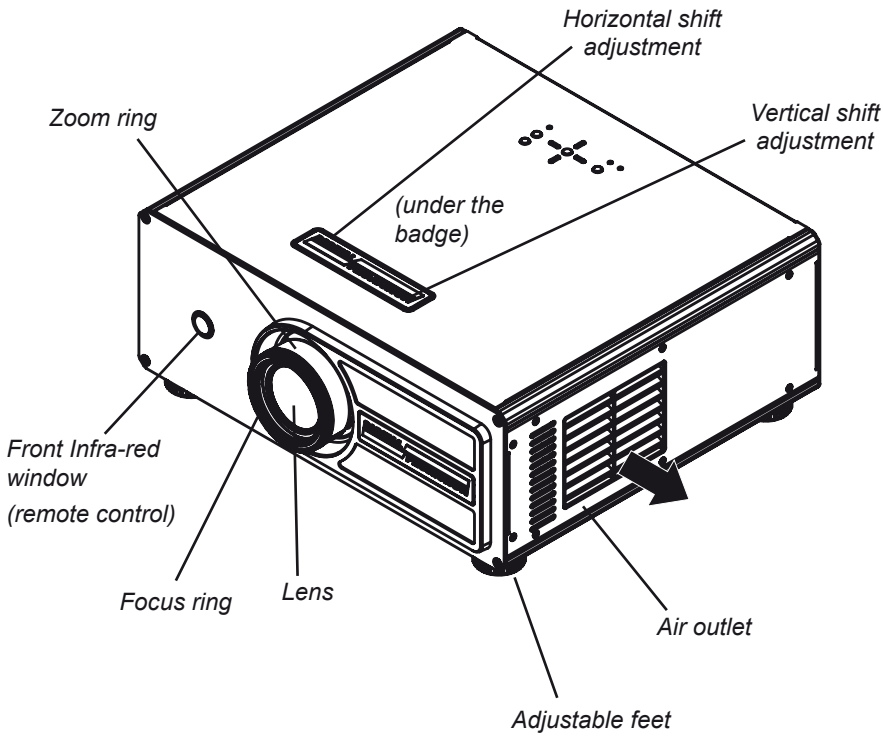

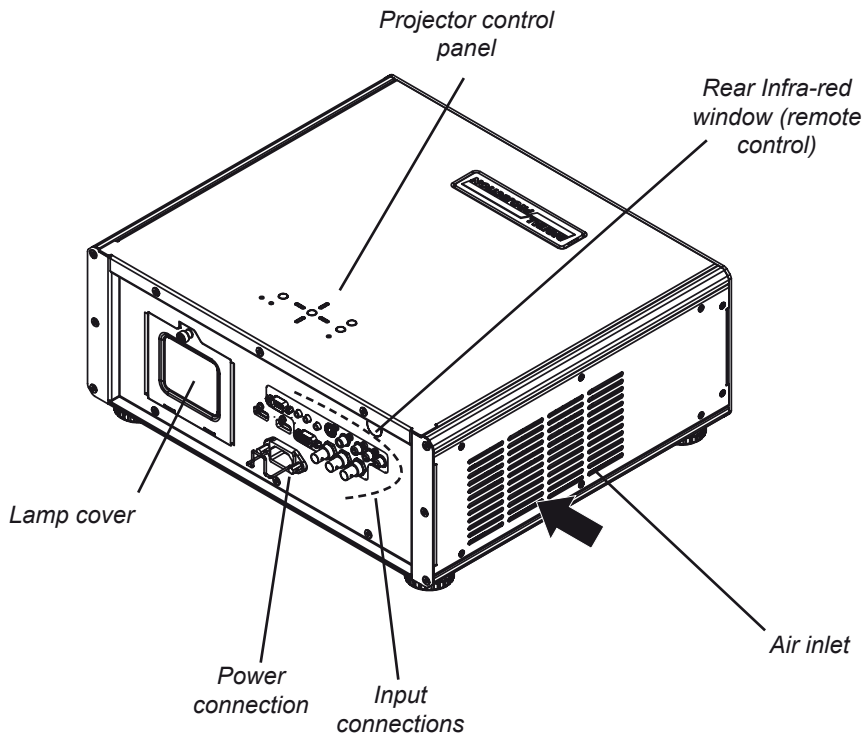

Rear view



Notes

 For more detailed information about lenses or lens shift, see **section 2. Installation**

 For information about how to change the lamp or the filter, see **section 5. Maintenance**.

 For information about controls and indicators, see **section 4. Controlling the projector**.

2. Installation

Contents

Screen requirements	2.2
Aspect ratio	2.2
<i>Fitting the image to the DMD</i>	2.2
<i>Examples of 16:9 images displayed with different aspect ratio settings</i>	2.2
<i>Examples of 4:3 images displayed with different aspect ratio settings</i>	2.3
<i>Examples of 2.35:1 images displayed with different aspect ratio settings</i>	2.3
<i>Diagonal screen sizes</i>	2.4
<i>Fitting the image to the screen</i>	2.5
Positioning the screen and projector	2.6
<i>Optimum viewing position</i>	2.6
Screen size vs throw distance	2.7
<i>Calculating screen width and throw distance</i>	2.7
<i>Lens charts for the short throw zoom lens</i>	2.8
<i>example</i>	2.8
<i>Lens charts for the long throw zoom lens</i>	2.9
<i>example</i>	2.9
Shifting the image	2.10
Mounting the projector	2.11
Ceiling mounting	2.11
Level adjustment	2.11
Rear projection	2.12
Stacking projectors	2.12
Connecting the projector	2.13
Signal Inputs	2.13
<i>Input connection examples</i>	2.13
Control connections	2.15
<i>Remote control</i>	2.15
<i>RS232 connection</i>	2.15
<i>Trigger 1 & 2</i>	2.15
Power connection	2.16

Screen requirements

Aspect ratio

Fitting the image to the DMD

The projector uses a DMD (Digital Mirror Device) to create the image that is projected onto the screen. The resolution of the DMD in this projector is 1920 x 1080 pixels, or to put it another way, its aspect ratio is 16:9.

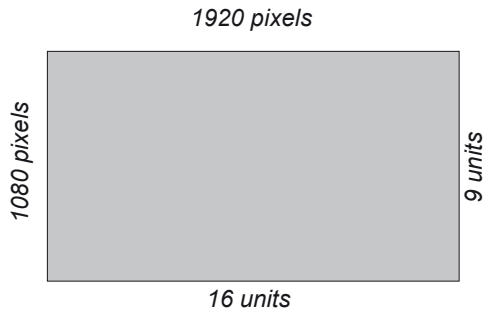

If the source image supplied to the projector has a different aspect ratio from this, or even if it has the same aspect ratio but fewer pixels, then the image will not fill the DMD. The projector therefore needs to scale the image.

The projector has five aspect ratio settings, so that you can choose the one that is most suitable for your image source. The settings are:

- 16:9** the image is scaled to fill the DMD (and thus, a 16:9 screen).
- Theaterscope** the image is scaled such that a 2.35:1 image will be displayed at the correct aspect ratio when the projector is fitted with an anamorphic lens. Thus an image with an aspect ratio of 2.35:1 can be displayed using the full 16:9 resolution of the DMD.
- 4:3** the image is scaled to fit a 4:3 screen, using the full height of the DMD.
- 4:3 Narrow** to be used for 4:3 images in combination with an anamorphic lens. The image is scaled to fit the DMD vertically, but squeezed horizontally such that the lens will stretch it to the correct ratio.
- Native** the image is displayed with no scaling, at its original resolution, in the centre of the screen.

Examples of 16:9 images displayed with different aspect ratio settings

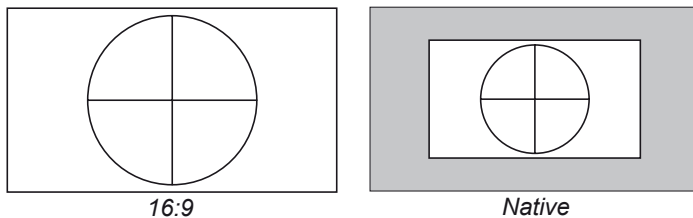

Note that, as the aspect ratio of the image matches that of the DMD, the 16:9 setting is best, unless there is some specific reason for wanting the smaller image, for instance, to maintain the same scale as other images from the same source.

Notes

 For more information about changing the **Aspect ratio** setting, see **Using the control keys and Using the menus in section 4. Controlling the Projector.**

 The 16:9 image shown here has far fewer pixels than the 1920 x 1080 of the DMD. Your image may be different.

Examples of 4:3 images displayed with different aspect ratio settings

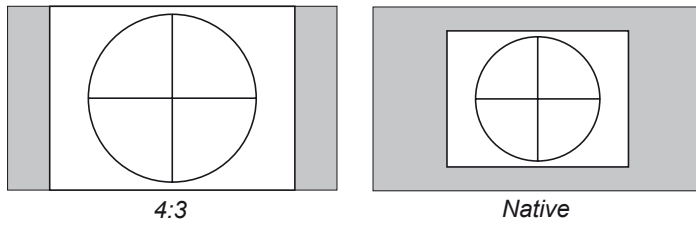

The 4:3 setting is best, unless there is some specific reason for wanting the smaller Native image, for instance, to maintain the same scale as other images from the same source.

If you are using an anamorphic lens, the 4:3 Narrow setting should be used. The lens will stretch the image to the correct width.

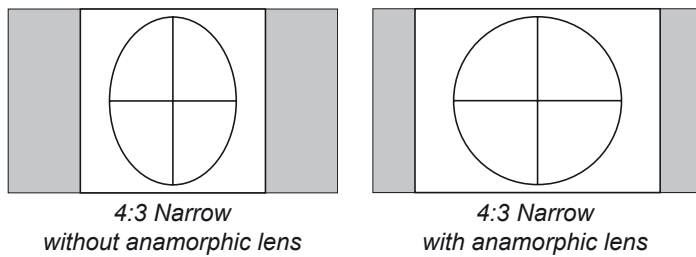

Examples of 2.35:1 images displayed with different aspect ratio settings

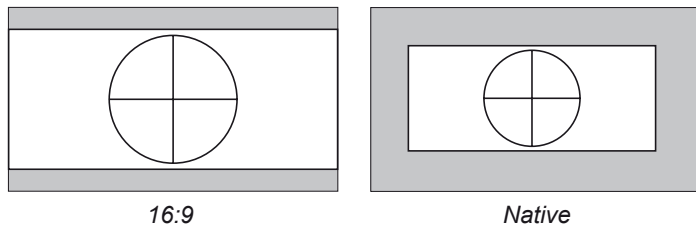

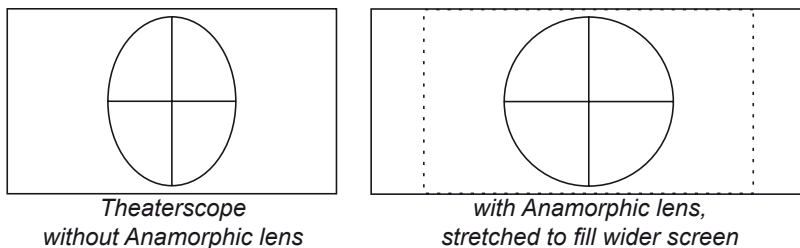

The 16:9 setting is best, unless there is some specific reason for wanting the smaller Native image, for instance, to maintain the same scale as other images from the same source.

If you have an anamorphic lens, the Theaterscope setting would be a much better option. Because it uses the whole of the DMD, it will be a much brighter image than the letterboxed options shown above, and will fill a wider screen if this is available.



Notes

 The 4:3 image shown here has far fewer pixels than the 1920 x 1080 of the DMD. Your image may be different.

 If you are using an anamorphic lens, you will need to use the 4:3 Narrow setting to correct the image.

 The 2.35 image shown here has far fewer pixels than the 1920 x 1080 of the DMD. Your image may be different.

 To take advantage of the Theaterscope setting, you MUST have an anamorphic lens.

Diagonal screen sizes

Screen sizes are sometimes specified by their diagonal size (D) in inches. When dealing with large screens and projection distances at different aspect ratios, it is more convenient to measure screen width (W) and height (H).

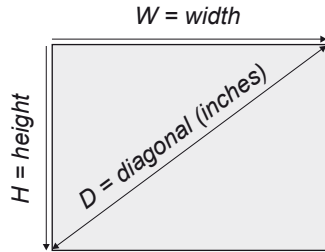

The example calculations below show how to convert diagonal sizes in inches into width and height, at various aspect ratios.

2.35:1 (Scope)

$$W = D \times 0.92\text{in} \quad (D \times .023\text{m}) \quad H = D \times 0.39\text{in} \quad (D \times .01\text{m})$$

1.85:1

$$W = D \times 0.88\text{in} \quad (D \times .022\text{m}) \quad H = D \times 0.47\text{in} \quad (D \times .012\text{m})$$

16:9 = 1.78:1 (native aspect ratio)

$$W = D \times 0.87\text{in} \quad (D \times .022\text{m}) \quad H = D \times 0.49\text{in} \quad (D \times .0125\text{m})$$

1.66:1 (Vista)

$$W = D \times 0.86\text{in} \quad (D \times .022\text{m}) \quad H = D \times 0.52\text{in} \quad (D \times .013\text{m})$$

16:10 = 1.6:1

$$W = D \times 0.85\text{in} \quad (D \times .022\text{m}) \quad H = D \times 0.53\text{in} \quad (D \times .014\text{m})$$

4:3 = 1.33:1

$$W = D \times 0.8\text{in} \quad (D \times .02\text{m}) \quad H = D \times 0.6\text{in} \quad (D \times .015\text{m})$$

Notes

Fitting the image to the screen

It is important that your screen is of sufficient height and width to display images at all the aspect ratios you are planning to use.

Use the conversion chart, or the sample calculations below to check that you are able to display the full image on your screen. If you have insufficient height or width, you will have to reduce the overall image size in order to display the full image on your screen.

Notes

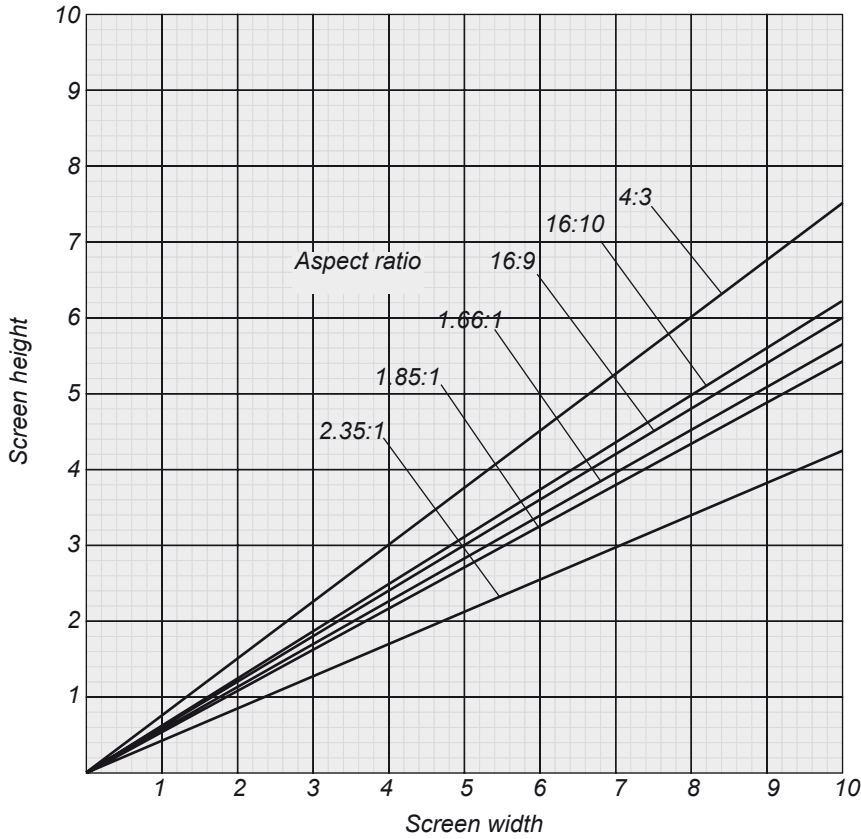

2.35:1 (Scope)

$W = H \times 2.35$ $H = W \times 0.426$

1.85:1

$W = H \times 1.85$ $H = W \times 0.54$

16:9 = 1.78:1 (native aspect ratio)

$W = H \times 1.78$ $H = W \times 0.56$

1.66:1 (Vista)

$W = H \times 1.66$ $H = W \times 0.6$

16:10 = 1.6:1

$W = H \times 1.6$ $H = W \times 0.625$

4:3 = 1.33:1

$W = H \times 1.33$ $H = W \times 0.75$

Positioning the screen and projector

Optimum viewing position

For optimum viewing, the screen should be a flat surface perpendicular to the floor. The bottom of the screen should be 1.2m (4 feet) above the floor and the front row of the audience should not have to look up more than 30° to see the top of the screen.

The distance between the front row of the audience and the screen should be at least twice the screen height and the distance between the back row and the screen should be a maximum of 8 times the screen height. The screen viewing area should be within a 60° range from the face of the screen.

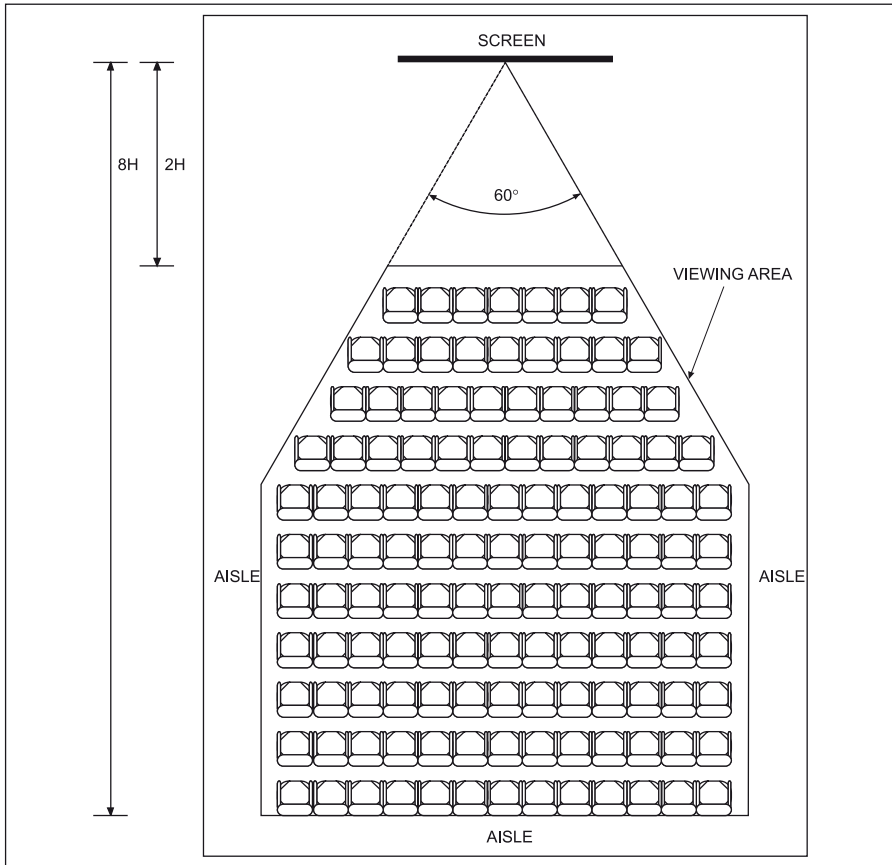
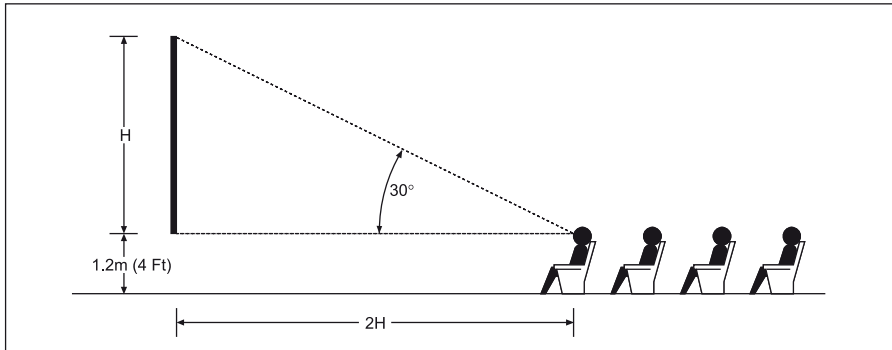

Notes



The projector should be installed as close to the power outlet as possible.

The power connection should be easily accessible, so that it can be disconnected in an emergency.

Ensure that there is at least 30cm (12in) of space between the ventilation outlets and any wall, and 10cm (4in) on all other sides.

Do not install the projector close to anything that might be affected by its operational heat, for instance, polystyrene ceiling tiles, curtains etc.



The image can be flipped for rear projection (see section 4. Using the menus, Image menu) and displayed without the need for extra mirrors or equipment.

However, you must ensure that there is sufficient distance behind the screen for the projector to be correctly located.

Rear installation is generally more complicated and advice should be sought from your local dealer before attempting it.

Screen size vs throw distance

Throw distance is the distance measured from the front of the projector to the screen. This is an important calculation in any projector installation as it determines whether or not you have enough room to install your projector with the desired screen size, and if your image will be the right size for your screen.

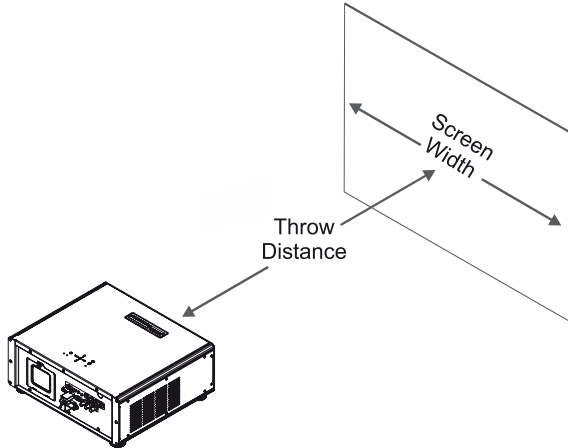

Calculating screen width and throw distance

$$\text{Throw Distance} = \text{Screen Width} \times \text{Lens Throw Ratio}$$

$$\text{Screen Width} = \frac{\text{Throw Distance}}{\text{Lens Throw Ratio}}$$

Three models of the projector are available, fitted with the following lenses:

	<i>Throw Ratio</i>	<i>Focus range</i>
• Fixed lens	0.73:1	to be confirmed
• Short-throw lens	1.56–1.86:1 zoom	2–7m (6.6 - 23ft)
• Long-throw lens	1.85–2.40:1 zoom	2.5–10m (8.2 - 32.8ft)

Two optional converter lenses are available, which modify the throw ratios as shown below:

	<i>0.8x converter</i>	<i>1.25x converter</i>
• Short-throw lens	1.25–1.49:1	1.95–2.33:1
• Long-throw lens	1.48–1.92:1	2.31–3:1

These throw ratios are correct for images that full the full width of the DMD. For images that do not fill the full width, the throw ratio will be larger. For 4:3 images, the throw ratio is increased by a factor of 1.33. The effect of this can be seen on the lens charts on the following pages.

Notes

 For more information about the relationship between screen size, throw distance and converter lenses, see the **Lens charts** on the following pages.

 Do not confuse the focus range with the zoom range:

- the focus range is the distance over which the image can be focused using the focus ring.

- the zoom range is the range over which the throw ratio can be changed using the zoom ring.

 The converter lens is not physically compatible with the Fixed lens.

Lens charts for the short throw zoom lens

Notes

example

- You can display a 16:9 image with a screen width of 3m at a distance of 5m, but for a screen width of 3.5m, you will need to use the 0.8x converter lens.

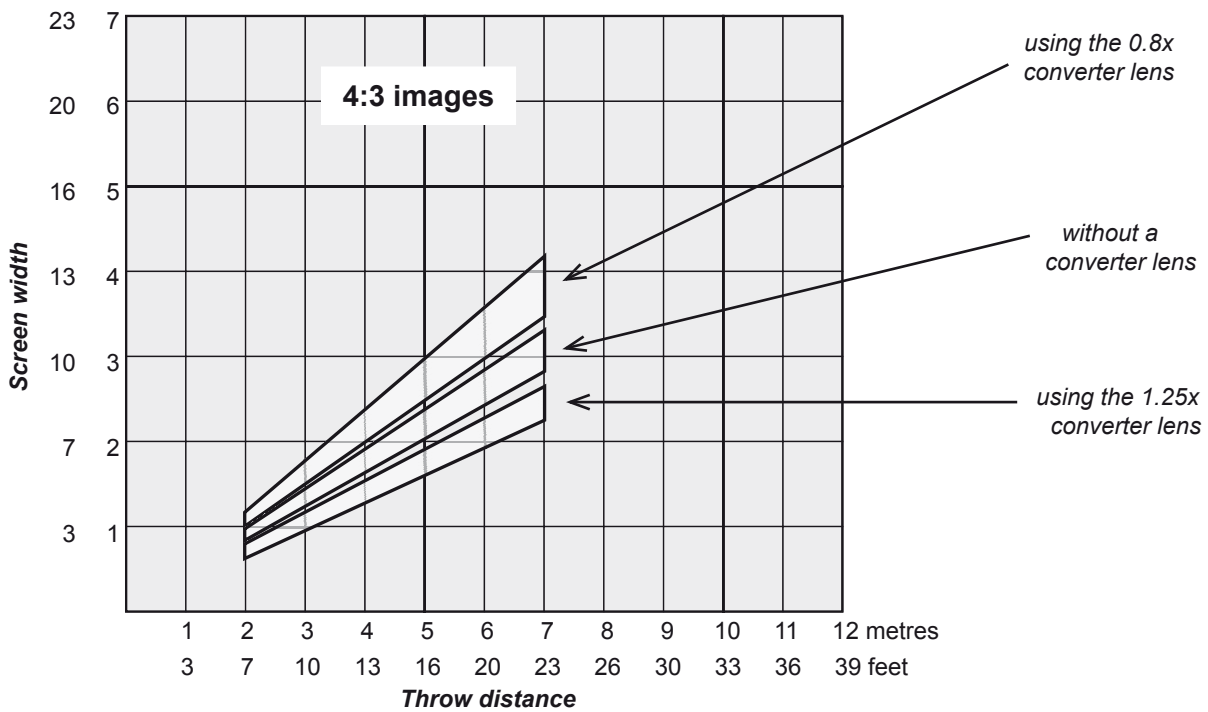
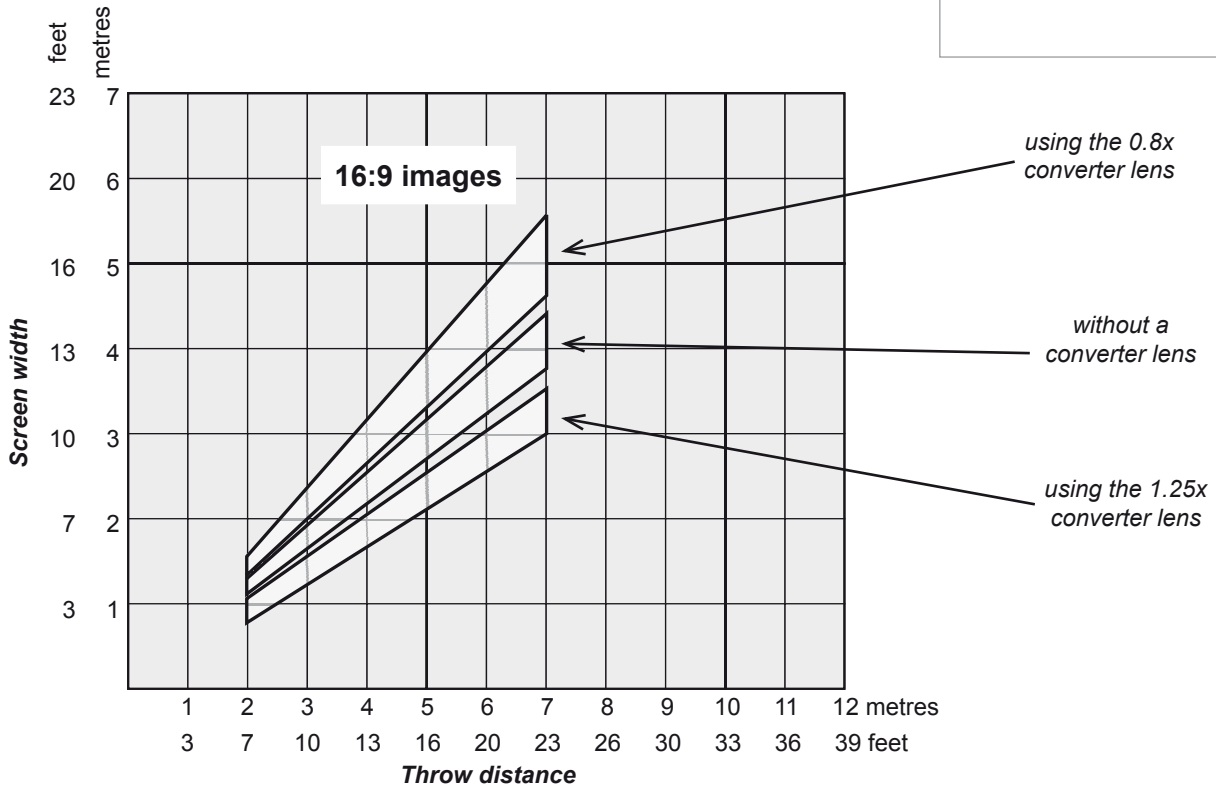

Lens charts for the long throw zoom lens

example

- You can display a 4:3 image with a screen width of 3m at a distance of 6m, but for a screen width of 2m, you will need to use the 1.25x converter lens.

Notes

 Note that for the long throw lens, there is some overlap between the range available using the converter lenses and that using no converter lens.

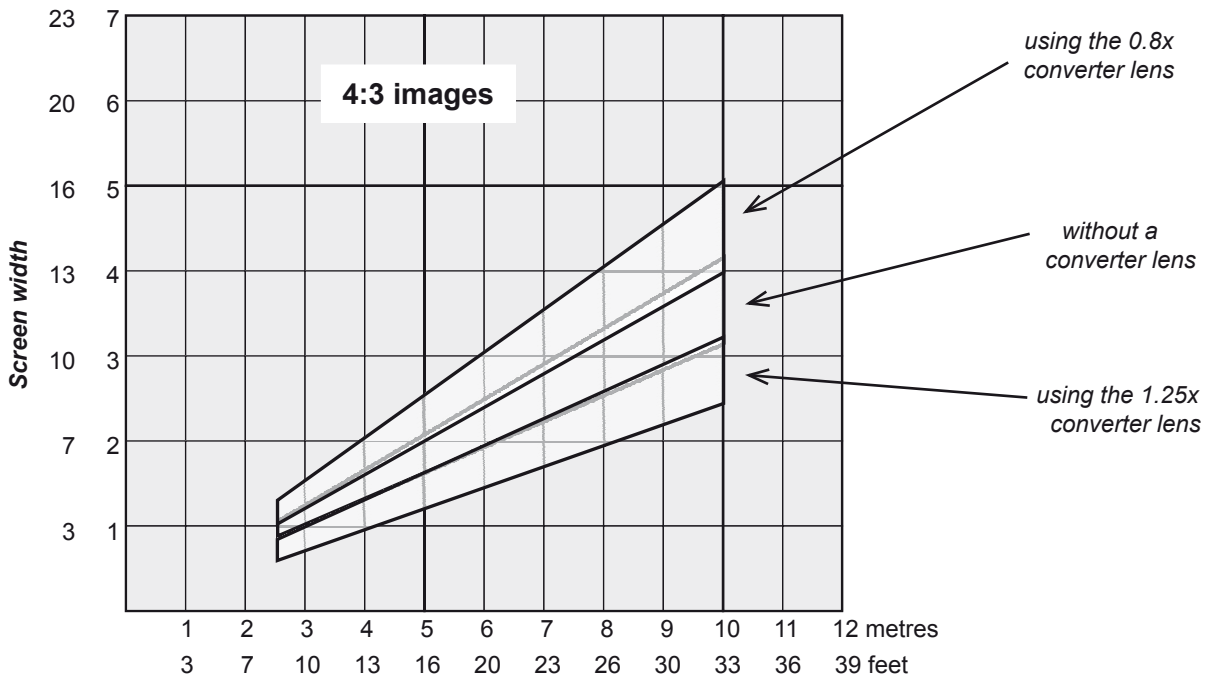
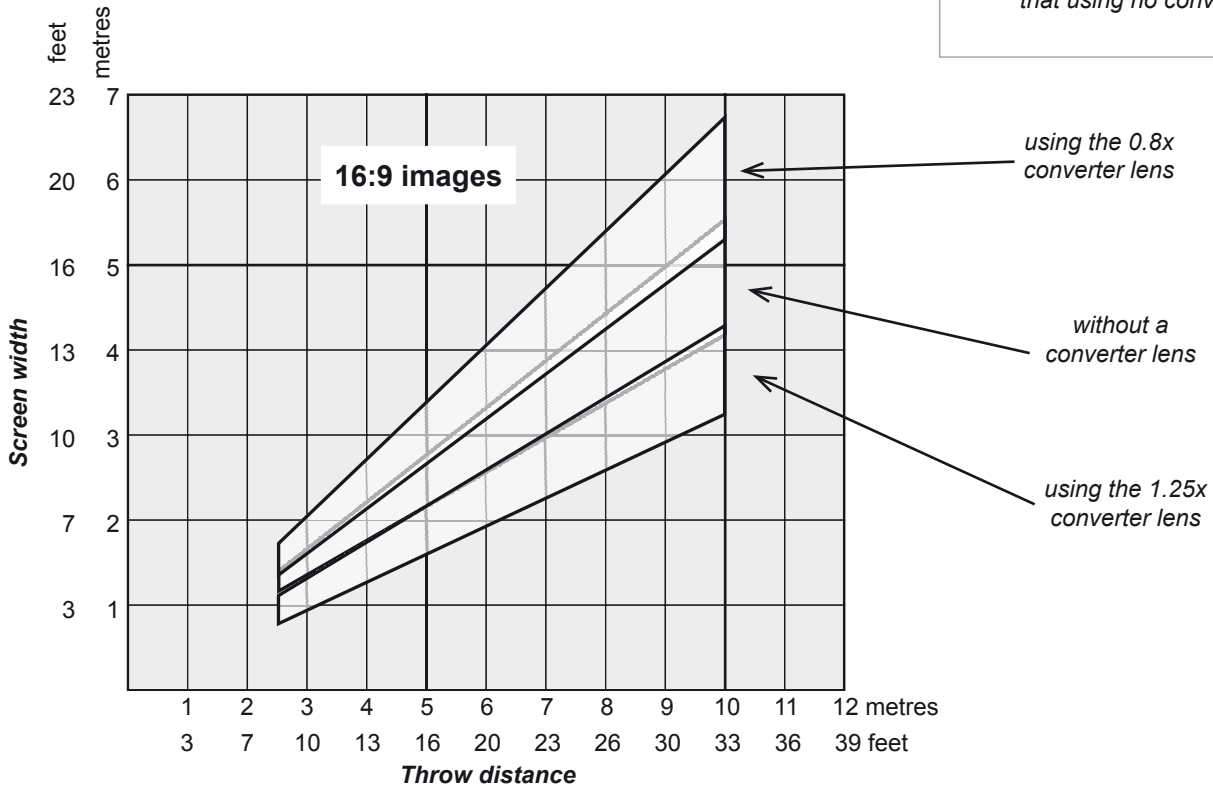

Shifting the image

Ideally, the projector should be positioned perpendicular to the screen.

The normal position for the projector is at the centre of the screen. However, you can set the projector above or below the centre, or to one side, and adjust the image using the **Lens shift** controls on the top of the projector to maintain a geometrically correct image.

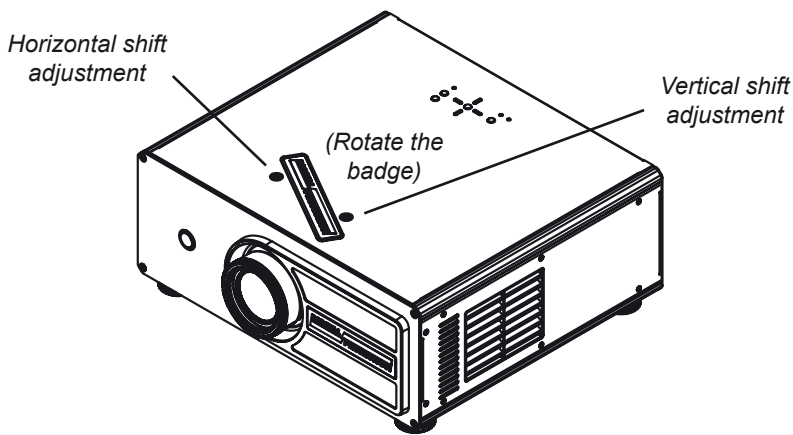
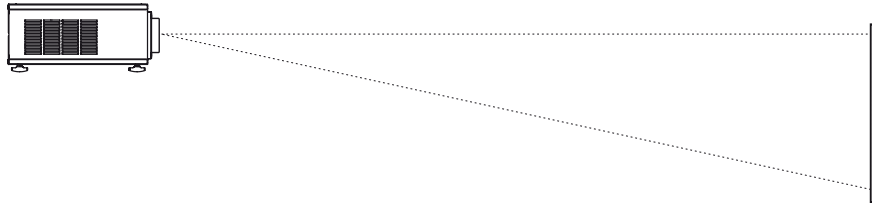

If the projector is fitted with the fixed 0.73:1 lens then there are no mechanical controls for lens shift.

The image can be shifted by up to:

- ± 0.6 of the height of a full screen image (known as 120% shift)
- ± 0.3 of the width of a full screen image (known as 60%)

and can be shifted by the full amount both horizontally and vertically together.

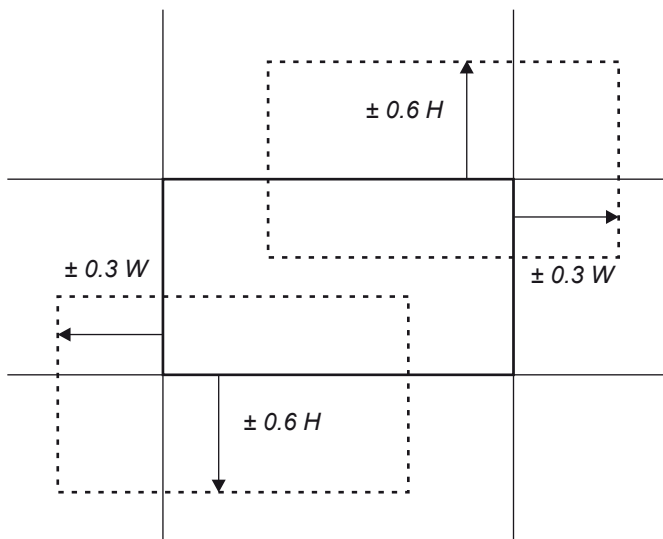

Mounting the projector

The four adjustable feet under the chassis allow the projector to be lowered onto a flat surface without any danger of hands being trapped between the bottom frame and the surface.

Ceiling mounting

The projector is designed to be used on a flat surface, but it can be suspended from a ceiling. Three M4 mounting holes with a 0.7mm pitch are provided under the projector to allow bolting to a ceiling mounting plate.

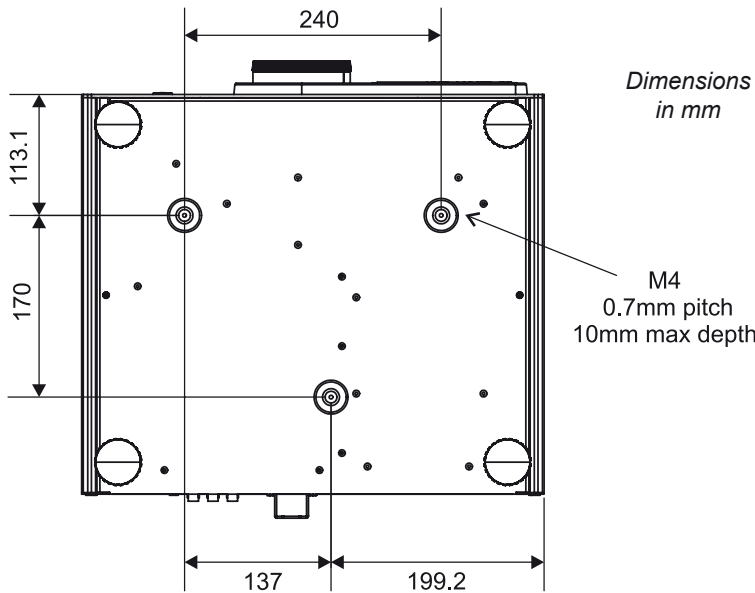





To use the projector upside down, set **Ceiling mode** to **On**, in the **System** menu, to invert the image.

Level adjustment

If the projector is to be operated from a flat surface such as a projector table, then adjustment of projector level should be made by turning the four feet under the chassis.

Ideally, the projector should be positioned perpendicular to the screen, and the lens shift controls used to align the image with the screen, to maintain a geometrically correct image.

Notes

-  **BEFORE INSTALLING THE PROJECTOR, READ ALL THE WARNINGS BELOW AND ALL THOSE IN IMPORTANT INFORMATION AT THE FRONT OF THIS MANUAL.**
-  **The projector weighs approximately 9 kg (20 lbs). Use safe handling techniques when lifting the projector.**
-  **Make sure that the surface, ceiling or rigging that is to support the projector is capable of supporting the weight of the projector.**
-  **Backup safety chains or wires should always be used with ceiling mount installations.**
-  **Do not tilt the projector more than $\pm 12^\circ$ in either direction when in use, as this may cause serious lamp failure, damage the lamp module and cause extra cost on replacement.**

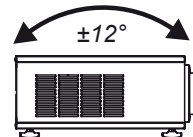
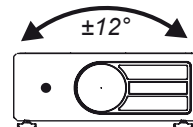

Rear projection

To use rear projection, set **Rear Projection** to **On**, in the **System** menu, to reverse the image.

In rear-screen applications where space behind the projector is limited, a mirror may be used to fold the optical path. The position of the projector and mirror must be accurately set. If you are considering this type of installation, contact your dealer for assistance

Stacking projectors

The projector is capable of supporting the weight of up to three other projectors safely. The stack should be positioned vertically and perpendicular to the screen, and the lens shift controls used to align the image with the screen, to maintain a geometrically correct image.

- Carefully lower each projector down onto the top of the others, making sure that they are vertically aligned with each other, and protected from becoming pushed over.
- Align the images from the projectors, using the **Lens shift** controls on the top of the projector.

Notes



For more detailed information about using the menus, see **section 4. Controlling the projector**.



Do not try to stack more than three projectors.



When stacking projectors, the stack MUST be vertical, to ensure that the stresses are distributed to all four chassis corners.



Make sure that the surface, ceiling or rigging that is to support the projector is capable of supporting the combined weight of all the projectors.



Do not place heavy objects on top of the projector chassis. Only the chassis corners are capable of withstanding the weight of another projector.



Backup safety chains or wires should always be used with ceiling mount installations.



If the projector is fitted with the fixed 0.73:1 lens then there are no mechanical controls for lens shift.

Connecting the projector

Signal Inputs

The following inputs are available:

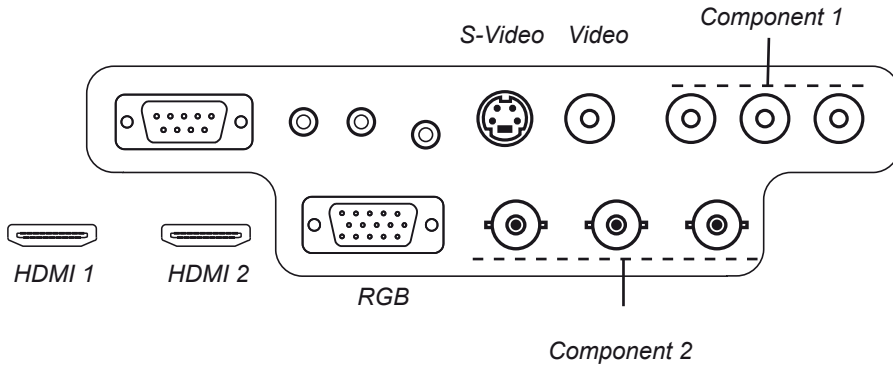

- HDMI 1 & 2** HDCP-compliant digital video inputs from HDMI or DVI sources.
- RGB** 15 pin D-type VGA style input from personal computer
- Component 1** RCA phono connectors for RGBS, (using Video input for sync) or YPbPr
- Component 2** BNC connectors for YPbPr
- Video** RCA phono connector for composite video or used as sync input for Component 1
- S-Video** standard 4 pin S-Video connector

Notes

For more information on selecting an input source, see **section 4. Overview, Using the control keys, and Using the menus.**

For more information about pin connections and control codes see **section 6. Appendix.**

Input connection examples

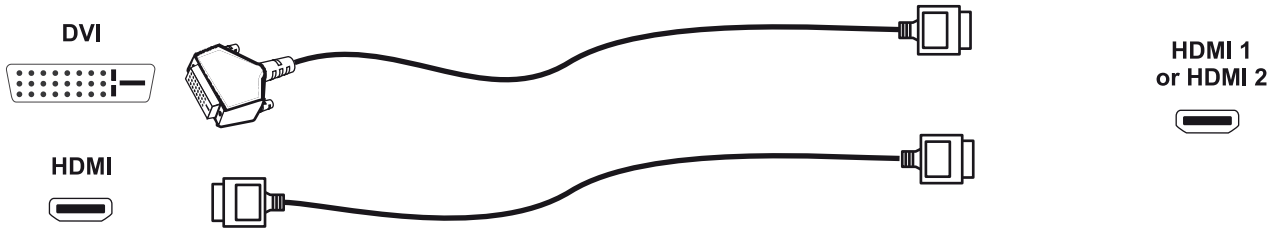

Notes
 For more information about pin connections and control codes see section 6. Appendix.

Input connection examples, continued

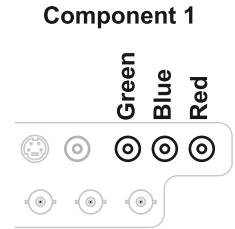
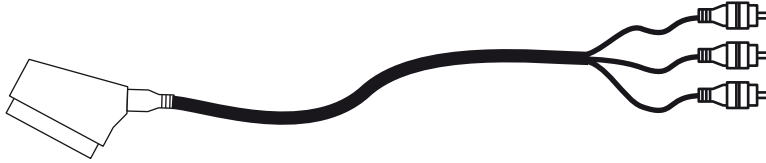

RGsB

Red
Green
Blue

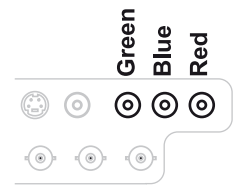

Y
Pb / Cb
Pr / Cr

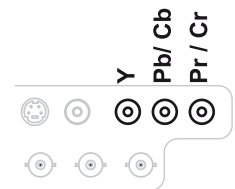

Y
Pb / Cb
Pr / Cr

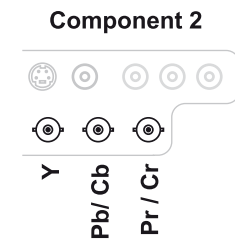

Composite Video

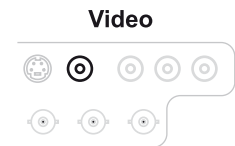

S-Video



Control connections

The following connections are available:

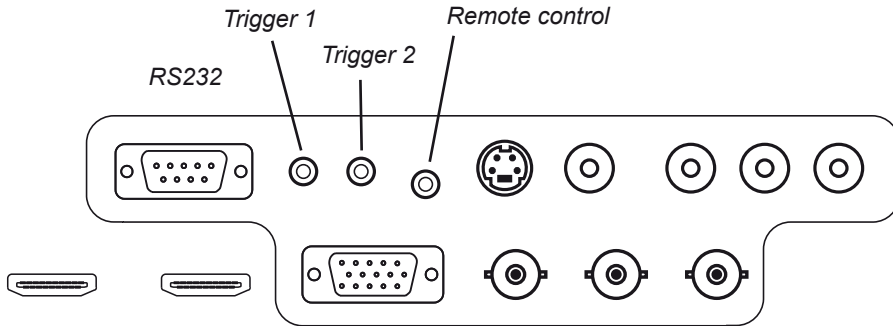

Notes

 For more information about pin connections and control codes see **section 6. Appendix.**

Remote control

If infrared signals from the remote control cannot reach the projector due to excessive distance or obstructions such as walls or cabinet doors, you can connect an external IR repeater to the Remote control input, and position its IR sensor within range of the operator.

RS232 connection

All of the projector's features can be controlled via a serial connection, using the text strings described in **Remote communications protocol**, in **section 6. Appendix.**

The RS232 connection can also be used to download the firmware updates, issued from time to time by Digital Projection.

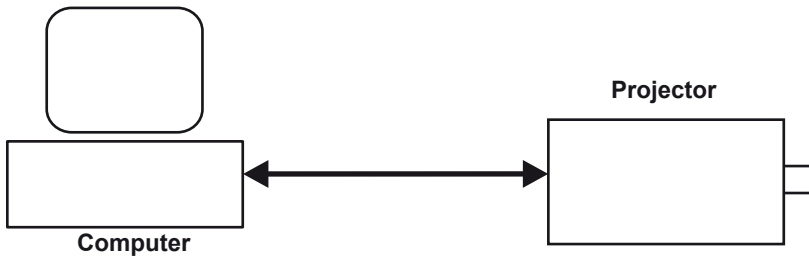

Trigger 1 & 2



- Trigger 1** Screen trigger output: can be connected to an electrically operated screen, automatically deploying the screen when the projector starts up, and retracting the screen when the projector shuts down.
- Trigger 2** Aspect Ratio trigger output: can be used to control screen shuttering for different aspect ratios

Power connection

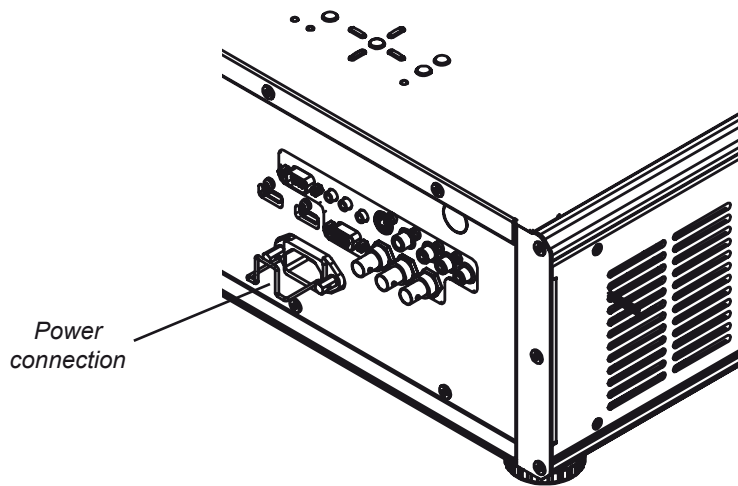
Lift the cable lock up, push the mains connector in firmly, then push the lock down to secure the cable.



Notes

-  Use only the power cable provided.
-  Ensure that the power outlet includes a Ground connection, as this equipment **MUST** be earthed.
-  Handle the power cable carefully and avoid sharp bends. Do not use a damaged power cable.

3. Getting Started

Contents

Positioning the screen and projector	3.2
Switching the projector on	3.2
Inserting batteries into the remote control.....	3.2
Selecting an input signal or test pattern.....	3.3
Input.....	3.3
Test pattern	3.3
Adjusting the lens.....	3.3
Zoom.....	3.3
Focus	3.3
Shift.....	3.3
Adjusting the projected image	3.4
Aspect ratio.....	3.4
Image quality settings.....	3.4
Switching the projector off.....	3.4

Positioning the screen and projector



- Install the screen, ensuring that it is in the best position for viewing by your audience.
- Mount the projector, ensuring that it is at a suitable distance from the screen for the image to fill the screen, and that it is perpendicular to the screen.

Switching the projector on

- Connect the power cable between the mains supply and the projector.

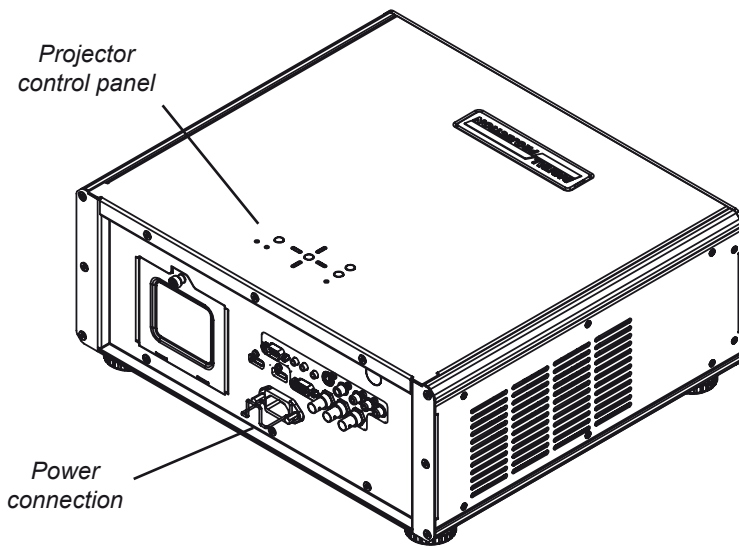
Wait until the self-test has completed and the standby indicator on the projector control panel shows amber. The lamp will be off and the projector will be in STANDBY mode.



- Press POWER ON  on the remote control or POWER  on the projector control panel to switch the projector ON. The power indicator on the control panel will flash blue for approximately 30 seconds, whilst the lamp comes up to full brightness. When the projector is ready for use, the power indicator will show a steady blue.

Inserting batteries into the remote control

- Open the battery compartment and insert two AA size batteries, making sure they are inserted the correct way round, as shown below.

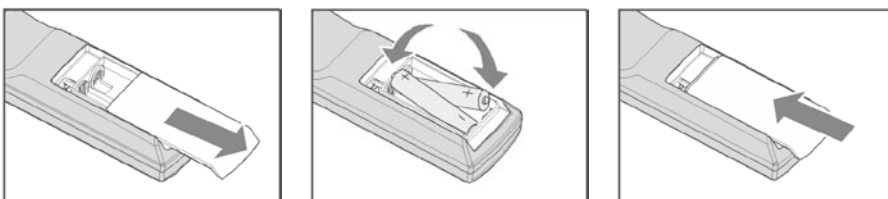

Notes

 For more information about positioning the screen and projector, see **Positioning the screen and projector**, in section 2. of the User Manual: Installation.

 For more detailed information about:

- using the control keys on the remote control or the projector control panel,
- using the menus,

see section 4. of the User Manual: Controlling the projector.

 If the red **ISSUE** indicator is illuminated continuously or flashing, see **Error Codes** in section 6 of the User Manual: Appendix, for more information

 Do not mix an old battery with a new one or different types of batteries.

 If you will not use the remote control for a long time, remove the batteries to avoid damage from battery leakage.

Selecting an input signal or test pattern

Input

- Connect an video source to the projector. The signal should be automatically detected by the projector, and should be displayed within a two or three seconds.
- If more than one signal is connected to the projector, then select which signal is to be displayed, using the **1** to **5** buttons on the remote control, or by pressing the SOURCE button on the projector control panel until the correct signal is displayed.

Test pattern

If you have no video source connected to the projector, then you can display a test pattern as follows:

- Press **TEST** on the remote control, until the desired test pattern is displayed.

Adjusting the lens

Zoom

- Turn the smooth ring on the lens, closest to the case, to adjust the zoom so that the image fills the screen.

Focus

- Turn the knurled ring at the outer end of the lens, to adjust the focus until the image is sharp.

Shift

- Rotate the Digital Projection badge on top of the projector to reveal the shift adjustment access holes. Use the 5mm allen wrench to adjust the horizontal and vertical position of the image.

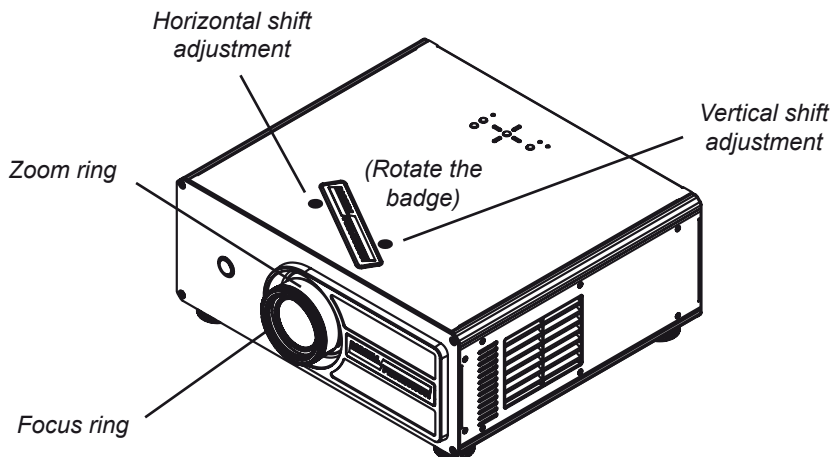

Notes

 For more information about connecting input signals, see **Signal Inputs**, in section 2. of the User Manual: Installation.

 For more detailed information about input connections, see **Input signals** in section 6. of the User Manual: Controlling the projector.

 For more information about lens shift, see **Shifting the image** in section 2. of the User Manual: Installation.

Adjusting the projected image

Aspect ratio

- Press  on the remote control until the image is displayed in the correct aspect ratio.

Image quality settings

- Press any of the following keys on the remote control, followed by ◀ and ▶, to adjust these image quality settings:

Brightness 

Contrast 

Sharpness 

Notes



For more detailed information about:

- using all the control keys on the remote control or the projector control panel,

- using the menus,

see **section 4. of the User Manual: Controlling the projector.**





For the picture setting adjustments shown here:

- after 5 seconds, if no adjustment has been made, the indicator will go out and the adjustment key must be pressed again.

- to end the adjustment before 5 seconds has elapsed, press a different adjustment key, or press the key again.

Switching the projector off

- Press POWER OFF  on the remote control or POWER  on the projector control panel, then press the button a second time to confirm your intention to switch off.

The lamp will switch off, and the power indicator on the control panel will flash blue for approximately 30 seconds until the lamp has cooled down.

- Wait until the power indicator has switched off and the standby indicator on the projector control panel shows amber. The projector will now be in STANDBY mode.
- Disconnect the power cable from the projector.



Always allow the lamp to cool for 5 minutes before:

- moving the projector
- changing the lamp

4. Controlling the projector

Contents

Overview	4.3
Controlling the projector.....	4.3
The control panel	4.4
LED status indicators	4.4
The remote control	4.5
Layout	4.5
Timeout.....	4.5
Using the control keys	4.6
Power	4.6
Source.....	4.6
Aspect ratio	4.6
User memory.....	4.6
Image quality settings.....	4.7
<i>Example - Brightness screen control:</i>	4.7
Test pattern	4.7
Using the menus	4.8
Navigating menus and submenus.....	4.8
Main menu	4.9
Aspect Ratio.....	4.9
Presets	4.10
<i>Recall Presets</i>	4.10
<i>Save Presets</i>	4.10
Brightness.....	4.11
Contrast.....	4.11
Saturation	4.11
Hue	4.11
Sharpness.....	4.12
Noise Reduction	4.12
Overscan	4.12
Input Select.....	4.13
Resync	4.13
Advanced menu	4.14
Colour Space	4.14
Video Standard.....	4.15
Gamma.....	4.15
Colour Temperature	4.15
Colour Gamut.....	4.16
Brilliant Color®	4.16

continued

Adaptive Contrast	4.16
RGB Adjust	4.17
<i>Offsets</i>	4.17
<i>Gains</i>	4.17
Fine Sync.....	4.18
System menu	4.19
Language.....	4.19
Source Enable.....	4.20
Menu Position.....	4.21
Blank Screen.....	4.21
Auto Power On	4.21
Auto Power Off	4.21
Rear Projection.....	4.22
Ceiling Mode	4.22
Logo Display	4.22
Control menu	4.23
Trigger 1 & 2	4.23
Auto Source	4.24
Keys 1 to 5.....	4.24
Service menu	4.25
Factory Reset.....	4.25
Blue Only	4.26
Test Patterns	4.26
Altitude	4.26

continued

Overview

Controlling the projector

The projector can be controlled from:

- the remote control
- the projector control panel
- the RS232 input

For more information about controlling the projector using the RS232 input, see **Remote communications protocol** in **section 6. Appendix**.

For information about how to connect the projector, see **Connecting the projector** in **section 2. Installation**, and **Connections** in **section 6. Appendix**.

- Many features are controlled from the menus using the menu navigation keys on the remote control or the projector control panel.

For more information about using the menus, see later in this section, **Using the menus**.

- Some of the menu features, for example brightness, contrast and sharpness, can be accessed directly using the control keys at the bottom of the remote control.

Notes

The control panel

The projector control panel is designed to be read from the front or rear of the projector, for ease of use.

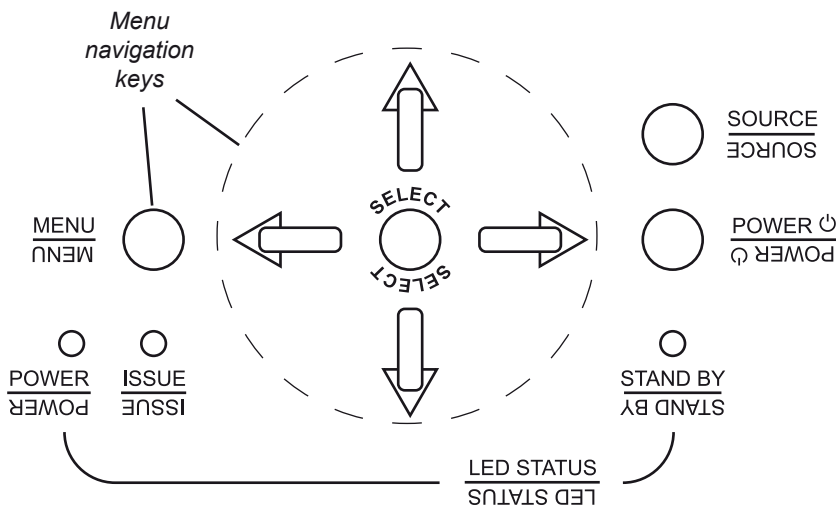

The menu navigation keys are similar to those on the remote control, and are described in detail in **Using the menus**, later in this section.

POWER Press this once to switch the projector ON or twice to switch it to STANDBY mode.

SOURCE Press this repeatedly to cycle through the input sources, in the following order:

HDMI 1, HDMI 2, RGB, Composite 1, Composite 2, Video, S-Video, HDMI 1...

If you select a source that IS connected and active, the projector will automatically adjust to the parameters of the signal, and display it.

If you select a source that is NOT connected or active, the projector will continue searching through the input sources until it finds a valid signal.

LED status indicators

The indicators on the control panel are as follows:

POWER *off* = NO POWER *steady blue* = normal RUNNING mode

flashing blue = LAMP WARM-UP or COOL-DOWN mode

ISSUE *off* = NO ERROR *flashing or steady red* = ERROR

STANDBY *amber* = STANDBY mode

Notes

Many features are controlled from the menus using the **menu navigation keys** on the remote control or the projector control panel.

For more information about using the menus, see later in this section, **Using the menus**.

Always allow the lamp to cool for 5 minutes before:

- moving the projector
- changing the lamp

If the red **ISSUE** indicator is illuminated continuously or flashing, see **Error Codes** in section 6. Appendix, for more information

The remote control

Layout

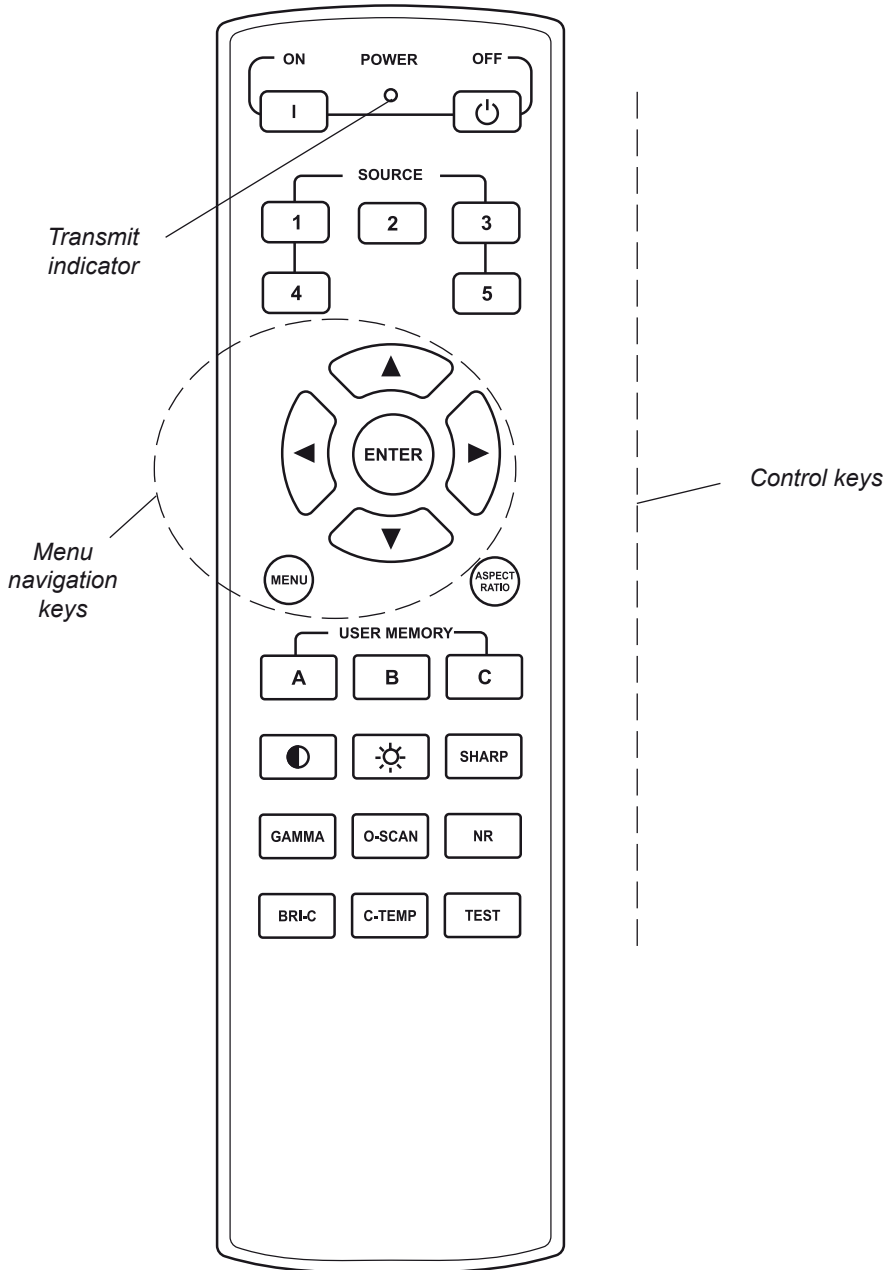

Notes

Many features are controlled from the menus using the **menu navigation keys** on the remote control or the projector control panel.

For more information about using the menus, see later in this section, **Using the menus**.

Some of the menu features, for example brightness, contrast and sharpness, can be accessed directly using the **control keys** at the bottom of the remote control.

For more information about using the control keys, see later in this section, **Using the control keys**.

In most situations, you can simply point the remote control at the screen which will reflect the IR signal from the remote back toward the receiver on the projector.

In some cases, however, ambient conditions may prevent this. In this case, point the remote control directly at the projector.

Timeout

There is a 5 second timeout for the **control** keys at the bottom of the remote control:

- after 5 seconds, if no adjustment has been made, the indicator will go out and the adjustment key must be pressed again.
- to end the adjustment before 5 seconds has elapsed, press a different adjustment key, or press the key again.

There is a 30 second timeout for the **menu navigation** keys.

Remote reception angle

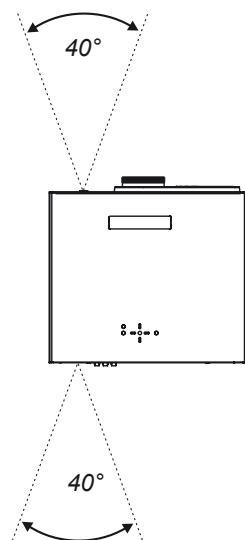

Using the control keys

Power

- Press POWER ON  on the remote control to switch the projector ON.



The power indicator on the control panel will flash blue for approximately 30 seconds, whilst the lamp comes up to full brightness. When the projector is ready for use, the power indicator will show a steady blue.

- Press POWER OFF  on the remote control to switch the projector to STANDBY mode.

Press the button a second time to confirm your intention to switch to STANDBY mode.

The lamp will switch off, and the power indicator on the control panel will flash blue for approximately 30 seconds until the lamp has cooled down. Wait until the power indicator has switched off and the standby indicator on the projector control panel shows amber. The projector will now be in STANDBY mode.

Source

- To switch to one of the five sources programmed into the SOURCE buttons, then select using the  to  keys.

If you select a source that IS connected and active, the projector will automatically adjust to the parameters of the signal, and display it.

If you select a source that is NOT connected or active, the projector will continue searching through the input sources until it finds a valid signal, in this order.



HDMI 1, HDMI 2, RGB, Composite 1, Composite 2, Video, S-Video, HDMI 1...

Aspect ratio

- Press  repeatedly to cycle through the **Aspect ratio** settings, in the following order:

16:9, Theaterscope, 4:3, 4:3 Narrow, Native, 16:9...

User memory

- To switch to one of the three sets of image settings programmed into the USER MEMORY buttons, then select using the   or  keys.

Notes

 For more information about the sources programmed into the SOURCE keys, see **Control menu** later in this section, **Using the menus**.

 For more information about the Aspect ratio settings, see **Screen requirements** in section 2. **Installation**.

 For more information about the settings programmed into the USER MEMORY keys, see **Control menu** later in this section.

Note: User memory D is available only through the Control menu.

Image quality settings

- Press any of the following keys on the remote control, followed by ◀ and ▶, to adjust these image quality settings:

Brightness 

Contrast 

Sharpness 

Gamma 

Overscan 

Noise reduction 

Brilliant-color 

Colour temperature 

Example - Brightness screen control:





Test pattern

- Press the  key repeatedly to cycle through the **Test patterns**, in the following order:

White, Black, Red, Green, Blue, Cyan, Magenta, Yellow, Chequerboard, Greyscale, Alignment grid, White...

Notes

 For more information about all these image quality settings, and more, see **Main menu** and **Advanced menu** later in this section, **Using the menus**.

 Some of the settings will not be available for some of the input sources.

Using the menus

Navigating menus and submenus

The menus are organised into five pages. When the menus are in use, the **menu page headings** are always visible at the top of the menu panel.

Most **menu** items can be adjusted directly, but some items lead to a **submenu**.

The menus will always open at the same page that was last viewed. The example below shows the first menu page displayed following power on, which is always the **Main menu**.

MAIN	ADVANCED	SYSTEM	CONTROL	SERVICE
Aspect Ratio	16:9	Theaterscope	4:3	4:3 Narrow Native
Presets		Enter		
Brightness		100		
Contrast		100		
Saturation		100		
Hue		100		
Sharpness		100		
Noise Reduction		100		
Overscan	Off	Crop	Zoom	
Input Select		Enter		
Resync		Enter		
Menu = Exit Menu Select ◀▶ Scroll ▲▼				

- Use the navigation keys on the remote control or the projector control panel to navigate through the menus:

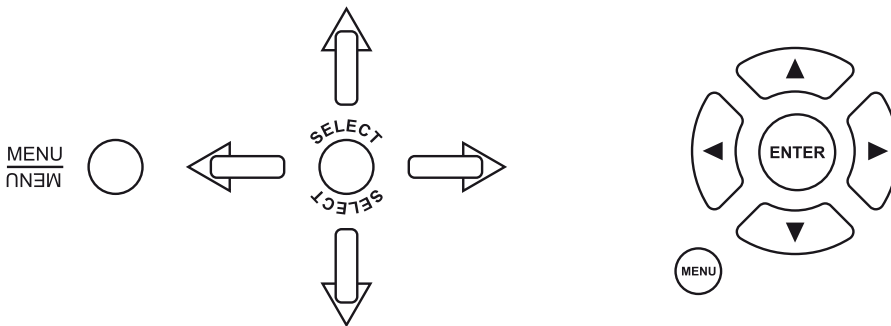

- To display the menus, press MENU (MENU) on the remote control or the projector control panel.
- To select a different menu page, use the ◀ and ▶ keys.
- To select a menu item, use the ▲ and ▼ keys.
- To close a menu, press MENU (MENU) again.

Notes





- Some menu controls can be accessed directly using the **control keys** (see earlier in this section).
- There is a 30 second timeout for the menu navigation keys. If a menu times out, simply press the **Menu** key again.

The **SELECT** key on the projector control panel has exactly the same function as the **ENTER** key on the remote control.

To exit from the menus completely, you may need to press (MENU) up to three times.

Main menu

- To display the menus, press MENU  on the remote control or the projector control panel.
- Use the  and  keys to select the **Main menu** page,

MAIN	ADVANCED	SYSTEM	CONTROL	SERVICE
Aspect Ratio	16:9	Theaterscope	4:3	4:3 Narrow Native
Presets		Enter		
Brightness		100		
Contrast		100		
Saturation		100		
Hue		100		
Sharpness		100		
Noise Reduction		100		
Overscan	Off	Crop	Zoom	
Input Select		Enter		
Resync		Enter		
Menu = Exit Menu Select   Scroll  				





- To select a menu item, use the  and  keys until the item is highlighted.



Aspect Ratio

- Use the  and  keys to select from:

- 16:9** the image is scaled to fill the DMD (and thus, a 16:9 screen).
- Theaterscope** the image is scaled such that a 2.35:1 image will be displayed at the correct aspect ratio when the projector is fitted with an anamorphic lens. Thus an image with an aspect ratio of 2.35:1 can be displayed using the full 16:9 resolution of the DMD.
- 4:3** the image is scaled to fit a 4:3 screen, using the full height of the DMD.
- 4:3 Narrow** to be used for 4:3 images in combination with an anamorphic lens. The image is scaled to fit the DMD vertically, but squeezed horizontally such that the lens will stretch it to the correct ratio.
- Native** the image is displayed with no scaling, at its original resolution, in the centre of the screen.

Notes

 To select a different menu, press MENU  once or twice, so that no items are highlighted, then use the  and  keys to select a different page.

 To exit from the menus completely, you may need to press  up to three times.

 Image changes made using the menus will take effect immediately.

 Some menu items may be greyed out - unavailable due to the effect of settings made in other menus, or due to the type of input signal.

 For more information about the **Aspect ratio** settings, see **Screen requirements** in section 2. **Installation**.

Main menu continued

Presets

- Press ENTER or SELECT.

The **Presets** submenu will appear:

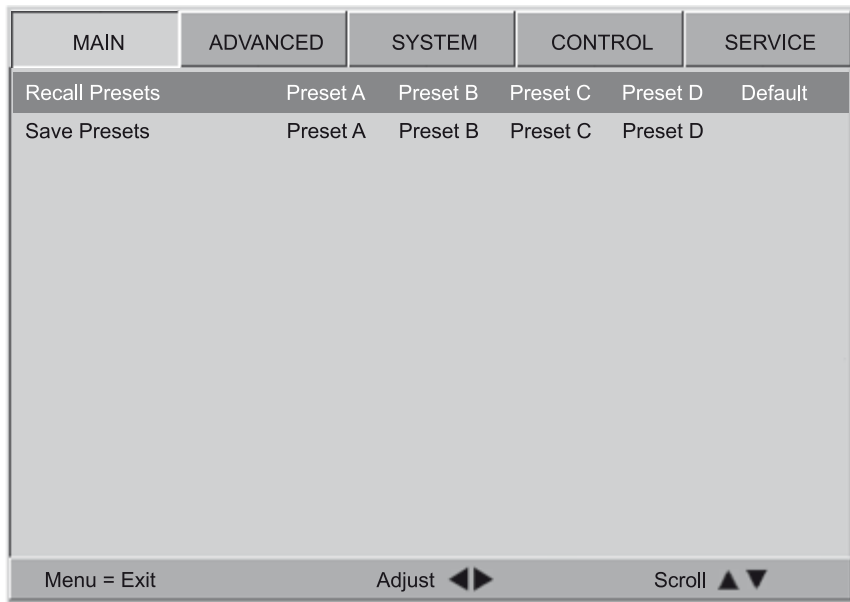

- Use the ▲ and ▼ keys to select from:

Recall Presets

Save Presets

Recall Presets

Recall a set of image settings that have previously been saved to Presets A, B, C or D.

- Use the ◀ or ▶ keys to select which Preset is to be recalled.
- Select **Default**, to recall the factory default settings.

Save Presets

Save the the image settings for all seven inputs to the selected **Preset**.



- Use the ◀ or ▶ keys to select which Preset the settings will be saved to.



The following settings will be saved:

Brightness	Contrast	Saturation
Hue	Sharpness	Noise Reduction
Color Space	Video Standard	Gamma
Colour Temperature	Color Gamut	Brilliant Color
Adaptive Contrast	RGB Offsets	RGB Gains

- To return to the **Main menu**, press  once.

Notes

 To select a different menu, press **MENU**  once or twice, so that no items are highlighted, then use the ◀ and ▶ keys to select a different page.

 To exit from the menus completely, you may need to press **MENU**  up to three times.

 Image changes made using the menus will take effect immediately.

 The **Presets** can also be recalled using the **USER MEMORY** keys on the remote control. See **Using the control keys** earlier in this section.

*Note: **Preset D** is available only through the **Control menu**, not through the remote control.*

 When **Save Presets** is selected, the image settings for **ALL** seven inputs are saved.

Main menu continued

Brightness

- Press ◀ or ▶ once.



After the first press, the **Brightness** adjustment bar will appear:

- Use the ◀ and ▶ keys to adjust the **Brightness** from 0 to 200:
- To return to the **Main menu**, press  once.

Contrast

- Press ◀ or ▶ once.

After the first press, the **Contrast** adjustment bar will appear.

- Use the ◀ and ▶ keys to adjust the **Contrast** from 0 to 200:
- To return to the **Main menu**, press  once.

Saturation

Saturation is the amount of colour in the image. Decrease this setting if colors are too bright; increase it if colors appear muted or washed out.

- Press ◀ or ▶ once.

After the first press, the **Saturation** adjustment bar will appear.

- Use the ◀ and ▶ keys to adjust the **Saturation** from 0 to 200:
- To return to the **Main menu**, press  once.

Hue



Hue is the ratio of red to green in the image. Decrease this setting to shift the hue toward red; increase it to shift the hue toward green.

- Press ◀ or ▶ once.

After the first press, the **Hue** adjustment bar will appear.

- Use the ◀ and ▶ keys to adjust the **Hue** from 0 to 200:
- To return to the **Main menu**, press  once.

Notes

 To exit from the menus completely, you may need to press  up to three times.

 Image changes made using the menus will take effect immediately.

 Image changes made using the menus will take effect immediately.

 Some menu items may be greyed out - unavailable due to the effect of settings made in other menus, or due to the type of input signal.

 Image quality settings are often interactive - a change in one setting may require a change to be made in another setting.

 Setting Adaptive Contrast to On in the Advanced menu will affect any image quality settings made in other menus.

Main menu continued**Sharpness**

- Press ◀ or ▶ once.
After the first press, the **Sharpness** adjustment bar will appear.
- Use the ◀ and ▶ keys to adjust the **Sharpness** from 0 to 200:
- To return to the **Main menu**, press  once.

Noise Reduction

- Press ◀ or ▶ once.
After the first press, the **Noise reduction** adjustment bar will appear.
- Use the ◀ and ▶ keys to adjust the **Noise reduction** from 0 to 200:
- To return to the **Main menu**, press  once.

Overscan

Some television programs are produced based on the assumption that older television sets may not display the outer edges of the broadcast picture area. Consequently the edges of the image may be noisy or badly defined. Overscan is used to compensate for this, by hiding the outer edges of the image.



- Use the ◀ or ▶ keys to select from:

Off

Crop blanks a 3% border from the left and right edges of the image

Zoom increases the horizontal and vertical resolution of the displayed image by 6%, so that the all four edges fall outside the screen area

Notes

 To exit from the menus completely, you may need to press  up to three times.

 Image changes made using the menus will take effect immediately.

 Some menu items may be greyed out - unavailable due to the effect of settings made in other menus, or due to the type of input signal.

 When the **Aspect Ratio** is set to **Native**, **Overscan** can only be set to **Off** or **Crop**

Main menu continued

Input Select

- Press ENTER or SELECT.

The **Input select** submenu will appear:

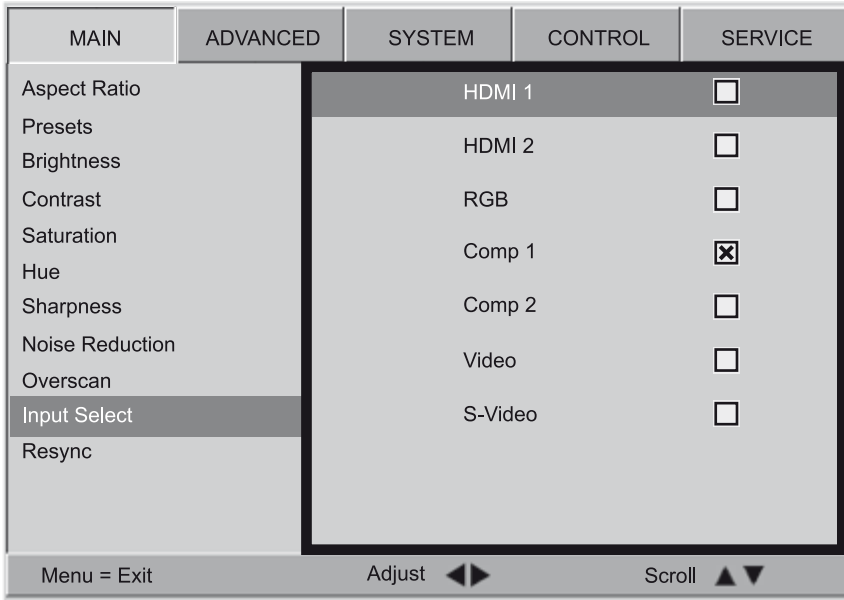

- Use the ▲ and ▼ keys to select from:

HDMI 1

HDMI 2

RGB

Component 1

Component 2

Video

S-Video

- Press ENTER or SELECT, to select a different input source.

- To return to the **Main menu**, press  once.



Resync



If the image has become unstable or degraded, it may be possible to improve the display:

- Press ENTER or SELECT.

The projector will attempt to re-synchronise to the current input source.

Notes

 To select a different menu, press **MENU**  once or twice, so that no items are highlighted, then use the ◀ and ▶ keys to select a different page.

 To exit from the menus completely, you may need to press **MENU**  up to three times.

 Image changes made using the menus will take effect immediately.

 Some menu items may be greyed out - unavailable due to the effect of settings made in other menus, or due to the type of input signal.

 If you select a source that IS connected and active, the projector will automatically adjust to the parameters of the signal, and display it.





If you select a source that is NOT connected or active, the projector will continue searching through the input sources until it finds a valid signal, in this order.

HDMI 1, HDMI 2, RGB, Composite 1, Composite 2, Video, S-Video, HDMI 1...

Advanced menu

- To display the menus, press MENU  on the remote control or the projector control panel.
- Use the  and  keys to select the **Advanced menu** page,

MAIN	ADVANCED	SYSTEM	CONTROL	SERVICE	
Color Space	Auto	YPbPr	YCbCr	RGB-PC	RGB-Video
Video Standard	Auto	NTSC	PAL	SECAM	
Gamma	CRT	Film	Video	Punch	Graphics
Color Temperature	5500K	6500K	7500K	9300K	Native
Color Gamut	Auto	REC709	SMPTE-C	EBU	Native
Brilliant Color	On		Off		
Adaptive Contrast	On		Off		
RGB Adjust			Enter		
Fine Sync			Enter		

Menu = Exit Menu Select   Scroll  

- To select a menu item, use the  and  keys until the item is highlighted.





Colour Space



In most cases, the **Auto** setting will determine the correct color space to use. If it does not, you can select the appropriate setting manually.

- Use the  and  keys to select from:

- Auto**
- YPbPr**
- YCbCr**
- RGB-PC**
- RGB Video**

Notes

 To select a different menu, press MENU  once or twice, so that no items are highlighted, then use the  and  keys to select a different page.

 To exit from the menus completely, you may need to press  up to three times.

 Image changes made using the menus will take effect immediately.

 Some menu items may be greyed out - unavailable due to the effect of settings made in other menus, or due to the type of input signal.

 To determine what is the correct colour space to use, consult the user manual for the video source.

Advanced menu continued

Video Standard

In most cases, the **Auto** setting will determine the correct video standard to use. If it does not, you can select the appropriate setting manually.

- Use the ◀ and ▶ keys to select from:

Auto

NTSC used mainly in the United States and Japan

PAL used in Europe, Australia and many other parts of the world, typically with a 50Hz frame rate

SECAM used mainly in France and Russia

Gamma

Video recordings are often supplied with a gamma adjustment applied. The projector’s gamma setting can be used to correct for this. If you are unsure, then choose a setting that gives a decent level of contrast, whilst maintaining good detail in the darkest and lightest areas of the image.

- Use the ◀ and ▶ keys to select from:

CRT gamma of 2.5

Film gamma of 2.2

Video similar to Film but improves the dark areas of the image - especially suitable for images from video cameras

Punch enhanced brightness and increased colour saturation for high ambient light environments

Graphics enhanced highlights and contrast, especially suitable for computer presentations

Colour Temperature

In general, a higher colour temperature gives a cooler feeling to the image, and a lower temperature gives a warmer feeling.

- Use the ◀ and ▶ keys to select from:

5500K



6500K

7500K

6300K

Native

Notes

 To exit from the menus completely, you may need to press  up to three times.

 Image changes made using the menus will take effect immediately.

 Some menu items may be greyed out - unavailable due to the effect of settings made in other menus, or due to the type of input signal.

 Image quality settings are often interactive - a change in one setting may require a change to be made in another setting.

 Setting Adaptive Contrast to On will affect any image quality settings made in other menus.

Advanced menu continued**Colour Gamut**

In most cases, the **Auto** setting will determine the correct colour gamut to use. If it does not, you can select the appropriate setting manually.

Each setting defines the precise hue of each primary (red, green and blue) and secondary (yellow, cyan and magenta) color component used to generate the image.

- Use the ◀ and ▶ keys to select from:

Auto

SMPTE-C for NTSC, 480i and 480p sources

EBU for PAL, SECAM, 576i and 576p sources

REC709 for most other sources

Native uncorrected

Brilliant Color®

Brilliant Color® allows for increased projector brightness and improved color saturation by enabling the yellow segments on the colour wheel.

- Use the ◀ and ▶ keys to select from:

On (recommended)

Off

Adaptive Contrast

Adaptive Contrast expands the light and dark portions of the contrast curve of the image, depending on the mean luminance of the image.

- Use the ◀ and ▶ keys to select from:

On

Off

Notes

To exit from the menus completely, you may need to press  up to three times.



Image changes made using the menus will take effect immediately.



Some menu items may be greyed out - unavailable due to the effect of settings made in other menus, or due to the type of input signal.



In most cases, **Brilliant Color** should be left **On** – switching it **Off** will result in reduced brilliance and contrast.



Setting **Adaptive Contrast** to **On** will affect any image quality settings made in other menus.

Advanced menu continued

RGB Adjust

- Press ENTER or SELECT.

The RGB Adjust submenu will appear:

MAIN	ADVANCED	SYSTEM	CONTROL	SERVICE
Red Offset			100	
Blue Offset			100	
Green Offset			100	
Red Gain			100	
Blue Gain			100	
Green Gain			100	

Menu = Exit Adjust ◀▶ Scroll ▲▼

Use the Gain controls to correct color imbalances in the bright areas of the image. Use the Offset controls in the RGB Adjust sub-menu to correct color imbalances in the dark areas of the image.

- Use the ▲ and ▼ keys to select from:

- Red Offset
- Blue Offset
- Green Offset
- Red Gain
- Blue Gain
- Green Gain



Offsets



- Use the ◀ and ▶ keys to adjust the Offset from 0 to 200.

Gains

- Use the ◀ and ▶ keys to adjust the Gain from 0 to 200.
- To return to the Advanced menu, press MENU once.

Notes

 To select a different menu, press MENU  once or twice, so that no items are highlighted, then use the ◀ and ▶ keys to select a different page.

 To exit from the menus completely, you may need to press  up to three times.

 Image changes made using the menus will take effect immediately.

 Some menu items may be greyed out - unavailable due to the effect of settings made in other menus, or due to the type of input signal.

 A good way to carry out this adjustment is to use the chequerboard test pattern.

 RGB settings are interactive - a change in one setting may require a change to be made in the other.

Advanced menu continued**Fine Sync**

- Press ENTER or SELECT.



The **Fine Sync** submenu will appear:



MAIN	ADVANCED	SYSTEM	CONTROL	SERVICE
V Position			100	
H Position			100	
Phase			100	
Tracking			100	
Sync Level			100	

Menu = Exit Adjust ◀▶ Scroll ▲▼

- Use the ▲ and ▼ keys to select from:
 - V Position** fine tunes the vertical position of the image
 - H Position** fine tunes the horizontal position of the image
 - Tracking** adjusts the frequency of the pixel sampling clock, so that all pixels generated by the video source are sampled. Steady flickering or several soft vertical stripes or bands across the entire image indicate poor pixel tracking.
 - Phase** adjusts the phase of the pixel sampling clock relative to the incoming signal. Adjust the phase when an RGB or Component image still shows shimmer or noise after the **tracking** has been optimized.
 - Sync Level** adjusts the voltage level of the projector's sync signal detection circuitry. Sync Level adjustment is occasionally necessary when a signal source signal drops "below black" (for example, during scenes with explosions or when subtitles are present) and causes the projector to temporarily lose sync.
- Use the ◀ and ▶ keys to adjust the setting from 0 to 200.
- To return to the **Advanced menu**, press  once.

Notes

 To select a different menu, press **MENU**  once or twice, so that no items are highlighted, then use the ◀ and ▶ keys to select a different page.

 To exit from the menus completely, you may need to press **MENU**  up to three times.

 Image changes made using the menus will take effect immediately.

 Some menu items may be greyed out - unavailable due to the effect of settings made in other menus, or due to the type of input signal.

 A good way to carry out tracking and phase adjustments is to use the grey scale test pattern.

 Always adjust the **tracking** before adjusting the **phase**

System menu

- To display the menus, press MENU  on the remote control or the projector control panel.
- Use the  and  keys to select the **System menu** page,

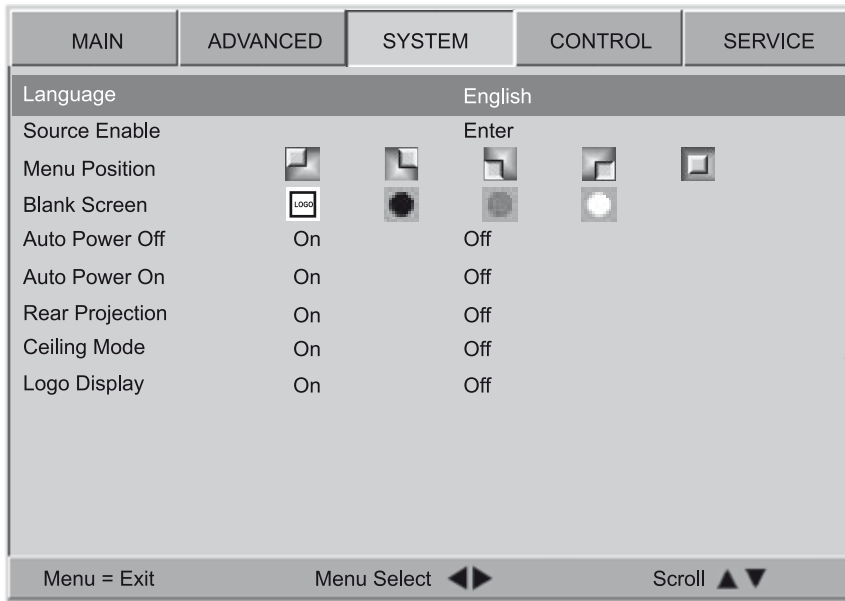







- To select a menu item, use the  and  keys until the item is highlighted.

Language

This product is available only in English at present.

Notes

 To select a different menu, press MENU  once or twice, so that no items are highlighted, then use the  and  keys to select a different page.

 To exit from the menus completely, you may need to press  up to three times.

System menu continued**Source Enable**

- Press ENTER or SELECT.

The **Source Enable** submenu will appear:

MAIN	ADVANCED	SYSTEM	CONTROL	SERVICE
HDMI 1		<input checked="" type="checkbox"/> On	<input type="checkbox"/> Off	
HDMI 2		<input checked="" type="checkbox"/> On	<input type="checkbox"/> Off	
RGB		<input checked="" type="checkbox"/> On	<input type="checkbox"/> Off	
Comp 1		<input checked="" type="checkbox"/> On	<input type="checkbox"/> Off	
Comp 2		<input checked="" type="checkbox"/> On	<input type="checkbox"/> Off	
Video		<input checked="" type="checkbox"/> On	<input type="checkbox"/> Off	
S-Video		<input checked="" type="checkbox"/> On	<input type="checkbox"/> Off	

Menu = Exit Adjust ◀▶ Scroll ▲▼

- Use the ▲ and ▼ keys to select from:

HDMI 1**HDMI 2****RGB****Component 1****Component 2****Video****S-Video**



- For each source, use the ◀ and ▶ keys to select from:



On the selected source will be included in an automatic input source search

Off the selected source will not be included in an automatic input source search

- To return to the **System** menu, press MENU  once.

Notes

 To select a different menu, press MENU  once or twice, so that no items are highlighted, then use the ◀ and ▶ keys to select a different page.

 To exit from the menus completely, you may need to press  up to three times.

System menu continued**Menu Position**

- Use the ◀ and ▶ keys to select from:

Top left

Top right

Bottom left

Bottom right

Centre

Blank Screen

This option determines what appears on screen when the projector is searching for a valid input source.

- Use the ◀ and ▶ keys to select from:

Digital Projection logo

Black screen



Blue screen

White screen

Auto Power On

- Use the ◀ and ▶ keys to select from:

On When power is connected, the projector starts up immediately.



Off When power is connected, the projector goes into Standby mode, and does not start until POWER ON  on the remote control or POWER  on the projector control panel is pressed.

Auto Power Off

When the projector is searching for a valid input source, this option determines what appears on screen.

- Use the ◀ and ▶ keys to select from:

On The projector automatically goes into Standby mode if no input source is detected for 20 minutes.

Off The projector stays on until POWER OFF  on the remote control or POWER  on the projector control panel is pressed.

Notes

To exit from the menus completely, you may need to press  up to three times.



Image changes made using the menus will take effect immediately.

System menu continued**Rear Projection**

- Use the ◀ and ▶ keys to select from:
On Projected image is reversed, left to right
Off

Ceiling Mode

- Use the ◀ and ▶ keys to select from:
On Projected image is reversed, top to bottom
Off

Logo Display

- Use the ◀ and ▶ keys to select from:
On The Digital Projection logo is displayed during power up
Off

Notes





To exit from the menus completely, you may need to press  up to three times.







Image changes made using the menus will take effect immediately.

Control menu

- To display the menus, press MENU  on the remote control or the projector control panel.
- Use the  and  keys to select the **Control menu** page,

MAIN	ADVANCED	SYSTEM	CONTROL	SERVICE
1 Key		Enter		
2 Key		Enter		
3 Key		Enter		
4 Key		Enter		
5 Key		Enter		
Trigger 1	Screen	16:9	Theaterscope	4:3 4:3 Narrow RS232
Trigger 2	Screen	16:9	Theaterscope	4:3 4:3 Narrow RS232
Auto-Source	On	Off		



Menu = Exit Menu Select   Scroll  

- To select a menu item, use the  and  keys until the item is highlighted.

Trigger 1 & 2

Trigger 1 Screen trigger output: can be connected to an electrically operated screen, automatically deploying the screen when the projector starts up, and retracting the screen when the projector shuts down.

Trigger 2 Aspect Ratio trigger output: can be used to control screen shuttering for different aspect ratios

- For each **Trigger setting**, use the  and  keys to select from:

Screen trigger occurs when the projector is in RUNNING mode

16:9 trigger occurs when 16:9 aspect ratio is selected





Theaterscope trigger occurs when Theaterscope aspect ratio is selected



4:3 trigger occurs when 4:3 aspect ratio is selected

4:3 Narrow trigger occurs when 4:3 Narrow aspect ratio is selected

RS232 trigger output follows the **On** or **Off** setting specified in a **trig.1** or **trig.2** command received from a PC via the RS232 serial input.

Notes

 To select a different menu, press MENU  once or twice, so that no items are highlighted, then use the  and  keys to select a different page.

 To exit from the menus completely, you may need to press  up to three times.

 For more information about the trigger input, see **Control connections** in section **6. Appendix**.

 For more information about RS232 commands, see **Remote communications protocol** in section **6. Appendix**.

Control menu continued

Auto Source

- Use the ◀ and ▶ keys to select from:

On projector searches for an alternative input source when the current input source is disconnected

Off projector shows a 'blank' screen when the current input source is disconnected

Keys 1 to 5

The 1 to 5 keys on the remote control can each be programmed to switch to one of the seven input sources.

- Use the ▲ and ▼ keys to select a Key, then press ENTER or SELECT.

The **Key** submenu will appear:

MAIN	ADVANCED	SYSTEM	CONTROL	SERVICE
1 Key		HDMI 1	<input checked="" type="checkbox"/>	
2 Key		HDMI 2	<input type="checkbox"/>	
3 Key		RGB	<input type="checkbox"/>	
4 Key		Comp 1	<input type="checkbox"/>	
5 Key		Comp 2	<input type="checkbox"/>	
Trigger 1		Video	<input type="checkbox"/>	
Trigger 2		S-Video	<input type="checkbox"/>	
Auto-Source				

Menu = Exit Adjust ◀▶ Scroll ▲▼

- Use the ▲ and ▼ keys to select from:

HDMI 1

HDMI 2

RGB

Component 1

Component 2



Video



S-Video

- Press ENTER or SELECT to confirm your selection.
- Press MENU  to return to the **Control** menu and select another key.

Notes



 To set what a 'blank' screen looks like, use the **Blank Screen** setting in the **System** menu.





 To select a different menu, press MENU  once or twice, so that no items are highlighted, then use the ◀ and ▶ keys to select a different page.

 To exit from the menus completely, you may need to press MENU  up to three times.



 If a source has been disabled in the **System** menu, then a key programmed with that source will have no effect.

Service menu

- To display the menus, press MENU  on the remote control or the projector control panel.
- Use the  and  keys to select the **Service menu** page,

MAIN	ADVANCED	SYSTEM	CONTROL	SERVICE
Model Name		M-Vision 1080p 260		
Serial Number		C932XXXX00238		
Software Version		MD02-GD03-0002-000102		
Active Source		Comp 1		
Pixel Clock		13.50 MHz		
Signal Format		576i/50Hz		
H/V Refresh Rate		H: 15.625 KHz V: 50Hz		
Runtime Hours		29 HRS		
Factory Reset		Enter		
Blue Only		On	Off	
Test Patterns		On	Off	
Altitude		Low	High	
Menu = Exit   Scroll  				

The first eight items are for information only, and cannot be changed.



- To select a menu item, use the  and  keys until the item is highlighted.

Factory Reset



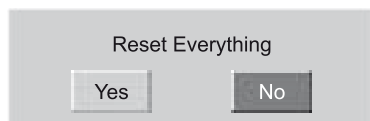

- Press ENTER or SELECT to request a Factory Reset.



The following message will be displayed.



- Use the  and  keys to select from:
 - Yes** all settings will be restored to factory defaults
 - No**
- Press ENTER or SELECT to confirm your choice.

Notes

 To select a different menu, press MENU  once or twice, so that no items are highlighted, then use the  and  keys to select a different page.

 To exit from the menus completely, you may need to press  up to three times.

 **Restore Defaults will restore all settings to factory defaults.**

If you are not sure this is what you want to do, then either:

make a record of all settings first

or
select **No**, then press ENTER or SELECT

Service menu continued**Blue Only**

This is useful for color-calibrating the projector or other video components.

- Use the ◀ and ▶ keys to select from:

- On** only the blue signal is displayed - green and red are turned off
- Off** all three signals - red, green and blue - are displayed

Test Patterns

- Use the ◀ and ▶ keys to select from:

Test Pattern Off**White****Black****Red****Green****Blue****Cyan****Magenta****Yellow****Chequerboard****Greyscale****Alignment grid**



- To turn the test pattern **Off**, press any other key.

Altitude

For use at high altitudes where the air is thinner, the fan speed can be increased.

- Use the ◀ and ▶ keys to select from:

Low normal speed fan**High** high speed fan**Notes**

 To exit from the menus completely, you may need to press  up to three times.

 Image changes made using the menu will take effect immediately.

 Some menu items may be greyed out - unavailable due to the effect of settings made in other menus, or due to the type of input signal.

 If the projector frequently overheats when used in a high altitude environment, then it may help to use the High Altitude setting.

In most cases, the Low Altitude setting should be satisfactory.

5. Maintenance

Contents

Changing the lamp module	5.2
Cleaning the fans	5.3

Changing the lamp module

- Turn the power OFF and allow the lamp to cool for 5 minutes.
- Unscrew the captive finger screw securing the lamp door, and remove the door.

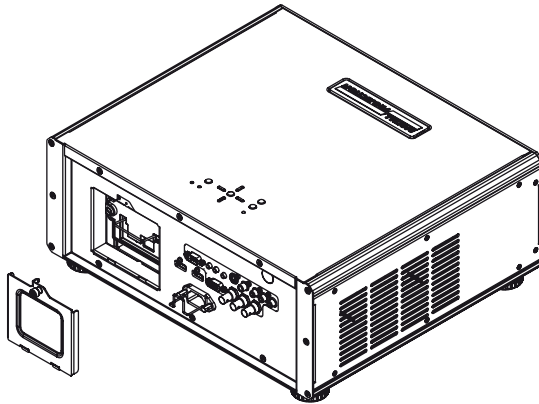

- Unscrew the two cross-head screws securing the lamp module to the projector
- Lift the wire handle up and use it to pull out the lamp module.

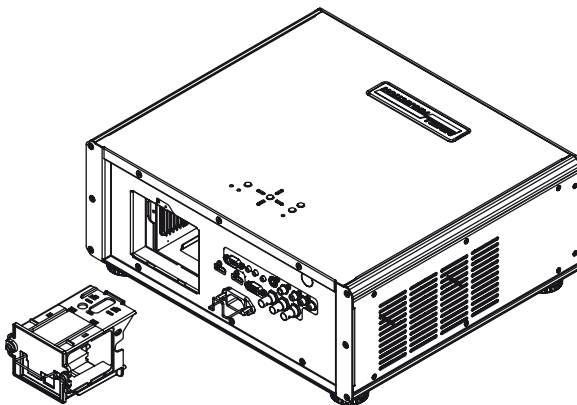



- Fit a new lamp module, pushing it firmly into place.
- Tighten the two cross-head screws.
- Locate the two lugs at the bottom of the lamp door into the slots, and re-fit the door. Tighten the finger screw.

Notes

 **Always allow the lamp to cool for 5 minutes before:**

- disconnecting the power
- moving the projector
- changing the lamp

 **There are no user-serviceable parts inside the lamp module. The whole module should be replaced.**

 **Only lamps supplied by Digital Projection and intended for this projector should be used. Fitting any other lamp could damage both projector and lamp, and will invalidate the warranty.**

 *At the end of life, the lamp will not strike, and the **Issue** indicator on the control panel will flash red. (Typical lamp life is 2000 hours)*

 **Do not use the lamp for more than 2000 hours, as this may cause serious lamp failure, damage the lamp module and cause extra cost on replacement.**

 **Take care not to touch the glass surface of the lamp module. If you do accidentally touch the glass, it should be cleaned before use.**

 **HID lamps produce high intensity light. Do not look directly at the light coming from the lamp housing or the lens.**

 *Opening the lamp door will switch the projector OFF. The projector cannot be operated until the door is fully closed.*

Cleaning the fans

- Turn the power OFF and wait until the fans stop.
- Use a vacuum cleaner to clean the inlet and outlet fans, as shown below.

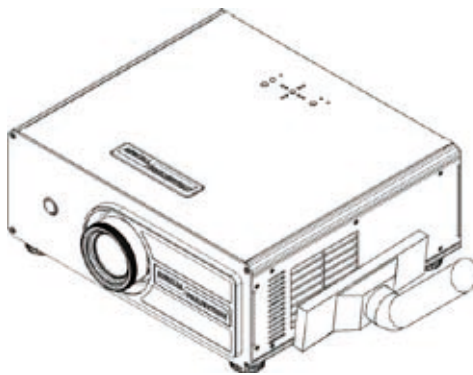
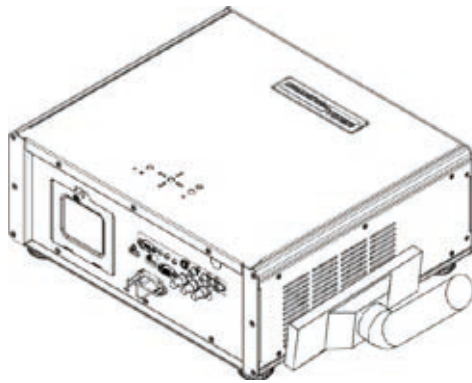

Notes



Always switch the projector OFF before cleaning the fans.



The fans should be cleaned regularly:

- *In a clean environment such as an office, after 500 hours.*
- *In a dusty or smoky environment such as a theatre or public area, more frequent cleaning may be necessary.*

6. Appendix

Contents

Troubleshooting	6.2
Error codes	6.4
Specifications	6.5
Part numbers.....	6.5
Optical	6.5
Electrical	6.6
Physical	6.6
Dimensions	6.7
Video formats supported	6.8
Input connections	6.10
HDMI 1 & 2 inputs.....	6.10
Composite video input.....	6.10
S-Video input.....	6.10
RGB input	6.11
Component 1 input.....	6.11
Component 2 input.....	6.11
Control connections	6.12
Wired Remote control connection	6.12
Trigger 1 & 2 output	6.12
Serial control input	6.12
Null-modem cable	6.12
Serial port settings	6.12
Remote communications protocol	6.13
Introduction	6.13
Key Commands.....	6.13
Example	6.13
The commands	6.13
Operation Commands	6.15
Example	6.15
The commands	6.15

Troubleshooting

Problem	Possible solutions
The red ISSUE indicator is illuminated continuously or flashing.	Check the Error codes detailed on the next page.
The projector will not power up.	Check that the mains plug is plugged in and that the mains supply is switched on. Check that the lamp door is closed properly. Check any external fuses or breakers.
The projector will not power up shortly after being switched off.	To protect the lamp, the projector cannot be switched on when in it is in cool-down mode. Wait until the power indicator stops flashing blue, and the standby indicator shows amber.
The projector shuts down after it has been in use for some time.	The projector may be overheating. Check that the air inlets and outlets are clear of any obstruction. See section 5. Maintenance, Cleaning the optional filter It is possible to increase the speed of the fans for use in a high altitude environment: See section 4. Controlling the projector, System menu
No image is displayed.	See section 5. Maintenance, Changing the lamp Check that the input source is switched on and connected to the projector correctly. Check that the correct image source is selected. Check that the brightness and contrast settings are set correctly. See section 4. Controlling the projector, Using the control keys and Main menu The projector may be overheating. Check that the air inlets and outlets are clear of any obstruction.
The image does not fit the screen correctly.	Check that the projector and screen size are positioned correctly, and that the zoom is adjusted correctly. See section 2. Installation, Screen size vs throw distance Check the aspect ratio setting. See section 4. Controlling the projector, Main menus
Uneven image quality.	Check that the projector is parallel to the screen. Check that the screen is flat, and securely mounted.

Problem	Possible solutions
Image is split or otherwise scrambled.	Check that the image source is not set to progressive scan.
Image is blurred.	Check that the lens is focussed correctly.
Image is too bright, and lacks definition in the bright areas.	Decrease the contrast setting. See section 4. Controlling the projector, Using the control keys and Main menu
Image appears 'washed out' and is too bright in the dark areas	Decrease the brightness setting. See section 4. Controlling the projector, Using the control keys and Main menu
Colors in the image are swapped. for example, reds appear blue or vice versa.	Check that the Component signals are connected correctly. See Section 4. Installation, Connecting the projector.
Projector does not respond to control commands from a computer.	Check that the serial cable is connected correctly. Check that the baud rate is set correctly. See this section 6. Appendix, Connections Check that the correct control codes are being used. See this section 6. Appendix. Serial communications protocol
Projector does not respond to control commands from the remote control.	Check that the infra red windows at the front and rear of the projector or on the IR repeater are not obstructed. Check that the batteries are in good condition. If you are using an IR repeater, check that the cable is connected properly at both ends, and that the cable is not damaged. See section 4. Controlling the projector, The remote control
	In the event that this troubleshooting guide has not solved the problem, then contact your Digital Projection dealer or service centre.

Error codes

If the projector detects an error, the red Issue indicator will flash, as shown in the chart below.

For example, if the lamp door is left open, the red indicator will flash twice followed by a pause, then the sequence will repeat until the error condition is corrected.

Notes

	Amber (Standby)	Blue (Power)	Red (Issue)
Standby			
Cooling / Warm up			
Power on / Normal			
Lamp fail			
Lamp door open			
Fan fail			
Over temperature			
System error			

Specifications

Part numbers

Projector	
0.73:1 fixed lens	109-729
1.56–1.86:1 zoom lens	109-658
1.85–2.40:1 zoom lens	109-680
Power cable 10A, Europe	102-163
Power cable 13A, North America	102-165
Power cable 10A, United Kingdom	102-180
Remote control	109-685
User manual on CD	110-288
Important Information	110-287
Getting Started Guide	110-286

Replacement parts

Lamp module	109-682
0.8x converter lens	109-727
1.25x converter lens	109-735

Optical

Digital Light Processor	1 x 0.95" Texas Instruments DMD™, resolution 1920 x 1080 pixels
Colour wheel	5-segment: Red/Yellow/Green/White/Blue (3x)
Contrast Ratio	2000:1 (±10%)
Colour temperature	Native: 7500°K (±1500°K), adjustable: 5500°K - 9300°K
Pixel fill factor	87%
Lamp power	260W
Lamp life (typical)	2000 hours
Brightness	3500 ANSI lumens (±10%)
Uniformity	85%
Focus range	
0.73:1 Fixed lens	to be confirmed
1.56–1.86:1 zoom lens	2–7m (6.6 - 23ft)
1.85–2.40:1 zoom lens	2.5–10m (8.2 - 32.8ft)
Image width	
0.73:1 fixed lens	to be confirmed
1.56–1.86:1 zoom lens	0.86 to 5.6m (2.8 - 18.4ft) depending on lens converter
1.85–2.40:1 zoom lens	0.81 to 6.86m (2.7 - 22.2ft) depending on lens converter

Lens aperture

0.73:1 fixed lens	F/2.5
1.56–1.86:1 zoom lens	F/2.5–2.76
1.85–2.40:1 zoom lens	F/2.17–2.46

Lens shift (zoom lenses only)

Vertical	± 0.6 H (120%)
Horizontal	± 0.3 W (60%)

Electrical

Inputs	HDMI x 2, RGB, Component x 2, Video, S-Video
Pixel clock (digital)	up to 165MHz
Bandwidth (analog)	200MHz
Control inputs	1 x RS232 serial: 38400 baud, 8 bits, 1 stop bit, no parity 1 x remote control
Mains voltage	100-240 VAC ±10%, 47-63Hz (single phase)
Power consumption	
110V	347W in Running mode, 1.9W in Standby
240V	331W in Running mode, 2.5W in Standby
International Regulations	Meets FCC Class B requirements Meets EMC Directives (EN 55022, EN 55024) Meets Low Voltage Directive (EN60950)
Indicators	Power, Standby, Issue (Fault)

Physical

Temperature	
Operating	0 to 35°C
Storage	-20 to 60°C
Thermal Dissipation	1500 BTU/hr
Humidity	
Operating	20% to 90% non condensing
Storage	10% to 90%
Altitude	
Operating	up to 10,000 feet
Storage	up to 40,000 feet
Weight	9 kg (20 lbs)
Noise level	< 35 dB



Specifications are subject to change without notice.

Dimensions

All dimensions in mm
unless otherwise stated

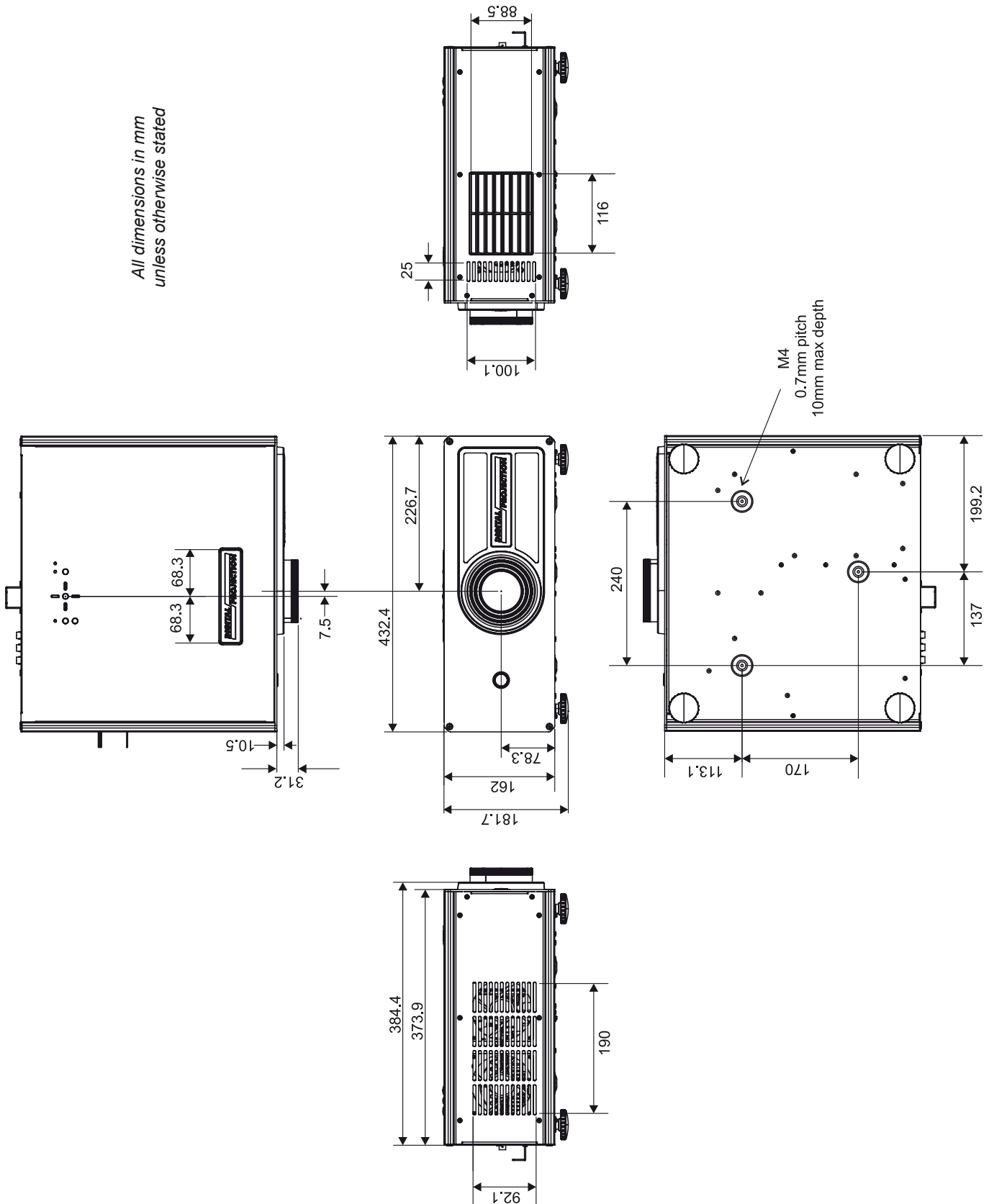

Video formats supported

Signal Type	Resolution	Frame Rate	HDMI	RGB	Component 1: RGB	Component 1: Y/Pr/Pb Y/Cr/Cb	Component 2: Y/Pr/Pb Y/Cr	Video	S-Video	Reference
PC	640x480	59.94	x	x	x					VESA DMT
	640x480	74.99	x	x	x					VESA DMT
	640x480	85	x	x	x					VESA DMT
	800x600	60.32	x	x	x					VESA DMT
	800x600	75	x	x	x					VESA DMT
	800x600	85.06	x	x	x					VESA DMT
	848x480	47.95	x	x	x					VESA CVT
	848x480	59.94	x	x	x					VESA CVT
	1024x768	60	x	x	x					VESA DMT
	1024x768	75.03	x	x	x					VESA DMT
	1024x768	85.03	x	x	x					VESA DMT
	1024x768	70.1	x	x	x					VESA DMT
	1280x720	47.95	x	x	x					VESA GTF
	1280 x 768	60	x	x	x					VESA DMT
	1280 x 768	60	x	x	x					VESA DMT Reduced Blanking
	1280 x 768	75	x	x	x					VESA DMT
	1280 x 768	85	x	x	x					VESA DMT
	1280 x 800	50	x	x	x					VESA DMT
	1280 x 800	60	x	x	x					VESA DMT
	1280 x 800	75	x	x	x					VESA DMT
	1280x1024	60.02	x	x	x					VESA DMT
	1280x1024	75.02	x	x	x					VESA DMT
	1280x1024	85.02	x	x	x					VESA DMT
	1440 x 900	60	x	x	x					VESA DMT
	1440 x 900	75	x	x	x					VESA DMT
	1400 x 1050	60	x	x	x					VESA DMT
	1400 x 1050	75	x	x	x					VESA DMT
	1600x1200	60	x	x	x					VESA DMT
	1920x1080	47.95	x	x	x					VESA CVT
	1600 x 1200	60	x	x	x					VESA DMT
	1920 x 1200	60	x	x	x					VESA DMT Reduced Blanking
	1680x1050	59.94	x	x	x					VESA CVT
Apple Mac	640x480	66.59	x	x	x					VESA DMT
	832x624	74.54	x	x	x					VESA DMT

Signal Type	Resolution	Frame Rate	HDMI	RGB	Component 1: RGB	Component 1: Y/Pr/Pb Y/Cr/Cb	Component 2: Y/Pr/Pb Y/Cr	Video	S-Video	Reference
NTSC	NTSC (M, 4.43)	59.94						x	x	ITU-R BT.1700, SMPTE 170M
PAL	PAL (B,G,H,I)	50						x	x	ITU-R BT.1700
	PAL (N)	50						x	x	ITU-R BT.1700
	PAL (M)	59.94						x	x	ITU-R BT.1700
SECAM	SECAM (M)	50						x	x	ITU-R BT.1700
	480i	59.94	x			x	x			SMPTE 125M, CEA-861-D
	576i	50	x			x	x			ITU-R BT.601, CEA-861-D
EDTV	480p	59.94	x	x	x	x	x			SMPTE 293M, CEA-861-D
	576p	50	x	x	x	x	x			ITU-R BT.1358, CEA-861-D
HDTV	1035i	60	x	x	x	x	x			SMPTE 260M
	1080i	50	x	x	x	x	x			SMPTE 274M, CEA-861-D
	1080i (Aus)	50	x	x	x	x	x			SMPTE 295M
	1080i	59.94	x	x	x	x	x			SMPTE 274M, CEA-861-D
	1080i	60	x	x	x	x	x			SMPTE 274M, CEA-861-D
	720p	50	x	x	x	x	x			SMPTE 296M, CEA-861-D
	720p	59.94	x	x	x	x	x			SMPTE 296M, CEA-861-D
	720p	60	x	x	x	x	x			SMPTE 296M, CEA-861-D
	1080p	23.98	x	x	x	x	x			SMPTE 274M, CEA-861-D
	1080p	24	x	x	x	x	x			SMPTE 274M, CEA-861-D
	1080p	25	x	x	x	x	x			SMPTE 274M, CEA-861-D
	1080p	29.97	x	x	x	x	x			SMPTE 274M, CEA-861-D
	1080p	30	x	x	x	x	x			SMPTE 274M, CEA-861-D
	1080p	50	x	x	x	x	x			SMPTE 274M, CEA-861-D
	1080p	59.94	x	x	x	x	x			SMPTE 274M, CEA-861-D
	1080p	60	x	x	x	x	x			SMPTE 274M, CEA-861-D

Input connections

HDMI 1 & 2 inputs

19 way type A connector

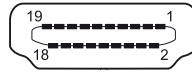

pin view of panel connector

- 1 TMDS Data 2+
- 2 TMDS Data 2 Shield
- 3 TMDS Data 2-
- 4 TMDS Data 1+
- 5 TMDS Data 1 Shield
- 6 TMDS Data 1-
- 7 TMDS Data 0+
- 8 TMDS Data 0 Shield
- 9 TMDS Data 0-
- 10 TMDS Clock+
- 11 TMDS Clock Shield
- 12 TMDS Clock-
- 13 CEC
- 14 not connected
- 15 SCL (DDC Clock)
- 16 SCA (DDC Data)
- 17 DDC/CEC Ground
- 18 +5 V Power
- 19 Hot Plug Detect

Composite video input

1 x 75 ohm BNC

PAL or NTSC video



S-Video input

4 pin mini-DIN



pin view of female connector

- 1 Y Ground
- 2 C Ground
- 3 Luminance (Y)
- 4 Chrominance (C)

Notes

RGB input

15 way D-type connector

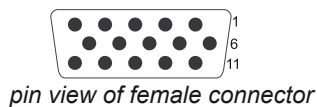

- 1 R
- 2 G
- 3 B
- 4 unused
- 5 Digital Ground (H Sync)
- 6 R Ground
- 7 B Ground
- 8 G Ground
- 9 +5v
- 10 Digital Ground (V Sync/DDC)
- 11 unused
- 12 SDA
- 13 H Sync
- 14 V Sync
- 15 SCL

Notes

Component 1 input

3 x RCA phono connectors



RGB	YPbPr	YCbCr
Red	Pr	Cr
Green + Sync	Y	Y
Blue	Pb	Cb



In most cases, the Auto setting will determine the correct color space to use. If it does not, you can select the appropriate setting manually.

To select between RGB and YPrPb signals, see Advanced Menu, in 4. Controlling the Projector.

Component 2 input

3 x 75 ohm BNC



YPbPr	YCbCr
Y	Y
Pb	Cb
Pr	Cr

Control connections

Wired Remote control connection

3.5mm mini jack

- Tip Power
- Ring Signal
- Sleeve Ground

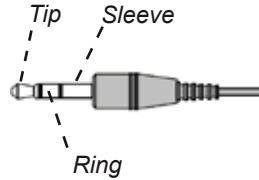

Trigger 1 & 2 output

3.5mm mini jack

- Tip Signal
- Sleeve Ground

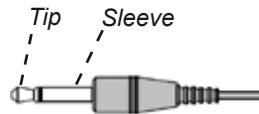

Serial control input

- 1 unused
- 2 Received Data (RX)
- 3 Transmitted Data (TX)
- 4 unused
- 5 Signal Ground
- 6 unused
- 7 unused
- 8 unused
- 9 unused

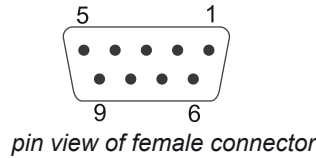

Null-modem cable

(used to connect the projector to a modem)

RX	2	---	3	TX
TX	3	---	2	RX
GND	5	---	5	GND

Serial port settings

- Baud rate 38400 bps
- Data length 8 bits
- Stop bits one
- Parity none
- Flow control none

Notes

 Trigger outputs are normally at 0V, and rise to +12V when triggered.

 The projector is a DCE, so use:

- a straight cable to connect to a computer, or
- a null-modem cable as shown here to connect to another DCE such as a modem.

Remote communications protocol

Introduction

The projector can be controlled by using an external control system or a PC via an RS232 serial interface, using a terminal-emulation program, such as HyperTerminal.

There are 2 types of commands:

- Key commands
- Operation commands

All commands consist of ascii text strings starting with 2 letters:

- ky for key commands.
- op for operations commands.

All commands end with an ascii Carriage Return character.

Key Commands











Key commands are used to simulate remote control key presses, and use the following format:

ky <keyname> [CR]

Example

ky pow.on [CR] simulates the POWER ON key being pressed.

The commands

Code transmitted	<keyname>		Description
0x01	pow.on		Turn power on.
0x09	pow.off		Turn power off.
0x15	menu		Bring up or cancel menu display.
0x17	enter		Keypad enter.
0x18	cur.down		Keypad down arrow.
0x1A	cur.up		Keypad up arrow.
0x1D	cur.left		Keypad left arrow.
0x1F	cur.righ		Keypad right arrow.
0x80	bright		Bring up or cancel brightness slide bar.
0x81	contrast		Bring up or cancel contrast slide bar.

















Notes



Details of how to connect to the projector, using the serial control input, can be found earlier in this section.



Note: in the example, spaces are included for clarity, but are not necessary in the actual command.

Code transmitted	<keyname>		Description
0x82	sharp		Bring up or cancel sharpness slide bar.
0x83	nr		Bring up or cancel noise reduction slide bar.
0x85	gam.sw		Switch to the next gamma value.
0x8B	src.1		Switch the active source to source 1.
0x8C	src.2		Switch the active source to source 2.
0x8D	src.3		Switch the active source to source 3.
0x8E	src.4		Switch the active source to source 4.
0x8F	src.5		Switch the active source to source 5.
0x93	osc.sw		Switch to the next Overscan mode.
0x98	mem.1		Recall user memory associated with the User Memory A key.
0x99	mem.2		Recall user memory associated with the User Memory B key.
0x9A	mem.3		Recall user memory associated with the User Memory C key.
0x9D	asp.sw		Switch to the next aspect ratio setting.
0xA3	bcolor.sw		Switch Brilliant Color on or off.
0xAA	ctemp.sw		Switch to the next colour temperature value.
0xAD	pattern.sw		Switch to the next test pattern.

Operation Commands

Operation commands are used to simulate menu operations and determine the settings of the projector, and use the following format:

op <operation> <command> [CR]

The <command> string can take one of the following formats:

	<command>	Description
Set	= <value>	Makes the setting take that value.
Get	?	Asks what the current value is. The value is returned as an ascii text string.
Increment	+	Adds 1 to the current value.
Decrement	-	Subtracts 1 from the current value.
Execute	(none)	Performs an action.

Example

op aspect =1 [CR] sets the aspect ratio to Theaterscope.

op aspect ? [CR] asks what is the current aspect ratio.

op bright + [CR] increments the brightness setting.

op resync [CR] commands the projector to attempt to re-synchronise to the current input source.

Notes



Note: in the examples, spaces are included for clarity, but are not necessary in the actual command.

The commands

Operation	<command>	Values	Notes
aspect	= ?	0 = 16:9 1 = Theaterscope 2 = 4:3 3 = 4:3 Narrow 4 = Native	
memory	= ?	0 = Preset A 1 = Preset B 2 = Preset C 3 = Preset D 4 = Default	
save.mem	=	0 = Preset A 1 = Preset B 2 = Preset C 3 = Preset D	
bright	= ? + -	0 - 200	
contrast	= ? + -	0 - 200	
saturat	= ? + -	0 - 200	
tint	= ? + -	0 - 200	
sharp	= ? + -	0 - 200	
noise.thresh	= ? + -	0 - 200	
nr.simple	= ? + -	0 - 200	
nr.mode	= ?	0 = Simple 1 = Advanced	

Operation	<command>	Values	Notes
nr.general	= ? + -	0 - 200	
block.reduct	= ? + -	0 - 200	
mosq.noise	= ? + -	0 - 200	
overscan	= ?	0 = Off 1 = Crop 2 = Zoom	
source.sel	= ?	0 = HDMI 1 1 = HDMI 2 2 = RGB 3 = YPrPb 1 4 = YPrPb 2 5 = S-Video 6 = Video	
resync	(execute)		
color.space	= ?	0 = Auto 1 = YPbPr (= REC709) 2 = YCbCr (= REC601) 3 = RGB-PC 4 = RGB-Video	
video.stand	= ?	0 = Auto 1 = NTSC 2 = PAL 3 = SECAM	
gamma	= ?	0 = CRT 1 = Film 2 = Video 3 = Punch 4 = Graphics	
color.temp	= ?	0 = 5500K 1 = 6500K 2 = 7500K 3 = 9300K	
dlp.frame	= ?	0 = Auto 2 = 48 Hz 3 = 50 Hz 4 = 60 Hz	
color.gamut	= ?	0 = Auto 1 = REC709 2 = SMPTE C 3 = EBU 4 = Native	
bcolor	= ?	0 = Off 1 = On	
red.off	= ? + -	0-200	
green.off	= ? + -	0-200	
blue.off	= ? + -	0-200	
red.gain	= ? + -	0-200	
green.gain	= ? + -	0-200	
blue.gain	= ? + -	0-200	
vert.pos	= ? + -	0-200	
horiz.pos	= ? + -	0-200	

Operation	<command>	Values	Notes
phase	= ? + -	0-200	
tracking	= ? + -	0-200	
sync.level	= ? + -	0-200	
menu.pos	= ?	0 = Top left 1 = Top right 2 = Bottom left 3 = Bottom right 4 = Centre	
blank.screen	= ?	0 = Black 1 = Blue 2 = White 3 = Logo	
auto.pow.off	= ?	0 = Off 1 = On	
auto.pow.on	= ?	0 = Off 1 = On	
rear.proj	= ?	0 = Off 1 = On	
ceil.mode	= ?	0 = Off 1 = On	
logo.disp	= ?	0 = Off 1 = On	
trig.1	= ?	0 = Screen 1 = 16:9 2 = Theaterscope 3 = 4:3 4 = 4:3 Narrow 5 = RS232 6 = On 7 = Off	0: Trigger occurs when the projector is in RUNNING mode
trig.2	= ?	0 = Screen 1 = 16:9 2 = Theaterscope 3 = 4:3 4 = 4:3 Narrow 5 = RS232 6 = On 7 = Off	0: Trigger occurs when the projector is in RUNNING mode
auto.source	= ?	0 = Off 1 = On	
model.name	?	<string>	
ser.number	?	<string>	
soft.version	?	<string>	
act.source	?	0 = HDMI 1 1 = HDMI 2 2 = RGB 3 = YPrPb 1 4 = YPrPb 2 5 = S-video 6 = Video	
h.refresh	?	<number>	KHz
v.refresh	?	<number>	Hz

Operation	<command>	Values	Notes
pixel.clock	?	<number>	MHz
signal	?	<string>	
lamp.hours	?	<number>	
total.hours	?	<number>	
environment	?	<string>	Temperatures
lamp.reset	(execute)		
fact.reset	(execute)		
blue.only	=	0 = Off 1 = On	
pattern	=	0 = White 1 = Black 2 = Red 3 = Green 4 = Blue 5 = Cyan 6 = Magenta 7 = Yellow 8 = Chequerboard 9 = Greyscale 10 = Alignment Grid 11 = Off	
altitude	= ?	0 = Low 1 = High	
status.check	?	0 = standby mode 1 = warm up mode 2 = running mode 3 = cooling mode 4 = error	

