

VOXOA

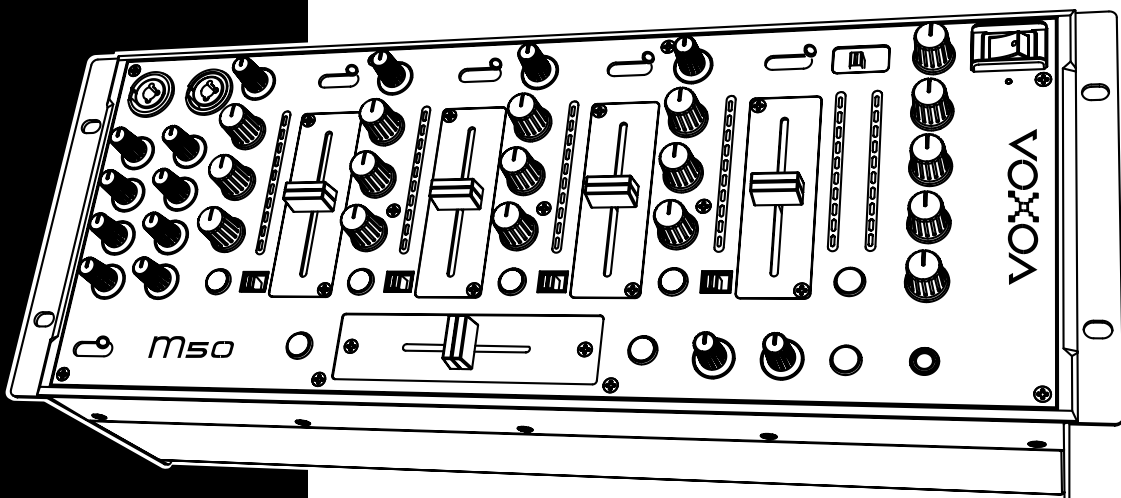

M50

4-Channel Mixer
四通道混音器

User Manual
使用说明书

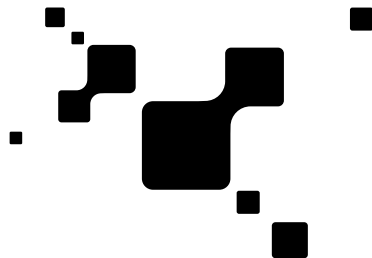

中文

重要安全指示	04
产品主要特色	06
部件名称与功能	08
前面板	08
后背板	12
连接方式	14
规格	16

ENGLISH

IMPORTANT SAFETY INSTRUCTIONS	18
MAIN FEATURES	20
PART NAMES AND FUNCTIONS	21
FRONT PANEL	21
REAR PANEL	26
CONNECTIONS	28
SPECIFICATION	30

重要安全指示

1. 阅读说明书 - 操作本产品前应先阅读所有安全性及操作说明。
2. 保留说明书 - 安全性及操作说明应妥善保存供未来参考用。
3. 留心警告 - 所有在本产品及操作说明上的警告都要遵守。
4. 参照说明书 - 需参照所有操作及使用说明。
5. 水和湿气 - 在操作本产品时绝对不要靠近水-例如靠近浴缸、脸盆、洗碗槽、洗衣盆、游泳池、及在潮湿地下室等等。禁止将装有异体的容器，例如花瓶，酒瓶等至于本产品上。
6. 移动平台及固定台面 - 本产品只能使用在制造商所建议的移动平台及固定台面。本产品与移动平台的组合在移动时应特别注意。突然地停止，过大的外力及不平衡的表面，都会造成本产品在移动平台上翻覆。
7. 墙壁或天花板架置 - 本产品应只参照制造商所建议的方式来架置在墙壁或天花板上。
8. 高温 - 本产品应远离热气来源，例如散热器、暖器、火炉或者其他会产生高温的用品(包含扩大机)。
9. 电源 - 本产品只能照电压标签所示来操作。如果你不确定你住家的电源的种类，请咨询你的产品卖家或当地电力公司。若本产品需要用电池或其他电源，请参照操作说明书。
10. 接地与电极 - 本产品可能供给极化交流电插头。插头只有一个方向插入插座。这是一个安全装置，如果没办法完全插入插座，请试著把插头反方向。如果插头仍无法插入插座，请联络电工来更换插座，请勿毁损安全性为考量的插头。
11. 电源线的保护 - 电源供应线应该妥善规划布线的路径，避免被其他物件所缠绕。应特别注意所使用的插座是否与电源供应线的插头吻合，这插座要靠近本产品的使用地点。
12. 清洁 - 本产品须依照制造商所建议的方式做清洁。清洁本产品应使用柔软的乾布清洁。
13. 交流电供电零件 - 维修完成后在交还产品给使用者前，应使用电阻测量表测量交流电插头及所有暴露在外的金属零件，电阻值应大于100k欧姆。
14. 长时间未使用 - 本产品在长时间未使用的状况下，应将插头拔除。
15. 物体及液体进入 - 小心不要让物体掉入及液体流进本产品里。
16. 损坏需求服务 - 当A.电源线或插头已经毁损；或B.异物或液体掉进本产品；或C.本产品暴露在雨中；或D.操作或功能不正常；或E.本产品被摔落或内部损坏时，应送回合格的服务人员处进行维修。
17. 售后服务 - 除了操作说明书所提到的正常操作外，使用者不应进行其他不当操作或试图自行维修。当本产品有问题时应请教合格的维修服务人员或送回合格的维修站进行维修服务。

重要安全指示

18. 保持本产品**在空气流通的环境中** - 本产品上的散热孔提供流通的空气，以避免本产品在操作时产生过热的现象。这些为保持本产品空气流通的散热孔严禁被阻隔或被其他物品覆盖。特别是较柔软的表面，例如床，沙发及地毯等等。本产品不应被安装在内建的空间内，例如书橱及架子，除非能够依制造产商所规范的空气流通指示建构。
19. **连接安装** - 请勿安装非本产品制造商所建议的连接器材，以避免本产品遭受损害。
20. **配件** - 请勿将本产品放置在不稳定的移动推车，三角架，支撑架或桌子上。本产品可能会掉落因而使小孩或是成人受伤，并且本产品会受到严重的损害。只能使用制造商所建议的移动推车，三角架，支撑架或桌子，或是与本产品一起销售的配件。必须依制造商指示安装本产品，并且安装的配件必须使用制造商所建议的。
21. **闪电** - 为保护本产品在风雨期间不受到闪电的影响及侵害，当本产品长时间不使用时将插头拔除，并拆除天线。这将保护本产品免于受到闪电及电源突然增加的损害。
22. **替换零件** - 当需要替换零件时，请确保维修技术人员使用制造商所指定的零件或是与原零件具有相同特性的替代品。未经授权的替代零件会导致过热著火，电磁冲击或其他严重的损害。
23. **安全性检查** - 本产品在**在进行维修或任何服务时**，请要求维修服务人员进行安全性检查，以确保本产品在正确地操作状况下。

警告

严禁本产品暴露在下雨及潮湿的环境之中，以降低起火及触电的危险。本产品避免暴露在会滴水及会溅到水的环境中。装有液体的容器绝对禁止放在本产品上，例如酒瓶，花瓶等等。



CAUTION
RISK OF ELECTRIC SHOCK
DO NOT OPEN



注意:严禁打开机盖以降低触电的风险。维修及更换零件请咨询维修中心合格的维修工程师。



三角形中有个箭头的闪电标志是为了警告在产品内部因未绝缘而可能产生的高压电，这高压电会造成触电的危险。



三角形中有个惊叹号是为了提醒使用者重要的操作及维护指示。

注意

为了杜绝触电的危险，请勿使用不合规格的插座。应使用插头能够完全插入插座的插孔。

产品主要特色

M50 是一款专业19吋4U机架式4通道混音器，M50的独特设计专为活动DJ及舞台音响系统所设计，提供各式的演艺场所及活动场合在音乐混音需求的最佳解决方案。支援多种连接方式，有4组Line in与4组 Aux/Phono的输入，3组麦克风输入。输出端有平衡式XRL (可微调)，非平衡式RCA，录音输出(RCA)，BOOTH输出，更特别设计超重低音SUB WOOFER的输出。一组可调整的BOOTH输出，除可用来监听外，更可当做另一主要输出，大幅增加音响系统的扩充性，可延伸控制活动现场不同区块的音量调整。

每通道均有三段等化器与高质量推子

每个通道均有增益控制，三波段的等化器，可针对高频，中频与低频，分别调整。并且使用60mm高质量的通道推子，每个通道推子均可独立拆换。

三组麦克风输入

拥有多达三组麦克风的输入，其中两组麦克风的插口，设计置于前面版，以方便麦克风的连接使用，麦克风插口可是适用XRL及6.3mm，每组麦克风均有独立的音量调整与三段均衡控制。

麦克风人声遮盖(TALKOVER)功能

人声遮盖功能可以在DJ使用麦克风的时候，自动将音乐（通道1~4）音量降低。DJ不需要再调整每个通道的音量，让表演与活动进行得更顺畅。

独立的电平指示

每一通道都有独立的电平指示，由10颗的LED灯所组成，以便于调整每个通道音量的大小与主要输出音量一致，让混音的过程中更为平顺。

高品质的 VCA 交叉推子

VCA(Voltage Controlled Amplifier) 控制的交叉推子，大幅的减少因声音讯号传导所产生的噪音，提升整个声音的品质，通常只用于高端的混音器上。VOXOA了解DJ对品质的需求，特别将VCA交叉推子放入标准规格，提供DJ最高品质的使用经验。

超重低音(Sub woofer)控制

独特的Sub woofer控制设计，可自行调整设定低音的频带，让DJ可随著派对气氛增加或减少 Cutoff Freq.之下的低音音量。特别适用于主动式的低音炮喇叭，或是可用来传递讯号给舞台灯光，由低音讯号来控制灯光的变化。

产品主要特色

推子启动(FADER START)功能

推子启动的功能可以大幅提升DJ在接歌上的准确性与效率，当M50与相容的CD播放机相连接时，就可轻松使用推子启动的功能。M50的推子启动可相容VOXOA的P70、P30、P60等CD播放机。

功能特色

- 19英寸 4U机架式四通道混音器
- 输入: Line x4 (RCA), Aux x4 (RCA), Phono x4 (RCA), 麦克风 x3 (XLR/1/4 Inch Combo x 2, 6.3mm x1)
- 输出: XLR Balanced x1, Unbalanced (RCA) x1, Record (RCA) x1, Booth(6.3mm) x1, 低音炮(6.3mm) x1, 推子启动控制 x2 (3.5mm)
- 每个通道都有三波段等化器
- 所有通道均可指定到交叉推子
- 每个通道均有独立的电平指示
- 45 mm VCA可拆换的交叉推子
- 交叉推子具有推子启动的功能
- 推子启动可相容于VOXOA的CD/MP3播放器
- 可将监听耳机的Cue划分开
- 主要输出可以切换立体声或是单声道
- 重低音单独输出并可调整控制输出频率
- 可控制音量的Booth 输出端子

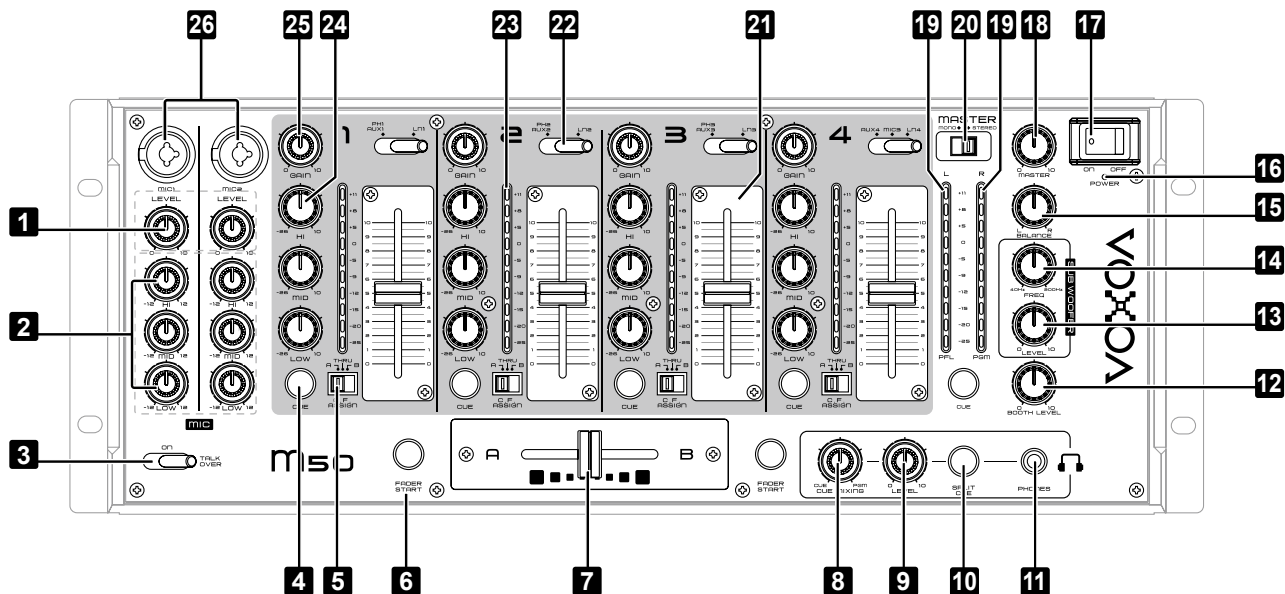

1. 麦克风 1 & 2 电平控制

此旋钮控制调整麦克风1&2的电平。

2. 麦克风音频等化控制

此组旋钮分别控制麦克风 1 及麦克风 2 的频率响应，控制范围由-12dB到+12dB。

高音 - 此旋钮用来调整麦克风输出高频的部分，可控制从-12dB到+12dB(在10KHz下)，旋钮调整至中间的位置，在高频的部分是平坦的。

中音 - 此旋钮用来调整麦克风输出中音频的部分，可控制从-12dB到+12dB(在1KHz下)，旋钮调整至中间的位置，在中音频的部分是平坦的。

低音 - 此旋钮用来调整麦克风输出低音频的部分，可控制从-12dB到+12dB(在100Hz下)，旋钮调整至中间的位置，在低音频的部分是平坦的。

3. 麦克风 开启/关闭/人声遮盖 切换开关

设定控制麦克风的开启与关闭，当开关位置置于人声遮盖(TALKOVER)的位置时，麦克风 1 及麦克风 2 均会启动，原本音乐的音量会自动降低到14dB左右。

4. 启动监听(Cue) 按键

按下所有或其中一个Cue按键，会将音乐来源分别分配至所指定的音轨再经由耳机监听。按下多重Cue按键，可由所选择的音源在监听耳机中造成混音的效果。

5. 交叉推子(Crossfader)分配开关

切换开关到对应的位置，可以选择音轨音源分配到交叉推子的左(A)或是右(B)。当开关切换在中间的位置“THRU”表示音轨音源不受交叉推子的控制。

6. 推子启动按键 (FADER START BUTTON)

此按键用来启动或关闭推子起动的功能。连接相容的音乐播放器此功能才有作用。当使用相容的音乐播放器时，你可以透过交叉推子(Crossfader)来启动播放或是暂停播放。

7. 交叉推子

此推子是用来混合音轨输出讯号A与B，当推子至于最左边的位置时，输出讯号A的音量由主音量来控制。同样的功能也适用于音轨输出讯号B。当推子由左至右(或由右至左)推动时，将分别改变A与B输出讯号的强弱，当推子至于中间时，A与B输出的强度是平衡的。

8. Cue混音控制

当使用耳机监听时，此旋钮的功能用来混音主要输出与Cue输出的比例，当旋钮转到最左，只能听到Cue的部分，当旋钮转到最右，只能听到Program (主要输出)的部分。当你没有监听喇叭只使用监听耳机时，此功能特别有用。

9. Cue音量控制

此旋钮用来控制调整监听耳机的音量，顺时针方向旋转会增加音量的强度。

10. 划分Cue按键

当按下此键时，耳机监听会被划分成单声道Cue (MONO Cue)及单声道主要输出(MONO Master)，单声道Cue(MONO Cue)声音出现在耳机的左边，单声道主要输出(MONO Master) 声音出现在耳机的右边，目的是为了便于调整每一音轨，以配合主声道输出。音量计量器 **19** 左边所显示的是单声道Cue(MONO Cue)，右边所显示的是单声道主要输出(MONO Master)。

11. 耳机插口

此插座用来连接监听耳机与混音器，目的用来监听 Cue的音源。当连接监听耳机时，请先确认Cue的音量调整至最小声。

部件名称与功能

12. Booth电平控制

此旋钮用来控制输出Booth 电平的大小。

13. 重低音/灯光 强度控制

此旋钮用来控制在后面版所连接的重低音喇叭/灯光的强度。

14. 重低音频率控制

此旋钮用来调整控制重低音低音的频率，控制范围由40Hz到200Hz。

15. 主输出左右声道平衡控制

此旋钮用来调整控制输出至左声道及右声道的多寡，当旋钮置中在12点钟方向时，可表现出立体声。

16. 电源开关指示

当电源打开时，红灯亮。

17. 电源开关

此开关为主电源开关。

注意：先完成混音器所有的连接安装，再打开电源开关，另外必须确认功率放大器是关闭的状态。

注意：为了避免损害喇叭，混音器必须最先开启及最后关闭。

18. 主输出控制旋钮

此旋钮用来控制主要输出的音量大小。

注意：为了避免过大的音量而造成喇叭的损害，当要启动本混音器时，请先确定调整主输出音量控制到0的位置。

19. PFL/PGM 电平指示

是用来监看立体声主声道音量输出，或是单声道频道输出及主声道输出电平大小。当在立体声模式(STEREO)时，电平指示的是主要输出的左右声道音量。在单音(MONO)的模式且启动SPLIT CUE的模式下，单声Cue的电平显示在左边的指示，单声主要输出的电平显示在右边的指示。

20. 主要输出立体声/单声 切换开关

利用此开关切换，主要输出为立体声或是单声道。

21. 通道推子

这些推子用来控制指定通道的输出音量。然而，主音量控制是由主输出控制旋钮 **18** 所控制。

22. 音源选择开关

用来切换选择每一音轨的输入音源，每一音轨一次只能指定一种输入音源。

注意：使用唱盘机时，音源选择开关一定必须在“Phono”的位置上。

23. 通道电平指示

显示单一通道调整电平大小及等化器后的输入电平。显示范围从-25dB到+11dB。

24. 通道等化器区块

这些旋钮调整控制所选择通道的频率响应。

高音 - 此旋钮用来调整通道输出高频的部分，可控制从-15dB到+10dB(在13KHz下)，旋钮调整至中间的位置，在高频的部分是平坦的。

中音 - 此旋钮用来调整通道输出中音频的部分，可控制从-25dB到+10dB(在1KHz下)，旋钮调整至中间的位置，在中音频的部分是平坦的。

低音 - 此旋钮用来调整通道输出低音频的部分，可控制从-25dB到+10dB(在70Hz下)，旋钮调整至中间的位置，在低音频的部分是平坦的。

25. 通道电平

用来调整所选择通道的电平大小，从 $-\infty$ 到+14dB。

26. 麦克风插口

这是一个两用的插口，可适用于标准 1/4英吋的插头或是平衡式3针XLR公插头。麦克风的音量由个别的音量控制旋钮所控制 **1**。

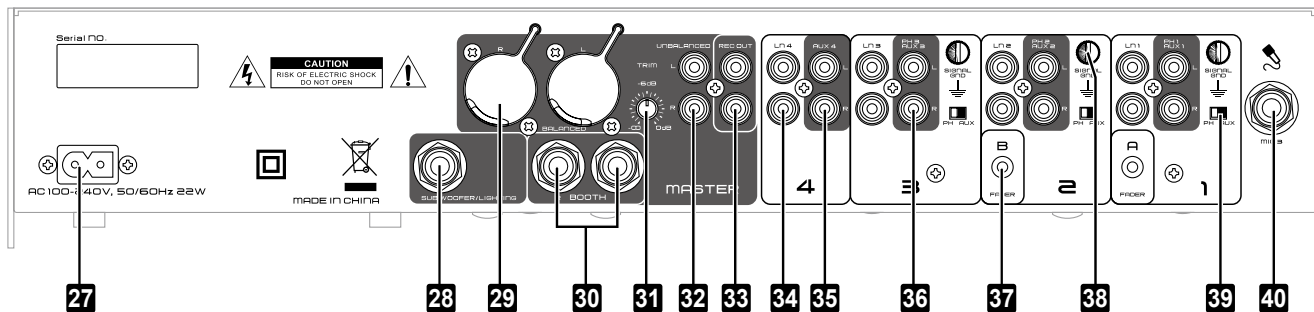

27. 电源连接插座

此电源插座是用来供应主要电源的，透过 - 可拆除式的电源线。

注意：连接上电源供应前，请先确定输入电源符合本混音器上电源供应标签上的说明需求。

警告：电源线若不符合电源插座，切勿试图强迫连接上电源线。

28. 重低音喇叭/灯光 输出插口

这1/4吋的接口，提供一个单声道的输出，此讯号的大小是由重低音音量控制旋钮所控制 **13**。连接此输出至重低音喇叭或是灯光控制器上。

29. 平衡式XLR主音量输出插口

这个3-pin XLR插口送出高电流平衡输出讯号。

注意：这个插口需用于连接推动具有平衡式输入的功率放大器或是音讯设备。或是当讯号电缆线长度超过15英尺时。

30. Booth输出插口

这是一对平衡式的RCA插口，提供平衡式的音量输出，藉由前面版的Booth Level 旋钮 **12** 所控制，这个输出不受主音量输出 **18** 所影响。

31. 主音量输出缩减调整钮

这个旋钮用来削减主输出音量，用以保护所连接的功率放大器或是喇叭免于受到过大的输入讯号而造成的损害。

32. 主音量输出RCA插口

此插口送出一组低电流非平衡式的输出讯号。这组插口建议只能使用在较短的连接线或是串接到另一台混音器。

注意：当连接线超过15英尺时，应使用 平衡式XLR插座 **29**。

33. 录音输出插口

这是一个低电流非平衡式的输出，是专为外接的录音设备所设计，输出音量的控制是藉由每个音轨的音量控制推子 **21** 及音量控制旋钮 **25** 所控制，不受主音量控制旋钮 **18** 所影响。

34. 线性(LINE)输入插口

这组插口是用来连接线性输入所使用，可以连接CD播放器或是卡带播放器。输入的音量由音轨音量控制推子 **21** 所控制。连接时，输入音源选择开关 **22** 必须切换到线性(LINE)的位置。

35. AUX 输入插口

CD播放器，卡带播放器及其他线性乐器，可透过此插口连接，红色的RCA插座代表是右声道，白色的RCA插座代表是左声道。输入音量可经由音轨音量控制 **21** 来调整。音源选择切换开关 **22** 必须切换到“AUX”的位置。

36. PH/AUX 输入插口

输入模式的切换由通道输入PHONO/AUX切换开关 **39** 所控制，装备有MM读取唱针的唱盘(所有DJ唱盘机均使用MM读取唱针)可透过此插口连接，在通道输入PHONO/AUX切换开关 **39**，必须切换到” PHONO” 的位置。CD播放器，卡带播放器及其他线性等级的乐器连接此插座，必须切换通道输入PHONO/AUX切换开关 **39** 在” AUX” 的位置时，才能使用。输入音量可经由通道推子 **21** 所控制。

警告：当音轨输入PHONO/AUX切换开关 **39** 切换位于” PHONO” 位置时，切勿连结CD播放器，卡带播放机等线性等级的设备到此连接插座。这将会严重的危及此混音器。

37. 推子启动控制连接插口

这个插口用来控制“推子起动”的功能，连接相容的CD播放器及本混音器。使用2.5mm MONO的插头来连接相容的CD播放器与混音器。交叉推子的左边(A)控制CH-A的“推子启动”，交叉推子的右边(B)控制CH-B的“推子启动”。进一步了解有关如何使用“推子启动”请参照你所使用的相容CD播放器的说明书”。

38. 接地端子

连接唱盘机时，务必将唱盘机的接地线与此接地端子连接，因为可减低唱针头所造成的哼声及杂讯。

39. 通道输入PHONO/AUX切换开关

此开关用来改变PHONO/AUX个别的电压。

注意：连接唱盘机时，此开关务必切换至 “PHONO” 连接 CD播放机等，此开关务必切换至 “AUX” 。

注意：在切换通道输入选择时，务必要要确认主电源开关 **17** 是关闭的。

40. 麦克风3 插口

此插座用来连接麦克风与混音器，使用1/4英吋的麦克风音讯插头。

连接方式

1. 进行连接时，请确保交流电源关闭。当连接完成时才可将电源打开。
2. 不同质量的连接线会较程度地影响声音的保真度及效果。请使用高质量的音频线。
3. 请勿使用很长的线缆。确保所有插头与插口都已插紧。连接未插紧会导致嗡嗡声，杂音或时断时续的情况产生，可能导致扬声器的损坏。
4. 连接所有输入音源。然后连接外接效果器。连接麦克风及监听耳机。确保所有推子都位在“零”的位置，且设备必须在关闭状态。每次仅连接一根连接线，且在连接时注意M50及其他外部设备的左(L)声道右(R)声道位置。
5. 将音讯输出端与功率放大器和/或卡座及/或MD录音机与/或CD录音机等等，依照所示连接图相连。

注意：每次都应先打开各种音频输入源，如CD播放机，然后打开您的混音器，最后是各功率放大器。关闭时按相反的顺序进行，先是关闭功率放大器，然后混音器，最后为输入设备。

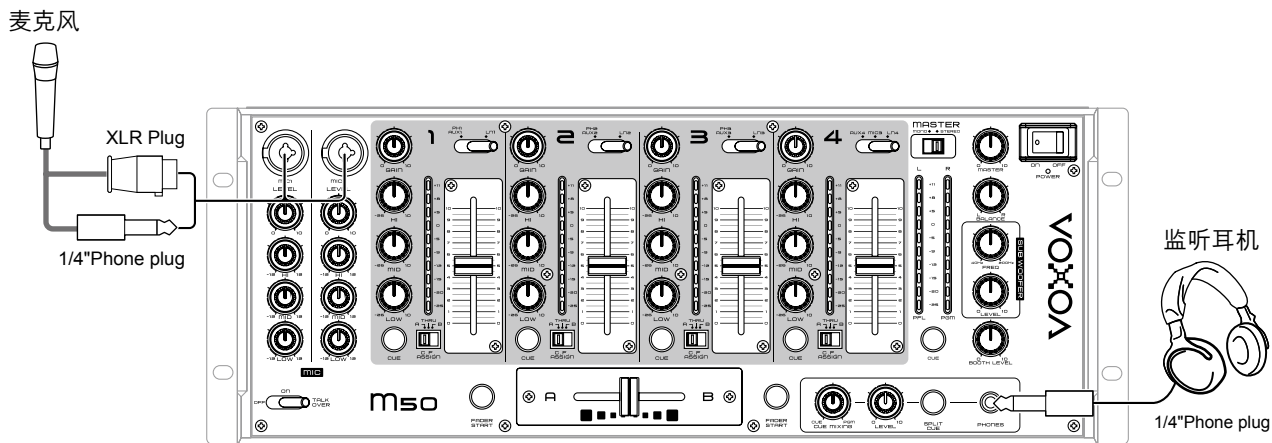

连接方式

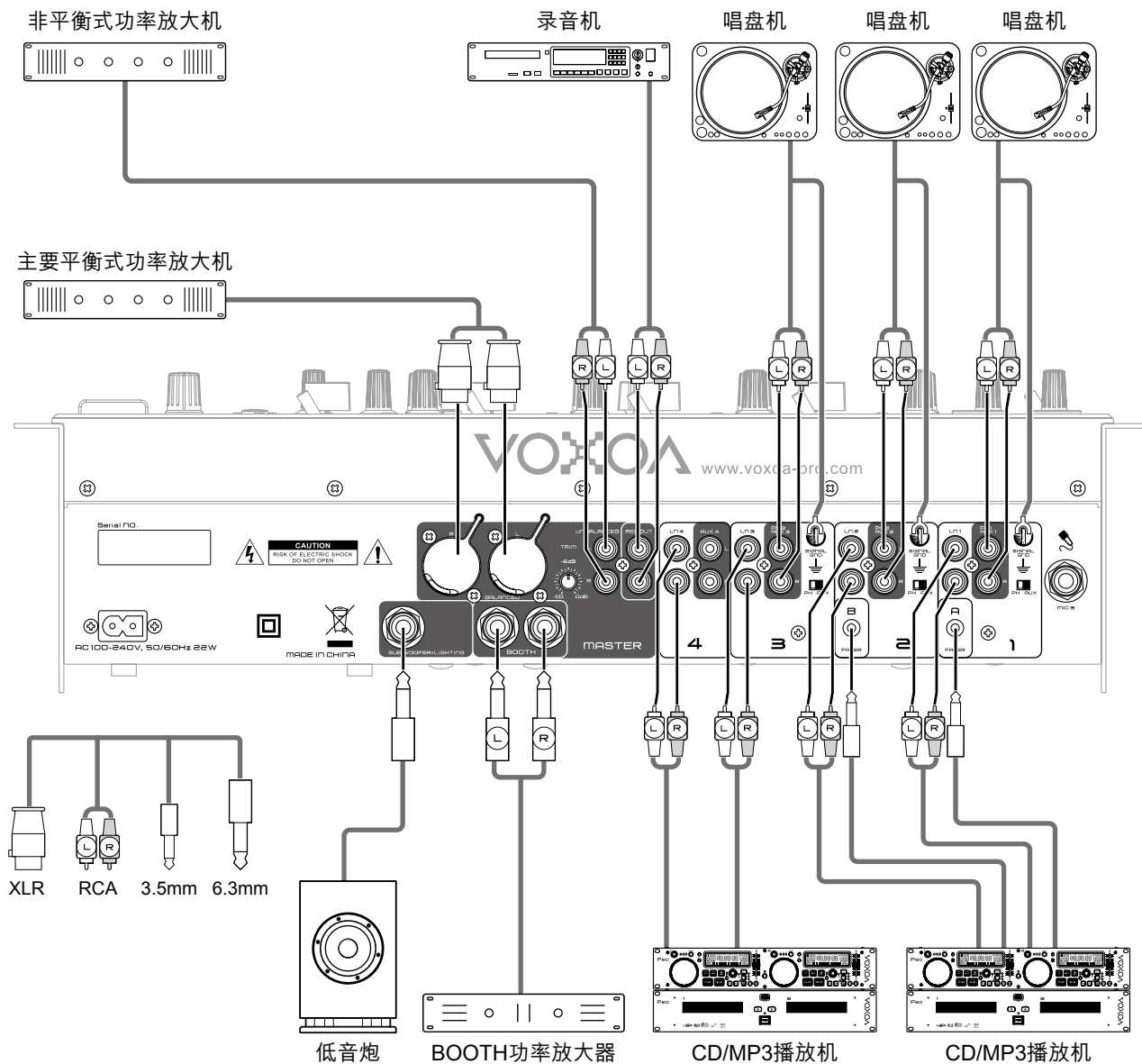

规格

1. 总体规格说明

电源:

交流电源 100 - 240V, 50/60Hz

耗电量:

22 W

尺寸:

482mm (宽) X 177mm (深) X 136.8mm (高)

重量:

4.4 公斤

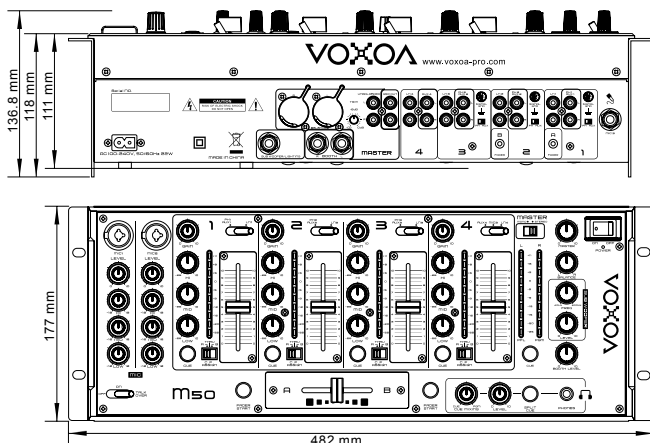

2. 输入/输出 阻抗及敏感度：(等化平坦，最大增益，CUEMIXING 置中，负载100K OHM)

• 输入阻抗及等级:

线性

20K OHM /-14dBV +/-0.1dB (200mV)

辅助插口

47K OHM /-14dBV +/-0.1dB (200mV)

唱盘插口

47K OHM /-50dBV +/-0.1dB (2mV)

麦克风 1,2,3

10K OHM /-54dBV +/-0.1dB (2mV)

• 输出阻抗及等级:

录音

1K OHM /-10dBV (316mV) +/-2dB

非平衡式主要输出

300 OHM / 0dBV (1V) +/-2dB

平衡式主要输出

600 OHM /+4dBm (+1.23V) +/-2dB @ LOAD=600 OHM

BOOTH

600 OHM /+4dBm (1.23V) +/-2dB @ LOAK=600 OHM

重低音插口

600 OHM /+2dBm (975mV) +/-2dB @ LOAK=600 OHM

耳塞口

33 OHM /+9.5dBV (3V) +/-2dB @ LOAD=32 OHM

3. 频率响应：(等化平坦，最大增益，主输出，负载100K OHM)

线性/辅助插口

25 - 20k Hz +/- 2dB

唱盘机插口

25 - 20K Hz +2/-3dB (RIAA)

麦克风

25 - 20K Hz +2/-3dB

4. 总谐波失真加噪音：(等化平坦，最大增益，w/ 20kHz LPF，主输出，负载100K OHM)

线性

低于0.05%

唱盘机插口

低于0.15%在1KHz (A-WEIGHTED)

麦克风

低于0.15%在1KHz (A-WEIGHTED)

5. 最大输入：(1 K Hz，主输出，THD=1%，等化平坦，最大增益)

线性/辅助插口	高于 +4 dBV
唱盘机插口	高于 -36 dBV
麦克风	高于 -36 dBV

6. 最大输出：(等化平坦，最大增益，THD=1%，LOAD=100K OHM)

主输出	高于+18 dBV (8.0V)
录音	高于+8dBV (2.5V)
耳塞口	高于+9.5 dBV (3.0V) 负载 32欧姆

7. 信噪比：(等化平坦，最大增益，W/20KHz LPF，A-WEIGHTED，主输出)

线性/辅助插口	高于80 dB
耳塞口	高于69 dB
麦克风	高于64 dB

8. 串音干扰：(CROSSTALK) (等化平坦，最大增益，W/20KHz LPF，A-WEIGHTED，主输出)

线性，辅助插口，唱盘机插口	高于70dB 在1K Hz 在左右声道间， 高于70dB 在1K Hz 在不同音轨间
---------------	---

9. 等化器

麦克风1及2	12 +/- 3dB, -12 +/- 3dB, AT 100 Hz 12 +/- 3dB, -12 +/- 3dB, AT 1K Hz 12 +/- 3dB, -12 +/- 3dB, AT 10K Hz
麦克风3及各通道	10 +/- 2dB, BELOW -25dB AT 70Hz 10 +/- 2dB, BELOW -25dB AT 1KHz 10 +/- 2dB, BELOW -15dB AT 13KHz

10. 通道平衡

在 3dB之内 从 0 到 -40dB

11. FADER KILL

通道推子	高于75dB 在1K Hz之下
交叉推子	高于70dB 在1K Hz之下

注意：本手册中的规格及资讯如有变更，恕不另行通知，请上网下载最新版本。

IMPORTANT SAFETY INSTRUCTIONS

1. Read these instructions.
2. Keep these instructions.
3. Heed all warnings.
4. Follow all instructions.
5. Do not use the apparatus near water.
6. Clean only with dry cloth.
7. Do not block any ventilation openings. Install in accordance with the manufacturer's instructions.
8. Do not install near any heat sources such as radiators, heat registers, stoves, or other apparatus (including amplifiers) that produce heat.
9. Do not defeat the safety purpose of the polarized or grounding-type plug. A polarized plug has two blades with one wider than the other. A grounding-type plug has two blades and a third grounding prong. The wide blade or the third prong is provided for your safety. If the provided plug does not fit into your outlet, consult an electrician for replacement of the obsolete outlet.
10. Protect the power cord from being walked on or pinched particularly at plugs, convenience receptacles, and the point where they exit from the apparatus.
11. Only use attachments/ accessories specified by the manufacturer.
12. Use only with a cart, stand, tripod, bracket or table specified by the manufacturer, or sold with the apparatus.
When a cart is used, use caution when moving the cart/apparatus combination to avoid injury from tip-over.
13. Unplug this apparatus during lighting storms or when unused for long periods of time.
14. Refer all servicing to qualified service personnel. Servicing is required when the apparatus has been damaged in any way, such as power-supply cord or plug is damaged, liquid has been spilled or objects have fallen into the apparatus, the apparatus has been exposed to rain or moisture, does not operate normally, or has been dropped.
15. When the mains plug or appliance coupler used as the disconnect device, it shall remain readily operable.
16. Please keep the unit in a good ventilation environment.



WARNING

To reduce the risk of fire or electric shock, do not expose this apparatus to rain or moisture. The apparatus shall not be exposed to dripping or splashing and that no objects filled with liquids, such as vases, shall be placed on the apparatus.



CAUTION
RISK OF ELECTRIC SHOCK
DO NOT OPEN



CAUTION : To reduce the risk of electric shock, do not remove any cover. No user-serviceable parts inside. Refer servicing to qualified service personnel only.



The lightning flash with arrowhead symbol within the equilateral triangle is intended to alert the user to the presence of un-insulated "dangerous voltage" within the product's enclosure that may be of sufficient magnitude to constitute a risk of electric shock.



The exclamation point within the equilateral triangle is intended to alert the user to the presence of important operation and maintenance (servicing) instructions in the literature accompanying this appliance.

CAUTION

To prevent electric shock, do not use this polarized plug with an extension cord, receptacle or other outlet unless the blades can be fully inserted to prevent blade exposure.

IMPORTANT SAFETY INSTRUCTIONS

17. All warnings on the appliance and in the operating instructions should be adhered to.
18. Heat - The appliance should be situated away from heat sources such as radiators, heat registers, stoves, or other appliances (including amplifiers) that produce heat.
19. Power Sources - This product should be operated only from the type of power source indicated on the rating label. If you are not sure of the type of power supply to your home, consult your product dealer or local power company. For products intended to operate from battery power, or other sources, refer the operating instructions.
20. Grounding or Polarization - This product may be equipped with a polarized alternation-current line plug (a plug having one blade wider than the other). This plug will fit into the power outlet only one way. This is a safety feature. If you are unable to insert the plug fully into the outlet, try reversing the plug. If the plug should still fail to fit, contact your electrician to replace your obsolete outlet. Do not defeat the safety purpose of the polarized plug.
21. Power-Cord Protection - Power-supply cords should be routed so that they are not likely to be walked on or pinched by items placed upon or against them, paying particular attention to the cord in correspondence of plugs, convenience receptacles, and the point where they exit from the appliance.
22. For AC line powered units - Before returning repaired unit to user, use an ohm-meter to measure from both AC plug blades to all exposed metallic parts. The resistance should be more than 100,000 ohms.
23. Non-use Periods - The power cord of the appliance should be unplugged from the outlet when left unused for a long period of time.
24. Object and Liquid Entry - Care should be taken so that objects do not fall and liquids are not spilled into the enclosure through openings.
25. Damage Requiring Service - The appliance should be serviced by qualified service personnel when: A. The power-supply cord or the plug has been damaged; or B. Objects have fallen, or liquid has been spilled into the appliance; or C. The appliance has been exposed to rain; or D. The appliance does not appear to operate normally or exhibits a marked change in performance; or E. The appliance has been dropped, or the enclosure damaged.
26. Servicing - The user should not attempt any service to the appliance beyond that that described in the operating instructions. All other servicing should be referred to qualified service personnel.
27. Lightning - For added protection for this product during a lightning storm, or when it is left unattended and unused for long periods of time, unplug it from the wall outlet and disconnect the antenna or cable system. This will prevent damage to the product due to lightning and power-line surges.
28. Replacement Parts - When replacement parts are required, be sure the service technician has used replacement parts specified by the manufacturer or have the same characteristics as the original part. Unauthorized substitutions may result in fire, electric shock, or other hazards.
29. Safety Check - Upon completion of any service or repairs to this product, ask the service technician to perform safety checks to determine that the product is in proper operating condition.

MAIN FEATURES

- 19" 4U Rack-mountable 4-channel mixer
- Input: Line x4 (RCA), Aux x4 (RCA), Phono x3 (RCA), MIC x3 (XLR/1/4 Inch Combo x 2, 6.3mm x1)
- Output: XLR Balanced x1, Unbalanced (RCA) x1, Record (RCA) x1, Booth(6.3mm) x1, Sub woofer(6.3mm) x1, Fader Start Control Out x 2 (3.5mm)
- Three-band EQ with Full output kill for each channel
- All Channel assignable to crossfader
- Independent Channel Level Meters
- 45mm VCA replaceable Crossfader
- Fully assignable crossfader with fader start function
- Fader Start compatible with VOXOA CD/MP3 Player
- Split Cue headphone monitor with PFL metering
- Master Out Stereo/Mono Switch
- Sub woofer Output with Frequency Adjust
- Booth out with level adjust

FRONT PANEL

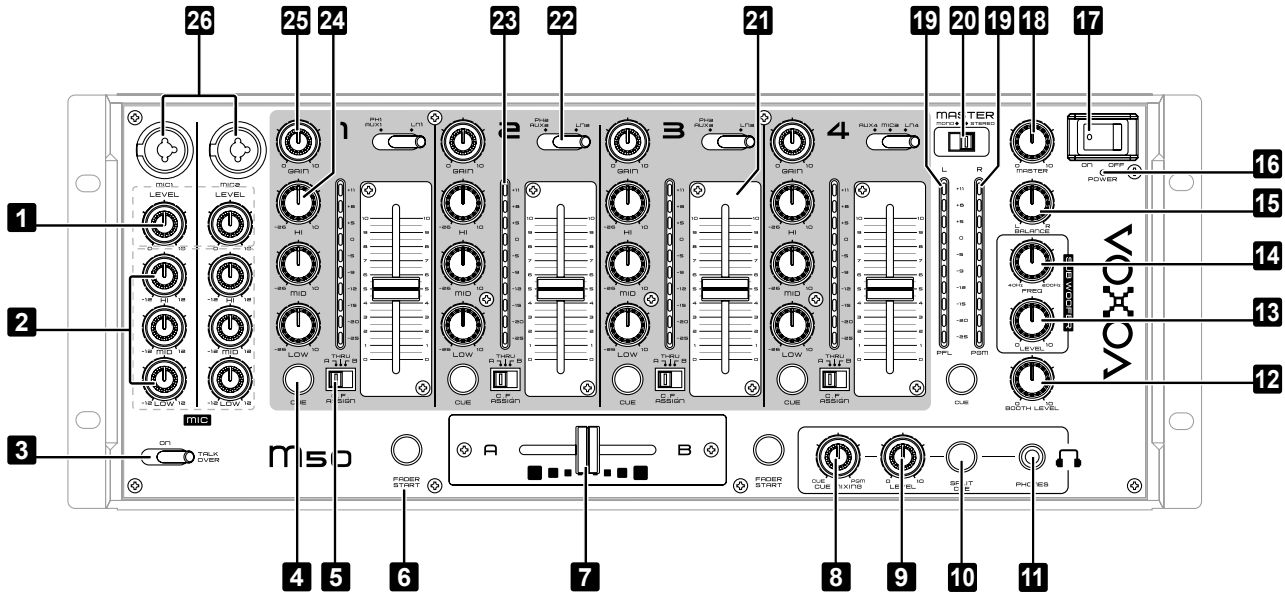

1. MIC1 & MIC2 level control

This rotary knob adjusts the output volume of MICROPHONE 1 & MICROPHONE 2.

2. MIC EQ control

This rotary knob control the frequency response of MIC1/2 separately over a range from -12dB to +12dB.

HI - This knob is used to adjust the high level of microphone from -12dB to +12dB(at 10KHz). At the center position, sound is flat.

MID - This knob is used to adjust the mid level of microphone from -12dB to +12dB(at 1KHz). At the center position, sound is flat.

LOW - This knob is used to adjust the low level of microphone from -12dB to+12dB(at 100Hz). At the center position, sound is flat.

3. MIC ON/OFF/TALKOVER switch

To set MIC on and off, when switch at the talkover position, the mic1 and 2 on, the sound level for everything other than that from the MIC will decrease to around 14dB.

4. Cue button

Pressing in any or all of CUE buttons routes the respective source to the headphone and meter cue sections. Pressing multiple buttons makes it possible to drive mixed sound from the selected sources.

5. Crossfader assign switch

Putting the switch to the corresponding position, you can select the channel signal to the left or right side of the crossfader. If you put the switch to the middle position “THRU” means the channel is not assigned to the crossfader.

6. Fader start button

This function works in conjunction with a compatible player. When used with a compatible player, you can use the crossfader to start and stop a player with the mixer’s crossfader. The button switches the FADER START feature on and off. If this function is activated, the FADER START automatically returns the player to the preset cue point.

7. Crossfader

This fader is used to blend the output signals of channels A and B together. When the fader is in the full left position (channel A), the output signal of channel A will be controlled by the master volume level. The same fundamentals will apply for channel B. Sliding the fader from one position to another will vary the output signals of channels A and B respectively. When the crossfader is set in the center position, the output signals of both the channel A and channel B will be even.

8. Cue mixing control

This function allows you to monitor the Cue level as well as the Program (main output) level in your headphones. Channels Cue Level may only be monitored if the channel CUE function is selected. To select a channel cue function press the CUE BUTTON that is directly associated with the specific channel you wish to monitor. You may use the mixing function to blend both the Cue level and the Program level together. You can vary the output level to either hear more or less of either of the two levels. Turning the Cue Mixing knob to the CUE position (left) will allow you to hear more of the Cue level. Turning the knob to the PGM position (right) will allow you to hear more of the Program level (main output). You may also use the Cue Mixing Control to hear either the Cue level or the Program level exclusively. If the knob is in the full CUE position you will only hear the cue level, if the knob is in the full PGM position you will only hear the main output. This function is especially useful when mixing without a monitor.

9. Cue level control

This rotary knob is used to adjust the headphone volume output level. Turn the knob in a clockwise direction to increase the headphone volume.

10. Split cue button

Used to select whether to split monitor MONO CUE or MONO MASTER sound on the left and right of the headphones.

- In the STEREO mode (SPILT CUE OFF), this button feeds STEREO Program (CUE MASTER) and Cue to both earcups, in the SPLIT CUE(MONO) mode, the headphone circuit provides MONO Cue to the left ear and MONO Program (MASTER) to the right.
- In the STEREO mode (SPILT CUE OFF), the meter indicates the stereo level in the LEFT and RIGHT Master Outputs. In the SPLIT CUE (MONO) mode, mono Cue level is displayed on the Left meter and mono Program (CUE MASTER) level is displayed on the right meter.
- In the SPLIT CUE (MONO) mode, the button is lit.

11. Phones jack

This jack is used to connect your headphones to the mixer allowing you to monitor the cue source. Always be sure the CUE LEVEL VOLUME is set to minimum before you put the headphones on.

12. Booth level control

This rotary knob is used to control the level of the BOOTH output terminal on the rear panel. The booth level is not affected by the master volume and master balance. The booth level is not PFL, it is essentially a second master output volume with separate output volume control.

13. Sub woofer level control

This rotary knob is used to control the level of SUB WOOFER output terminal on the rear panel.

14. Sub woofer freq control

This rotary knob is used to adjust the cut off frequency of the low pass filter from 40Hz to 200Hz. The low adjustment will affect the SUB WOOFER output.

15. Master balance control

This rotary knob is used to control the pan, adjust how much of the signal is sent to the left and right output level. For true stereo imaging, maintain the knob in the 12 o'clock position.

16. Power indicator

The indicator lights red when power is on.

17. Power switch

This is the main power ON/OFF button.

CAUTION : Before you turn the power on be sure you have made all connections to the mixer. Also be sure you amplifiers are turned off.

CAUTION : Remember to avoid damaging pops to the speakers, the mixer is turned on first and turned off last.

18. Master volume control

This rotary knob is used to control the master output level (main volume).

CAUTION : To avoid speaker damage that may be caused by excessive volume, be sure this adjustment is always set to zero before turning the unit on.

19. PFL/PGM level meter

The PFL/PGM LEVEL METER are used to monitor the STEREO master output level or the Mono output level of channel and master. In the STEREO mode, the meter indicates the stereo level in the left and right Master Outputs. In the SPLIT CUE (MONO) mode, mono Cue level is displayed on the left meter and mono Program (Cue MASTER) level is displayed on the right meter. The audio will be distorted when the signal level comes in the red zone of the LEVEL meter.

20. Master STEREO/MONO switch

Used to select either MONO or STEREO for master output.

21. Channel volume fader

These faders are used to control the output signal of any source assigned to its particular channel. However, master volume is controlled by the MASTER VOLUME CONTROL **18** .

22. Source selector switch

These switches are used to select the input source assigned to each channel. Each channel may only be assigned one input source at a time.

CAUTION : This switch must be in the “phono” position for turntable operation.

23. Channel level meter

Displays the input level after adjusted with GAIN and EQ controls. Display range: -25dB to +11dB.

24. Channel EQ section

These rotary knobs control the frequency response of the selected inputs.

HI - This knob is used to adjust the high-tone from -15dB to +10dB(at 13KHz). At the center position, sound is flat.

MID - This knob is used to adjust the mid-tone from -25dB to +10dB(at 1KHz). At the center position, sound is flat.

LOW - This knob is used to adjust the low-tone from -25dB to +10dB(at 70Hz). At the center position, sound is flat.

NOTE : Clipping may occur if adjustments are set to harsh.

25. Channel gain control

This adjustment is used to adjust the level of the selected input $-\infty$ to 14dB.

26. Microphone jack

This combo jack will accept a standard 1/4" plug or XLR 3-pin balanced male plug. The volume output level for microphone will be controlled by its own respective MIC LEVEL CONTROL KNOB **1** .

PART NAMES AND FUNCTIONS

REAR PANEL

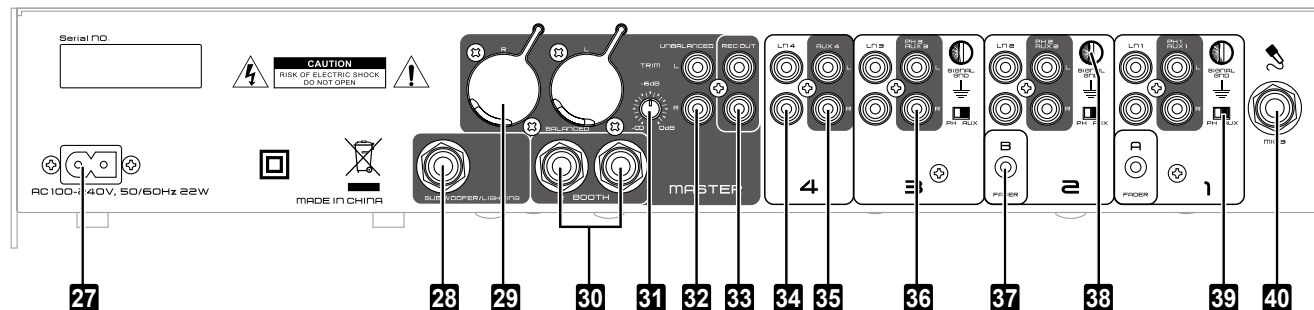

27. AC Connection

This connector is used to supply main power to the unit via the include detachable power cord. Use only the supplied power cord.

CAUTION : Be sure to only connect this unit to a power outlet that matches the printed power label on the unit. This cord is designed to fit in one direction only.

WARNING : Do not attempt to force a cord if it does not fit and be sure the cord is being inserted properly.

28. SUB WOOFER / LIGHTING output jack

This 1/4" jack provide a mono line level output of Main out. The signal is affected by the SUB WOOFER LEVEL CONTROL. **13** Connect this jack to the SUB WOOFER /LIGHTING input jack on an amplifier.

29. Balanced XLR master output jacks

The Master Output includes a pair of XLR Balanced jacks. The 3-pin XLR jacks send a high current balanced output signal.

CAUTION : These jacks should be used when you will be driving an amp or other audio equipment with a balanced input, or whenever you will be running a signal line greater than 15 feet. Always, use these jacks whenever possible.

30. Booth output jacks

This stereo pairs of balanced 1/4" jacks provide a balanced line level output with independent front panel BOOTH LEVEL CONTROL **12** and are not affected by the MASTER LEVEL CONTROL **18** .

31. Master output trim

This knob is used to decrease the master output to protect connected amplifiers and speakers from excessive input.

32. RCA master output

The RCA jacks send a low current unbalanced output signal. These jacks should only be used for shorter cable runs to signal processors or looping to another mixer.

CAUTION : For cable runs greater than 15 feet use the XLR BALANCED JACKS **29** .

33. REC output

This is a low current unbalanced output source designed for various tape and CD recorders. The Record Out (REC OUT) level is dictated by the CHANNEL VOLUME FADER **21** and the CHANNEL GAIN CONTROL **25**, it is not influenced by the MASTER VOLUME CONTROL **18**.

34. Line input jacks

DO NOT CONNECT TURNTABLES TO THESE JACKS! These Jacks are used for line level inputs. Connect CD players or Tape Decks to line level inputs. Input volume will be controlled by the CHANNEL VOLUME FADER **21**. The channel SOURCE SELECTOR SWITCH **22** must be in the "Line" position, to monitor any source connected to these jacks.

35. AUX input jacks

CD players, Tape Decks and other line level instruments may only be connected to these jacks. The red colored RCA jack represents the right channel input and the white represents the left channel input. Input volume will be controlled by the CHANNEL VOLUME FADER **21**. The channel SOURCE SELECTOR SWITCH **22** must be in the "Aux" position, to monitor any source connected to these jacks.

36. PH/AUX input jacks

The type of input must directly reflect the selected mode of the LINE LEVEL SELECTOR SWITCH **39**. Turntables equipped with MM pickup cartridge (All DJ turntable use MM pickup cartridges) may be connected to these jacks as long as the LINE LEVEL SELECTOR SWITCH **39** is in the "PHONO" position. CD players, Tape Decks and other line level instruments may only be connected to these jacks as long as the LINE LEVEL SELECTOR SWITCH **39** is in the "AUX" position. Input volume will be controlled by the CHANNEL VOLUME FADER **21**.

WARNING : Never connect line level instruments (CD players, tape decks, etc.) to these jacks when the LINE LEVEL SELECTOR SWITCH **39** is in the "PHONO" position. THIS MAY SERIOUSLY DAMAGE YOUR MIXER!

37. Fader start control jacks

This jack is used to control the "FADER START" function between the mixer and a compatible Player. Using the mini plug included with your player, connect from the player controller out jack to this jack. CH-A "FADER START" functionality will be controlled by the left side (A) of the CROSSFADER. CH-B "FADER START" functionality will be controlled by the right side (B) of the CROSSFADER. For more information on "FADER START" functionality refer to the user manual included with your player. Be sure to only use the mono tip mini plug included with your player to avoid damage to the mixer and/or the player.

38. GND (GROUND TERMINAL)

Be sure to connect turntable ground leads to either or both of the two available ground terminals. This will reduce the humming and popping noises associated with magnetic phono cartridges.

39. Channel line level selector switches

These switches are used to change the voltage line levels of the respected Phono / Aux RCA inputs jacks.

CAUTION : When connecting turntables with magnetic cartridges to these jacks be sure the corresponding switch is in the "PHONO" position, and when using line level input devices be sure the switch is in the "AUX" position.

CAUTION : Always be sure main power **17** is shut off before change the position of the Line Level Selector Switch.

40. MIC 3 jack

This jack is used to connect a microphone to the mixer. Connect you microphone via 1/4 inch jack.

1. Make certain AC power is off while making connections.
2. Quality cables make a big difference in fidelity and punch. Use high-quality, audio cables.
3. Do not use excessively long cables. Be sure plugs and jacks are securely fastened. Loose connections cause hum, noise, or intermittence that could damage your speakers.
4. Connect all stereo input sources. Then connect any effects into the stereo Effect, if used. Connect your Microphone(s) and monitor headphones. Make sure all faders are at “zero” and the unit is off. Take care to connect only one cable at a time. Pay attention to L and R position of jacks, on both the VOXOA M50 and outboard gear.
5. Connect the stereo outputs to the power amplifier(s) and/or tape deck(s) and/or MD recorder(s) and/or CD recorder(s).

CAUTION : Always switch on your audio input sources such as CD players first, then your mixer, and finally any amplifiers. When turning off, always reverse this operation by turning off amplifiers, then your mixer, and then input units.

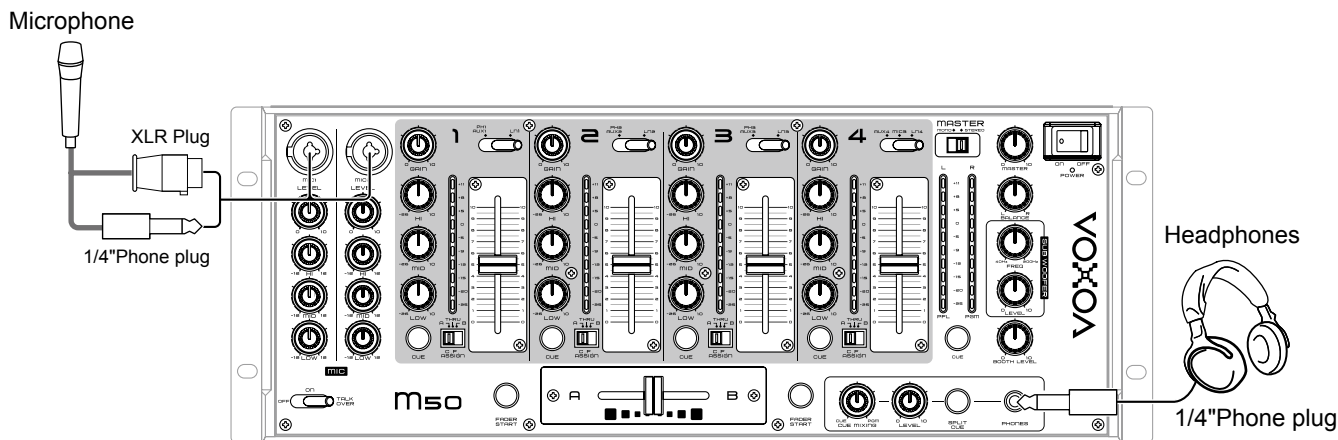

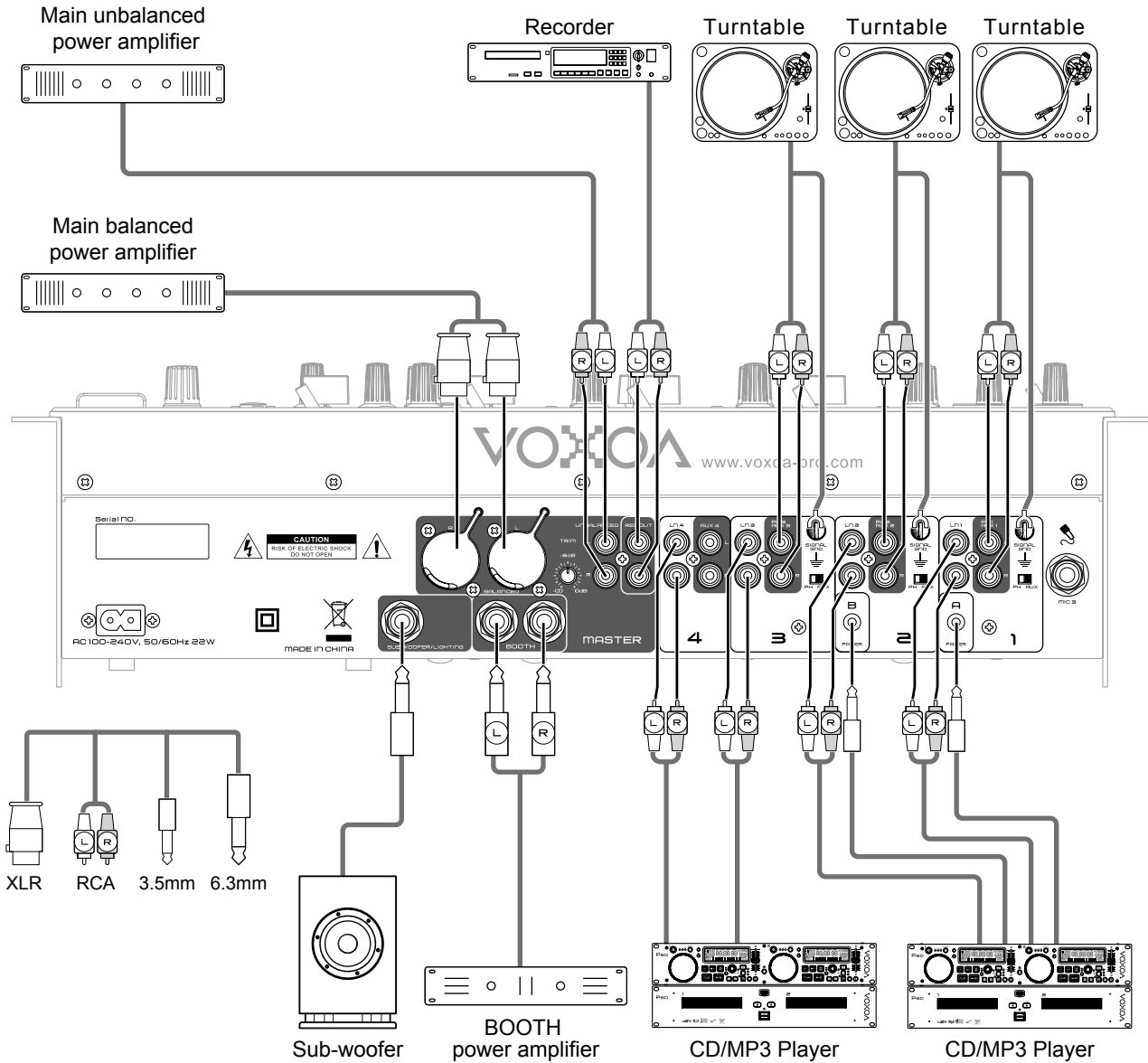

SPECIFICATIONS

1. GENERAL SECTION

POWER SOURCE:

AC100 - 240V, 50/60Hz

POWER CONSUMPTION:

22 WATTS

DIMENSIONS:

482mm (W) X 177mm (D) X 136.8mm (H)

WEIGHT:

4.4kg

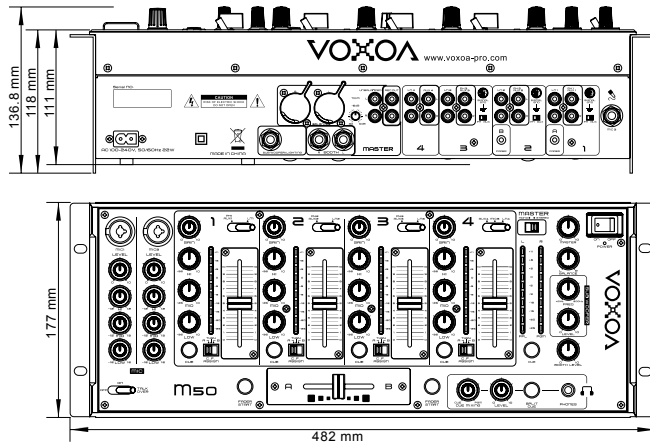

2. INPUT/OUTPUT IMPEDANCE & SENSITIVITY : (EQ FLAT, MAXIMUM GAIN, CUEMIXING CENTER, LOAD=100K OHM)

• INPUT IMPEDANCE AND REFERENCE LEVEL:

LINE	20K OHM /-14dBV +/-0.1dB (200mV)
AUX	47K OHM /-14dBV +/-0.1dB (200mV)
PHONO	47K OHM /-50dBV +/-0.1dB (2mV)
MIC1,2,3	10K OHM /-54dBV +/-0.1dB (2mV)

• OUTPUT IMPEDANCE AND LEVEL:

REC	1K OHM /-10dBV (316mV) +/-2dB
MASTER UNBAL.	300 OHM / 0dBV (1V) +/-2dB
MASTER BAL.	600 OHM /+4dBm (+1.23V) +/-2dB @ LOAD=600 OHM
BOOTH	600 OHM /+4dBm (1.23V) +/-2dB @ LOAK=600 OHM
SUB WOOFER	600 OHM /+2dBm (975mV) +/-2dB @ LOAK=600 OHM
PHONES	33 OHM /+9.5dBV (3V) +/-2dB @ LOAD=32 OHM

3. FREQUENCY RESPONSE : (EQ FLAT, MAXIMUM GAIN, MASTER OUTPUT, LOAD=100K OHM)

LINE, AUX	
PHONO	25 - 20K Hz +/-2dB
MIC	25 - 20K Hz +2/-3dB (RIAA)
	25 - 20K Hz +2/-3dB

SPECIFICATIONS

4. THD + N : (EQ FLAT, MAXIMUM GAIN, w/ 20kHz LPF, MASTER OUTPUT, LOAD=100K OHM)

LINE, AUX	LESS THAN 0.05%
PHONO	LESS THAN 0.15% @ 1KHz (A-WEIGHTED)
MIC	LESS THAN 0.15% @ 1KHz (A-WEIGHTED)

5. MAXIMUM INPUT : (1 K Hz, MASTER OUTPUT, THD=1%, EQ FLAT, MAXIMUM GAIN)

LINE, AUX	MORE THAN +4 dBV
PHONO	MORE THAN -36 dBV
MIC	MORE THAN -36 dBV

6. MAXIMUM OUTPUT : (EQ FLAT, MAXIMUM GAIN, THD=1%, LOAD=100K OHM)

MASTER	MORE THAN +18 dBV (8.0V)
REC	MORE THAN +8dBV (2.5V)
PHONES	MORE THAN +9.5 dBV (3.0V) @ LOAD=32 OHM

7. S/N RATIO : (MAXIMUM GAIN, EQ FLAT, W/20KHz LPF, A-WEIGHTED, MASTER OUTPUT)

LINE, AUX	MORE THAN 80 dB
PHONO	MORE THAN 69 dB
MIC	MORE THAN 64 dB

8. CROSSTALK : (MAXIMUM GAIN, EQ FLAT, W/20KHz LPF, A-WEIGHTED, MASTER OUTPUT)

LINE, AUX, PHONO	MORE THAN 70dB @ 1K Hz BETWEEN L AND R CHANNEL
	MORE THAN 70dB @1KHz BETWEEN CHANNELS

9. EQ

MIC1/2	12 +/- 3dB, -12 +/- 3dB, AT 100 Hz
	12 +/- 3dB, -12 +/- 3dB, AT 1K Hz
	12 +/- 3dB, -12 +/- 3dB, AT 10K Hz
MIC3/CHANNEL	10 +/- 2dB, BELOW -25dB AT 70Hz
	10 +/-2dB, BELOW -25dB AT 1KHz
	10 +/-2dB, BELOW -15dB AT 13KHz

10. CHANNEL BALANCE

Within 3dB FROM 0 TO -40dB

11. FADER KILL

MORE THAN 75dB AT 1K Hz FOR CHANNEL FADER
MORE THAN 70dB AT 1K Hz FOR CROSS FADER

NOTES : Specifications and improvements in the design of this unit and this manual are subject to change without any prior written notice.

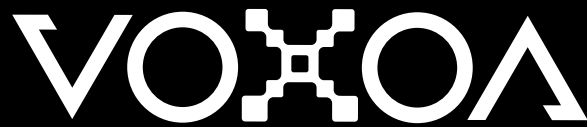

www.voxoa-pro.com