



Zebra 105SL™ Printer



Zebra 105SL™

User Guide

Customer order # 11342L Rev. 4
Manufacturer part # 11342LB Rev. 7



Proprietary Statement

This manual contains proprietary information of Zebra Technologies. It is intended solely for the information and use of parties operating and maintaining the equipment described herein. Such proprietary information may not be used, reproduced, or disclosed to any other parties for any other purpose without the expressed written permission of Zebra Technologies.

Product Improvements

Continuous improvement of products is a policy of Zebra Technologies. All specifications and signs are subject to change without notice.

FCC Compliance Statement

NOTE: This equipment has been tested and found to comply with the limits for a Class B digital device, pursuant to Part 15 of the FCC Rules. These limits are designed to provide reasonable protection against harmful interference in a residential installation. This equipment generates, uses, and can radiate radio frequency energy and, if not installed and used in accordance with the instructions, may cause harmful interference to radio communications. However, there is no guarantee that the interference will not occur in a particular installation. If this equipment does cause harmful interference to radio or television reception, which can be determined by turning the equipment off and on, the user is encouraged to try to correct the interference by one or more of the following measures:

- Reorient or relocate the receiving antenna.
- Increase the separation between the equipment and the receiver.
- Connect the equipment into an outlet on a circuit different than that to which the receiver is connected.
- Consult the dealer or an experienced Radio/TV technician for help.

NOTE: This unit was tested with shielded cables on the peripheral devices. Shielded cables must be used with the unit to ensure compliance.

“The user is cautioned that any changes or modifications not expressly approved by Zebra Technologies could void the user’s authority to operate the equipment.”

Canadian DOC Compliance Statement

This digital apparatus does not exceed the Class A limits for radio noise emissions from digital apparatus as set out in the radio interference regulations of the Canadian Department of Communications.

CE Compliance

If the accompanying printer displays the CE mark, it also meets EMC directive 89/336/EEC, with amendments effective at the time of manufacture.

Liability Disclaimer

Zebra Technologies takes steps to assure that its published Engineering Specifications and Manuals are correct; however, errors do occur. Zebra Technologies reserves the right to correct any such errors and disclaims liability resulting therefrom.

No Liability for Consequential Damage

In no event shall Zebra Technologies or anyone else involved in the creation, production, or delivery of the accompanying product (including hardware and software) be liable for any damages whatsoever (including, without limitation, damages for loss of business profits, business interruption, loss of business information, or other pecuniary loss) arising out of the use of or the results of use of or inability to use such product, even if Zebra Technologies has been advised of the possibility of such damages. Because some states do not allow the exclusion or limitation of liability for consequential or incidental damages, the above limitation may not apply to you.

Copyrights

This copyrighted manual and the label printers described herein are owned by ZIH Corp. All rights are reserved. Unauthorized reproduction of this manual or the software in the label printer may result in imprisonment of up to one year and fines of up to \$10,000 (17 U.S.C.506). Copyright violators may be subject to civil liability.

All products and brand names are trademarks of their respective companies. All rights reserved.

© 2003 ZIH Corp. All rights reserved.

DECLARATION OF CONFORMITY

I have determined that the Zebra printer identified as the

105SL™

manufactured by:

Zebra Technologies
333 Corporate Woods Parkway
Vernon Hills, Illinois 60061-3109 U.S.A.

has been shown to comply with the applicable technical standards of the FCC

for Home, Office, Commercial, and Industrial use

if no unauthorized change is made in the equipment,
and if the equipment is properly maintained and operated.

Chris Kueser



Table of Contents

<i>List of Figures</i>	<i>ix</i>
<i>Introduction</i>	<i>1</i>
Hello!	1
Unpacking and Inspection	2
Reporting Damage	2
Storage	2
Media and Ribbon Requirements	3
Power Cord	3
Printer Anatomy 101	4
<i>Calibrating the Printer</i>	<i>5</i>
Purpose	5
Types of Media	6
Non-Continuous Web Media	6
Non-Continuous Black Mark Media	7
Continuous Media	7
Choosing the Print Mode	8
Loading the Media	9
Positioning the Media Sensors	10
Transmissive Sensor	10
Black Mark Sensor	12
Loading the Ribbon	13
Operator Controls	14
POWER Switch	14
Front Panel	14
Configuring the Printer	15
Configuring the Software or Printer Driver	16
Media and Ribbon Calibration	17
Printing a Test Label	19

<i>Establishing Communication</i>	21
System Considerations	21
Interfaces	21
Data Specifications	21
Cabling Requirements	23
<i>Printer Basics</i>	25
Operator Controls	25
POWER Switch	25
Front Panel Display	26
Front Panel Keys	27
Front Panel Lights	28
Roll Media Loading	29
Tear-Off Mode	29
Peel-Off Mode	31
Rewind Mode	33
Cutter Mode	35
Peel-Only Mode	36
Removing the Label Liner	38
Fanfold Media Loading	39
Ribbon Loading	41
Ribbon Removal	43
<i>Configuration</i>	45
Entering Setup Mode	45
Changing Password-Protected Parameters	46
Leaving Setup Mode	47
Configuration and Calibration Sequence	48
<i>Routine Care and Adjustment</i>	65
Cleaning	65
Cleaning the Exterior	66
Cleaning the Interior	66
Cleaning the Printhead and Platen Roller	66
Cleaning the Sensors	68
Cleaning the Snap Plate	68
Cleaning the Cutter Module	70
Lubrication	70

Fuse Replacement	71
Adjustments	72
Toggle Positioning	72
Printhead Pressure Adjustment	73
Media Sensor Position Adjustment	73
<i>Troubleshooting</i>	75
LED Error Conditions and Warnings	75
Print Quality Problems	77
Wrinkled Ribbon	79
Communications	79
Printer Diagnostics	81
Power-On Self Test	81
Additional Printer Self Tests	81
<i>Specifications</i>	87
Media Handling	87
Options	87
ZPL Programming Language (ZPL II)	88
Bar Codes	88
General Specifications	89
Printing Specifications	90
Ribbon Specifications	90
Font Specifications	91
Media Specifications	92
Power Cord Specifications	93
<i>Appendix A: DB-25 Connectors</i>	95
Printer Interface Technical Information	95
RS-232/RS-422/RS-485 Serial Data Port	95
Parallel Data Port	99
<i>Appendix B: DB-9 Connectors</i>	101
Printer Interface Technical Information	101
RS-232 Serial Data Port	101
Parallel Data Port	106

Appendix C: PCMCIA..... Card 107
 PCMCIA Card Installation 107

Appendix D: Save-a-Printhead Cleaning Film ..109
 Extend the Life of Your Printhead with 109
 Save-a-Printhead Cleaning Film 109
 Recommended for all Zebra printers—especially 600 dpi printers 109

Index 115

Printer Software and Firmware License Agreement
Warranty Information

List of Figures

Figure 1. Printer Overview	4
Figure 2. Non-Continuous Web Media	6
Figure 3. Non-Continuous Black Mark Media	7
Figure 4. Continuous Media	7
Figure 5. Media Loading	9
Figure 6. Upper Media Sensor Adjustment	11
Figure 7. Lower Media Sensor Adjustment	12
Figure 8. Ribbon Loading	13
Figure 9. Front Panel	14
Figure 10. Media and Ribbon Calibration	17
Figure 11. Test Label	19
Figure 12. DB-25 Serial Interface	22
Figure 13. DB-9 Serial Interface	22
Figure 14. Parallel Interface	23
Figure 15. Front Panel	26
Figure 16. Tear-Off Mode Loading	30
Figure 17. Peel-Off Mode Loading	32
Figure 18. Rewind Mode Loading	34
Figure 19. Cutter Mode Loading	35
Figure 20. Peel-Only Mode Loading	37
Figure 21. Fanfold Media Loading—Bottom Supply	40
Figure 22. Fanfold Media Loading—Rear Supply	40
Figure 23. Ribbon Loading	42
Figure 24. Ribbon Hook Placement	42
Figure 25. Ribbon Removal	43
Figure 26. Media Sensor Profile	52
Figure 27. Head Resistance Value	60
Figure 28. Printhead and Platen Roller Cleaning	67
Figure 29. Snap Plate Removal and Cleaning	68

Figure 30. Snap Plate Reinstallation	69
Figure 31. Fuse Replacement	71
Figure 32. Toggle Adjustment	72
Figure 33. Test Label	82
Figure 34. PAUSE Key Test Label	83
Figure 35. FEED Key Test Label	84
Figure 36. Communications Test Label	85
Figure 37. Power Cord	93
Figure 38. International Safety Organization Symbols	93
Figure 39. RS-232 Connections	96
Figure 40. 9-Pin Serial Port Connections	97
Figure 41. RS-232 Cable Connections	97
Figure 42. DB-25 RS-422/RS-485 Connections	98
Figure 43. RS-422/RS-485 Connections	98
Figure 44. RS-232 Connections	102
Figure 45. RS-232 Cable Connections	103
Figure 46. DB-9 to DB-25 Connections	104
Figure 47. DB-25 Adapter Connections	105
Figure 48. PCMCIA Card Installation	108

Introduction

Hello!

Thank you for purchasing this high-quality Zebra 105SL™ printer, manufactured by the industry leader in quality, service, and value—Zebra Technologies. For over 30 years, Zebra has provided customers the highest caliber of products and support.

- This manual provides all of the information you need to operate your printer.
- The *ZPL II® Programming Reference Volumes I* (part number 5541L) and *II* (part number 45540L) show you how to create the perfect label format for your application. The guide also explains how ZBI™ extends the power of ZPL II by allowing custom programs to be written that operate within the printer, directly interfacing with, for example, bar code scanners and keyboard display devices. The guide also contains information about the enhanced operating system features of your printer. There are three ways to obtain these books: on the accessory CD-ROM (supplied with the printer), on our Web site (www.zebra.com), or by ordering printed manuals from your distributor.
- *The ZebraNet® Networking: PrintServer II™ User and Reference Guide* (part number 45537L) explains how you can quickly set up your printer on an IP network and experience ZebraLink™, our revolutionary real-time connectivity and control solution for Zebra printers (optional ZebraNet PrintServer II required).
- The maintenance manual for your printer (part number 32056L) contains the information you need to maintain your printer.

Unpacking and Inspection

Carefully unpack and inspect the printer for damage:

- Check all exterior surfaces.
- Raise the media access door and inspect the media compartment.

Save the carton and all packing material in case the printer needs to be shipped. Contact your authorized Zebra reseller for instructions.

Reporting Damage

If you discover shipping damage:

- Immediately notify the shipping company and file a report with them. *Zebra Technologies is not responsible for any damage incurred during shipment of the equipment and will not repair this damage under warranty.*
- Keep the carton and all packing material for inspection.
- Notify your authorized Zebra reseller.

Storage

If you are not placing the printer into operation immediately, repackage it using the original packing materials. The printer may be stored under the following conditions:

- Temperature: -40° to $+140^{\circ}$ F (-40° to $+60^{\circ}$ C)
- Relative humidity: 5% to 85% non-condensing



Media and Ribbon Requirements

Since print quality is affected by media and ribbon, printing speeds, and printer operating modes, it is very important to run tests for your applications.

We **strongly recommend** using Zebra Technologies-brand supplies for continuous high-quality printing. A wide range of paper, polypropylene, polyester, and vinyl stock has been specifically engineered to enhance the printing capabilities of the printer and to ensure against premature printhead wear.

- Continuous roll media, fanfold media, or card stock with optional perforations and registration holes may be used.
- Printhead life may be reduced by the abrasion of exposed paper fibers when using perforated media.
- The ribbon **must** be as wide as or wider than the media being used. If the ribbon is narrower than the media, areas of the printhead are unprotected and subject to premature wear. (When printing in direct thermal mode, ribbon is not used and should not be loaded in the printer.)

Power Cord



CAUTION: For personnel and equipment safety, always use a three-prong plug with a ground (earth) connection.



NOTE: Depending on how your printer was ordered, a power cord may or may not be included. If one is not included, or if the one included is not suitable for your requirements, refer to [“Power Cord Specifications”](#) on [page 93](#).

The power cord connector must be plugged into the mating connector on the rear of the printer. Make sure that the POWER on/off switch (located at the back of the printer) is in the “off” (O) position before connecting the power cable to an electrical outlet.

Printer Anatomy 101

Figure 1 outlines the basic components of your printer. Depending on the installed options, your printer may look slightly different.

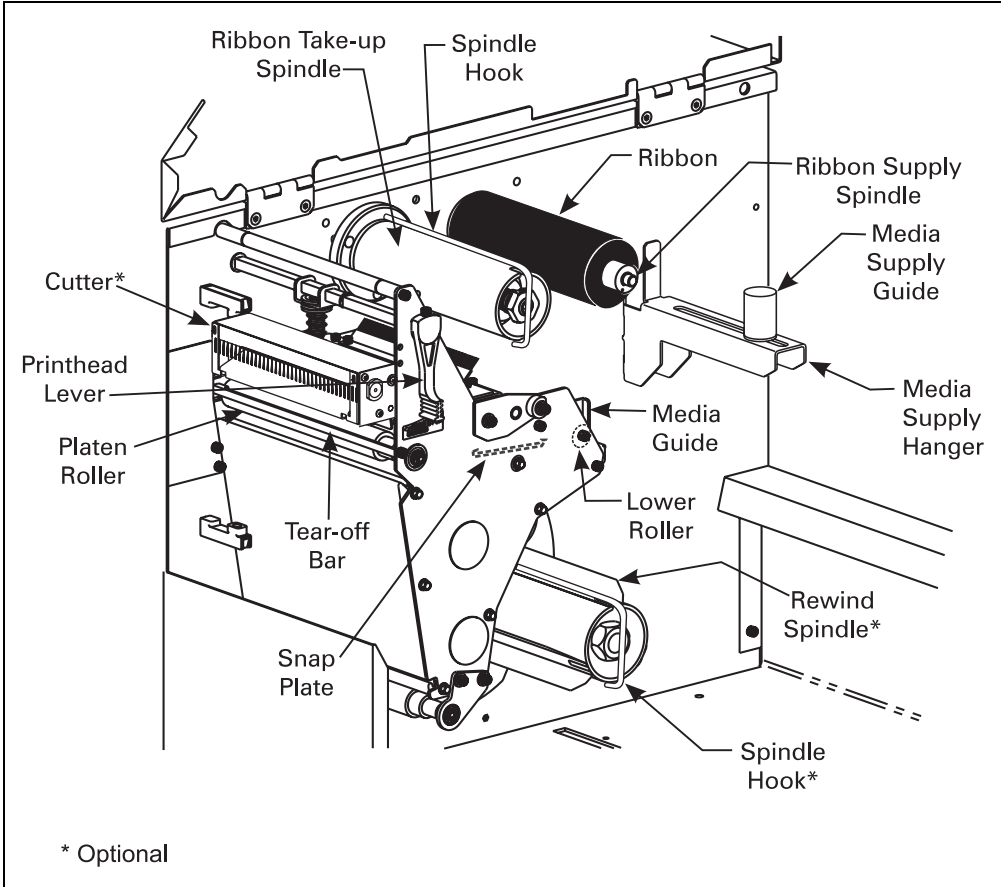

Figure 1. Printer Overview

Calibrating the Printer

Purpose

- To calibrate the printer.
- To verify that the printer is properly set up by printing a test label.



NOTE: This procedure *must* be performed when the printer is first installed or if it cannot properly detect the top of the label.

To calibrate the printer, you must perform the following procedures:

- Determine the **type of media** (labels) being used.
- Choose the **print method**.
- Position the **media sensors** (if necessary).
- **Configure the printer and software or driver** based on the label being used.
- Perform a **media and ribbon calibration**.
- Print a **test label**.

Types of Media

Non-Continuous Web Media

Non-continuous web media (refer to [Figure 2](#)) refers to individual labels that are separated by a gap, notch, or hole. When you look at the media, you can tell where one label ends and the next one begins.

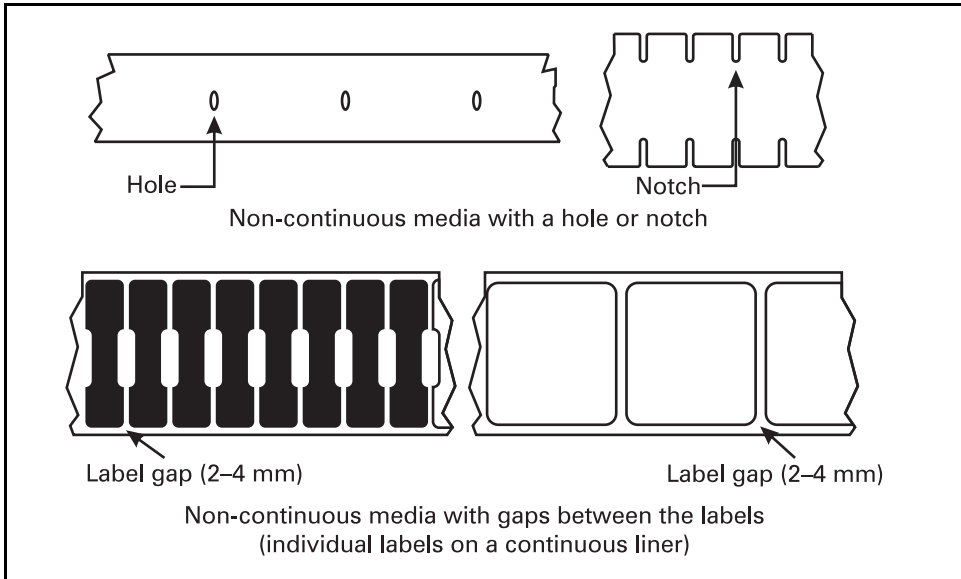

Figure 2. Non-Continuous Web Media

Non-Continuous Black Mark Media

Non-continuous black mark media has black marks printed on the back of the liner material that indicate the start and end of each label (refer to [Figure 3](#)).

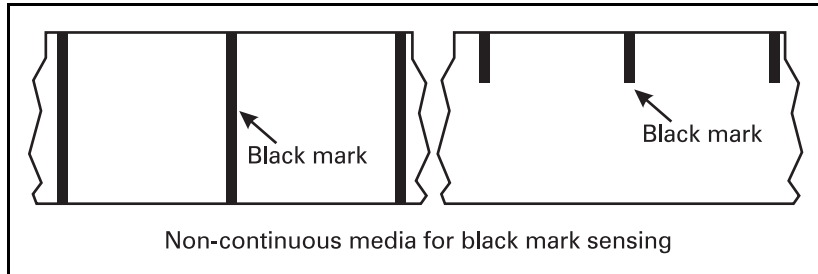

Figure 3. Non-Continuous Black Mark Media

Continuous Media

Continuous media (refer to [Figure 4](#)) is one uninterrupted roll of material that allows the image to be printed anywhere on the label.

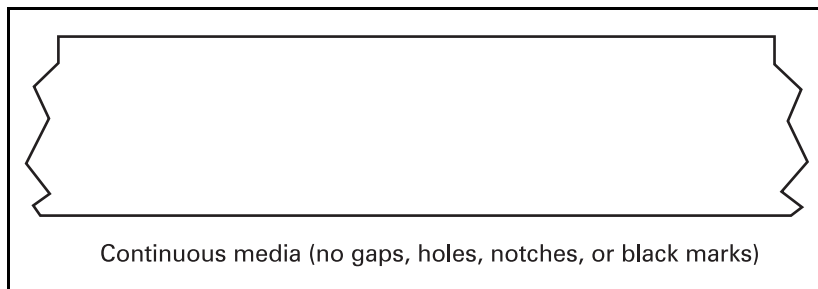

Figure 4. Continuous Media



Choosing the Print Mode

- In **Tear-Off** Mode, each label (or a strip of labels) can be torn off after it is printed.
- In **Peel-Off** Mode, backing material is peeled away from the label as it is printed. After this label is removed from the printer, the next one is printed.
- In **Cutter** Mode, the printer automatically cuts the label after a specified length has been printed.
- In **Rewind** Mode, the media and liner are rewound onto a core as the labels are printed.

Loading the Media

Figure 5 illustrates one method of media loading. For more detailed instructions, as well as information about how to load the different types of media and the various printing modes, refer to the instructions that begin on page 29.

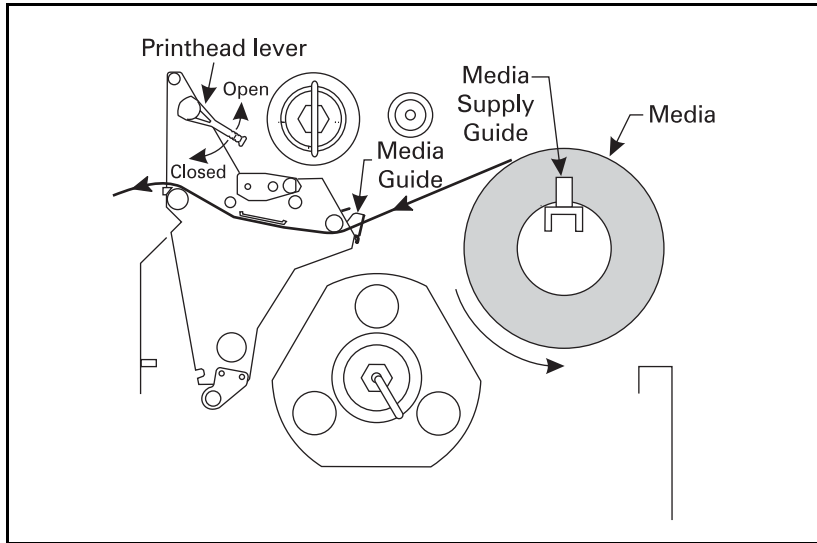

Figure 5. Media Loading

Positioning the Media Sensors

The correct positioning of the media sensors is important—it can make the difference between a perfect label and a call to Technical Support!

Transmissive Sensor

The web or gap sensor, also known as the “transmissive sensor,” detects the gap between labels.

The transmissive sensor actually consists of two sections: a light source (the lower media sensor) and a light sensor (the upper media sensor). The media passes between the two.

The upper media sensor must be positioned:

- Directly over the hole or notch, or
- Anywhere along the width of the media if there is a gap between labels.



NOTE: If you are using continuous media, position the upper media sensor over the media with the lower media sensor directly below it so that the printer can detect an out-of-paper condition.



Adjusting the Upper Media Sensor

Refer to [Figure 6](#). (For clarity, not all printer parts are shown.)

1. Remove the ribbon (if it is installed). Refer to [page 43](#) for details.
2. Locate the upper media sensor. The upper media sensor “eye” is directly below the adjustment screw head.
3. Slightly loosen the upper media sensor adjustment screw (use a Phillips-head screwdriver).
4. Using the tip of the screwdriver, slide the upper sensor along the slot to the desired position.
5. Tighten the upper media sensor adjustment screw.

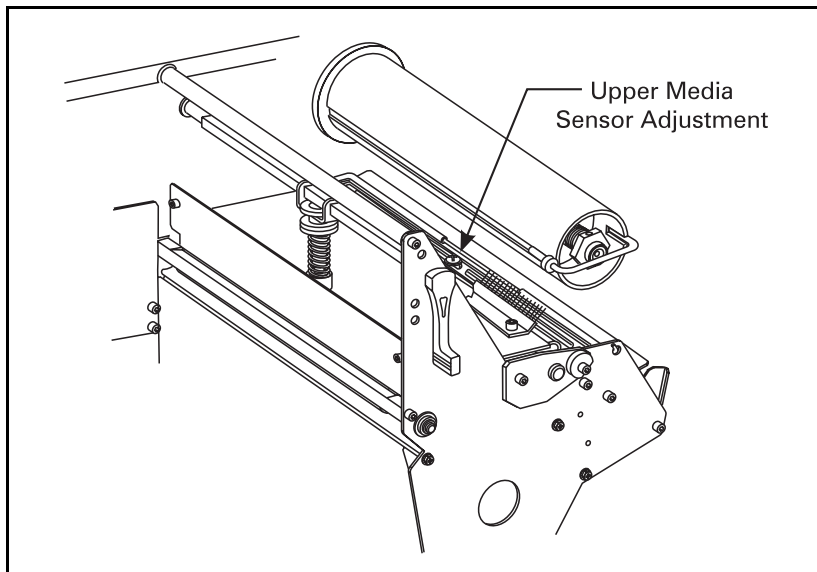

Figure 6. Upper Media Sensor Adjustment

Adjusting the Lower Media Sensor

Refer to [Figure 7](#). Position the lower media sensor by sliding it in its slot until the lower media sensor (light source) is positioned directly below the upper media sensor.

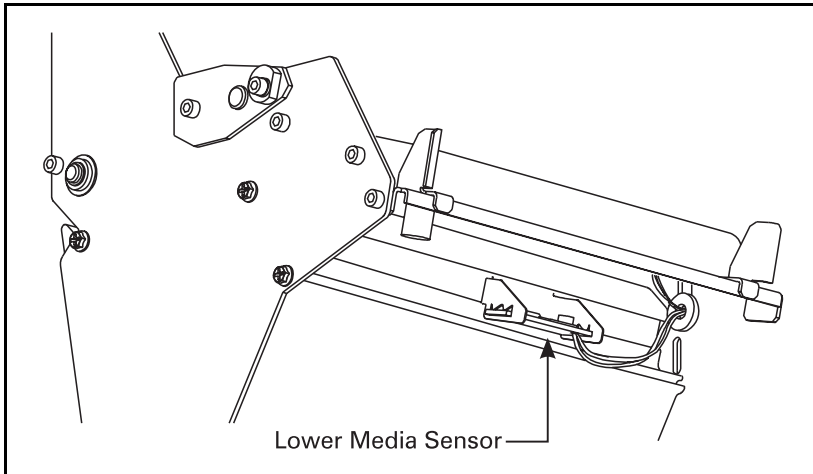

Figure 7. Lower Media Sensor Adjustment

Black Mark Sensor

The optional black mark sensor is in a fixed position and enabled via the front panel (refer to [“Configuring the Printer”](#) on [page 15](#) for details).

Loading the Ribbon

Figure 8 illustrates the ribbon path. For more detailed information, refer to the instructions that begin on [page 41](#).

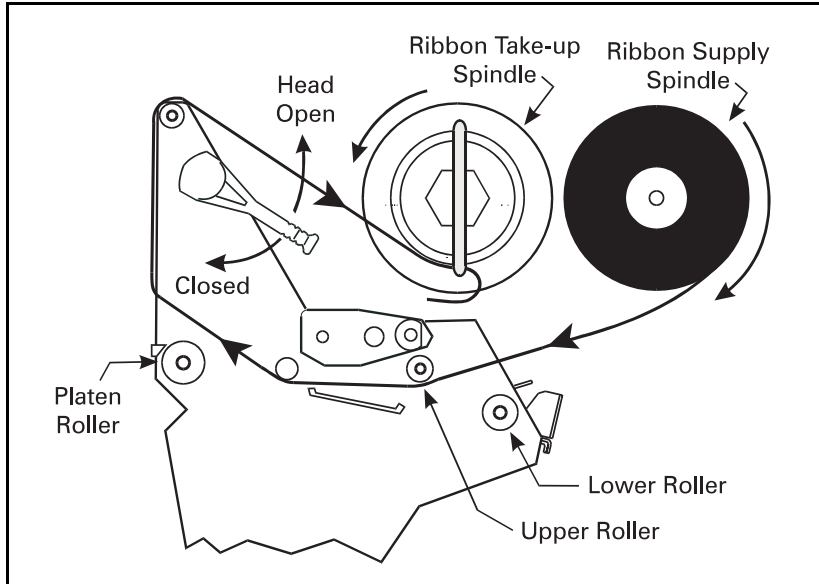

Figure 8. Ribbon Loading



Operator Controls

POWER Switch

The POWER switch is located at the back of the printer above the power cord connector. Turn on the printer (I).

Front Panel

The step-by-step instructions in this section tell you which keys to press and what appears on the liquid crystal display (LCD) during the calibration procedure.

For a more detailed explanation of the front panel keys and lights (shown in [Figure 9](#)), refer to the instructions that begin on [page 26](#).

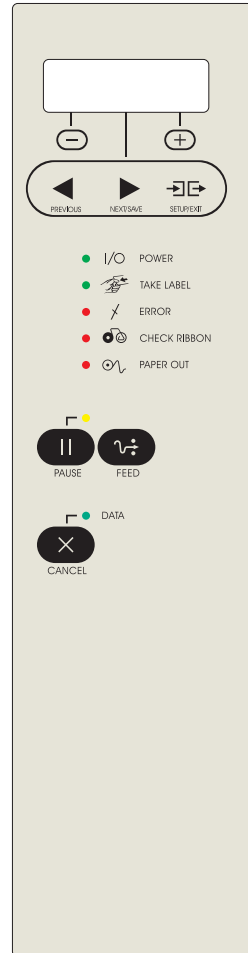

Figure 9. Front Panel

Configuring the Printer

The configuration procedure in the following table contains the information you need to get your printer up and running, *but it is not comprehensive*. Refer to [page 48](#) for more information.

- Enter Setup Mode by pressing **SETUP/EXIT** at the “PRINTER READY” display.









NOTE: You need to press **NEXT/SAVE** more than once to advance to or skip some of the displays.



- To increase the value, answer “yes,” indicate “on,” or move to the next selection, use the (+) key.
- To decrease the value, answer “no,” indicate “off,” or return to the previous selection, use the (–) key.



NOTE: When changing parameters, an asterisk (*) in the upper left-hand corner of the LCD indicates that you have changed this setting from the one that is stored currently in memory.

Press	LCD Shows	Action/Explanation
—	PRINTER READY	Normal printer operation.
 SETUP/EXIT	DARKNESS	Press the (+) or (–) keys to increase or decrease the print darkness setting. (You may need to change this setting when you print your label.)
 NEXT/SAVE	PRINT MODE	Press the (+) or (–) keys to select Tear-Off, Peel-Off, Cutter, or Rewind Mode.
 NEXT/SAVE	MEDIA TYPE	Press the (+) or (–) keys to select continuous or non-continuous media type. (If you choose continuous media, you must also include a label length instruction in your label format.)
 NEXT/SAVE	SENSOR TYPE	Press the (+) or (–) keys to select transmissive or black mark sensing mode. Unless your media has black marks on the back, leave your printer at the default setting (web).
 NEXT/SAVE	PRINT METHOD	Press the (+) or (–) keys to select thermal transfer (if you are using ribbon) or direct thermal (no ribbon).
 NEXT/SAVE	MAXIMUM LENGTH	Press the (+) or (–) keys to set the value that is closest to, but not less than, the length of the label you are using.
 NEXT/SAVE	SAVE CHANGES	Press the (+) or (–) keys to select: PERMANENT—keeps changes saved to memory after the power is turned off. Press NEXT/SAVE to accept the selection.
—	PRINTER READY	You have exited Setup Mode and are ready to calibrate the printer.

Configuring the Software or Printer Driver

Many printer settings may also be controlled by your printer’s driver or label preparation software, which may override any settings you have made manually through the front panel. Please refer to the driver or software documentation for more information.



Media and Ribbon Calibration

Initially, you may want to try autocalibrating the printer rather than proceeding with the full calibration procedure described below. To autocalibrate the printer:

1. Load the media and ribbon.
2. Close the printhead. The printer autocalibrates.

If the media fails to load or an error occurs, then perform the steps listed below.



NOTE: All steps *must* be performed in the following procedure, even if only one sensor needs to be adjusted.

1. Press **SETUP/EXIT**.
2. Press **NEXT/SAVE** until “MEDIA AND RIBBON CALIBRATE” displays.
3. Press the (+) key to start the calibration sequence. “LOAD BACKING CANCEL CONTINUE” displays.
4. Open the printhead. Remove approximately 8 in. (200 mm) of labels from the media roll, enough so that only the liner is threaded between the media sensors when the media is loaded (refer to [Figure 10](#)).

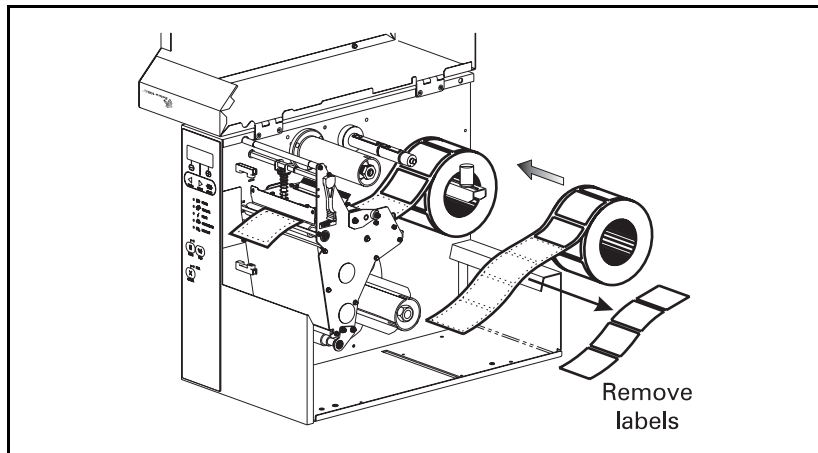

Figure 10. Media and Ribbon Calibration



5. Press the (+) key. The LCD shows “REMOVE RIBBON CANCEL CONTINUE.”
6. Slide the ribbon as far from the printer frame as possible.
7. Close the printhead, trapping the ribbon in this position.
8. Press the (+) key. The LCD shows “CALIBRATING PLEASE WAIT.”
9. When this part of the calibration process is completed, the LCD reads “RELOAD ALL CONTINUE.”
10. Open the printhead. Pull the liner until a label is positioned between the media sensors.
11. Return the ribbon to its proper position.
12. Close the printhead. Press the (+) key to perform the next part of the calibration sequence. “MEDIA AND RIBBON CALIBRATE” displays. The printer is calibrated when the media stops feeding.
13. Press **SETUP/EXIT** to leave Setup Mode. Choose “permanent” when **SAVE CHANGES** displays.
14. Press **NEXT/SAVE** to save the changes.



Printing a Test Label

To print a test label:

1. Turn off the printer (O).
2. Press and hold **CANCEL** while turning on the printer.

A configuration label prints showing the printer's currently stored parameters (similar to the one shown in [Figure 11](#)).

If you encounter any problems while you are configuring or calibrating the printer or printing a test label, refer to “[LED Error Conditions and Warnings](#)” beginning on [page 75](#).

Otherwise, refer to “[Establishing Communication](#)” beginning on [page 21](#) to set up the communication parameters.

PRINTER CONFIGURATION	
Zebra Technologies ZTC 105SL-200dpi	
+10.....	DARKNESS
+000.....	TEAR OFF
TEAR OFF.....	PRINT MODE
CONTINUOUS.....	MEDIA TYPE
WEB.....	SENSOR TYPE
THERMAL TRANS.....	PRINT METHOD
104 0/8 MM.....	PRINT WIDTH
1200.....	LABEL LENGTH
8.0IN 202MM.....	MAXIMUM LENGTH
PARALLEL.....	PARALLEL COMM.
RS232.....	SERIAL COMM.
57600.....	BAUD
8 BITS.....	DATA BITS
NONE.....	PARITY
XON/XOFF.....	HOST HANDSHAKE
NONE.....	PROTOCOL
000.....	NETWORK ID
NORMAL MODE.....	COMMUNICATIONS
<*> 7EH.....	CONTROL PREFIX
<*> 5EH.....	FORMAT PREFIX
<*> 2CH.....	DELIMITER CHAR
ZPL II.....	ZPL MODE
CALIBRATION.....	MEDIA POWER UP
CALIBRATION.....	HEAD CLOSE
DEFAULT.....	BACKFEED
+000.....	LABEL TOP
+0000.....	LEFT POSITION
070.....	WEB S.
070.....	MEDIA S.
072.....	RIBBON S.
045.....	MARK S.
080.....	MARK MED S.
075.....	MEDIA LED
015.....	RIBBON LED
037.....	MARK LED
NONE.....	LCD ADJUST
DPSWFM.....	MODES ENABLED
832 8/MM FULL.....	MODES DISABLED
V41.11.0 <.....	FIRMWARE
V02.0.0.....	HARDWARE ID
CUSTOMIZED.....	CONFIGURATION
8192.....	RAM
NONE.....	B: MEMORY CARD
0768.....	E: ONBOARD FLASH
NONE.....	FORMAT CONVERT
005 DISPLAY.....	P31 INTERFACE
DYNAMIC.....	TWINAX/COAX ID
ALL.....	IP RESOLUTION
010.003.004.135.....	IP ADDRESS
255.255.255.000.....	SUBNET MASK
010.003.004.001.....	DEFAULT GATEWAY

FIRMWARE IN THIS PRINTER IS COPYRIGHTED

Figure 11. Test Label



Establishing Communication

System Considerations



NOTE: Depending on the date of manufacture, your Zebra 105SL printer may be equipped with either a DB-25 serial connector or a DB-9 serial connector.

Interfaces

The method of interfacing this printer to a data source depends on the communication options installed in the printer. Following are the standard interfaces for a DB-25 and a DB-9 serial interface connector:

Serial Connector	Standard Interfaces
DB-25	<ul style="list-style-type: none">• RS-232/RS-422/RS-485 serial data port• Bidirectional parallel port
DB-9	<ul style="list-style-type: none">• RS-232 serial data port• Bidirectional parallel port

The optional ZebraNet PrintServer II enables printers to be connected to 10Base-T Ethernet networks. In addition, the IBM[®] Twinax or IBM Coax option is available for those applications that require them.



NOTE: If you have the DB-9 serial interface connector, RS-422 and RS-485 serial data ports are available through an adapter. Contact your Zebra distributor for details.

Data Specifications

When communicating via an asynchronous serial data port (refer to [Figure 12](#) for a DB-25 serial interface connector and [Figure 13](#) for a DB-9 serial interface connector), the baud rate, number of data and stop bits, parity, and handshaking are user selectable. Parity applies only to data transmitted by the printer since the parity of received data is ignored.

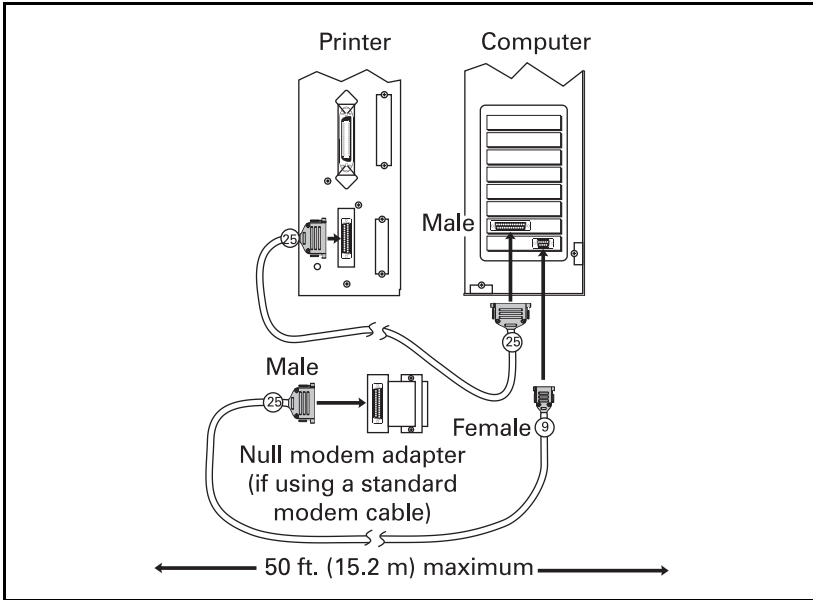

Figure 12. DB-25 Serial Interface

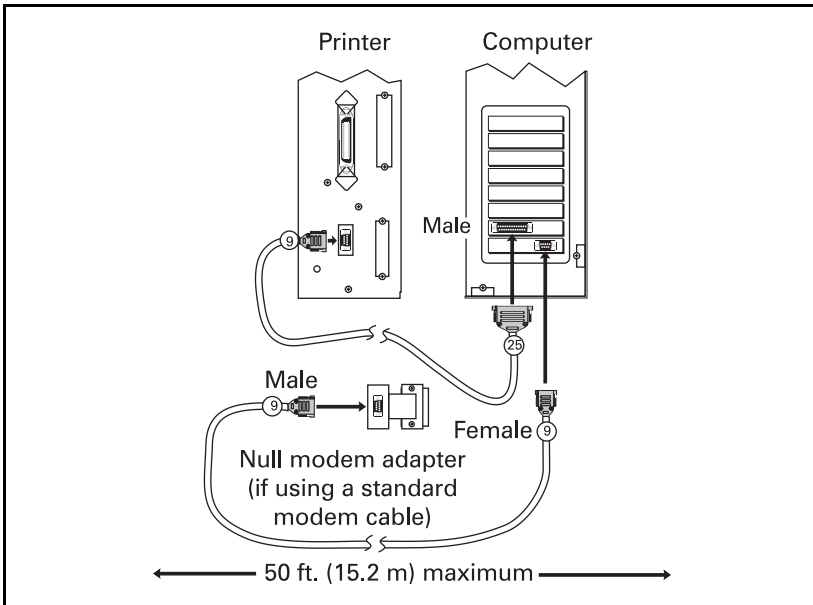

Figure 13. DB-9 Serial Interface



When communicating via the parallel port (refer to [Figure 14](#)), the previously mentioned parameters are not considered. Refer to [page 54](#) to configure the communication parameters for the printer. The values selected must be the same as those used by the host equipment connected to the printer.

For serial and parallel pinout and technical information, refer to “[Appendix A: DB-25 Connectors](#)” on [page 95](#) or “[Appendix B: DB-9 Connectors](#)” on [page 101](#).

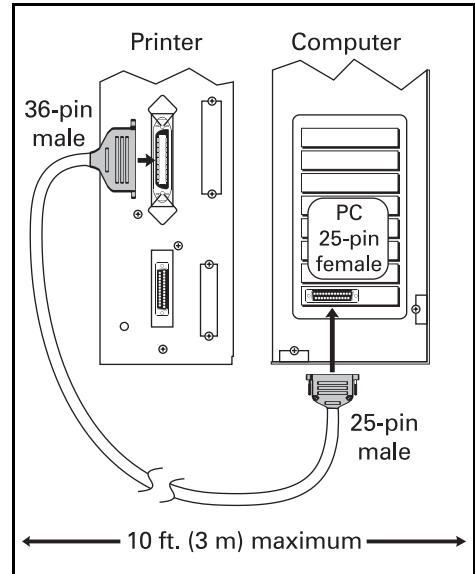

Figure 14. Parallel Interface

Cabling Requirements

Data cables must be fully shielded and fitted with metal or metallized connector shells. Shielded cables and connectors are required to prevent radiation and reception of electrical noise.

To minimize electrical noise pickup in the cable:

- Keep data cables as short as possible.
- Do not bundle the data cables tightly with the power cords.
- Do not tie the data cables to power wire conduits.



NOTE: Zebra printers comply with FCC “Rules and Regulations,” Part 15, Subpart J, for Class B Equipment, using fully shielded 6 ft. (1.8 m) data cables. Use of longer cables or unshielded cables may increase radiated emissions above the Class B limits. RS-422 and RS-485 applications should use twisted shielded pairs as recommended in the Appendix of the TIA/EIA RS-485 Specification.



Printer Basics

Operator Controls

This section discusses the functions of the controls and indicators on the printer. Become familiar with each of these functions before operating your 105SL printer.

POWER Switch

This switch is located at the back of the printer above the power cord. The POWER switch should be turned off (O) before connecting or disconnecting any cables.

External influences, such as lightning storms or noise on the power or data cables, may cause erratic printer behavior. Turning the printer's power off and then back on may re-establish proper printer operation.

Front Panel Display

The front panel display (shown in [Figure 15](#)) communicates operational status and setup modes and parameters.

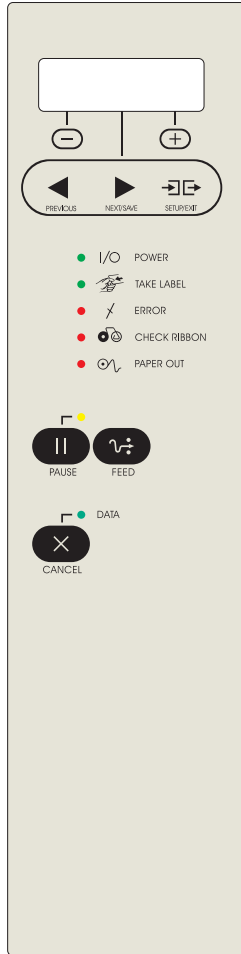









Figure 15. Front Panel









Front Panel Keys

Key	Function
	<p>Starts and stops the printing process.</p> <ul style="list-style-type: none"> • If the printer is not printing: no printing can occur. • If the printer is printing: printing stops once the current label is complete. <p>Press to remove error messages from the LCD.</p> <p>NOTE: Pause Mode can also be activated via ZPL II (<code>~PP</code>, <code>^PP</code>).</p>
	<p>Forces the printer to feed one blank label each time the key is pressed.</p> <ul style="list-style-type: none"> • Printer not printing: one blank label immediately feeds. • Printing: one blank label feeds after the current batch of labels is complete. <p>NOTE: Equivalent to the Slew to Home Position (<code>~PH</code>, <code>^PH</code>) ZPL II instruction.</p>
	<p>When in Pause Mode, this key cancels print jobs.</p> <ul style="list-style-type: none"> • Print job in queue: press once for each print job to be deleted. • Press and hold for several seconds to cancel all print jobs in the printer's memory. The DATA light turns off.
<p>NOTE: The keys below are used only when configuring the printer. Specific uses of these keys are explained in "Configuration," beginning on page 45.</p>	
	<ul style="list-style-type: none"> • Scrolls back to the previous parameter. • Press <i>and hold</i> to go backward quickly through parameter sets.
	<ul style="list-style-type: none"> • Scrolls forward to the next parameter. (Saves any changes you have made in the configuration and calibration sequence.) • Press <i>and hold</i> to advance quickly through parameter sets.
	<p>Enters and exits Setup Mode.</p>
	<p>These keys change the parameter values. They are used in different ways depending on the parameter displayed. Common uses are: to increase/decrease a value; answer "yes" or "no;" indicate "on" or "off;" scroll through several choices; input the password; or set up the printer for a firmware download.</p>
	

Front Panel Lights



NOTE: If two operating conditions occur simultaneously (for example, one that causes a light to be on constantly and one that causes the same light to flash), the light flashes.

Light	Status	Indication
POWER 	Off	The printer is off or power is not applied.
	On	The printer is on.
TAKE LABEL 	Off	Normal operation.
	Flashing	(Peel-Off Mode only.) The label is available. Printing is paused until the label is removed.
ERROR 	Off	Normal operation—no printer errors.
	Flashing	A printer error exists. Check the LCD for more information.
CHECK RIBBON 	Off	Normal operation—ribbon (if used) is properly loaded.
	On	Printing is paused, the LCD displays a warning message, and the PAUSE light is on. <ul style="list-style-type: none"> If the printer is in Direct Thermal Mode: ribbon is loaded. If the printer is in Thermal Transfer Mode: no ribbon is loaded.
PAPER OUT 	Off	Normal operation—media is properly loaded.
	On	No media is under the media sensor. Printing is paused, the LCD shows an error message, and the PAUSE light is on.
PAUSE 	Off	Normal operation.
	On	The printer has stopped all printing operations. Either PAUSE was pressed, a pause command was included in the label format, the online verifier detected an error, or a printer error was detected. Refer to the LCD for more information.
DATA 	Off	Normal operation. No data being received or processed.
	On	Data processing or printing is taking place. No data is being received.
	Flashing	The printer is receiving data from <i>or</i> sending status information to the host computer. Flashing slows when the printer cannot accept more data, but returns to normal once data is again being received.



Roll Media Loading



NOTE: A calibration must be performed with **all** loading modes during the following circumstances if the printer is set to Feed or No Motion at power up or head close:

- When media and ribbon (if used) are first installed in the printer.
- When media or ribbon is changed to a different type.

Tear-Off Mode

Refer to [Figure 16](#).

1. Open the printhead.
2. Slide the media guide and media supply guide as far from the printer frame as possible.
3. Load media as shown.
4. Slide in the media guide and media supply guide so they just touch, but do not restrict, the edge of the roll.
5. Close the printhead.

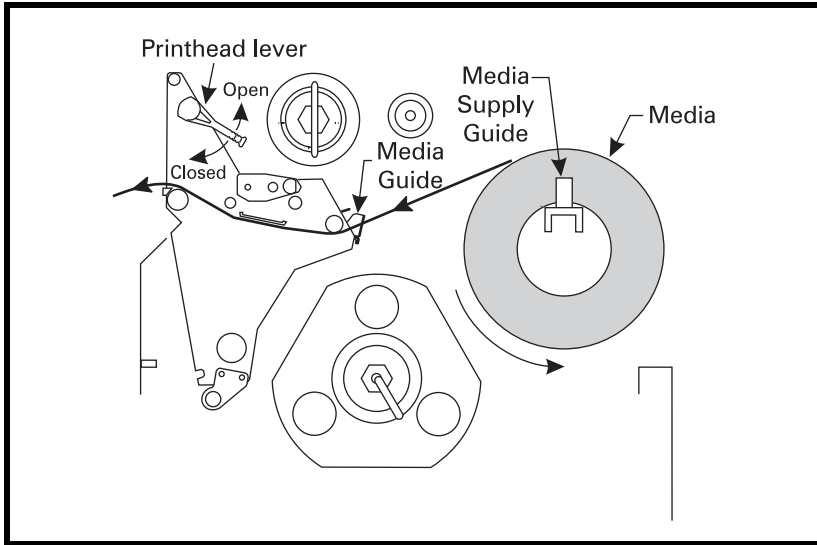

Figure 16. Tear-Off Mode Loading



Peel-Off Mode

Refer to [Figure 17](#).



NOTE: The following instructions pertain to printers with the rewind option only.

1. Remove the rewind plate from the front of the printer (if installed). Store it upside down on the two mounting screws on the inside of the front panel.
2. Open the printhead.
3. Slide the media guide and media supply guide as far from the printer frame as possible.
4. Load media as shown.
5. When loading media, allow approximately 36 in. (915 mm) of media to extend past the tear-off bar. Remove all labels from this portion to create a leader.
6. Remove the hook from the rewind spindle. If you are using a core, slide it onto the rewind spindle until it is flush against the guide plate.
7. Wind the label liner around either the 3 in. (76.2 mm) core *or* the rewind spindle and reinstall the hook.
8. Slide in the media guide and media supply guide so they just touch, but do not restrict, the edge of the roll.



NOTE: Before closing the printhead, make sure:

- the media is positioned against the inside guides.
 - the media is taut and parallel with itself and the pathway when wound onto the rewind spindle/core.
9. Close the printhead.
 10. To discard the label liner from the rewind spindle, refer to [“Removing the Label Liner”](#) on [page 38](#).

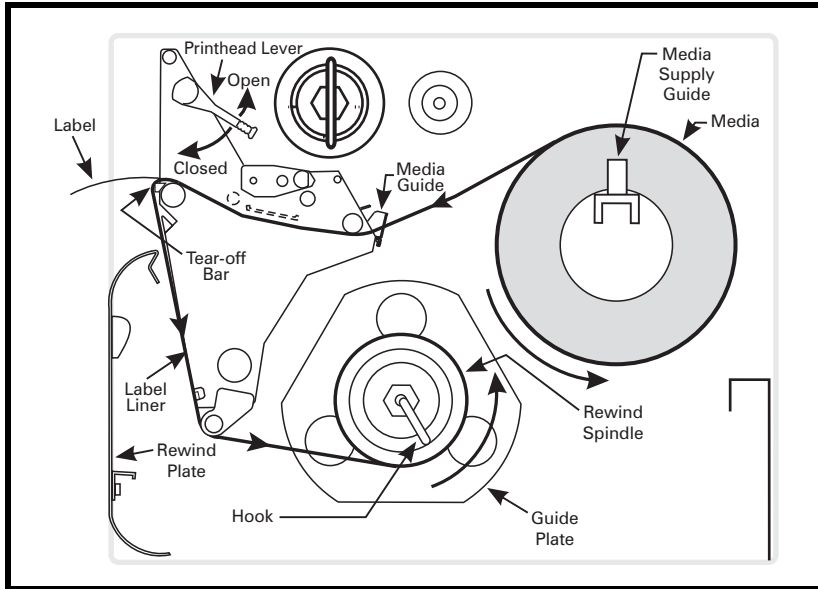

Figure 17. Peel-Off Mode Loading



Rewind Mode

Refer to [Figure 18](#).



NOTE: The following instructions pertain to printers with the rewind option only.

1. Remove the rewind plate from its storage location in front of the print mechanism inside the media compartment.
2. Invert the rewind plate so that the lip on the attached hook plate points down.
3. Insert the hook plate lip a short distance ($\frac{1}{2}$ in. or 13 mm) into the lower opening in the side plate.
4. Align the upper end of the rewind plate with the corresponding opening in the side plate. Slide in the rewind plate so that it stops against the printer's main frame.
5. Open the printhead.
6. Slide the media guide and media supply guide as far from the printer frame as possible.
7. Load media as shown.
8. When loading media, allow approximately 36 in. (915 mm) of media to extend past the printhead. Remove all labels from this portion to create a leader.
9. Remove the hook from the rewind spindle. If you are using a core, slide it onto the rewind spindle until it is flush against the guide plate.
10. Wind the label liner around either the 3 in. (76.2 mm) core *or* the rewind spindle and reinstall the hook.
11. Slide in the media guide and media supply guide so they just touch, but do not restrict, the edge of the roll.



NOTE: Before closing the printhead, make sure:

- The media is positioned against the inside guides.
- The media is taut and parallel with itself and the pathway when wound onto the rewind spindle or core.

12. Close the printhead.

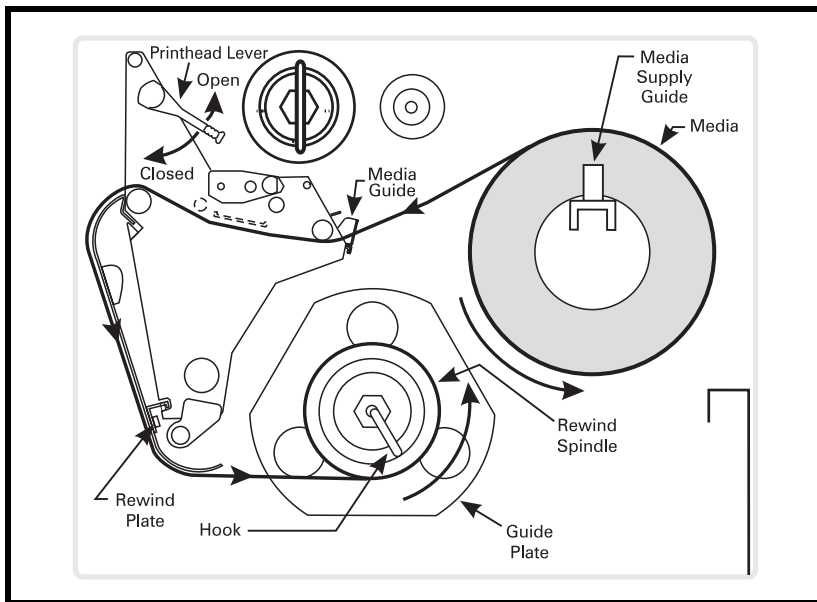

Figure 18. Rewind Mode Loading



Cutter Mode

Refer to [Figure 19](#).



NOTE: The following instructions pertain to printers with the cutter option only.

1. Open the printhead.
2. Slide the media guide and media supply guide as far from the printer frame as possible.
3. Load media as shown.
4. Slide in the media guide and media supply guide so they just touch, but do not restrict, the edge of the roll.
5. Close the printhead.
6. The printer automatically feeds out and cuts one label when the printer is turned on.

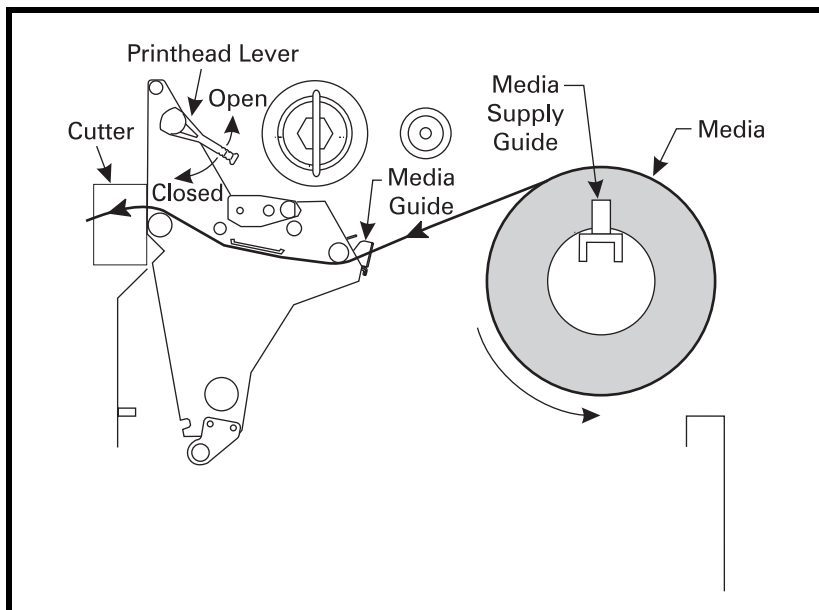

Figure 19. Cutter Mode Loading

Peel-Only Mode

Refer to [Figure 20](#).



NOTE: The following instructions pertain to printers with the peel option only.

1. Press the printhead open lever. The printhead assembly springs up.
2. Slide out the media supply guide as far from the printer frame as possible.
3. Place the roll of media on the media supply hanger and orient the media properly.
4. Slide in the media supply guide so that it just touches, but does not restrict, the edge of the roll.
5. Feed the media under the inner media guide in the print mechanism.
6. Pull approximately 36 in. (915 mm) of media through the front of the printer.
7. Ensure that the media is against the inner media guide. Slide in the outer media guide so that it just touches, but does not restrict, the edge of the media.
8. Close the printhead assembly.



NOTE: If your printer has a **peel with a rewind** option, remove the rewind plate and store it upside down on the mounting screw on the inside of the front panel **before** proceeding to step 9.

9. Remove the hook from the take-up spindle shaft.
10. Remove several labels from the media liner and then wind the liner 1–2 times around the media take-up spindle and reinstall the hook.

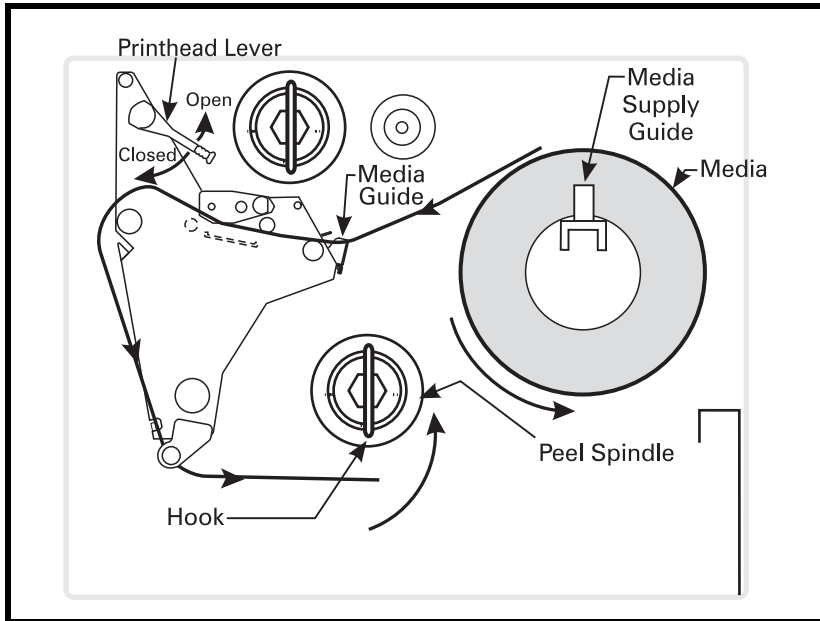

Figure 20. Peel-Only Mode Loading

Removing the Label Liner



NOTE: Since the rewind spindle holds the liner from a standard-size media roll, we recommend that you perform this procedure whenever you change the media.

To remove the liner from the rewind spindle, follow these steps (you do not need to turn off the printer for this procedure):

1. Unwind approximately 36 in. (915 mm) of liner from the rewind spindle. Cut it off at the spindle.
2. Pull out the hook. Slide the liner off of the rewind spindle and discard.
3. Wind the media around the rewind spindle once or twice and reinstall the hook. Continue winding to remove any slack in the media.



Fanfold Media Loading



NOTE: A calibration must be performed when media and ribbon (if used) are first installed in the printer, or when a different type of media or ribbon is being used.

Fanfold media feeds through either the bottom or rear access slot from outside the printer.

Refer to [Figure 21](#) and [Figure 22](#).

1. Open the printhead.
2. Slide the media guide as far from the printer frame as possible.
3. Load media as shown. If the printer is in Cutter Mode, route the media through the cutter.
4. Slide in the media guide so it just touches, but does not restrict, the edge of the roll.
5. Close the printhead.

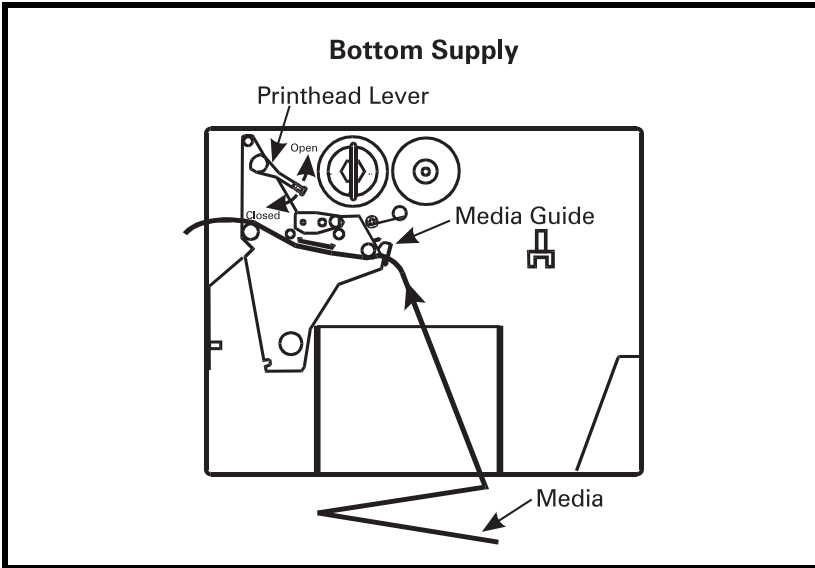

Figure 21. Fanfold Media Loading—Bottom Supply

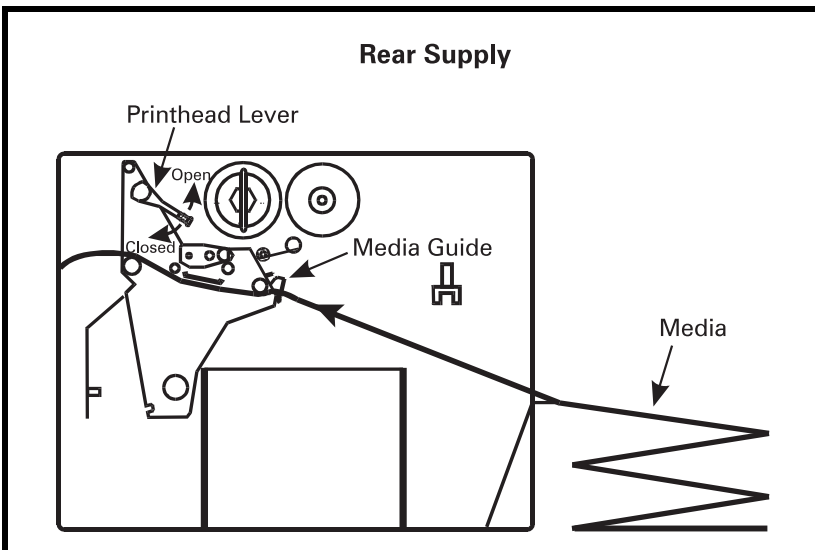

Figure 22. Fanfold Media Loading—Rear Supply



Ribbon Loading

To load ribbon, refer to [Figure 23](#) and follow the procedure below.



NOTE: Always use ribbon that is at least as wide as the media. The smooth liner of the ribbon protects the printhead from wear and premature failure due to excessive abrasion. (For direct thermal print mode, ribbon is not used and should not be loaded in the printer.)

1. Align the segments of the ribbon supply spindle.
2. Place the ribbon roll on the ribbon supply spindle.

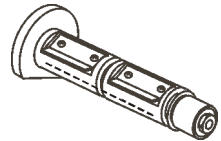

NOTE: Make sure that the core is pushed up against the stop on the ribbon supply spindle and that the ribbon is aligned squarely with its core. If this is not done, the ribbon may not cover the printhead entirely on the inside, exposing print elements to potentially damaging contact with the media

3. To make ribbon loading and unloading easier, make a leader for your ribbon roll if one is not present.
4. Tear off a strip of media (labels and liner) about 6–12 in. (150–305 mm) long from the roll. Peel off a label from this strip. Apply half of this label to the end of the strip and the other half to the end of the ribbon. This acts as a ribbon leader.

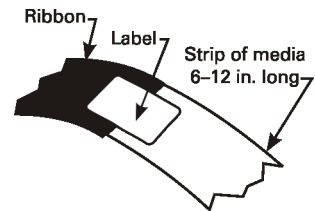

5. Open the printhead and thread the leader and attached ribbon through the print mechanism, under the upper roller, and past the platen roller as shown.
6. Before wrapping the ribbon around the ribbon take-up spindle, ensure the ribbon hook is placed correctly. The ribbon hook fits snugly in the notch (see [Figure 24](#)).

7. Place the ribbon with leader around the ribbon take-up spindle and wind counterclockwise for several turns (see [Figure 23](#)).
8. Close the printhead.

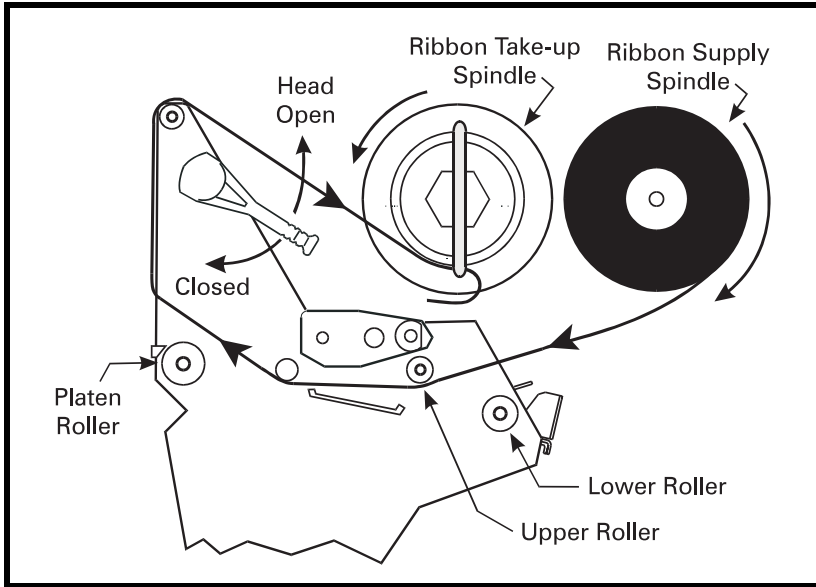

Figure 23. Ribbon Loading

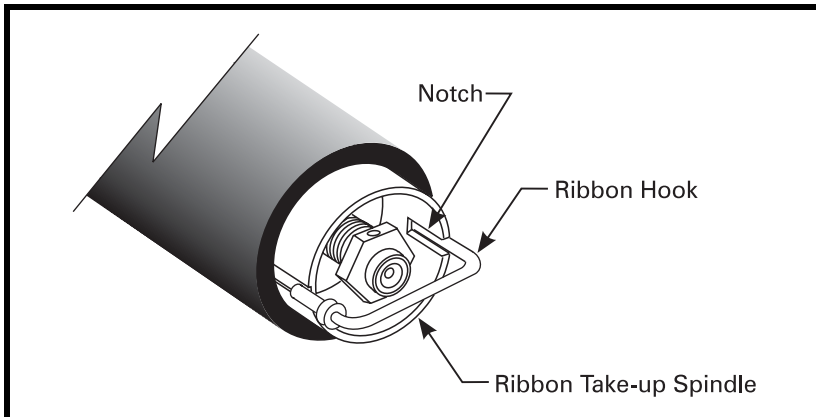

Figure 24. Ribbon Hook Placement



Ribbon Removal

Refer to [Figure 25](#).

1. If the ribbon is not exhausted, cut or break it as close to the ribbon take-up spindle as possible.
2. Push the hook either forward or backward with your thumb until it slips out of the groove (1). Slide the hook to the side (2), then rotate it back and forth several times to loosen it (3).
3. Remove the loosened hook from the spindle (4).
4. Lightly tap the top of the used ribbon to loosen it; grasp the used ribbon and remove it from the ribbon take-up spindle.
5. Remove the core from the ribbon supply spindle.
6. Follow the ribbon loading procedure on [page 41](#) to load the new ribbon.

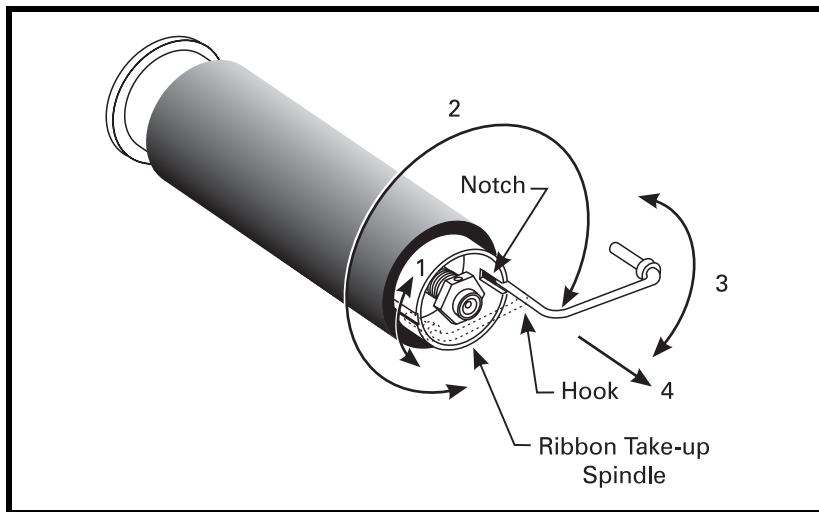

Figure 25. Ribbon Removal



Configuration

After you have installed the media and ribbon and the Power-On Self Test (POST) is complete, the LCD shows “PRINTER READY.” (If the printer fails its POST, refer to [page 81](#).) Using the front panel display and the five keys directly below it, set the printer parameters for your application.



NOTE: Printers that are operating on an IP network can be quickly configured using ZebraNet WebView (optional ZebraNet PrintServer II required). For information, refer to *PrintServer II™ Installation and Users Guide* (part number 48152L).

If it becomes necessary to restore the initial printer defaults, see “[FEED Key and PAUSE Key Self Test](#)” on [page 85](#).

Unless otherwise noted, all parameters are listed in the order they are displayed, starting with “DARKNESS.”

Entering Setup Mode

To enter Setup Mode, press **SETUP/EXIT**. Press either **NEXT/SAVE** or **PREVIOUS** to scroll to the parameter you wish to set.



NOTE: You may also press and hold **NEXT/SAVE** and **PREVIOUS** to advance quickly through the configuration parameters.

Parameters in this section are shown in the order displayed when pressing **NEXT/SAVE**. Throughout this process, press **NEXT/SAVE** to continue to the next parameter, or press **PREVIOUS** to return to the previous parameter in the cycle.

An asterisk (*) in the upper left-hand corner of the LCD indicates that the value displayed is different from the currently stored value.

Changing Password-Protected Parameters

Certain parameters are password-protected by factory default.

CAUTION: Beginners should not attempt to change password-protected parameters. This activity should be performed by trained individuals only—parameters set incorrectly could cause the printer to function unpredictably.

The first attempt to change one of these parameters (pressing either the (+) or (–) key) requires you to enter a four-digit password at the “ENTER PASSWORD” display. The (–) key changes the selected digit position; the (+) key increases the selected digit value. After entering the password, press **NEXT/SAVE**. The parameter you wish to change is displayed. If the password was entered correctly, you can now change the value.

The default password value is 1234. The password can be changed using the \wedge KP (Define Password) ZPL II instruction or through ZebraNet WebView (optional ZebraNet PrintServer II required).



NOTE: Once the password has been entered correctly, it does not have to be entered again unless you leave and re-enter Setup Mode using **SETUP/EXIT**.

You can disable the password-protection feature so that it no longer prompts you for a password by setting the password to $\emptyset\emptyset\emptyset\emptyset$ via the \wedge KP \emptyset ZPL/ZPL II command. To re-enable the password-protection feature, send the ZPL/ZPL II command \wedge KPx, where “x” can be any number, one to four digits in length, except \emptyset .

Leaving Setup Mode

You can leave Setup Mode at any time by pressing **SETUP/EXIT**. The “SAVE CHANGES” display appears. There are five choices, as described below. Pressing the (–) or (+) key displays other choices and pressing **NEXT/SAVE** selects the displayed choice.



- **PERMANENT**—Permanently saves the changes. Values are stored in the printer even when power is turned off.
- **TEMPORARY**—Saves the changes until you change them again or until power is turned off.
- **CANCEL**—Cancels all changes from the time you pressed **SETUP/EXIT** except the darkness and tear-off settings (if they were changed).
- **LOAD DEFAULTS**—Loads factory defaults. The factory defaults are shown on the following pages.







NOTE: Loading factory defaults requires printer calibration.







- **LOAD LAST SAVE**—Loads values from the last permanent save.

Configuration and Calibration Sequence

Press	LCD Shows	Action/Explanation
—	PRINTER READY	Normal printer operation.
Setting Print Parameters		
 SETUP/EXIT	DARKNESS	<p>Adjusting Print Darkness: Press the (+) key to increase darkness; press the (–) key to decrease darkness. Default: +10 Range: 0 to +30</p> <p>Darkness settings are dependent on a variety of factors, including ribbon type, media, and the condition of the printhead. You may adjust the darkness for consistent high-quality printing.</p> <p>If printing is too light, or if there are voids in printed areas, increase the darkness. If printing is too dark, or if there is spreading or bleeding of printed areas, decrease the darkness. The FEED Key Self Test on page 84 can also be used to determine the best darkness setting. Since the darkness setting takes effect immediately, you can see the results on labels that are currently printing.</p> <p>CAUTION: Set the darkness to the lowest setting that provides good print quality. Darkness set too high may cause ink smearing and/or it may burn through the ribbon.</p> <p>Darkness settings also may be changed by the driver or software settings.</p>
 NEXT/SAVE	TEAR OFF	<p>Adjusting the Tear-Off Position: Press the (+) key to increase the value; press the (–) key to decrease the value. Each press of the key adjusts the tear-off position by four dot rows. Default: +0 Range: –120 to +120</p> <p>This parameter establishes the position of the media over the tear-off bar after printing. The label and liner can be torn off or cut between labels.</p>
 NEXT/SAVE	PRINT MODE	<p>Selecting Print Mode: Press the (+) or (–) key to display other choices. Default: Tear-Off Selections: Tear-Off, Peel-Off, Cutter, Rewind</p> <p>Print Mode settings tell the printer the method of media delivery that you wish to use. Select a Print Mode that your hardware configuration supports since some selections displayed are for optional printer features.</p>

Press	LCD Shows	Action/Explanation
 NEXT/SAVE	MEDIA TYPE	<p>Setting Media Type: Press the (+) or (–) key to display other choices.</p> <p>Default: Non-Continuous</p> <p>Selections: Continuous, non-continuous</p> <p>This parameter tells the printer the type of media you are using. Selecting continuous media requires that you include a label length instruction in your label format (^LLxxxxx if you are using ZPL or ZPL II).</p> <p>When non-continuous media is selected, the printer feeds media to calculate label length (the distance between two detections of the inter-label gap, webbing, or alignment notch or hole).</p>
 NEXT/SAVE	SENSOR TYPE	<p>Setting the Sensor Type: Press the (+) or (–) key to display other choices.</p> <p>Default: Web</p> <p>Selections: Web, mark</p> <p>This parameter tells the printer whether you are using media with a web (gap/space between labels, notch, or hole) to indicate the separations between labels or if you are using media with a black mark printed on the back. If your media does not have black marks on the back, leave your printer at the default (web).</p>
 NEXT/SAVE	PRINT METHOD	<p>Selecting Print Method: Press the (+) key for the next value; press the (–) key for the previous value.</p> <p>Default: Thermal transfer</p> <p>Selections: Thermal transfer, direct thermal</p> <p>The print method parameter tells the printer the method of printing you wish to use: direct thermal (no ribbon) or thermal transfer (using thermal transfer media and ribbon).</p> <p>NOTE: Selecting direct thermal when using thermal transfer media and ribbon creates a warning condition, but printing continues.</p>

Press	LCD Shows	Action/Explanation
 NEXT/SAVE	PRINT WIDTH	<p>Setting Print Width: Press the (+) key to increase the value, press the (–) key to toggle to a different digit. To change the unit of measurement, press the (–) key until the unit of measurement is active, then press the (+) key to toggle to a different unit of measure (inches, mm, or dots).</p> <p>Default; Range: The default and range of acceptable values vary depending on which printer you have. Refer to “Printing Specifications” on page 90 for further information about the ranges available for your model.</p> <p>Print width determines the printable area across the width of the label.</p>
 NEXT/SAVE	MAXIMUM LENGTH	<p>Setting Maximum Length: Press the (–) key to decrease the value, press the (+) key to increase the value.</p> <p>Default; Range: The default and range of acceptable values vary depending on your printer’s configuration. Values are adjustable in 1 in. (25.4 mm) increments.</p> <p>Maximum length is used in conjunction with the calibration procedure. The value of this setting determines the maximum label length used during the media portion of the calibration process. Only a few labels are needed to set media sensors. Always set the value that is closest to, but not lower than, the length of the label you are using. For example, if the length of the label is 14.5 in. (368 mm), set the parameter for 15.0 in. (381 mm).</p>

Listing Printer Information		
Press	LCD Shows	Action/Explanation
 NEXT/SAVE	LIST FONTS	List Fonts: Press the (+) key to print a label listing all available fonts. This selection is used to print a label listing all fonts available in the printer, including standard printer fonts plus any optional fonts. Fonts may be stored in RAM, Flash memory, font EPROMs, or font cards.
 NEXT/SAVE	LIST BAR CODES	List Bar Codes: Press the (+) key to print a label listing all available bar codes. This selection is used to print a label listing all bar codes available in the printer.
 NEXT/SAVE	LIST IMAGES	List Images: Press the (+) key to print a label listing all available images. This selection is used to print a label listing all images stored in the printer's RAM, Flash memory, optional EPROM, or optional memory card.
 NEXT/SAVE	LIST FORMATS	List Formats: Press the (+) key to print a label listing all available formats. This selection is used to print a label listing all formats stored in the printer's RAM, Flash memory, optional EPROM, or optional memory card.
 NEXT/SAVE	LIST SETUP	List Setup: Press the (+) key to print a label listing the current printer configuration. This selection is used to print a label that lists the current printer configuration information. (Same as CANCEL Key Self Test.)
 NEXT/SAVE	LIST ALL	List All: Press the (+) key to print a label listing all available fonts, bar codes, images, formats, and the current printer configuration. This selection is used to print a label that lists the five previous selections, as described.

Media and Ribbon Sensor Calibration

NOTE: Before you begin this procedure, make sure that the maximum length is set to a value equal to or greater than the length of the labels you are using. If the maximum length is set to a lower value, the calibration process assumes that continuous media is in the printer. See [page 50](#) for more information.

There are two different types of calibration that can be performed by the printer:

1) Auto Calibration. When the printer is turned on after the printhead has been closed, the printer feeds media and automatically sets the value it detects for media, media liner (the spaces between labels), and media out. This type of calibration also occurs as part of the sensor profile and media and ribbon calibration procedures.

2) Media and Ribbon Sensor Sensitivity Calibration. Performing the media and ribbon calibration procedure first resets the sensitivity of the sensors to better detect the media and ribbon you are using. With the sensors at their new sensitivity, the printer then performs the auto calibration described above. Changing the type of ribbon and/or media may require resetting the sensitivity of the media and ribbon sensors. Indications that the sensitivity may need to be reset include an illuminated CHECK RIBBON light with the ribbon properly installed or non-continuous media being treated as continuous media.

Press	LCD Shows	Action/Explanation
 NEXT/SAVE	SENSOR PROFILE	<p>Sensor Profile: Press NEXT/SAVE to skip this standard calibration procedure and continue with the media and ribbon calibration parameter on the next page. Press the (+) key to initiate this standard calibration procedure and print a media sensor profile.</p> <p>See Figure 26. The media sensor profile may be used to troubleshoot registration problems that may be caused when the media sensor detects preprinted areas on the media or experiences difficulty in determining web location. If the sensitivity of the media and/or ribbon sensors must be adjusted, use the media and ribbon sensor sensitivity procedure.</p>

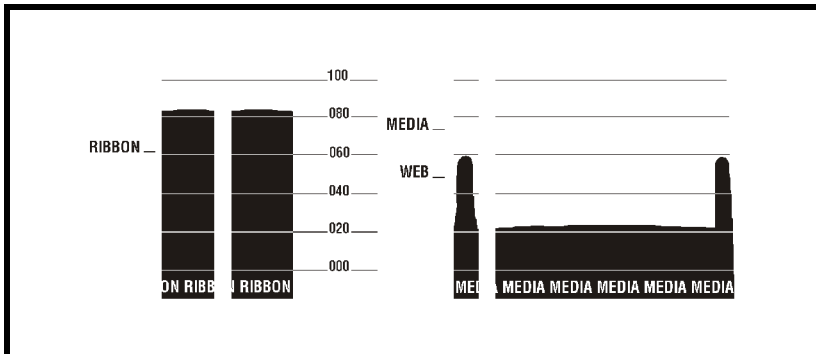



















Figure 26. Media Sensor Profile



Press	LCD Shows	Action/Explanation
 NEXT/SAVE	MEDIA AND RIBBON CALIBRATE	<p>Media and Ribbon Sensor Sensitivity: Press NEXT/SAVE to skip the calibration procedure and continue with the host port selection parameters that follow. Press the (+) key to start the calibration procedure.</p> <p>This procedure is used to adjust the sensitivity of the media and ribbon sensors.</p> <p>NOTE: The procedure must be followed exactly as presented. All steps must be performed even if only one of the sensors requires adjustment.</p>
Media and Ribbon Calibration Procedure		
	LOAD BACKING	<ol style="list-style-type: none"> 1) Open the printhead. 2) Remove approximately 8 in. (200 mm) of labels from the media roll, enough so that only the liner material is threaded between the media sensors when the media is loaded. 3) Close the printhead. <p>NOTE: To cancel the operation, press the (–) key.</p>
	REMOVE RIBBON	<ol style="list-style-type: none"> 1) Open the printhead. 2) Remove the ribbon (sliding it as far to the right as possible has the same effect as removing it). 3) Close the printhead. <p>NOTE: To cancel the operation, press the (–) key.</p>
	CALIBRATING PLEASE WAIT	<p>The printer automatically adjusts the scale (gain) of the signals it receives from the media and ribbon sensors based on the specific media and ribbon combination you are using. On the sensor profile, this corresponds to moving the graph up or down to optimize the readings for your application.</p>
–	RELOAD ALL	<p>When “RELOAD ALL” is displayed:</p> <ol style="list-style-type: none"> 1) Open the printhead and pull the media forward until a label is positioned under the media sensor. 2) Move the ribbon back to its proper position. 3) Close the printhead.
	MEDIA AND RIBBON CALIBRATE	<p>Now that the scale has changed, the printer performs another calibration. During this process, the printer checks the readings for the media and ribbon based on the new scale you have established, determines the label length, and determines whether you are in Direct Thermal or Thermal Transfer Print Mode. The process is now complete! To see the new readings on the new scale, print a sensor profile.</p>



Setting Communication Parameters		
<p>Communication parameters must be set correctly for the printer to communicate with the host computer. These parameters ensure that the printer and host computer are “speaking the same language.” All communications parameters are password protected.</p>		
Press	LCD Shows	Action/Explanation
 NEXT/SAVE	SERIAL COMM	<p>Setting Serial Communications: Press the (+) or (–) key to display other choices. Default: RS-232 Selections: RS-232, RS-422/485, RS-485 multidrop Select the communications port that matches the one being used by the host computer.</p>
 NEXT/SAVE	PARALLEL COMM	<p>Setting Parallel Communications: Press the (+) or (–) key to display other choices. Default: Parallel Selections: Parallel, twinax/coax Select the communications port that matches the one being used by the host computer.</p>
 NEXT/SAVE	BAUD	<p>Setting Baud: Press the (+) or (–) key to display other choices. Default: 9600 Selections: 110, 300, 600, 1200, 2400, 4800, 9600, 14400, 19200, 28800, 38400, 57600, 115200 The baud setting of the printer must match the baud setting of the host computer for accurate communications to take place. Select the value that matches the one being used by the host computer.</p>
 NEXT/SAVE	DATA BITS	<p>Setting Data Bits: Press the (+) or (–) key to display other choices. Default: 7bits Selections: 7bits, 8 bits The data bits of the printer must match the data bits of the host computer for accurate communications to take place. Set the data bits to match the setting being used by the host computer. NOTE: This setting must be set to 8 data bits to use Code Page 850.</p>

Press	LCD Shows	Action/Explanation
 NEXT/SAVE	PARITY	<p>Setting Parity: Press the (+) or (–) key to display other choices. Default: Even Selections: Even, odd, none</p> <p>The parity of the printer must match the parity of the host computer for accurate communications to take place. Select the parity that matches the one being used by the host computer.</p>
 NEXT/SAVE	STOP BITS	<p>NOTE: Depending on the model you have, this menu item may not be available. Setting Stop Bits: Press the (+) or (–) key to display other choices. Default: 1 stop bit Selections: 1 stop bit, 2 stop bits</p> <p>The stop bits of the printer must match the stop bits of the host computer for accurate communications to take place. Select the stop bits that match the one being used by the host computer.</p>
 NEXT/SAVE	HOST HANDSHAKE	<p>Setting Host Handshake: Press the (+) or (–) key to display other choices. Default: XON/XOFF Selections: XON/XOFF, DTR/DSR, RTS/CTS</p> <p>The handshake protocol of the printer must match the handshake protocol of the host computer for communications to take place. Select the handshake protocol that matches the one being used by the host computer.</p>
 NEXT/SAVE	PROTOCOL	<p>Setting Protocol: Press the (+) or (–) key to display other choices. Default: None Selections: None, Zebra, ACK/NACK</p> <p>Protocol is a type of error-checking system. Depending on the selection, an indicator may be sent from the printer to the host computer signifying that data has been received. Select the protocol that is requested by the host computer. Further details on protocol can be found in the <i>ZPL II Programming Guide Volume I</i>.</p> <p>NOTES: Zebra is the same as ACK/NACK, except that Zebra response messages are in packets. If Zebra is selected, printer must use either “DTR/DSR” or “RTS/CTS” host handshake protocol. Protocol error works in Serial Mode only.</p>

 NEXT/SAVE	NETWORK ID	<p>Setting Network ID: Press the (–) key to move to the next digit position; press the (+) key to increase the value of the digit. Default: 000 Range: 000–999</p> <p>Network ID is used to assign a unique number to a printer used in an RS-422/RS-485 network. This gives the host computer the means to address a specific printer. If the printer is used in a network, you must select a network ID number. This does not affect TCP/IP or IPX networks.</p>
 NEXT/SAVE	COMMUNICATIONS	<p>Setting Communications Mode: Press the (+) or (–) key to display other choices. Default: Normal mode Selections: Normal mode, diagnostics</p> <p>The Communication Diagnostics Mode is a troubleshooting tool for checking the interconnection between the printer and the host computer. When “diagnostics” is selected, all data sent from the host computer to the printer is printed as straight ASCII hex characters. The printer prints all characters received, including control codes, such as CR (carriage return). A sample printout is shown in Figure 36 on page 85.</p> <p>NOTES on diagnostic printouts:</p> <ul style="list-style-type: none"> • FE indicates a framing error. • OE indicates an overrun error. • PE indicates a parity error. • NE indicates noise. <p>For any errors, check that your communication parameters are correct. Set the print width equal to or less than the label width used for the test. See page 50 for more information.</p>

Press	LCD Shows	Action/Explanation
<p>Selecting Prefix and Delimiter Characters</p> <p>Prefix and delimiter characters are 2-digit hex values used within the ZPL/ZPL II formats sent to the printer. The printer uses the last prefix and delimiter characters sent to it, whether from a ZPL II instruction or from the front panel.</p> <p>NOTE: Do not use the same hex value for the control, format, and delimiter character. The printer needs to see different characters to function properly.</p>		
 NEXT/SAVE	CONTROL PREFIX	<p>Control Prefix Character: Press the (–) key to move to the next digit position; press the (+) key to increase the value of the digit. Default: 7E (tilde—displayed as a black square) Range: 00–FF The printer looks for this 2-digit hex character to indicate the start of a ZPL/ZPL II control instruction.</p>
 NEXT/SAVE	FORMAT PREFIX	<p>Format Prefix Character: Press the (–) key to move to the next digit position; press the (+) key to increase the value of the digit. Default: 5E (caret) Range: 00–FF The printer looks for this 2-digit hex character to indicate the start of a ZPL/ZPL II format instruction.</p>
 NEXT/SAVE	DELIMITER CHAR	<p>Delimiter Character: Press the (–) key to move to the next digit position; press the (+) key to increase the value of the digit. Default: 2C (comma) Range: 00–FF The delimiter character is a 2-digit hex value used as a parameter place marker in ZPL/ZPL II format instructions. Refer to the <i>ZPL II Programming Guide Volume I</i> for more information.</p>

Selecting ZPL Mode		
Press	LCD Shows	Action/Explanation
 NEXT/SAVE	ZPL MODE	<p>Selecting ZPL Mode: Press the (+) or (–) key to display other choices.</p> <p>Default: ZPL II</p> <p>Selections: ZPL II, ZPL</p> <p>The printer remains in the selected mode until it is changed by this front panel instruction or by using a ZPL/ZPL II command. The printer accepts label formats written in either ZPL or ZPL II. This eliminates the need to rewrite any ZPL formats you already have. Refer to the <i>ZPL II Programming Guide Volume II</i> for more information on the differences between ZPL and ZPL II.</p>
Power-Up and Head Close Parameters		
 NEXT/SAVE	MEDIA POWER UP	<p>Media Power-Up: Press the (+) or (–) key to display other choices.</p> <p>Default: Calibration</p> <p>Selections: Feed, calibration, length, and no motion</p> <p>This parameter establishes the action of the media when the printer is turned on.</p> <ul style="list-style-type: none"> • Calibration: Recalibrates the media sensors. • Feed: Feeds the label to the first web. • Length: Determines the length of the label. • No Motion: Media does not move.
 NEXT/SAVE	HEAD CLOSE	<p>Head Close: Press the (+) or (–) key to display other choices.</p> <p>Default: Calibration</p> <p>Selections: Feed, calibration, length, no motion</p> <p>Determines the action of the media after the printhead has been opened and then closed.</p> <ul style="list-style-type: none"> • Calibration: Recalibrates the media sensors. • Feed: Feeds the label to the first web. • Length: Determines the length of the label. • No Motion: Media does not move.

Label Positioning Parameters		
Press	LCD Shows	Action/Explanation
 NEXT/SAVE	BACKFEED	<p>Backfeed Sequence: Press the (+) or (–) key to display other choices.</p> <p>Default: Default (90%)</p> <p>Selections: Default, after, before, 10%, 20%, 30%, 40%, 50%, 60%, 70%, 80%, off</p> <p>This parameter establishes when and how much label backfeed occurs after a label is removed or cut in Peel-Off, Cutter, and Applicator Modes. It has no effect in Rewind or Tear-Off Modes. This parameter setting can be superseded by the ~JS instruction when received as part of a label format (refer to the <i>ZPL II Programming Guide Volume I</i>).</p> <p>NOTE: The difference between the value entered and 100% establishes how much backfeed occurs before the next label is printed. For example, a value of 40 means that 40% of the backfeed takes place after the label is removed or cut. The remaining 60% takes place before the next label is printed. A value of “before” means that all backfeed takes place before the next label is printed.</p>
 NEXT/SAVE	LABEL TOP	<p>Adjusting Label Top Position: Press the (+) key to increase the value; press the (–) key to decrease the value. The displayed value represents dots.</p> <p>Default: +0</p> <p>Range: –120 to +120 dot rows</p> <p>The label top position adjusts the print position vertically on the label. Positive numbers adjust the label top position further down the label (away from the printhead), negative numbers adjust the position up the label (toward the printhead).</p>
 NEXT/SAVE	LEFT POSITION	<p>Adjusting Left Position: Press the (–) key to move to the next position, press the (+) key to change between + and to increase the value of the digit. The displayed value represents dots.</p> <p>Default: 0000</p> <p>Range: –9999 to +9999</p> <p>NOTE: For a negative value, enter the value before changing to the minus sign.</p> <p>This parameter establishes how far from the left edge of a label the format begins to print by adjusting horizontal positioning on the label. Positive numbers adjust the printing to the left by the number of dots selected; negative numbers shift printing to the right.</p>

	<p>HEAD RESISTOR</p>	<p>NOTE: Depending on the model you have, this menu item may not be available. Newer printer models automatically set the head resistor value after the printhead has been replaced. For printers with model numbers 10500-2XXX-XXXX and 10500-3XXX-XXXX, the head resistor value is set automatically.</p> <p>Setting the Head Resistor Value: Press the (-) key to move to the next digit position; press the (+) key to increase the value of the digit.</p> <p>CAUTION: This parameter should be changed only by qualified personnel!</p> <p>Initial Value: Factory-set to match the printhead shipped with your printer.</p> <p>Default Value: 0500</p> <p>Range: 0500 to 1175</p> <p>This value has been preset at the factory to match the resistance value of the printhead. It does not need to be changed unless the printhead is replaced.</p> <p>CAUTION: Do not set the value higher than that shown on the printhead. Setting a higher value may damage the printhead!</p> <p>Before replacing the printhead, look for the label that shows the resistance value (ohm value) of the new printhead and note it for the setting.</p>
---	----------------------	---

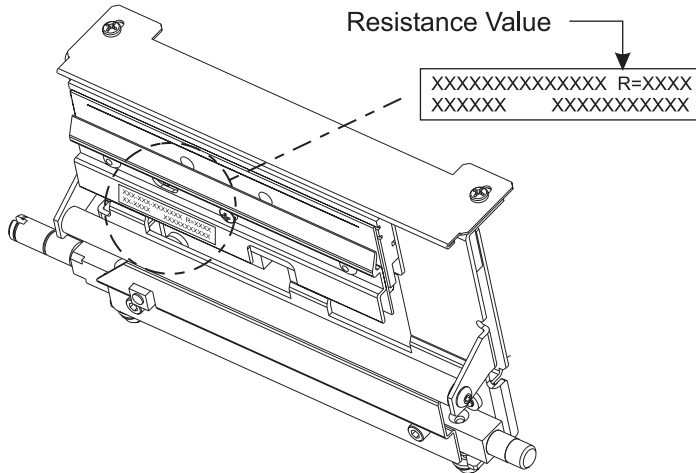



















Figure 27. Head Resistance Value

Press	LCD Shows	Action/Explanation
 NEXT/SAVE	WEB S.	<p>CAUTION: These parameters are automatically set during the calibration procedure. They should be changed only by a qualified service technician. Refer to the maintenance manual for more information on these parameters.</p> <p>Press NEXT/SAVE repeatedly to skip these parameters.</p>
 NEXT/SAVE	MEDIA S.	
 NEXT/SAVE	RIBBON S.	
 NEXT/SAVE	MARK S.	
 NEXT/SAVE	MARK MED S.	
 NEXT/SAVE	RIBBON LED	
 NEXT/SAVE	MARK LED	
 NEXT/SAVE	LCD ADJUST	<p>LCD Display Adjustment: Press the (–) key to decrease the value (reduce brightness); press the (+) key to increase the value (increase brightness).</p> <p>Range: 00 to 19</p> <p>This parameter allows you to adjust the brightness of your LCD if it is difficult to read.</p>
 NEXT/SAVE	FORMAT CONVERT	<p>Format Convert: Press the (+) or (–) key to display other choices.</p> <p>Default: None</p> <p>Selections: None, 150 → 300, 150 → 600, 200 → 600, 300 → 600</p> <p>Selects the bitmap scaling factor. The first number is the original dots per inch (dpi) value; the second, the dpi to which you would like to scale.</p>

Press	LCD Shows	Action/Explanation
 NEXT/SAVE	IP RESOLUTION*	<p>IP Resolution: Press the (+) or (-) key to display other choices. Default: Dynamic Selections: Dynamic, permanent Depending on the selection, allows either the user (“permanent”) or the server (“dynamic”) to select the IP address. For more information, refer to <i>ZebraNet Networking: PrintServer II User and Reference Guide</i>.</p>
 NEXT/SAVE	IP PROTOCOLS*	<p>IP Protocols: Press the (+) or (-) key to display other choices. Default: All Selections: All, gleaning only, RARP, BOOTP, DHCP, DHCP/BOOTP If “dynamic” was chosen in the previous parameter, this selection determines the method(s) by which the PrintServer II receives the IP address from the server. For more information, refer to <i>ZebraNet Networking: PrintServer II User and Reference Guide</i>.</p>
 NEXT/SAVE	IP ADDRESS*	<p>IP Address: Press the (-) key to move to the next digit position; press the (+) key to increase the value of the digit. This parameter allows you to select the IP address if “permanent” was chosen in “IP RESOLUTION.” If “dynamic” was chosen, the user cannot select the address. For more information, refer to <i>ZebraNet Networking: PrintServer II User and Reference Guide</i>.</p>
 NEXT/SAVE	SUBNET MASK*	<p>Subnet Mask: Press the (+) or (-) key to display other choices. Default: Permanent (user <i>must</i> set) Selections: Dynamic (user <i>may</i> set, but server can assign), permanent This parameter selects the part of the IP address that is considered to be part of the local network. It can be reached without going through the default gateway.</p>
 NEXT/SAVE	DEFAULT GATEWAY*	<p>Default Gateway: Press the (-) key to move to the next digit position; press the (+) key to increase the value of the digit. This parameter allows you to select the IP address that the network traffic is routed through if the destination address is not part of the local network.</p>

* ZebraNet PrintServer II option required

Press	LCD Shows	Action/Explanation
 NEXT/SAVE	LANGUAGE	<p>Selecting the Display Language: Press the (+) or (-) key to display other choices. Default: English Selections: English, Spanish, French, German, Italian, Norwegian, Portuguese, Swedish, Danish, Dutch, Finnish, and Japanese This parameter allows you to change the language displayed on the LCD.</p>
<p>You have completed the entire configuration and calibration sequence. You may press either NEXT/SAVE or SETUP/EXIT.</p>		
 NEXT/SAVE	DARKNESS	<p>You are now back at the first parameter in the configuration sequence.</p> <p>NOTE: If you pressed NEXT/SAVE but are through programming the printer configuration, you may press SETUP/EXIT and continue with the “SAVE SETTINGS” function.</p>
 SETUP/EXIT	SAVE CHANGES	<p>Save Changes: Press the (+) or (-) key to display other choices. Default: Permanent Selections: Permanent, temporary, cancel, load defaults, load last save.</p> <p>This display appears when you attempt to exit Setup Mode.</p> <ul style="list-style-type: none"> • <i>Permanent:</i> Permanently saves the changes, even when printer power is turned off. • <i>Temporary:</i> Saves the changes until changed again or until power is turned off. • <i>Cancel:</i> Cancels all changes since you entered Setup Mode except for darkness and tear-off position (if they were changed). • <i>Load defaults:</i> Loads factory defaults. <p>NOTE: Loading factory defaults requires calibration.</p> <ul style="list-style-type: none"> • <i>Load last save:</i> Loads the values from the last permanent save.
 NEXT/SAVE	PRINTER READY	<p>Press NEXT/SAVE to activate the displayed choice. You have exited the configuration and calibration sequence and are ready for normal printer operation.</p>



Routine Care and Adjustment

Cleaning

The table below provides a brief cleaning schedule. Specific cleaning procedures are provided on the following pages.

Area	Method	Interval
Printhead	Solvent*	Direct Thermal Print Mode: After every roll of media (500 ft. or 50 m of media). Thermal Transfer Print Mode: After every roll (1500 ft. or 450m) of ribbon.
Platen roller	Solvent*	
Transmissive sensor	Air blow	
Black mark sensor	Air blow	
Media path	Solvent*	
Ribbon sensor	Air blow	
Label available sensors	Air blow	Monthly
Tear-off bar	Solvent*	As needed
Snap plate	Solvent*	
Cutter	Solvent*	
* Zebra recommends using a solvent of 90% isopropyl alcohol.		

CAUTION: Use only the cleaning agents indicated. Zebra Technologies is not responsible for any other fluids used on this printer.



Cleaning the Exterior

The exterior surfaces of the printer may be cleaned with a lint-free cloth. Do not use harsh or abrasive cleaning agents or solvents. If necessary, a mild detergent solution or desktop cleaner may be used sparingly.

Cleaning the Interior

Inspect this area after every four rolls of media. Remove any dirt and lint from the interior of the printer using a soft bristle brush and/or vacuum cleaner.

Cleaning the Printhead and Platen Roller

Inconsistent print quality, such as voids in the bar code or graphics, may indicate a dirty printhead. For best results, perform the following cleaning procedure after every roll of ribbon.



NOTE: You do not need to turn off the printer before cleaning the printhead. If power is turned off, all label formats and images, as well as any temporarily saved parameter settings stored in the printer's internal memory, are lost. When power is turned back on, you need to reload these items.

To clean the printhead, refer to [Figure 28](#) and follow these steps:

1. Open the printhead.
2. Remove the media and ribbon (if loaded).
3. Moisten an applicator tip with a solvent containing 90% isopropyl alcohol, and wipe along the print elements from end to end. (The print elements are on the brown strip just behind the chrome strip on the printhead.) Allow a few seconds for the solvent to evaporate.



4. Rotate the platen roller and clean thoroughly with solvent and an applicator.
5. Brush/vacuum any accumulated paper lint and dust away from the rollers.
6. Reload ribbon and/or media, and close the printhead.



NOTE: If print quality has not improved after performing this procedure, try cleaning the printhead with *Save-a-Printhead* cleaning film. This specially-coated material removes contamination buildup without damaging the printhead. Please see Appendix D or call your authorized Zebra reseller or distributor for more information.

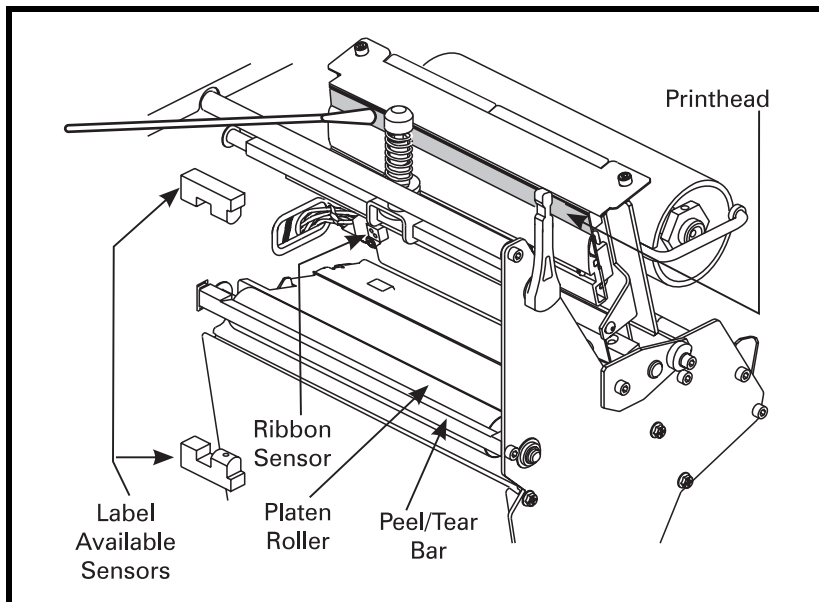

Figure 28. Printhead and Platen Roller Cleaning

Cleaning the Sensors

The media, ribbon, and label available sensors should be cleaned on a regular basis to ensure proper operation of the printer. To locate these sensors, refer to [Figure 28](#) on [page 67](#), [Figure 6](#) on [page 11](#), and [Figure 7](#) on [page 12](#). Brush or vacuum any accumulated paper lint and dust off of these sensors.

Cleaning the Snap Plate

Clean the snap plate to remove label adhesive or a label that has adhered to the underside of the snap plate.

Refer to [Figure 29](#).

1. Insert a small-blade screwdriver or similar tool into the loop on the left side of the snap plate. Lift the snap plate.

CAUTION: Do **not** bend, twist, or otherwise deform the loops! If the snap plate is damaged in any way, a new plate may be required for proper ribbon sensing.

2. Repeat step 1 on the right side of the snap plate.
3. Remove the snap plate from the printer.
4. Clean the snap plate with cleaning solvent and a soft cloth.

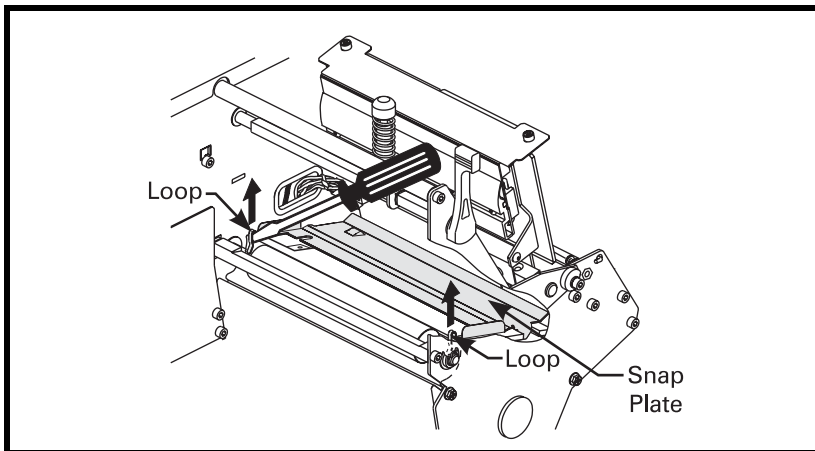

Figure 29. Snap Plate Removal and Cleaning



Refer to [Figure 30](#).

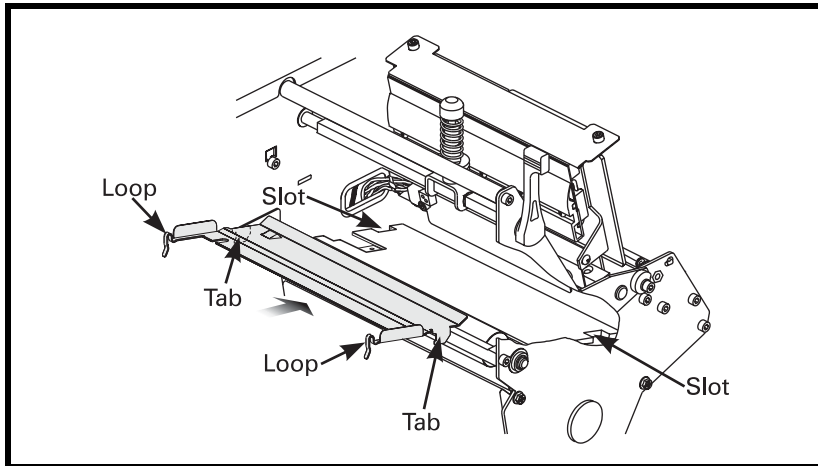

Figure 30. Snap Plate Reinstallation

5. To reinstall the snap plate, insert the two tabs on the bottom of the snap plate into the two slots of the media pathway.
6. Slide the snap plate toward you.
7. Press down on the loops to lock the snap plate into place.



Cleaning the Cutter Module

(For printers equipped with the optional cutter.)

If labels are not being cut properly or if the cutter jams with labels, turn off the printer power (●) and unplug the printer. Then, clean the stationary cutter blade with cleaning solvent. This removes label adhesive and/or paper debris. If further cutter cleaning is necessary, or if the cutter continues to perform unsatisfactorily, contact an authorized service technician.



NOTE: Turning off the printer results in the loss of label formats, images, and any temporarily saved parameter settings stored in the printer's internal memory. Perform this procedure after your printing job is complete.

Lubrication

CAUTION: No lubricating agents other than Zebra-supplied, silicon-only lubricants should be used on the spindle felt clutches of this printer. Other commercially available lubricants damage the finish and mechanical parts.



Fuse Replacement

The printer uses a metric-style fuse (5 × 20 mm IEC) rated at F5A, 250V. The end caps of the fuse must bear the certification mark of a known international safety organization (see [Figure 38](#) on [page 93](#)).

Depending on the model you have, the fuse may not be user-replaceable (see [Figure 31](#)) and may need to be replaced by a qualified service technician. Please see the maintenance manual (part number 32056L) for details.

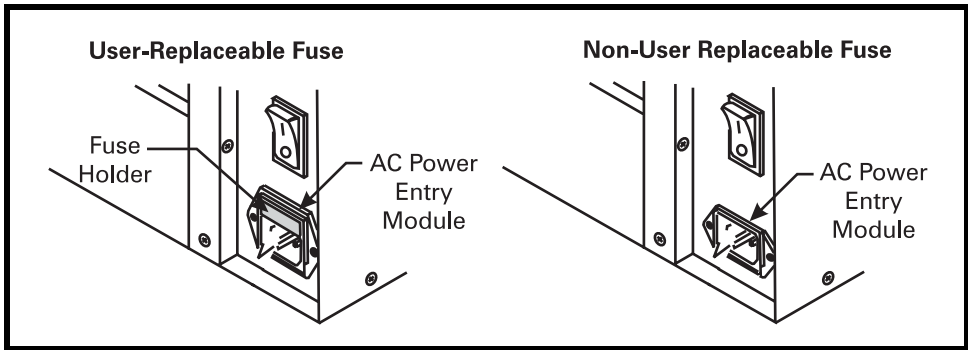

Figure 31. Fuse Replacement



NOTE: Models with a user-replaceable fuse have a warning label next to the fuse for easy identification.

Adjustments

Toggle Positioning

See [Figure 32](#).

The toggle should be positioned so that it provides even pressure on the media. Position the toggle by sliding it to the desired location.

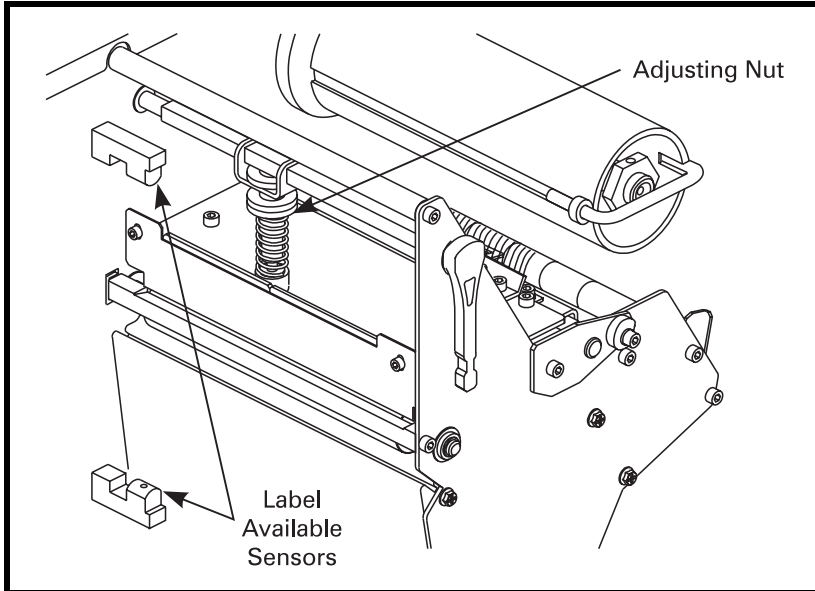

Figure 32. Toggle Adjustment



Printhead Pressure Adjustment

This adjustment may be necessary if printing is too light on one side or if thick media is used. Refer to [Figure 32](#).

1. Perform the toggle positioning procedure. If the problem is solved, you may stop here; otherwise, continue with the rest of this procedure.
2. Print some labels at speed A by running the PAUSE Key Self Test (see [page 83](#)).
3. While printing labels, lower the darkness setting until you see a gray level of printing.
4. Loosen the knurled (upper) locking nuts at the top of the toggle assembly/assemblies.
5. Increase or decrease spring pressure using the knurled (lower) adjusting nuts on the shafts of the toggle until the left and right edges of the printed area are equally dark.



NOTE: Printhead life can be maximized by using the lowest pressure that produces the desired print quality.

6. Increase darkness setting to the optimum level for the media being used.
7. Re-tighten locking nuts.

Media Sensor Position Adjustment

See “[Positioning the Media Sensors](#)” on [page 10](#).



Troubleshooting

LED Error Conditions and Warnings

Error Condition“ Ribbon Out

Problem	Solution
In Thermal Transfer Mode, the ribbon is not loaded <i>or</i> loaded incorrectly.	Load the ribbon correctly. See “Ribbon Loading” on page 41 .
In Thermal Transfer Mode, the ribbon sensor is not sensing correctly loaded ribbon.	Perform the media and ribbon sensor calibration (see page 17).
In Direct Thermal Mode, when ribbon is not used:	Put the printer in Direct Thermal Mode via the front panel and remove ribbon (if loaded).
	Ensure that the printer driver or software settings are correctly set (if applicable).

Error Condition“ Paper Out

Problem	Solution
The media is not loaded or loaded incorrectly.	Reload the media. Refer to “Roll Media Loading” on page 29 .
The media sensor is not adjusted properly.	Check the position of the upper and lower media sensors. See “Positioning the Media Sensors” on page 10 .
The printer is set for non-continuous media, but continuous media is loaded.	Either load the correct media or set the printer for the correct media type via the front panel.
	Ensure that the printer driver or software settings are correctly set (if applicable).
	Calibrate the printer (see page 17).

The incorrect media sensor is being used.	Via the front panel, check the sensor type to ensure that the correct one is used for the media loaded. See page 16 . Calibrate the printer (see page 17).
The maximum label length is set shorter than the label length being used.	Via the front panel, set the label length to a value that is slightly longer than the length of the label being used.

Error Condition“ Head Open

Problem	Solution
The printhead is not fully closed.	Close the printhead.

Warning“ Ribbon In

Problem	Solution
The ribbon is loaded.	Remove the ribbon and set the printer to Direct Thermal Mode.
	Ensure that the printer driver and/or software settings are correctly set (if applicable).

Warning“ Head Too Hot

Problem	Solution
The printhead is over temperature.	Allow the printer to cool. Printing automatically resumes when the printhead elements cool to an acceptable operating temperature.

Warning“ Head Cold

Problem	Solution
The printhead is under temperature.	Continue printing while the printhead reaches the correct operating temperature. If the error remains, the environment may be too cold for proper printing. Relocate the printer to a warmer area.

<p>Printhead data cable is not properly connected.</p>	<p>WARNING: The printhead can be very hot and can cause severe burns. Allow the printhead to cool. Disconnect and reconnect data cable to the printhead. Ensure that the cable connector is fully inserted into the printhead connector.</p>
--	---

Warning“ Cutter Jammed

Problem	Solution
<p>Cutter blade is in the media path.</p>	<p>Turn off the printer power and unplug the printer. Inspect the cutter module for debris and clean as needed following the cleaning instructions on page 70.</p>

Out of Memory*

Problem	Solution
<p>*There is not enough memory to perform the function shown on the second line of the error message.</p>	<p>Insufficient memory for the label length, downloaded fonts/graphics, and images.</p>
	<p>Ensure that the device, such as Flash memory or PCMCIA card, is installed and not write-protected or full.</p>
	<p>Ensure that the data is not directed to a device that is not installed or available.</p>

Print Quality Problems

General Print Quality Issues

Problem	Solution
<p>You are using an incorrect media and ribbon combination for your application.</p>	<p>Consult your authorized Zebra reseller/distributor for information and advice.</p>
<p>The printer is set at the incorrect print speed.</p>	<p>For optimal print quality, set the print speed to the lowest possible setting via ZPL II, the driver, or the software.</p>

The printer is set at the incorrect darkness level.	For optimal print quality, set the darkness to the lowest possible setting via the front panel, the driver, or the software.
The printhead is dirty.	Clean the printhead according to the instructions on page 66 .
There is light printing (or no printing) on the left or right side of the label or the printed image is not sharp.	The toggle pressure needs to be adjusted. Follow the printhead pressure adjustment instructions on page 73 .

Gray lines on blank labels with no consistent pattern

Problem	Solution
The printhead is dirty.	Clean the printhead according to the instructions on page 66 .

Light, consistent vertical lines running through all of the labels

Problem	Solution
The printhead or platen roller is dirty.	Clean the printhead, platen roller, or both according to the instructions on page 66 .

Intermittent creases on the left and right edges of the labels

Problem	Solution
There is too much toggle pressure on the printhead.	Reduce the toggle pressure. See " Printhead Pressure Adjustment " on page 73 .

Wrinkled Ribbon

Problem	Solution
The ribbon is not loaded correctly.	Load the ribbon correctly. See "Ribbon Loading" on page 41 .
The darkness setting is incorrect.	Set the darkness to the lowest possible setting for good print quality. See "DARKNESS" on page 48 .
Incorrect printhead pressure or balance.	Set the pressure to the minimum required for good print quality. See "Printhead Pressure Adjustment" on page 73 .
The media is not feeding correctly. It is "walking" from side to side.	Make sure that the media guide and media supply guide touch the edge of the media.

Communications

A label format was sent to the printer but not recognized. The DATA light does not flash.

Problem	Solution
The communication parameters are incorrect.	Check the printer driver or software communications settings (if applicable).
	Check the printer host port setting via the front panel (see page 54). Select the port that matches the one being used by the host computer.
	Ensure you are using the correct communication cable. See page 23 for the requirements.
	Via the front panel, check the protocol setting. It should be set to "none." See page 54 .
	Ensure that the correct driver is being used, if applicable.

A label format was sent to the printer. Several labels print, then the printer skips, misplaces, misses, or distorts the image on the label.

Problem	Solution
The host computer is set to EPP parallel communications.	Change the settings on the host computer to standard parallel communications.
The serial communication settings are incorrect.	Ensure that the flow control settings match.
	Check the communication cable length. See page 54 for requirements.
	Check the printer driver or software communications settings (if applicable).

A label format was sent to the printer but not recognized. The DATA light flashes but no printing occurs.

Problem	Solution
The prefix and delimiter characters set in the printer do not match the ones in the label format.	Verify the prefix and delimiter characters. See “Selecting Prefix and Delimiter Characters” on page 57 .
Incorrect data is being sent to the printer.	Ensure that ZPL is being used.
	Check the communication settings on the host computer. Ensure that they match the printer settings.

The printer fails to calibrate or detect the top of the label.

Problem	Solution
The printer was not calibrated for the label being used.	Perform the calibration procedure on page 17 .
The printer is configured for continuous media.	Set the media type to non-continuous media.
The driver or software configuration is not set correctly.	As driver or software settings produce ZPL commands that can overwrite the printer configuration, check the driver or software media-related setting.



Printer Diagnostics

Power-On Self Test

A full Power-On Self Test (POST) is performed automatically each time the printer is turned on (additional self tests can be performed by pressing **CANCEL** when you turn the printer on). During either test sequence, the front panel lights and LCD monitor the progress of the POST. If the printer fails any of these tests, the word “FAILED” is added to the LCD. If this occurs, notify an authorized Zebra reseller.

Additional Printer Self Tests

These self tests produce sample printouts and provide specific information that help determine the operating conditions for the printer.

Each self test is enabled by pressing a specific front panel key or combination of keys while turning the **POWER** on (**I**). Keep the key(s) depressed until the **DATA** light turns off. When the POST is complete, the selected self test starts automatically.



NOTE: When performing self tests, avoid sending a label format to the printer. In the case of a remote host, disconnect all data interface cables from the printer. When cancelling a self test prior to its actual completion, always turn the printer power off and then back on to reset the printer.

When performing these self tests while in Peel-Off Mode, you must remove the labels as they become available.

If your media is not wide enough or long enough, unexpected or undesired results may occur. Make sure that your print width is set correctly for the media you are using before you run any self tests, otherwise the test may print out on the platen roller. See [page 50](#) for information on setting the print width.

CANCEL Key Self Test

This self test prints a listing of the configuration parameters currently stored in the printer's memory. See [Figure 33](#) (depending on the options ordered, your label may look different).

1. Turn the printer off (O).
2. Press and hold CANCEL while turning on the power (I).

The configuration may be changed either temporarily (for specific label formats or ribbon and label stock) or permanently (by saving the new parameters in memory). Saving new parameters occurs whenever a calibration procedure is performed. Refer to [page 15](#) for further information about the configuration procedure. Additional Power-Up Self Tests are also performed during the POST for this test.

PRINTER CONFIGURATION	
Zebra Technologies ZTC 105SL-200dpi	
+10.....	DARKNESS
+000.....	TEAR OFF
TEAR OFF.....	PRINT MODE
CONTINUOUS.....	MEDIA TYPE
WEB.....	SENSOR TYPE
THERMAL-TRANS.....	PRINT METHOD
104 0/8 MM.....	PRINT WIDTH
1200.....	LABEL LENGTH
8.01IN 202MM.....	MAXIMUM LENGTH
PARALLEL.....	PARALLEL COMM.
RS232.....	SERIAL COMM.
57600.....	BAUD
8 BITS.....	DATA BITS
NONE.....	PARITY
NONE/XOFF.....	HOST HANDSHAKE
NONE.....	PROTOCOL
000.....	NETWORK ID
NORMAL MODE.....	COMMUNICATIONS
<?> 7EH.....	CONTROL PREFIX
<?> 5EH.....	FORMAT PREFIX
<.> 2CH.....	DELIMITER CHAR
ZPL II.....	ZPL MODE
CALIBRATION.....	MEDIA POWER UP
CALIBRATION.....	HEAD CLOSE
DEFAULT.....	BACKFEED
+000.....	LABEL TOP
+0000.....	LEFT POSITION
070.....	WEB S.
070.....	MEDIA S.
072.....	RIBBON S.
045.....	MARK S.
080.....	MARK MED S.
075.....	MEDIA LED
015.....	RIBBON LED
037.....	MARK LED
NONE.....	LCD ADJUST
DPSNFXM.....	MODES ENABLED
832 8/MM FULL.....	MODES DISABLED
V41.11.0 <-.....	RESOLUTION
V02.0.0.....	FIRMWARE
CUSTOMIZED.....	HARDWARE ID
8192.....R:	CONFIGURATION
NONE.....B:	RAM
0768.....E:	MEMORY CARD
NONE.....	ONBOARD FLASH
005 DISPLAY.....	FORMAT CONVERT
DYNAMIC.....	P31 INTERFACE
ALL.....	TWINAX/COAX ID
010.003.004.135.....	IP RESOLUTION
255.255.255.000.....	IP PROTOCOL
010.003.004.001.....	IP ADDRESS
	SUBNET MASK
	DEFAULT GATEWAY

FIRMWARE IN THIS PRINTER IS COPYRIGHTED

Figure 33. Test Label



PAUSE Key Self Test

This self test can be used to provide the test labels required when making adjustments to the printer's mechanical assemblies; these test labels also ensure the printhead has been aligned correctly after it has been adjusted. See the sample printout in [Figure 34](#).

1. Turn off the printer (O).
2. Press and hold PAUSE while turning on the power (I).
 - The initial self test prints 15 labels at 2.4 in. or 61 mm per second, then automatically pauses the printer. When PAUSE is pressed, an additional 15 labels print.
 - While the printer is paused, pressing CANCEL alters the self test. When PAUSE is pressed, 15 labels print at 6 in. or 152 mm per second.
 - While the printer is paused, pressing CANCEL alters the self test a second time. When PAUSE is pressed, 50 labels print at 2.4 in. or 61 mm per second.
 - While the printer is paused, pressing CANCEL again alters the self test a third time. When PAUSE is pressed, 50 labels print at 6 in. or 152 mm per second.
 - While the printer is paused, pressing CANCEL again alters the self test a fourth time. When PAUSE is pressed, 15 labels print at the printer's maximum speed.
 - To exit this self test at any time, press and hold CANCEL.



Figure 34. PAUSE Key Test Label

FEED Key Self Test

See [Figure 35](#).

1. Turn off the printer (O).
2. Press and hold FEED while turning on the power (I).

The FEED Key Self Test prints out at various darkness settings above and below that of the darkness value shown on the configuration label ([Figure 33](#)). Examine these labels and determine which one has the best darkness setting for your application. This value can be entered into the printer by setting the darkness during the configuration procedure. Refer to [page 48](#) for more information.



Figure 35. FEED Key Test Label

The value printed on that label is added to (plus) or subtracted from (minus) the darkness value specified on the configuration label. The resulting numeric value (0 to 30) is the best darkness value for that specific media/ribbon combination.

FEED Key and PAUSE Key Self Test

1. Turn off the printer (O).
2. Press and hold FEED and PAUSE while turning on the power (I).

Performing this self test temporarily resets the printer configuration to the factory default values. These values are active only until power is turned off unless you save them permanently in memory.

Communications Diagnostics Test

This test is controlled from the front panel display. A typical printout from this test is shown in [Figure 36](#). Turn off the power to exit this self test.



NOTE: This label is inverted when printed.



Figure 36. Communications Test Label

Additional Printer Diagnostics

Additional diagnostic tests are available for this printer, however, they are beyond the scope of this users guide. Refer to the maintenance manual for information about these additional tests.



Specifications



NOTE: Printer specifications are subject to change without notice.

Media Handling

- **Tear-Off Mode:** Labels are produced in strips.
- **Peel-Off Mode:** Labels are dispensed and peeled from the liner as needed.
- **Cutter Mode:** Labels are printed and individually cut.
- **Rewind Mode:** Labels are rewound internally.

Options

• Printhead 300 dpi (12 dots/mm)	• PCMCIA Card Slot
• Cutter and catch tray*	• BAR-ONE Windows™-based WYSIWYG on-screen label design and print application software
• Rewind	• ZebraNet PrintServer II, including Ethernet interface (10Base-T), ZebraNet WebView graphical setup and printer control, and ZebraNet Alert unsolicited error notification
• Label peel and liner rewind	• ZebraNet Wireless Card Socket, and integrated wireless 802.11b Ethernet option that supports multiple third party LAN radio cards
• Internal fanfold media supply bin*	• IBM twinax or coax interface
• Font cards	

* Not compatible with rewind and peel options.

ZPL Programming Language (ZPL II)

<ul style="list-style-type: none"> Downloadable graphics, scalable and bitmap fonts, and label formats 	<ul style="list-style-type: none"> Status message to host upon request
<ul style="list-style-type: none"> Object copying between memory areas (RAM, memory card, and internal Flash) 	<ul style="list-style-type: none"> Programmable quantity with print, pause, and cut control
<ul style="list-style-type: none"> Code Page 850 character set 	<ul style="list-style-type: none"> Communicates in printable ASCII characters
<ul style="list-style-type: none"> Adjustable print cache 	<ul style="list-style-type: none"> Error-checking protocol
<ul style="list-style-type: none"> Data compression 	<ul style="list-style-type: none"> Controlled via mainframe, mini-computer, PC, portable data terminal
<ul style="list-style-type: none"> Automatic virtual input buffer management 	<ul style="list-style-type: none"> Serialized fields
<ul style="list-style-type: none"> Format inversion 	<ul style="list-style-type: none"> In-spec OCR-A and OCR-B
<ul style="list-style-type: none"> Mirror image printing 	<ul style="list-style-type: none"> UPC/EAN
<ul style="list-style-type: none"> Four-position field rotation (0°, 90°, 180°, 270°) 	<ul style="list-style-type: none"> User-programmable password
<ul style="list-style-type: none"> Slew command 	

Bar Codes

<ul style="list-style-type: none"> Bar code ratios (2:1 up to 3:1) 	<ul style="list-style-type: none"> Industrial 2 of 5 (supports ratios of 2:1 up to 3:1, Modulus 10 Check Digit)
<ul style="list-style-type: none"> Code 11 	<ul style="list-style-type: none"> Interleaved 2 of 5
<ul style="list-style-type: none"> Code 39 (supports ratios of 2:1 up to 3:1) 	<ul style="list-style-type: none"> LOGMARS
<ul style="list-style-type: none"> Code 93 	<ul style="list-style-type: none"> MSI
<ul style="list-style-type: none"> Code 128 (with subsets A, B, and C and UCC case codes) 	<ul style="list-style-type: none"> Codabar
<ul style="list-style-type: none"> ISBT-128 	<ul style="list-style-type: none"> Codablock (2-dimensional bar code)
<ul style="list-style-type: none"> UPC-A, UPC-E, UPC extensions 	<ul style="list-style-type: none"> PDF-417 (2-dimensional bar code)
<ul style="list-style-type: none"> EAN-8, EAN-13, EAN extensions 	<ul style="list-style-type: none"> Code 49 (2-dimensional bar code)
<ul style="list-style-type: none"> Plessey 	<ul style="list-style-type: none"> DataMatrix (2-dimensional bar code)
<ul style="list-style-type: none"> Postnet 	<ul style="list-style-type: none"> Maxi Code (2-dimensional bar code)
<ul style="list-style-type: none"> Standard 2 of 5 	<ul style="list-style-type: none"> QR Code (2-dimensional bar code)
<ul style="list-style-type: none"> Check digit calculation where applicable 	



General Specifications

General Specifications			105SL	
Height			15.5 in.	394 mm
Width			11.2 in.	284 mm
Depth			18.9 in.	480 mm
Weight (without options)			55 lb	25 kg
Electrical	General (auto-adjusting)		90–264 VAC; 48–62 Hz	
	Power Consumption	Printing PAUSE test label at slowest speed	180 W	
		Printer idle	19 W	
	Compliance		Complies with FCC class “B” and Canadian Doc. class “A” rules. Carries the CE mark of compliance.	
Temperature	Operating environment	Thermal transfer	40° to 104° F	5° to 40° C
		Direct thermal	40° to 104° F	5° to 40° C
	Storage	–40° to 140° F	–40° to 60° C	
Relative Humidity	Operating environment		20% to 85% non-condensing	
	Storage		5% to 85% non-condensing	

Printing Specifications

Printing Specifications		105SL	
Resolution		203 dots/inch (8 dots/mm)/ 300 dots/inch (12 dots/mm)	
Dot size (width × length)		0.0049 in. × 0.0049 in. (0.125 mm × 0.125 mm)/ 0.0033 in. × 0.0039 in. (0.084 mm × 0.10 mm)	
First dot location measured from inside media edge		0.10 in. ± 0.035 in. (2.5 mm ± 0.89 mm)	
Maximum print width		4.49 in. (114 mm)	
Print Length (maximum)	Continuous printing	203 dpi	90 in. (2286 mm)
		300 dpi	41 in. (1041 mm)
Media registration toleration* (non-continuous media)		Vertical	= ≤ ±0.050 in. (1.3 mm)
		Horizontal	= ≤ ±0.050 in. (1.3 mm)
Programmable print speeds		203 dpi	2.4 in. (61 mm) through 8.0 in. (203 mm) per second in 1 in. (25.4 mm) increments
		300 dpi	2.4 in. (61 mm) through 8.0 in. (203 mm) per second in 1 in. (25.4 mm) increments
Bar code modulus ("X") dimension	Ladder (rotated) orientation	203 dpi	4.9 mil to 49 mil
		300 dpi	3.9 mil to 39 mil
	Picket fence (nonrotated) orientation	203 dpi	4.9 mil to 49 mil
		300 dpi	3.3 mil to 33 mil
Thin film printhead with Element Energy Equalizer (E ³) [®]		Yes	

* Media registration and minimum label length are affected by media type and width, ribbon type, and print speed. Performance improves as these factors are optimized. Zebra recommends always qualifying any application with thorough testing.

Ribbon Specifications

Ribbon Specifications		105SL	
Ribbon must be wound with the coated side out.			
Ribbon width (<i>Zebra recommends using ribbon at least as wide as the media to protect the printhead from wear.</i>)	Minimum		0.79 in. (20 mm)
	Maximum		4.49 in. (114 mm)
Standard lengths	2:1 media to ribbon roll ratio		984 ft. (300 m)
	3:1 media to ribbon roll ratio		1476 ft. (450 m)
Ribbon core inside diameter			1.0 in. (25.4 mm)
Maximum ribbon roll outside diameter			3.2 in. (81.3 mm)



Font Specifications

203 dpi (8 dots/mm)				
Fonts	Matrix (in dots) (H × W)	Type*	Minimum Char. Size (H × W)	Maximum C.P.I.
A	9 × 5	U-L-D	0.044 in. × 0.029 in.	33.9
B	11 × 7	U	0.054 in. × 0.044 in.	22.6
C,D	18 × 10	U-L-D	0.088 in. × 0.059 in.	16.9
E	28 × 15	OCR-B	0.138 in. × 0.098 in.	10.1
F	26 × 13	U-L-D	0.128 in. × 0.079 in.	12.7
G	60 × 40	U-L-D	0.295 in. × 0.236 in.	4.2
H	21 × 13	OCR-A	0.103 in. × 0.093 in.	10.7
GS	24 × 24	SYMBOL	0.118 in. × 0.118 in.	8.4
∅	variable	U-L-D	variable	N/A

300 dpi (12 dots/mm)				
Fonts	Matrix (in dots) (H × W)	Type*	Minimum Char. Size (H × W)	Maximum C.P.I.
A	9 × 5	U-L-D	0.030 in. × 0.020 in.	50.0
B	11 × 7	U	0.037 in. × 0.030 in.	33.3
C,D	18 × 10	U-L-D	0.060 in. × 0.040 in.	25.0
E	41 × 20	OCR-B	0.137 in. × 0.087 in.	11.5
F	26 × 13	U-L-D	0.087 in. × 0.052 in.	18.8
G	60 × 40	U-L-D	0.200 in. × 0.160 in.	6.3
H	30 × 19	OCR-A	0.100 in. × 0.093 in.	10.7
GS	24 × 24	SYMBOL	0.080 in. × 0.080 in.	12.5
∅	variable	U-L-D	variable	N/A

* U = Uppercase; L = Lowercase; D = Descenders

- Bitmap fonts A through H and GS symbols are expandable up to 10 times, height and width independent.
- Smooth scalable font ∅ (CG Triumvirate™ Bold Condensed) is expandable dot-by-dot, height and width independent.
- IBM® Code Page 850 International Characters.

Media Specifications

Media Specifications		105SL	
Minimum label length*	Tear-Off	0.7 in. (18 mm)	
	Peel-Off	0.5 in. (13 mm)	
	Cutter	1.5 in. (38 mm)	
	Rewind	0.25 in. (6 mm)	
Total media width (label + liner, if any)	Minimum	0.79 in. (20 mm)	
	Maximum	4.52 in. (115 mm)	
Total thickness (includes liner, if any)	Minimum	0.003 in. (0.076 mm)	
	Maximum	0.012 in. (0.305 mm)	
Cutter maximum full-width media thickness		0.009 in. (0.229 mm)	
Roll media core inside diameter		3 in. (76 mm)	
Maximum roll diameter		8.0 in. (203 mm)	
Inter-label gap	Minimum	0.079 in. (2 mm)	
	Preferred	0.118 in. (3 mm)	
	Maximum	Maximum inter-label gap = 2 × (label length for which you have calibrated the printer) + 1 in. or 25.4mm.	
Maximum internal fanfold media pack size (label + liner) L × W × H		8.0 in. × 4.5 in. × 4.5 in. (203 mm × 114 mm × 114 mm)	
Ticket/tag sensing notch L × W		0.12 in. × 0.25 in. (3 mm) × (6 mm)	
Ticket/tag sensing hole diameter		0.125 in. (3 mm)	
Additional specifications for black mark sensing	Mark length (measuring parallel to label/tag edge)	Minimum	0.12 in. (3 mm)
		Maximum	0.43 in. (11 mm)
	Mark width (measuring to perpendicular label/ tag edge)	Minimum	≥ 0.43 in. (≥ 11 mm)
		Maximum	Full media width
	Mark location		Marks must be located within 0.040 in. (1 mm) of the inside media edge.
	Mark density		>1.0 Optical Density Unit (ODU)
Maximum density of back of media on which black mark is printed		0.5 ODU	

* Media registration and minimum label length are affected by media type and width, ribbon type, print speed, and printer mode of operation. Performance improves as these factors are optimized. Zebra recommends always qualifying any application with thorough testing.



Power Cord Specifications

- The overall length must be less than 9.8 feet (3.0 meters).
- It must be rated for at least 5 A, 250 V.
- The chassis ground (earth) **must** be connected to ensure safety and reduce electromagnetic interference. The ground connection is handled by the third wire (earth) in the power cord. See [Figure 37](#).
- The AC power plug and IEC 320 connector must bear the certification mark of at least one of the known international safety organizations shown in [Figure 38](#).

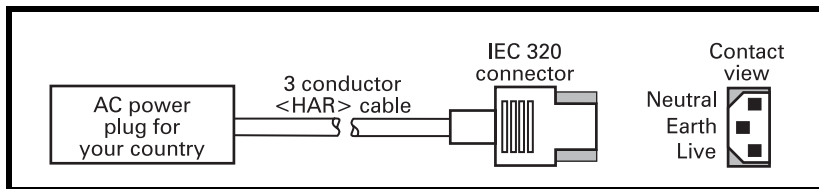

Figure 37. Power Cord

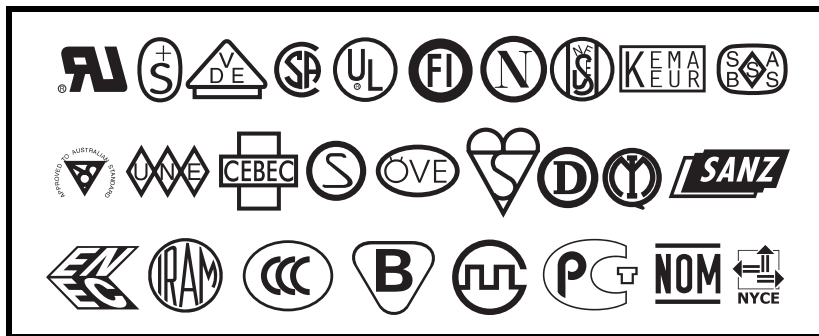

Figure 38. International Safety Organization Symbols



Appendix A: DB-25 Connectors

Printer Interface Technical Information

RS-232/RS-422/RS-485 Serial Data Port

The connections for these standard interfaces are made through the DB-25S connector on the rear panel. For all RS-232 input and output signals, the printer follows both the Electronics Industries Association's (EIA) RS-232 specifications and the Consultative Committee for International Telegraph and Telephone (CCITT) V.24 standard signal level specifications.

Table A-1 shows the pin configuration and function of the rear panel serial data connector on the printer.

Table A-1. Serial Port Pin Configuration

Pin No.	Description
1	FG (frame ground) for cable shield
2	TXD (RS-232 transmit data) output from printer
3	RXD (RS-232 receive data) input to printer
4	RTS (RS-232 request to send) output from printer
6	DSR (data set ready) input to printer
7	SG (signal ground) for RS-232
9	+5 VDC source output (1 Amp maximum)
11	SGR (signal ground reference) for RS-422/RS-485
13	Data input B (-); RS-422/RS-485
14	Data output B (-); RS-422/RS-485
16	Data input A (+); RS-422/RS-485
19	Data output A (+); RS-422/RS-485
20	DTR (RS-232 data terminal ready) output from printer
	NOTE: Pins 5, 8, 10, 12, 15, 17, 18, 21–25 are unused and unterminated.

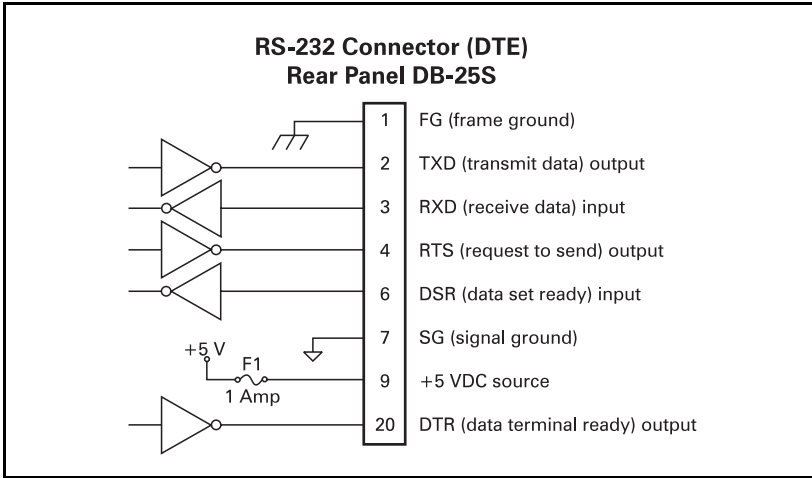

Figure 39. RS-232 Connections

RS-232 Interconnections

The printer is configured as Data Terminal Equipment (DTE).

Figure 39 illustrates the internal connections of the printer’s RS-232 connector.

Figure 40 illustrates the connections required to interconnect the printer with the standard 9-pin serial port connector on a computer.



NOTES: If using a 9-pin to 25-pin adapter plug attached to the computer, use a null modem cable between the adapter plug and the printer.

To connect the printer to other DTE devices with DB-25 connectors (such as the serial port of a PC), an RS-232 null modem (crossover) cable should be used.

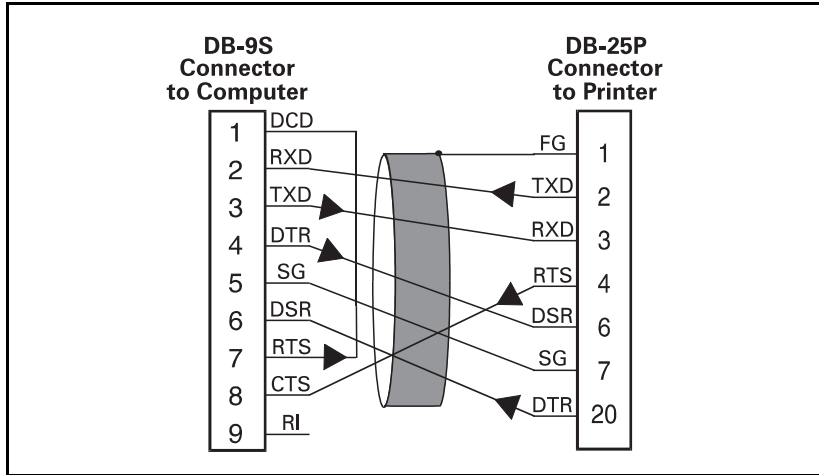

Figure 40. 9-Pin Serial Port Connections

When the printer is connected via its RS-232 interface to Data Communication Equipment (DCE), such as a modem, use a standard RS-232 (straight-through) interface cable. [Figure 41](#) illustrates the connections required for this cable.

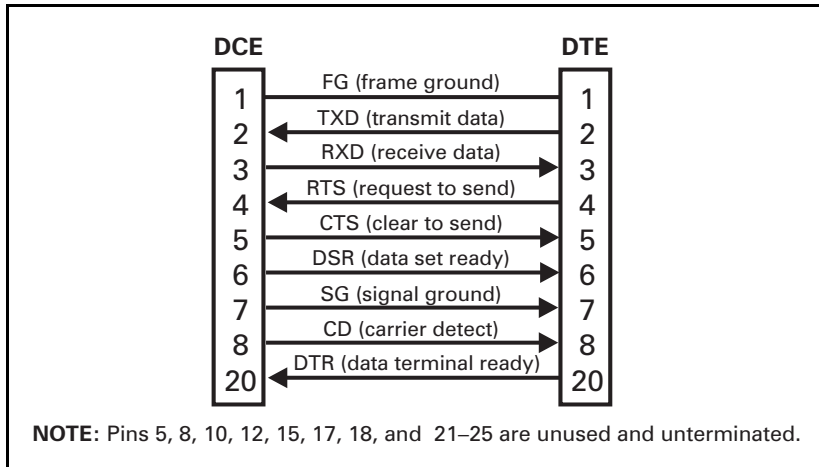

Figure 41. RS-232 Cable Connections

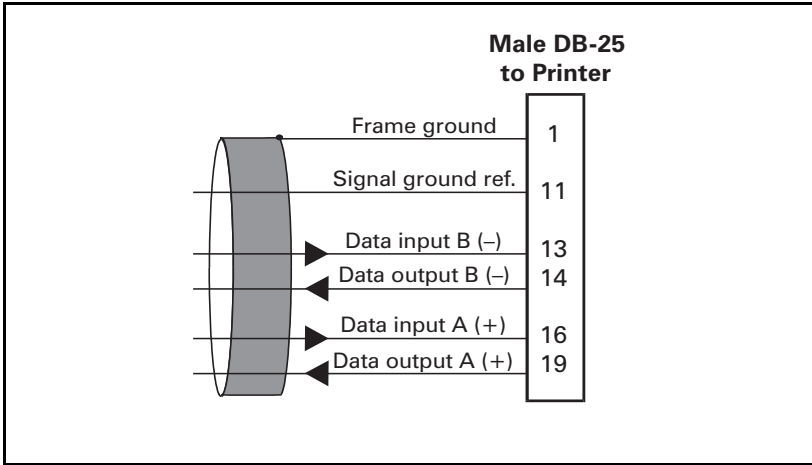

Figure 42. DB-25 RS-422/RS-485 Connections

RS-422/RS-485 Interconnections

The printer may be connected to a host computer by either an RS-422 or an RS-485 interface. The DB-25 connector on the rear of the printer uses specific pins for this purpose. Figure 42 illustrates the required cable wiring for interconnecting to the printer's DB-25 connector. Figure 43 illustrates the internal connections of the printer's RS-422 or RS-485 connector.

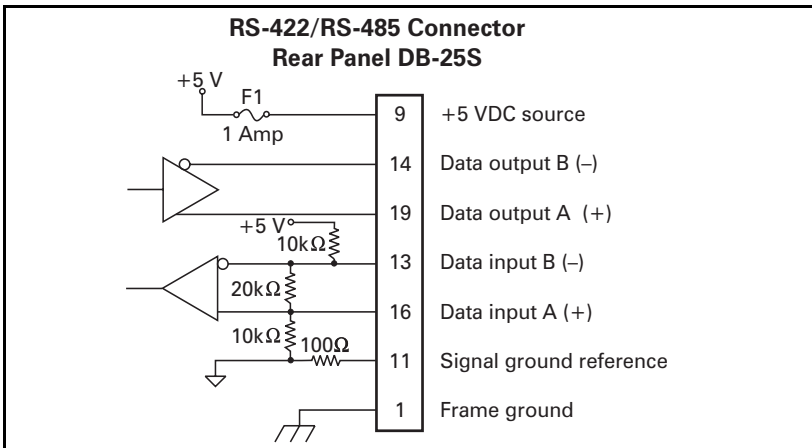

Figure 43. RS-422/RS-485 Connections



Parallel Data Port

A standard 36-pin parallel connector is available at the rear of the printer for connection to the data source. Under normal circumstances, data sent from the printer to the host computer in response to a “Printer Status Request” command is sent through the RS-232 serial port. However, if the host computer has a properly configured IEEE-1284 parallel port that is recognized by the printer, status information is returned through the parallel port. Port selection for status information is determined each time the printer is turned on.

Parallel Port Interconnections

Table A-2 shows the pin configuration and function of a standard computer-to-printer parallel cable.

Table A-2. Parallel Port Pin Configuration

36-pin Connector	Description
1	nStrobe/HostClk
2–9	Data Bits 1–8
10	nACK/PtrClk
11	Busy/PtrBusy
12	PError/ACKDataReq
13	Select/Xflag
14	nAutoFd/HostBusy
15	Not used
16 & 17	Ground
18	+5 V @ 1 A
19–30	Ground
31	ninit
32	nFault/NDataAvail
33 & 34	Not used
35	+5 V through a 4.7 KW Resistor
36	Nselectin/1284 active



Appendix B: DB-9 Connectors

Printer Interface Technical Information

RS-232 Serial Data Port

The connection for this standard interface is made through the female DB-9 connector on the rear panel. A DB-9 to DB-25 interface module is required for all RS-232 connections through a DB-25 cable (see [page 104](#) for details).

For all RS-232 input and output signals, the printer follows both the Electronics Industries Association's (EIA) RS-232 specifications and the Consultative Committee for International Telegraph and Telephone (CCITT) V.24 standard signal level specifications.

Table B-1 shows the pin configuration and function of the rear panel serial data connector on the printer.

Table B-1. Serial Port Pin Configuration

Pin No.	Name	Description
1	—	Not connected
2	RXD	Receive data—data input to printer
3	TXD	Transmit data—data output from printer
4	DTR	Data terminal ready—output from printer
5	SG	Signal ground
6	DSR	Data set ready—input to printer
7	RTS	Request to send—output from printer
8	CTS	Clear to send—input to printer
9	+5 V DC	+5 VDC signal output NOTE: This pin is also available as a +5 VDC power source at 750 mA. To enable this capability, a jumper on the computer's main logic board needs to be installed on JP1, pins 2 and 3.



NOTE: An interface module is required for RS-422/RS-485 interface support (see [page 105](#)).

RS-232 Interface Connections

The printer is configured as Data Terminal Equipment (DTE). [Figure 44](#) illustrates the internal connections of the printer's RS-232 connector.

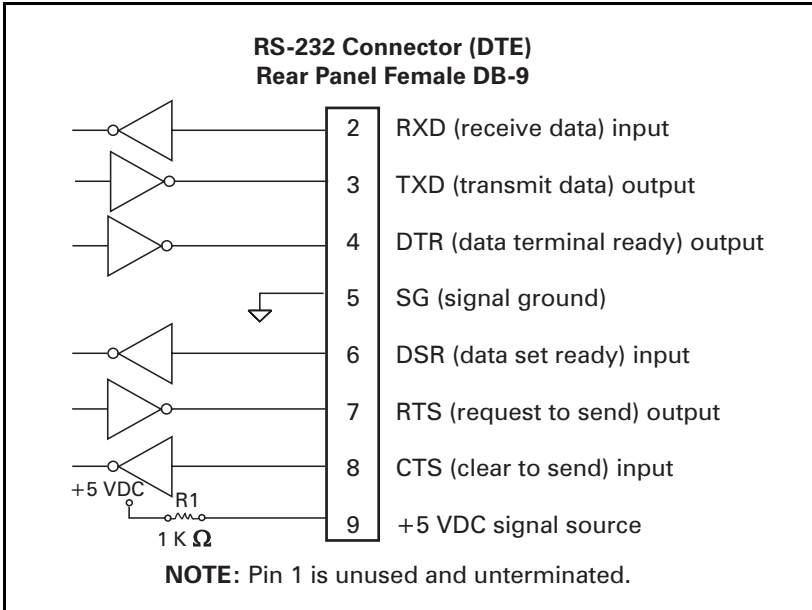

Figure 44. RS-232 Connections



NOTE: The cable used to connect the printer to a computer must be a null modem (crossover) cable. If you want to connect the printer to any other DTE devices, a null modem cable must also be used.



When the printer is connected via its RS-232 interface to Data Communication Equipment (DCE) such as a modem, use a standard RS-232 (straight-through) interface cable. Figure 45 illustrates the connections required for this cable.

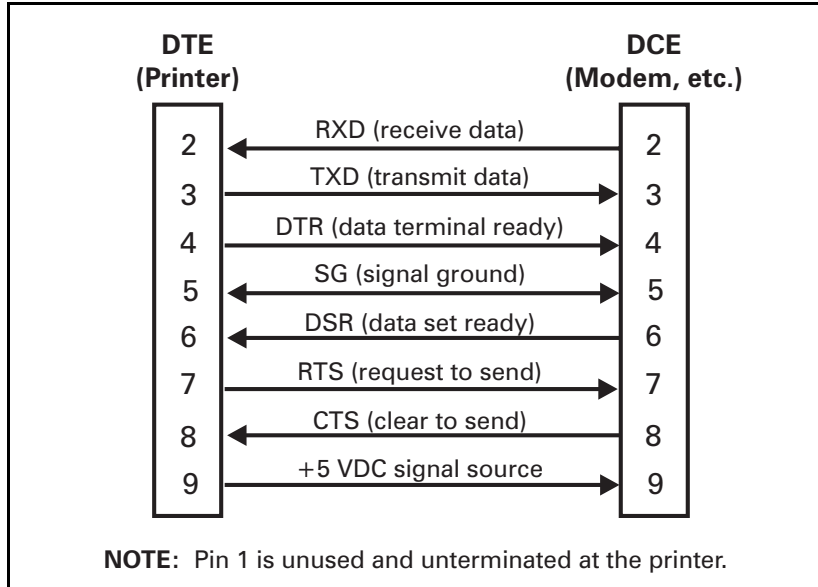

Figure 45. RS-232 Cable Connections

RS-232 Interconnections Using a DB-25 Cable

To connect the printer's RS-232 DB-9 interface to a DB-25 connector, an interface adapter is required (part number 3138). A generic DB-25 adapter may also be used, however, the +5 VDC signal source would not be passed through. [Figure 46](#) illustrates the connections required for the DB-9 to DB-25 interface.



NOTE: The cable used to connect the printer to a computer must be a null modem (crossover) cable. If you want to connect the printer to any other DTE devices, you must also use a null modem cable.

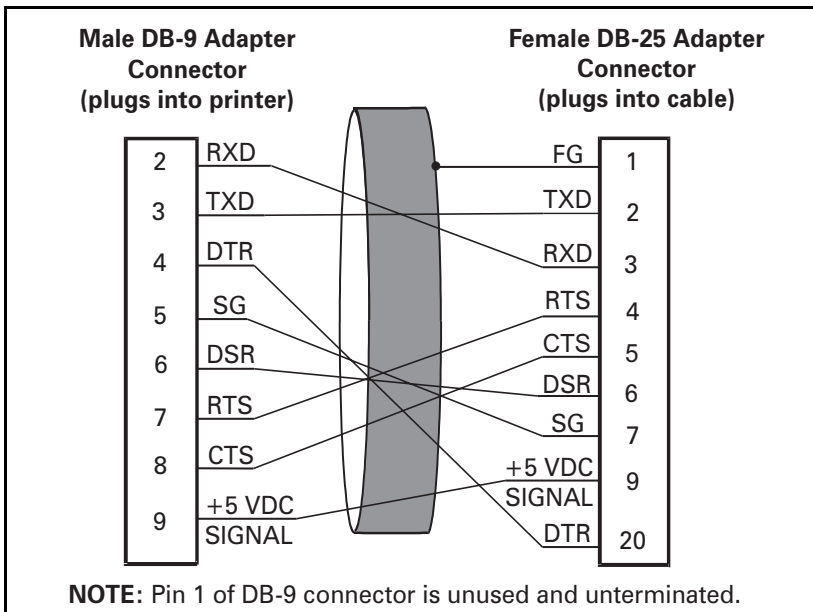

Figure 46. DB-9 to DB-25 Connections



RS-422/RS-485 Interconnections



NOTE: A jumper on the computer's main logic board needs to be installed on JP1, Pins 2 and 3, for the RS-422/RS-485 interface adapter to function properly.

To connect the printer's RS-232 DB-9 interface to a host computer through an RS-422 or an RS-485 interface, an interface adapter is required (part number 33130). [Figure 47](#) illustrates the required cable wiring for interconnecting to the interface adapter's DB-25 female connector.

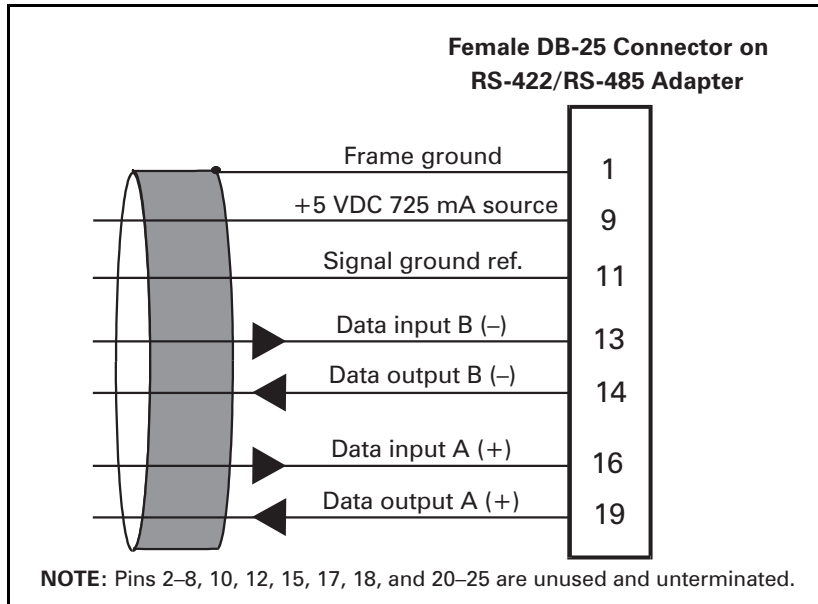

Figure 47. DB-25 Adapter Connections

Parallel Data Port

A standard 36-pin parallel connector is available at the rear of the printer for connection to the data source. Under normal circumstances, data sent from the printer to the host computer in response to a “Printer Status Request” command is sent through the RS-232 serial port. However, if the host computer has a properly configured IEEE-1284 parallel port that is recognized by the printer, status information is returned through the parallel port. Port selection for status information is determined each time the printer is turned on.

Parallel Port Interconnections

Table B-2 shows the pin configuration and function of a standard computer-to-printer parallel cable.

Table B-2. Parallel Port Pin Configuration

36-pin Connector	Description
1	nStrobe/HostClk
2–9	Data Bits 1–8
10	nACK/PtrClk
11	Busy/PtrBusy
12	PError/ACKDataReq
13	Select/Xflag
14	nAutoFd/HostBusy
15	Not used
16 & 17	Ground
18	+5 V @ 750 mA
19–30	Ground
31	ninit
32	nFault/NDataAvail
33 & 34	Not used
35	+5 V through a 1.8K Ω Resistor
36	NSelectin/1284 active

Appendix C: PCMCIA Card

PCMCIA Card Installation

The PCMCIA card slot is a factory-installed option. If your printer has this option, you may install or change the card at any time. Use the following procedure to install a PCMCIA card.



CAUTION: Observe proper electrostatic safety precautions when handling any static-sensitive components such as printed circuit boards and printheads.

1. Place the POWER switch in the “off” position (O) and disconnect the power cord. Disconnect the data cables.
2. Refer to [Figure 48](#). Remove and retain the screw and the option card shield from the rear of the printer.
3. If you are replacing the card, press the card-eject button and slide the card out of the slot.
4. Slide the new card into the slot far enough so that the eject button pops out.
5. Reinstall the option card shield and secure it with the screw.
6. Reconnect the power cord and all data cables.
7. Press and hold **FEED** while placing the power switch in the “on” position (I).
8. Verify the presence of additional memory or optional fonts by checking the information on the configuration label that was printed during the power-on sequence.
9. The printer is now ready to operate with the additional memory or font option.

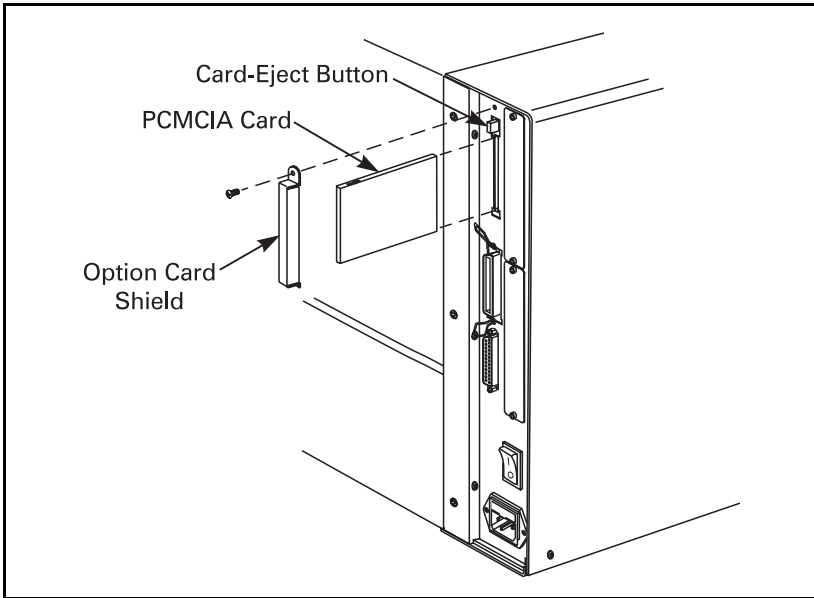

Figure 48. PCMCIA Card Installation

Appendix D: Save-a-Printhead Cleaning Film

Extend the Life of Your Printhead with Save-a-Printhead Cleaning Film

Recommended for all Zebra printers“ especially 600 dpi printers

Challenge

The printhead is the most critical component in your printer, and possibly the most delicate. It is a consumable item, just like the brakes on your car, that eventually wears over time. However, with ongoing careful attention and maintenance, you can **extend the life of the printhead**.

Below are photographs of three printheads. The first printhead is brand new. The second has printed over 1 million linear inches of thermal transfer labels and has been properly maintained. The third printhead has printed far fewer labels, but without proper care and maintenance, signs of abrasion and contamination buildup are evident.

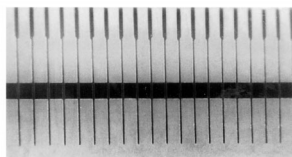

New

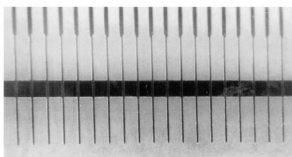

Over 1 Million Inches
(Properly Maintained)

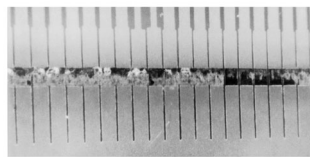

Less Than 1 Million Inches
(Without Proper Care)

Preventive Maintenance

For optimum performance, clean the printhead regularly. Take care when handling or cleaning the printhead by removing any jewelry that may scratch it, and use a grounding strap or anti-static mat to discharge static electricity that could damage the printhead.

For 200 and 300 dpi printers: Clean after every roll (1500 feet or 450 m) of thermal transfer ribbon or after every roll (500 feet or 150 m) of direct thermal labels or when CLEAN HEAD NOW appears on the liquid crystal display (LCD).

For 600 dpi printers: Clean after every roll (500 feet or 150 m) of labels (direct or thermal transfer) or when CLEAN HEAD NOW appears on the liquid crystal display (LCD).

To start, use only the presoaked (isopropyl alcohol) cleaning swabs provided in the preventive maintenance kit (part number 47362). Open the media cover to access the printhead, then open the printhead. Lightly blow or brush away any loose dust and lint particles within the print mechanism (such as rollers, media or ribbon sensors, and printhead). **Never** use any hard, metallic, or abrasive objects—such as a screwdriver—to remove adhesives or other contaminants that may have built up on the printhead. Next, press the swab tip against the printhead and swipe the print elements from end to end. Finally, turn the platen rollers while wiping them from side to side. Repeat this last step until the swab no longer shows dirt.

Avoid the Contributing Factors to Premature Printhead Failure

Abrasion: Over time, the movement of media and ribbon across the printhead wears through the protective ceramic coating, exposing and eventually damaging the print elements (dots).

To avoid abrasion:

- Clean your printhead frequently and use well-lubricated thermal transfer ribbons with backcoatings optimized to reduce friction.
- Minimize printhead pressure and burn temperature settings by optimizing the balance between the two.
- Ensure that the thermal transfer ribbon is as wide as or wider than the label media to prevent exposing the elements to the more abrasive label material.



Ribbon Backcoating and Buildup: Printhead contamination from direct thermal labels or thermal transfer ribbon may occur in applications requiring high burn settings, high head pressure, high speed, or high volume. This contamination builds up on the printhead elements, creating a barrier to the heat transformation required to produce high-quality images. Contaminant buildup occurs gradually and results in poor print quality that may look like faded print or a failed print element. This buildup resists cleaning with presoaked swabs and can be difficult to remove. Follow the recommendations below to avoid contamination buildup on the printhead.

To avoid ribbon backcoating and buildup:

- Use thermal transfer ribbons that have been specially cured to provide backcoat protection for high-demand applications. These ribbons (sometimes referred to as anti-stick ribbons) also dissipate static and provide more lubrication.
- Follow the recommended Printhead Preventive Maintenance procedures.
- Use Zebra's *Save-a-Printhead* cleaning film to remove printhead contamination buildup quickly and easily.

***Save-a-Printhead* Cleaning Film**

Save-a-Printhead cleaning film is a specially coated film that removes contamination buildup without damaging the printhead. *Save-a-Printhead* cleaning film extends the life of your printhead, reduces maintenance downtime and the cost of replacing a printhead, and is an inexpensive, easy, and quick way to remove contaminants without removing the printhead.

Use *Save-a-Printhead* cleaning film when you see degrading print quality that looks like faded print or a failed print element that cannot be corrected by cleaning with the presoaked cleaning swabs.

For 200 and 300 dpi printers: Clean after every roll (1500 feet or 450 m) of thermal transfer ribbon or after every roll (500 feet or 150 m) of direct thermal labels or when CLEAN HEAD NOW appears on the liquid crystal display (LCD).

For 600 dpi printers: Clean after every roll (500 feet or 150 m) of labels (direct or thermal transfer) or when CLEAN HEAD NOW appears on the liquid crystal display (LCD).

How to Use *Save-a-Printhead* Cleaning Film



NOTE: If power is removed from an *XiIIIPlus* printer when cleaning printhead, CLEAN HEAD NOW does not disappear.



CAUTION: An improperly seated printhead data cable or power cable could result in the printhead generating excessive heat that could cause harm if it is touched.

1. Open the media cover.
2. Open the printhead, remove labels and ribbon from the print mechanism.
3. Clean the printhead per recommended preventive maintenance procedures.
4. Position the *Save-a-Printhead* film in the print path, placing the glossy side down away from the printhead (matte side up).
5. Close and latch the printhead.
6. Slowly pull the full length of the film through the print mechanism.
7. Clean the printhead a second time per recommended preventive maintenance procedures.
8. Reload labels and ribbon, close and latch the printhead.
9. Close the media cover.



10. Print labels and inspect for improved print quality. If quality has not improved, contact Zebra's Technical Support staff at **1.847.913.2259** or visit our Web site: www.zebra.com.

Only one pass of *Save-a-Printhead* film is required to remove contamination buildup, and each strip of film can be used up to 10 times. Discard the strip when residue buildup or other contamination is apparent.

If a replacement printhead is needed, Zebra strongly recommends using a product from the Original Equipment Manufacturer (OEM) to ensure that your printer and part warranties remain intact and that the product performs optimally.

How to Order Save-a-Printhead Cleaning Film Kits

There are five kits to accommodate printers with different print widths. Each kit contains three 10 in. (254 mm) long strips of film. Reference the following table to order the appropriate kit for your printer:

Order kit number:	For Printers with Print Widths of:
46902	3.0 in.–4.0 in. (76 mm–102 mm)
44902	4.0 in.–5.0 in. (102 mm–127 mm)
48902	5.0 in.–6.0 in. (127 mm–152 mm)
38902	6.0 in.–7.0 in. (152 mm–178 mm)
22902	8.0 in.–9.0 in. (178 mm–229 mm)





Index

A

- adjustments
 - lower media sensor, 12
 - printhead pressure, 73
 - toggle positioning, 72
 - upper media sensor, 11

B

- backfeed setting, 59
- bar codes specifications, 88
- baud setting, 54
- black mark sensor positioning, 12

C

- cabling requirements, 23
- calibration, 5–20
- CANCEL key self test, 82
- Cleaning
 - Save-a-Printhead Film, 109–113
- cleaning
 - cutter, 70
 - exterior, 66
 - interior, 66
 - printhead and platen roller, 66
 - schedule, 65
 - sensors, 68
 - snap plate, 68
- communications
 - diagnostics test, 85
 - setting, 56
- configuration
 - calibration sequence, 48–63
 - changing passwords, 46
 - entering the setup mode, 45
 - leaving the setup mode, 47
 - software or printer driver, 16
- continuous media, 7
- control prefix setting, 57
- cutter jammed warning, 77
- cutter mode loading, 35

D

- damage, 2
- darkness setting, 48
- data bits setting, 54
- data ports
 - parallel, 99, 106
 - serial, 95–98, 101–105
- DB-25 serial interface connector, 21
- DB-9 serial interface connector, 21
- default gateway setting, 62
- delimiter character setting, 57

F

- fanfold media loading, 39
- FEED key and PAUSE key self test, 85
- FEED key self test, 84
- font card installation, 107
- font specifications, 91
- format convert setting, 61
- format prefix setting, 57
- front panel
 - display, 26
 - keys, 27
 - lights, 28
 - overview, 14
- fuse replacement, 71

G

- general specifications, 89

H

- head close setting, 58
- head cold warning, 76
- head open error, 76
- head resistor setting, 60
- head too hot warning, 76
- host handshaking setting, 55

I

- inspection, 2
- interconnections
 - RS-232, 96, 102–104
 - RS-422, 98, 105
 - RS-485, 98, 105
- interface connectors
 - DB-25, 21
 - DB-9, 21
- IP settings
 - address, 62
 - protocols, 62
 - resolution, 62

L

- label liner removal, 38
- label top setting, 59
- language setting, 63
- LCD adjustment setting, 61
- left position setting, 59
- list settings
 - all, 51
 - bar codes, 51
 - fonts, 51
 - formats, 51
 - images, 51
 - setup, 51
- loading
 - media, 9, 29–37
 - ribbon, 13
- lower media sensor adjustment, 12
- lubrication, 70

M

- maximum length setting, 50
- media and ribbon
 - calibration procedure, 17
 - calibration setting, 53
 - requirements, 3
- media handling specifications, 87

- media loading
 - cutter mode, 35
 - peel-off mode, 31
 - peel-only mode, 36
 - rewind mode, 33
 - tear-off mode, 29
- media power-up setting, 58
- media sensors positioning
 - black mark sensor, 12
 - transmissive sensor, 10
- media specifications, 92
- media types
 - continuous media, 7
 - non-continuous black mark media, 7
 - non-continuous web media, 6
 - setting, 49
- memory card installation, 107

N

- network ID setting, 56
- non-continuous black mark media, 7
- non-continuous web media, 6

O

- operator controls, 25–28
- options, 87
- out of memory error, 77

P

- paper out error, 75
- parallel communication setting, 54
- parallel data port, 23, 99, 106
- parity setting, 55
- passwords, 46
- PAUSE key self test, 83
- PCMCIA card installation, 107
- peel-off mode loading, 31
- peel-only mode loading, 36
- power cord
 - connection, 3
 - specifications, 93
- POWER switch, 14, 25
- power-on self test, 81
- print method setting, 49



- print mode
 - cutter, 8
 - peel-off, 8
 - rewind, 8
 - setting, 48
 - tear-off, 8
- print test label, 19
- print width setting, 50
- printer
 - anatomy overview, 4
 - configuration, 15
 - diagnostics, 81
- printhead pressure adjustment, 73
- printing specifications, 90
- protocol setting, 55

R

- rewind mode loading, 33
- ribbon
 - error (ribbon out), 75
 - loading, 13, 41
 - removal, 43
 - specifications, 90
 - warning (ribbon in), 76
- RS-232 serial data port, 95, 101
- RS-422 serial data port, 95
- RS-485 serial data port, 95

S

- Save-a-Printhead Cleaning Film, ??–113
- self tests
 - additional printer self tests, 81
 - CANCEL key, 82
 - communications diagnostics test, 85
 - FEED key and PAUSE key, 85
 - FEED key, 84
 - PAUSE key, 83
 - power-on, 81
- sensor profile setting, 52
- sensor type setting, 49
- serial communication setting, 54
- serial data port, 95–98, 101–105
- serial interface connector
 - DB-25, 21
 - DB-9, 21

- setup mode
 - entering, 45
- specifications
 - bar codes, 88
 - font, 91
 - general, 89
 - media handling, 87
 - media, 92
 - options, 87
 - power cord, 93
 - printing, 90
 - ribbon, 90
 - ZPL, 88
- stop bits setting, 55
- storage, 2
- subnet mask setting, 62
- system interfaces, 21

T

- tear-off mode loading, 29
- tear-off setting, 48
- test label printing, 19
- toggle positioning, 72
- transmissive sensor positioning, 10
- troubleshooting
 - communications, 79
 - LED error conditions and warnings, 75
 - print quality problems, 77
 - wrinkled ribbon, 79

U

- unpacking, 2
- upper media sensor adjustment, 11

Z

- ZPL mode setting, 58
- ZPL specifications, 88





Printer Software and Firmware License Agreement

YOU SHOULD CAREFULLY READ THE FOLLOWING TERMS AND CONDITIONS OF THIS ZEBRA TECHNOLOGIES PRINTER SOFTWARE AND FIRMWARE LICENSE AGREEMENT (“PSFLA”) BEFORE USING THE PRINTER WHICH IS ENCLOSED OR OTHERWISE ASSOCIATED WITH THIS AGREEMENT. IF YOU DO NOT AGREE WITH THESE TERMS AND CONDITIONS, DO NOT OPERATE THE PRINTER AND PLEASE PROMPTLY RETURN THE PRINTER, ENCLOSURES AND ALL PACKAGING FOR A FULL REFUND.

Zebra Technologies (“ZEBRA”) hereby grants you a non-exclusive, non-transferable license to use the SOFTWARE and FIRMWARE embedded in the printer and the accompanying documentation according to the following terms:

1. The printer enclosed with or otherwise associated with this Agreement has or includes certain SOFTWARE and FIRMWARE therein which is protected by copyright laws and international copyright treaties, as well as other intellectual property laws and treaties. The SOFTWARE and FIRMWARE is licensed, not sold. Such SOFTWARE and/or FIRMWARE may include, but is not limited to, SOFTWARE and/or FIRMWARE that is licensed under one or more of the following trademarks: ZPL (Zebra Programming Language), ZebraLink, Web View, Web Alert, ZBI (Zebra BASIC Interpreter), BAR-ONE, ZTools, Utilities, ZebraNet View for IP, ZebraNet Alert, PC Management Program, ZebraNet View for Networks, and ZebraNet Connect.
2. GRANT OF LICENSE. This License grants you the following rights:
 - SOFTWARE and FIRMWARE. You may use, access, display, run, or otherwise interact with (“RUN”) the SOFTWARE and FIRMWARE in connection with operating the printer which is enclosed with or otherwise associated with this PSFLA (“PRINTER”). The primary user of the PRINTER may make a second copy for his or her exclusive use on a portable computer/printer.
 - Storage/Network Use. You may also store or install a copy of the SOFTWARE and FIRMWARE on a storage device, such as a network server, used only to RUN the SOFTWARE and FIRMWARE on your other PRINTERS over an internal network; however, you must acquire and dedicate a license for each separate PRINTER on which the SOFTWARE and FIRMWARE is RUN from the storage device. A license for the SOFTWARE and FIRMWARE may not be shared or used concurrently on different PRINTERS.



- Reservation of Rights. All rights not expressly granted are reserved by ZEBRA.
- Accessing Services Using the SOFTWARE and FIRMWARE. Your use of any service accessible using the SOFTWARE and FIRMWARE is not covered by this PSFLA and may be governed by separate terms of use, conditions or notices.

3. RESTRICTIONS.

- You must maintain all copyright notices on all copies of the SOFTWARE and FIRMWARE.
- Limitations on modification. You may not modify, adapt, translate, or create derivative works based on this SOFTWARE OR FIRMWARE or the accompanying documentation.
- Limitations of Reverse Engineering, Decompilation and Disassembly. You may not reverse engineer, decompile, or disassemble the SOFTWARE or the FIRMWARE, except and only to the extent that such activity is permitted by applicable law notwithstanding this limitation.
- Rental. You may not rent or lease or lend the SOFTWARE or FIRMWARE.
- Support Services. ZEBRA may provide you with support services related to the SOFTWARE and/or FIRMWARE (“SUPPORT SERVICES”), in its discretion. Use of SUPPORT SERVICES, if any, is governed by the ZEBRA policies and programs described in the user manual, in “online” documentation, and/or other ZEBRA provided materials. Any supplemental SOFTWARE or FIRMWARE code provided to you as a part of SUPPORT SERVICES shall be considered part of the SOFTWARE and/or FIRMWARE and is subject to the terms of this PSFLA. With respect to technical information you provide to ZEBRA as part of the SUPPORT SERVICES, ZEBRA may use such information for its business purposes, including for product support and development. ZEBRA will not utilize such technical information in a form that personally identifies you except to the extent necessary to provide you with support.
- Replacement, Modification and Upgrade of the SOFTWARE and/or FIRMWARE. ZEBRA reserves the right to replace, modify or upgrade the SOFTWARE and/or FIRMWARE at any time by offering you a replacement or modified version of the SOFTWARE and/or FIRMWARE or such upgrade and to charge for such replacement, modification or upgrade. Any such replacement or modified SOFTWARE and/or FIRMWARE code or upgrade to the SOFTWARE and/or FIRMWARE offered to you by ZEBRA shall be considered part of the SOFTWARE and/or FIRMWARE and subject to the terms of this PSFLA (unless this PSFLA is superseded by a further PSFLA accompanying such replacement or modified version of or upgrade to the SOFTWARE and/or FIRMWARE). In the event that ZEBRA offers a replacement or modified version of or any upgrade to the SOFTWARE and/or FIRMWARE, (a) your continued use of the SOFTWARE and/or FIRMWARE is conditioned on your acceptance of such replacement or modified version of or upgrade to the SOFTWARE and/or FIRMWARE and any accompanying superseding PSFLA and (b) in the case of the replacement or modified SOFTWARE and/or FIRMWARE, your use of all prior versions of the SOFTWARE and/or FIRMWARE is terminated.

4. **TERMINATION.** Without prejudice to any other rights, ZEBRA may terminate this PSFLA if you fail to comply with the terms and conditions of this PSFLA. ZEBRA may terminate this PSFLA by offering you a superseding PSFLA for the SOFTWARE and/or FIRMWARE or any replacement or modified version of or upgrade to the SOFTWARE and/or FIRMWARE and conditioning your continued use of the SOFTWARE and/or FIRMWARE or such replacement, modified or upgraded version on your acceptance of such superseding PSFLA. In addition, ZEBRA may terminate this PSFLA by notifying you that your continued use of the SOFTWARE and/or



FIRMWARE is prohibited. In the event that ZEBRA terminates this PSFLA, you must immediately stop using the SOFTWARE and/or FIRMWARE and destroy all copies of the SOFTWARE and/or FIRMWARE and all of its component parts.

5. **COPYRIGHT.** All title and copyrights in and to the SOFTWARE and FIRMWARE, the accompanying printed materials, and any copies of the SOFTWARE and FIRMWARE, are owned by ZEBRA or its suppliers. All title and intellectual property rights in and to the content which may be accessed through use of the SOFTWARE and/or FIRMWARE is the property of the respective content owner and may be protected by applicable copyright or other intellectual property laws and treaties. This PSFLA grants you no rights to use such content. If this SOFTWARE and/or FIRMWARE contains documentation which is provided only in electronic form, you may print one copy of such electronic documentation. You may not copy the printed materials accompanying the SOFTWARE and/or FIRMWARE.
6. **U.S. GOVERNMENT RESTRICTED RIGHTS.** All SOFTWARE and/or FIRMWARE provided to the U.S. Government pursuant to solicitations issued on or after December 1, 1995 is provided with the commercial rights and restrictions described elsewhere herein. All SOFTWARE and/or FIRMWARE provided to the U.S. Government pursuant to solicitations issued prior to December 1, 1995 is provided with RESTRICTED RIGHTS as provided for in FAR, 48 CFR 52.227-14 (JUNE 1987) or DFAR, 48 CFR 252.227-7013 (OCT 1988), as applicable.
7. **EXPORT RESTRICTIONS.** You agree that you will not export or re-export the SOFTWARE and/or FIRMWARE, any part thereof, or any process or service that is the direct product of the SOFTWARE and/or FIRMWARE (the foregoing collectively referred to as the “RESTRICTED COMPONENTS”), to any country, person or entity subject to U.S. export restrictions. You specifically agree not to export or re-export any of the RESTRICTED COMPONENTS (i) to any country to which the U.S. has embargoed or restricted the export of goods or services, which currently include, but are not necessarily limited to Cuba, Iran, Iraq, Libya, North Korea, Sudan and Syria, or to any national of any such country, wherever located, who intends to transmit or transport the RESTRICTED COMPONENTS back to such country; (ii) to any person or entity who you know or have reason to know will utilize the RESTRICTED COMPONENTS in the design,



development or production of nuclear, chemical or biological weapons; or (iii) to any person or entity who has been prohibited from participating in U.S. export transactions by any federal agency of the U.S. government. You warrant and represent that neither the U.S. Commerce Department, Bureau of Export Administration nor any other U.S. federal agency has suspended, revoked or denied your export privileges.

8. **DISCLAIMER OF WARRANTIES.** ZEBRA AND ITS SUPPLIERS PROVIDE THE SOFTWARE AND/OR FIRMWARE “AS IS” AND WITH ALL FAULTS, AND HEREBY DISCLAIM ALL OTHER WARRANTIES AND CONDITIONS, EITHER EXPRESS, IMPLIED OR STATUTORY, INCLUDING BUT NOT LIMITED TO ANY (IF ANY) IMPLIED WARRANTIES OR CONDITIONS OF MERCHANTABILITY, OF FITNESS FOR A PARTICULAR PURPOSE, OF LACK OF VIRUSES, AND OF LACK OF NEGLIGENCE OR LACK OF WORKMANLIKE EFFORT. ALSO, THERE IS NO WARRANTY OR CONDITION OF TITLE, OF QUIET ENJOYMENT, OR OF NONINFRINGEMENT. THE ENTIRE RISK ARISING OUT OF THE USE OR PERFORMANCE OF THE SOFTWARE AND FIRMWARE IS WITH YOU. ZEBRA DOES NOT WARRANT THAT THE OPERATION OF THE SOFTWARE OR FIRMWARE WILL BE UNINTERRUPTED OR ERROR FREE.
9. **EXCLUSION OF ALL DAMAGES.** TO THE MAXIMUM EXTENT PERMITTED BY APPLICABLE LAW, IN NO EVENT SHALL ZEBRA OR ITS SUPPLIERS BE LIABLE FOR ANY CONSEQUENTIAL, INCIDENTAL, DIRECT, INDIRECT, SPECIAL, PUNITIVE, OR OTHER DAMAGES WHATSOEVER (INCLUDING, WITHOUT LIMITATION, DAMAGES FOR ANY INJURY TO PERSON OR PROPERTY, DAMAGES FOR LOSS OF PROFITS, BUSINESS INTERRUPTION, LOSS OF BUSINESS INFORMATION, FOR LOSS OF PRIVACY FOR FAILURE TO MEET ANY DUTY INCLUDING OF GOOD FAITH OR OF REASONABLE CARE, FOR NEGLIGENCE, AND FOR ANY PECUNIARY OR OTHER LOSS WHATSOEVER) ARISING OUT OF OR IN ANY WAY RELATED TO THE USE OF OR INABILITY TO USE THE SOFTWARE OR FIRMWARE, WHETHER BASED ON CONTRACT, TORT, NEGLIGENCE, STRICT LIABILITY OR OTHERWISE, EVEN IF ZEBRA OR ANY SUPPLIER HAS BEEN ADVISED OF THE POSSIBILITY OF SUCH DAMAGES. THIS



EXCLUSION OF DAMAGES SHALL BE EFFECTIVE EVEN IF ANY REMEDY FAILS OF ITS ESSENTIAL PURPOSE.

10. LIMITATIONS AND RELEASE OF LIABILITY.

- To the extent that the SOFTWARE and/or FIRMWARE covered by this PSFLA includes emulation libraries, emulation libraries are offered “as is.” ZEBRA does not provide any warranty associated with the emulation libraries.
- The emulation library does not work 100% correctly or cover 100% of the functionality of the printer language being emulated. Modifications may be required for each target application. If such modification is necessary, prior to making any such modification, you are required to contact ZEBRA to obtain express written consent to make such modification.
- If the emulation library is sold separately by an authorized party other than ZEBRA (“RESELLER”—A party other than ZEBRA which is authorized by ZEBRA to distribute the SOFTWARE and/or FIRMWARE with its application so long as the SOFTWARE and/or FIRMWARE is used with a ZEBRA printer) or is sold bundled with a printer to an end-user by a RESELLER, and if claims are made by the RESELLER that the emulation library performs as a 100% emulation solution, ZEBRA is not responsible if the emulation library does not work as advertised by the RESELLER. Furthermore, ZEBRA is not liable for any damages directly or indirectly relating to such emulation library which is sold separately by the RESELLER or which is sold bundled with a printer to an end-user by the RESELLER.
- The SOFTWARE and FIRMWARE was provided to you at no additional charge and ZEBRA has included in this PSFLA terms that disclaim all warranties and liability for the SOFTWARE and FIRMWARE. To the full extent allowed by law, YOU HEREBY RELEASE ZEBRA AND ITS SUPPLIERS FROM ANY AND ALL LIABILITY ARISING FROM OR RELATED TO ALL CLAIMS CONCERNING THE SOFTWARE AND/OR FIRMWARE OR ITS USE. If you do not wish to accept the SOFTWARE OR FIRMWARE under the terms of this PSFLA, do not use the PRINTER enclosed with or otherwise associated with this PSFLA.

11. GOVERNING LAW. If you acquired the SOFTWARE and/or FIRMWARE in the United States of America, the laws of the State of Illinois, U.S.A. will apply to this contract. If you acquired this SOFTWARE and/or FIRMWARE outside of the United States of America, then local law may apply. If any provision of this PSFLA is held invalid, the remainder of this PSFLA shall continue in full force and effect.

12. QUESTIONS. Should you have any questions, or if you desire to contact ZEBRA for any reason, please contact the ZEBRA subsidiary serving your country, or write:

Zebra Technologies
333 Corporate Woods Parkway
Vernon Hills, IL 60061



Warranty Information

Effective December 30, 2002

All new Zebra products are warranted by the manufacturer to be free from defect in material and workmanship.

Printers and Related Hardware Products

Proof of purchase or shipment date is required to validate the warranty period. The warranty becomes void if the equipment is modified, improperly installed or used, damaged by accident or neglect, or if any parts are improperly installed or replaced by the user.

Note • Products returned must be packaged in the original or comparable packing and shipping container. In the event equipment is not so packaged, or if shipping damage is evident, it will not be accepted for service under warranty. Surface transportation charges for return to customers in the continental United States is paid by Zebra. Otherwise, Zebra pays CPT (carriage paid to) nearest airport; customer pays customs, duties, taxes, and freight from airport to destination. If Zebra determines that the product returned for warranty service or replacement is not defective as herein defined, the customer will pay all handling and transportation costs.

Printers

All printers (excluding printheads) are warranted against defect in material or workmanship for twelve (12) months from the purchase date.

Printheads

Since printhead wear is part of normal operation, the original printhead is covered by a limited warranty as indicated below. Warranty period begins on purchase date

Printhead	Warranty Period
Bar code label and receipt printer printheads	6 months
Plastic card printer printheads	12 months

To qualify for this warranty, the printhead must be returned to the factory or to an authorized service center. Customers are not required to purchase Genuine Zebra Supplies (media and/or ribbons) for warranty qualification. However, if it is determined that the use of inappropriate or inferior supplies has caused any defect in the printhead for which a warranty claim



is made, the user is responsible for Zebra's labor and material charges required to repair the defect. The warranty becomes void if the printhead is physically worn or damaged; also if it is determined that failure to follow the preventive maintenance schedule listed in the Users Guide has caused defect in the thermal printhead for which a warranty claim is made.

Related Hardware Items

Products are warranted to be free of defects in material and workmanship from the date of purchase according to this chart:

Product	Warranty Period
Accessories	1 month
Batteries	3 months
Cables	1 month
Chargers/Power Supplies	1 year
Hardware Keys	1 year
Keyboard Display Units	6 months
Parts	3 months
Pocket Eye®	1 year
Software	1 month
ZebraNet® PrintServers	3 years

Defective product must be returned to Zebra for evaluation. In the event of notification of defect within the warranty period, Zebra will replace the defective item provided there had not been damage resulting from user abuse, modification, improper installation or use, or damage in shipping or by accident or neglect.



Supplies Products

Supplies are warranted to be free from defect in material and workmanship for a period of six (6) months for media and twelve (12) months for ribbon from the date of shipment by Zebra. This is provided the user has complied with storage guidelines, handling, and usage of the supplies in Zebra printers.

Zebra's sole obligation under these warranties is to furnish parts and labor for the repair or possible replacement of products found to be defective in material or workmanship during the warranty period. Zebra may in its discretion issue a credit for any such defective products in such amount as it deems reasonable.

Repair Services

Zebra repairs are warranted against defects in material and workmanship for 90 days from the date of repair by Zebra. This excludes printheads, which are warranted separately. This warranty does not cover normal wear and tear. This warranty becomes void if the item is modified, improperly installed or used, or damaged by accident, neglect, or abuse.

Warranty Exclusions & Conditions Statement

The warranties given above are the only warranties given to you. No other warranties, express or implied, are given. Zebra does not make any *implied warranty of merchantability or fitness for a particular purpose* in connection with its sale of products or services. While Zebra's desire is to be responsive to your specific needs and questions, Zebra does not assume responsibility for any specific application to which any Products are applied, including, but not limited to, compatibility with other equipment. All statements, technical information, or recommendations relating to Zebra Products are based on tests believed to be reliable, but do not constitute a guaranty or warranty.

Zebra's maximum liability for warranty claims is limited to the invoice price of the Product claimed defective. Zebra does not assume responsibility for delays in replacement or repair of products. Zebra shall not under any circumstances whatsoever be liable to you or any other party for loss or profits, lost data, diminution of goodwill, or any other special or consequential damages whatsoever with respect to any warranty claim made by you. Specifically for software, Zebra is not liable for any incidental or consequential damages caused by abuse or misapplication of the software or by its use in violation of the U.S. copyright law or international treaty. No salesperson, representative, or agent of Zebra is authorized to make any guaranty, warranty, or representation that contradicts the foregoing. Any waiver, alteration, addition, or modification to the foregoing warranties must be in writing and signed by an executive officer of Zebra to be valid.



Zebra Technologies

333 Corporate Woods Parkway
Vernon Hills, IL 60061-3109 U.S.A.
Phone +1 847.634.6700 or +1 800.423.0442
Fax + 1 847.913.8766
www.zebra.com



Zebra Technologies

333 Corporate Woods Parkway
Vernon Hills, Illinois 60061.3109 U.S.A.
Telephone +1 847.634.6700
Facsimile +1 847.913.8766

Zebra Technologies Europe Limited

Zebra House
The Valley Centre, Gordon Road
High Wycombe
Buckinghamshire HP13 6EQ, UK
Telephone +44 (0)1494 472872
Facsimile +44 (0)1494 450103