



# PlasmaView™

VP-6000 VHD

HIGH DEFINITION PLASMA DISPLAY PANEL  
and CONTROLLER



---

# THREE YEAR LIMITED WARRANTY

## For Plasma Displays

Congratulations on your purchase of a Vidikron video product and welcome to the Vidikron family! With proper installation, setup and care, you should enjoy many years of unparalleled video performance.

This is a LIMITED WARRANTY as defined in the Magnuson-Moss Warranty Act. Please read it carefully and retain it with your other important documents.

### **WHAT IS COVERED UNDER THE TERMS OF THIS LIMITED WARRANTY:**

**SERVICE LABOR:** Vidikron will pay for service labor by a Vidikron Authorized Service Center when needed as a result of a manufacturing defect for a period of three (3) years from the effective date of delivery to the end user (excluding the plasma glass panel).

**PARTS** (not including plasma glass panel): Vidikron will provide new or rebuilt replacement parts for the parts that fail due to defects in materials or workmanship for a period of three (3) years from the effective date of delivery to the end user. Such replacement parts are then subsequently warranted for the remaining portion (if any) of the original warranty period.

**PLASMA GLASS PANEL:** Vidikron will pay for service labor by a Vidikron Authorized Service Center when needed as a result of a manufacturing defect for a period of one (1) year from the effective date of delivery to the end user. In addition, Vidikron will provide new or rebuilt replacement parts for the parts that fail due to defects in materials or workmanship for a period of one (1) year from the effective date of delivery to the end user. Such replacement parts are then subsequently warranted for the remaining portion (if any) of the original warranty period.

### **WHAT IS NOT COVERED UNDER THE TERMS OF THIS LIMITED WARRANTY:**

Image burn-in on plasma display panels is specifically excluded from coverage under this Limited Warranty. Image burn-in is the result of misuse of the product and therefore cannot be repaired under the terms of this Limited Warranty.

Normal viewing material such as television/satellite broadcasts, videotape or DVDs (not put into pause for extended periods of time) will not cause damage to your display under normal conditions. Many DVD players are also equipped with screen savers for this reason.

**TO AVOID IMAGE RETENTION (Burn-in):** Please ensure that still images are left on your plasma display panel for no more than a few minutes. Also ensure that images displayed in the 4:3 aspect ratio mode (black or gray stripes, but no picture information is present on the left and right edges of the screen) are used as infrequently as possible. This will prevent permanent image burns on your plasma display panel, which can be seen permanently under certain conditions once burn-in has occurred.

The types of images to avoid include video games, still images and computer screens with stationary tool bars and icons. (This is why computers are equipped with screen savers – to prevent still images from burning into the monitor's phosphors after being displayed continuously for an extended period of time).

This Limited Warranty only covers failure due to defects in materials and workmanship that occur during normal use and does not cover normal maintenance. This Limited Warranty does not cover cabinets or any appearance items; failure resulting from accident, misuse, abuse, neglect, mishandling, misapplication, faulty or improper installation or setup adjustments; improper maintenance, alteration, improper use of any input signal; damage due to lightning or power line surges, spikes and brownouts; damage that occurs during shipping or transit; or damage that is attributed to acts of God. In the case of remote control units, damage resulting from leaking, old, damaged or improper batteries is also excluded from coverage under this Limited Warranty.

---

CAUTION: THIS LIMITED WARRANTY ONLY COVERS VIDIKRON PRODUCTS PURCHASED FROM VIDIKRON AUTHORIZED DEALERS. ALL OTHER PRODUCTS ARE SPECIFICALLY EXCLUDED FROM COVERAGE UNDER THIS WARRANTY. MOREOVER, DAMAGE RESULTING DIRECTLY OR INDIRECTLY FROM IMPROPER INSTALLATION OR SETUP IS SPECIFICALLY EXCLUDED FROM COVERAGE UNDER THIS LIMITED WARRANTY. IT IS IMPERATIVE THAT INSTALLATION AND SETUP WORK BE PERFORMED ONLY BY AN AUTHORIZED VIDIKRON DEALER TO PROTECT YOUR RIGHTS UNDER THIS WARRANTY. THIS WILL ALSO ENSURE THAT YOU ENJOY THE FINE PERFORMANCE OF WHICH YOUR VIDIKRON PRODUCT IS CAPABLE WHEN INSTALLED AND CALIBRATED BY VIDIKRON AUTHORIZED PERSONNEL.

#### **RIGHTS, LIMITS AND EXCLUSIONS:**

Vidikron limits its obligations under any implied warranties under state laws to a period not to exceed the warranty period. There are no express warranties. Vidikron also excludes any obligation on its part for incidental or consequential damages related to the failure of this product to function properly. Some states do not allow limitations on how long an implied warranty lasts, and some states do not allow the exclusion or limitation of incidental or consequential damages. So the above limitations or exclusions may not apply to you. This warranty gives you specific legal rights, and you may also have other rights that vary from state to state.

#### **EFFECTIVE WARRANTY DATE:**

This warranty begins on the effective date of delivery to the end user. For your convenience, keep the original bill of sale as evidence of the purchase date.

#### **IMPORTANT -- WARRANTY REGISTRATION:**

Please fill out and mail your warranty registration card. It is imperative that Vidikron knows how to reach you promptly if we should discover a safety problem or product update for which you must be notified.

#### **CONTACT A VIDIKRON AUTHORIZED SERVICE CENTER TO OBTAIN SERVICE:**

Repairs made under the terms of this Limited Warranty covering your Vidikron video product will be performed at the location of the product, during usual working hours, providing location of product is within normal operating distance from a Vidikron Authorized Service Center. In some instances it may be necessary for the product to be returned to the Vidikron factory for repairs. If, solely in Vidikron's judgment, location of product to be repaired is beyond normal operating distance of the closest Vidikron Authorized Service Center, or the repair requires the unit be returned to the Vidikron factory, it is the owner's responsibility to arrange for shipment of the product for repair. These arrangements must be made through the selling Vidikron Dealer. If this is not possible, contact Vidikron directly for a Return Authorization number and shipping instructions. Vidikron will return product transportation prepaid in the United States, unless no product defect is discovered. In that instance, shipping costs will be the responsibility of the owner.

#### **COPYRIGHT AND TRADEMARKS:**

© Copyright 2006 Vidikron, a Runco International Company. This document contains proprietary information protected by copyright, trademark and other intellectual property laws. All rights are reserved. No part of this manual may be reproduced by any mechanical, electronic or other means, in any form, without prior written permission of the manufacturer.

Vidikron, Vision, DVSI, Imagix, CineWide, AutoScope, V<sup>2</sup> Aperture Control, CSMS and IntelliWide are trademarks of Runco, LLC. All other trademarks and registered trademarks used in this document are the property of their respective owners.

Vidikron products are manufactured under one or more of the following patents: US. Patent 6755540 and Other Patents Pending.

---

**ADDITIONAL INFORMATION:**

To locate the name and address of the nearest Vidikron Authorized Service Center, or for additional information about this Limited Warranty, please call or write:

**VIDIKRON**  
**Attn: Customer Service Department**  
**2900 Faber Street**  
**Union City, CA 94587**  
**Ph: (510) 324-5900**  
**Fax: (510) 324-5905**  
**Toll Free: (888) 4VIDIKRON**

---

**VIDIKRON PRODUCT INFORMATION**  
**RETAIN THIS INFORMATION FOR YOUR RECORDS**

---

Model Purchased

---

Date

---

Serial Number

---

Vidikron Authorized Dealer Name

---

Address

---

City

---

State/Province

---

Postal Code

---

Phone

---

Fax

# Safety Precautions

Thank you for your purchase of this quality Vidikron video projector! It has been designed to provide you with the quality of video that is expected in a home theater. For the best performance, please read this manual carefully as it is your guide through the menus and operation.

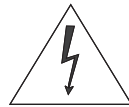
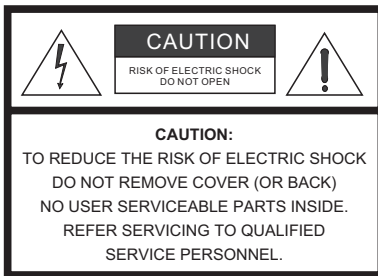

## WARNING

This symbol is intended to alert the user to the presence of uninsulated "dangerous voltage" within the product's enclosure that may be of sufficient magnitude to constitute a risk of electric shock.



This symbol is intended to alert the user to the presence of important operating and maintenance (servicing) instructions in the literature accompanying the appliance.

This equipment has been tested and found to comply with the limits for a Class B digital device, pursuant to Part 15 of the FCC Rules. These limits are designed to provide reasonable protection against harmful interference in a residential installation.

1. Read these instructions.
2. Keep these instructions.
3. Heed all warnings.
4. Do not use this equipment near water, outdoors or otherwise exposed to the elements.
5. Clean only with a dry cloth.
6. Do not block any ventilation openings.
7. Do not install near any heat sources such as radiators, heat registers, stoves, or other apparatus (including amplifiers) that produce heat.
8. Do not defeat the safety feature of the polarized or grounding type plug. A polarized type plug has two blades with one wider than the other. A grounding type plug has two blades and a third grounding prong. The third prong is provided for your safety. If the provided plug does not fit into your outlet, consult an electrician for the replacement of the obsolete outlet.
9. The 12V trigger only outputs DC 12V signal for triggering. Do not connect to any other power input or output. This could cause damage to this unit.
10. Only use accessories specified by Vidikron.
11. Keep the packing material in case the equipment should ever need to be shipped.
12. Unplug this projector during lightning storms or when it will not be used for an extended period of time.
13. The lamp becomes extremely hot during operation. Allow the projector to cool down for approximately 45 minutes prior to removing the lamp assembly for replacement. Do not operate lamps beyond the rated lamp life. Excessive operation of lamps beyond rated life could cause them to explode in rare occasions.
14. Refer all servicing to qualified service personnel. Servicing is required when the projector has been damaged in any way, objects have fallen or spilled into the projector, the projector has been exposed to rain or moisture, does not operate normally, or has been dropped.

# Table of Contents

<b>TWO YEAR LIMITED WARRANTY .....</b>	<b>iii</b>
<b>Safety Precautions .....</b>	<b>vi</b>
<b>1. Introduction .....</b>	<b>1</b>
About This Manual .....	1
Target Audience.....	1
If You Have Comments About This Manual.....	1
Textual and Graphic Conventions .....	1
Using This Manual .....	2
Description, Features and Benefits .....	3
Key Features and Benefits.....	3
Parts List .....	4
<b>2. Controls and Functions .....</b>	<b>5</b>
PlasmaView VHD at a Glance .....	5
Controls and Indicators .....	5
Connectors .....	6
VHD Controller Front Panel .....	8
VHD Controller Rear Panel .....	9
Outputs.....	9
Inputs .....	9
VHD Controller Remote Control .....	11
<b>3. Installation .....</b>	<b>15</b>
Remote Control .....	15
Notes on Batteries .....	15
Notes on Remote Control Operation.....	15
Quick Setup .....	17
Installation Considerations .....	18
High-Altitude Operation .....	18
Mounting the PlasmaView VHD on a Wall or Table Stand.....	18
Ambient Light .....	19
Ventilation.....	19
Other Considerations .....	20
Connections to the PlasmaView VHD and VHD Controller .....	21
Connecting the PlasmaView VHD to the VHD Controller .....	21
Connecting Source Components to the VHD Controller .....	23

---

RS-232 Controller Connection .....	27
Connecting 12-Volt Trigger Outputs to External Equipment.....	27
Connecting an External IR Receiver to the VHD Controller .....	28
Cable Management.....	28
<b>4. Operation .....</b>	<b>29</b>
Turning on the Power .....	29
Selecting the Input Source .....	30
Setting the Computer Display Properties .....	30
Using the On-Screen Menus .....	32
Main Menu .....	34
Input Source .....	34
Aspect Ratio .....	34
Picture .....	36
Input Position.....	39
ISF Presets.....	40
Information .....	40
Calibration.....	41
Service.....	43
<b>5. Maintenance and Troubleshooting .....</b>	<b>47</b>
Cleaning .....	47
Cleaning the Display Panel Body and Remote Control.....	47
Cleaning the Screen.....	47
Cleaning the Vents .....	47
Troubleshooting Tips .....	48
<b>6. Serial Communications .....</b>	<b>51</b>
RS-232 Connection and Port Configuration .....	51
Serial Command Syntax .....	51
<b>7. Specifications .....</b>	<b>57</b>
PlasmaView VHD Specifications .....	57
VHD Controller Specifications .....	58
PlasmaView VHD Dimensions .....	59
Computer/Video Signal Compatibility .....	60
<b>APPENDIX A. PlasmaView VHD Service Remote Control .....</b>	<b>A-1</b>
Overview .....	A-1
Service/Setup Menu .....	A-3
Video NR (Noise Reduction) .....	A-3
MPEG Filter.....	A-4



## List of Figures

2-1. PlasmaView VHD Front-Panel Controls and Indicators . . . . .	5
2-2. PlasmaView VHD Rear Panel . . . . .	6
2-3. VHD Controller Front Panel . . . . .	8
2-4. VHD Controller Rear Panel . . . . .	9
2-5. VHD Controller Remote Control . . . . .	11
3-1. Available Range of the Remote Control . . . . .	15
3-2. Ventilation Requirements for Enclosure Mounting . . . . .	19
3-3. Connecting the PlasmaView VHD to the VHD Controller. . . . .	21
3-4. RS-232 Connection from the VHD Controller to the PlasmaView VHD . . . . .	22
3-5. DVI Source Connections . . . . .	23
3-6. Digital (DTV) RGB Connections . . . . .	24
3-7. Analog RGB Connections. . . . .	25
3-8. Composite, S-Video and Component Video Connections. . . . .	26
3-9. RS-232 Control System Connection. . . . .	27
3-10. Connecting 12-Volt Trigger Outputs . . . . .	27
3-11. External IR Receiver Connection. . . . .	28
3-12. Installing the Cable Ties. . . . .	28
4-1. VHD Controller OSD Menu Structure for PlasmaView VHD. . . . .	33
4-2. Typical PLUGE Pattern for Adjusting Brightness . . . . .	36
4-3. Typical Gray Bar Pattern for Adjusting Contrast . . . . .	37
4-4. Typical Color Bar Pattern for Adjusting Color Saturation and Tint . . . . .	38
4-5. Typical Test Pattern for Adjusting Sharpness. . . . .	39
7-1. PlasmaView VHD Dimensions (with Optional Table Stand) . . . . .	59
A-1. PlasmaView VHD Service Remote Control . . . . .	A-1
A-2. PlasmaView VHD Setup Menu. . . . .	A-3

**Notes:**

# Introduction

This Owner's Manual describes how to install, set up and operate the Vidikron PlasmaView VP-6000 VHD High-Definition Plasma Display. Throughout this manual, the Vidikron PlasmaView VP-6000 VHD High-Definition Plasma Display is referred to simply as the "PlasmaView VHD."

Vidikron has prepared this manual to help home theater installers and end users get the most out of the PlasmaView VHD.

Vidikron has made every effort to ensure that this manual is accurate as of the date it was printed. However, because of ongoing product improvements and customer feedback, it may require updating from time to time. You can always find the latest version of this and other Vidikron product manuals on-line, at [www.Vidikron.com](http://www.Vidikron.com).

Vidikron welcomes your comments about this manual. Send them to [info@Vidikron.com](mailto:info@Vidikron.com).

**Text Conventions:** The following conventions are used in this manual, in order to clarify the information and instructions provided:

- Remote control button identifiers are set in upper-case bold type; for example, "Press **EXIT** to return to the previous menu."
- Computer input (commands you type) and output (responses that appear on-screen) is shown in monospace (fixed-width) type; for example: "To change the aspect ratio to Anamorphic, type ANAMORPHIC <Enter>."
- All keys with functional names are initial-capped, set in bold type and enclosed in angle brackets. These keys are the following: <Enter>, <Spacebar>, <Control>, <Esc> and <Tab>.
- <Enter> indicates that you may press either the RETURN or ENTER key on your computer keyboard if it has both keys.

In addition to these conventions, underlining, boldface and/or italics are occasionally used to highlight important information, as in this example:



*A carriage return **must** be used after each command or string.*

## 1.1 About This Manual

### ◀ Target Audience

### ◀ If You Have Comments About This Manual...

### ◀ Textual and Graphic Conventions

**Graphic Conventions:** These symbols appear in numerous places throughout the manual, to emphasize points that you must keep in mind to avoid problems with your equipment or injury:



**Tip**

*TIPS highlight time-saving short cuts and helpful guidelines for using certain features.*



**Note**

*NOTES emphasize text with unusual importance or special significance. They also provide supplemental information.*



**Caution**

*CAUTIONS alert users that a given action or omitted action can degrade performance or cause a malfunction.*



**WARNING**

*WARNINGS appear when a given action or omitted action can result in damage to the equipment, or possible non-fatal injury to the user.*



**DANGER!**

*DANGER appears when a given action can cause severe injury or death.*

## 1.2 Using This Manual

Use the following table to locate the specific information you need in this manual.

<b>If you need...</b>	<b>... Turn to page:</b>
Information about obtaining service	iv
General information about the PlasmaView VP-6000 VHD High-Definition Plasma Display	3
Installation instructions	15
First-time configuration instructions	29
Advanced configuration instructions	41
Troubleshooting tips	48
Specifications for the PlasmaView VP-6000 VHD High-Definition Plasma Display	60

The PlasmaView VHD flat-panel plasma monitor brings outstanding picture quality to its size category with true, high-definition native resolution of 1365 x 768 for no-compromise viewing of any video source.

The PlasmaView VHD is supplied with Vidikron's next-generation VHD Controller, featuring advanced Imagix™ processing. This controller produces stunning video imagery, elevating even standard NTSC material to near high-definition levels. The VHD Controller provides for a pure digital signal path from input to output, making this system ready for Vidikron's exclusive LiveLink™ DVI cable solution to preserve HD signal quality over long runs.

Multiple aspect ratio control includes Vidikron's IntelliWide™ mode for viewing 4:3 material in widescreen with no loss of picture quality.

The PlasmaView VHD's black level performance and shadow detail capability have been enhanced with Active Gray Scale Rendering to provide smoother transitions from dark to light, resulting in richly detailed textures even in shadowy scenes.

The PlasmaView VHD is easily integrated into custom installation systems. Both RS-232C and IR control interfaces are incorporated for simple automation. Its profile is less than 5-1/2 inches thin for wall-mounting simplicity.

The PlasmaView VHD offers these key features and benefits:

- 16:9 Native Resolution: 1365 x 768
- Multiple Aspect Ratios with IntelliWide™ Mode
- 160 degree horizontal/vertical viewing angle
- Accepts all DTV formats (via outboard decoder), including 1080i, 720p and 480p
- Less than 5-1/2 inches deep
- Two DVI Inputs (on VHD Controller) with High-bandwidth Digital Content Protection (HDCP)
- Exceptional detail and artifact-free video enhancement
- Imagix™ video processing with 3:2 film detection circuitry

---

### 1.3 Description, Features and Benefits

#### ◀ **Key Features and Benefits**

**Parts List** ➤ Your PlasmaView VHD is shipped with the following items. If any items are missing or damaged, please contact your Vidikron dealer or Vidikron Customer Service at (888) 4VIDIKRON.

- PlasmaView VP-6000 VHD High-Definition Plasma Display
- AC Power Cords (2)
- Remote Control Unit and two (2), AAA-size batteries
- Service Remote Control Unit and two (2), AA-size batteries
- RJ-11 Telephone Cable, 50 feet (15.24 meters)
- Serial Port Adapter, RJ-11 Female to DB-9 Female
- Rack-mount hardware for the VHD Controller
- Cleaning Cloth
- Cable Ties (2)
- Warranty information and registration card
- Vidikron PlasmaView VP-6000 VHD Owner's Operating Manual (this document)

**Optional Accessories:**

- Wall Mount Kit
- Table Stand
- LiveLink™ DVI Cabling System

# Controls and Functions

## 2.1 PlasmaView VHD at a Glance

◀ *Controls and Indicators*

Figure 2-1 shows the PlasmaView VHD front-panel controls and indicators.

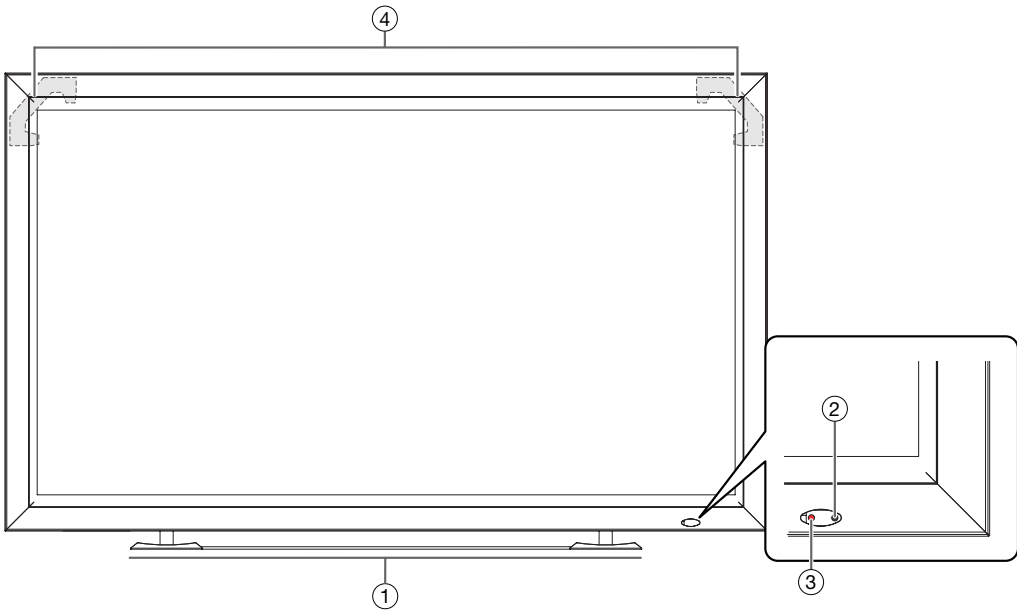

**Figure 2-1. PlasmaView VHD Front-Panel Controls and Indicators**

1. **DISPLAY STAND**  
Optional accessory for tabletop installations.
2. **REMOTE CONTROL SENSOR**  
Receives the signals from the remote control.
3. **STANDBY/ON INDICATOR**
  - Lights green to indicate normal operation;
  - Lights red to indicate that the PlasmaView VHD is in standby mode;
  - Flashes green or red (twice per second) to indicate an error condition.
4. **HANDLES (at the rear of the panel)**  
ALWAYS use the handles when carrying the unit.

**Connectors** ➤ Figure 2-2 shows the rear-panel connector and power switch locations on the PlasmaView VHD.

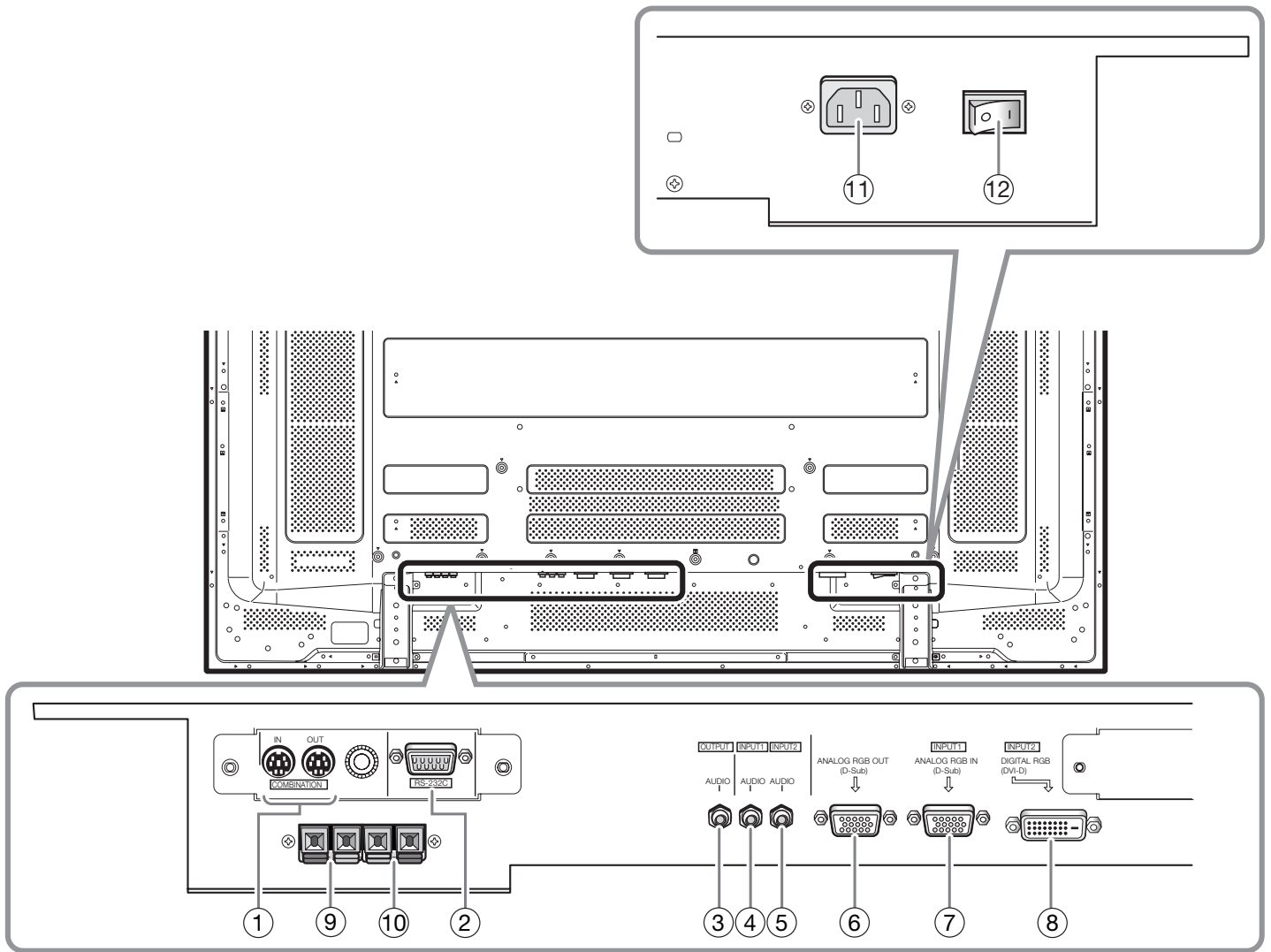

**Figure 2-2. PlasmaView VHD Rear Panel**



1. **COMBINATION IN/OUT**  
Not used.
2. **RS-232C (9-pin, male D-Sub)**  
Connect the RS-232 OUT port on the VHD Controller to this input.
3. **AUDIO (OUTPUT) (3.5-mm stereo mini jack)**  
Not used with this model.
4. **AUDIO (INPUT 1) (3.5-mm stereo mini jack)**  
Not used with this model. Connect the audio outputs from your sources to an external audio receiver.
5. **AUDIO (INPUT 2) (3.5-mm stereo mini jack)**  
Not used with this model. Connect the audio outputs from your sources to an external audio receiver.
6. **ANALOG RGB OUT (INPUT 1) (15-pin D-Sub)**  
If desired, connect this output to the RGB input of a second display device.

**Note**

*This output is not active when the PlasmaView VHD is off or in standby mode.*

7. **ANALOG RGB IN (INPUT 1) (15-pin D-Sub)**  
Connect the RGBHV (5xBNC) output from the VHD Controller here.
8. **DIGITAL RGB (INPUT 2) (DVI-D)**  
HDCP-compliant digital video input. **Connect the DVI output from the VHD Controller to this input.**
9. **EXTERNAL SPEAKER OUTPUT (RIGHT)**  
Not used. Connect speakers to an external audio amplifier/receiver.
10. **EXTERNAL SPEAKER OUTPUT (LEFT)**  
Not used. Connect speakers to an external audio amplifier/receiver.
11. **POWER INPUT (100 to 240 VAC)**  
Connect the PlasmaView VHD to power here, using the included power cord.
12. **MAIN POWER SWITCH**  
Connects or disconnects the PlasmaView VHD from the AC power source.

## 2.2 VHD Controller Front Panel

Figure 2-3 shows the controls and indicators on the VHD Controller front panel; the paragraphs that follow describe them.

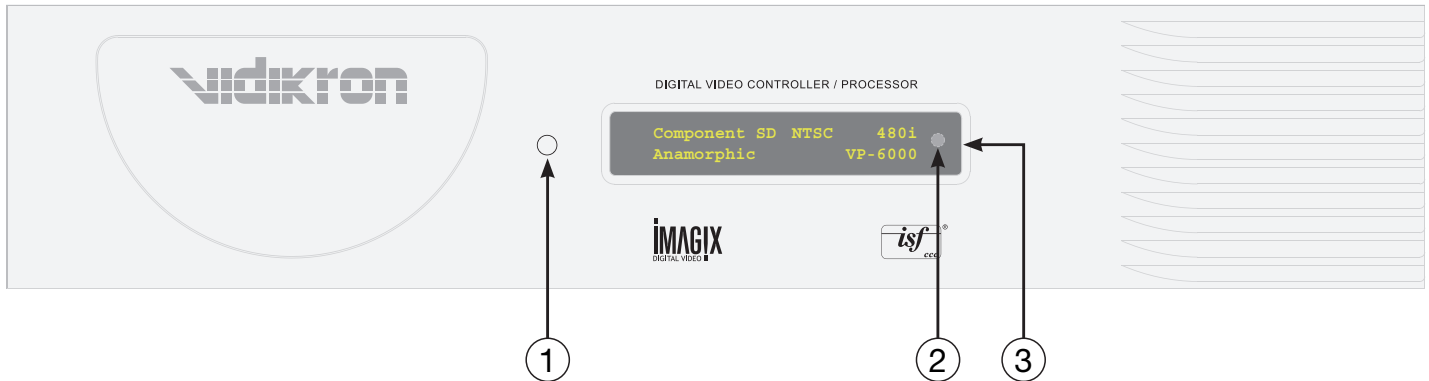

Figure 2-3. VHD Controller Front Panel

1. **POWER BUTTON**  
Press once to toggle from standby mode to on mode. Press it again to return to standby mode. For a discrete on or off command, you can use the direct access buttons on the remote control.
2. **IR SENSOR**  
Receives IR commands from the remote.
3. **VACUUM FLUORESCENT DISPLAY**  
Can be used instead of the On-Screen Display (OSD). Displays currently-selected menu or – if no menu is selected – the current source, signal format (NTSC or PAL), input resolution and aspect ratio.

Figure 2-4 shows the rear connector panel on the VHD Controller.

## 2.3 VHD Controller Rear Panel

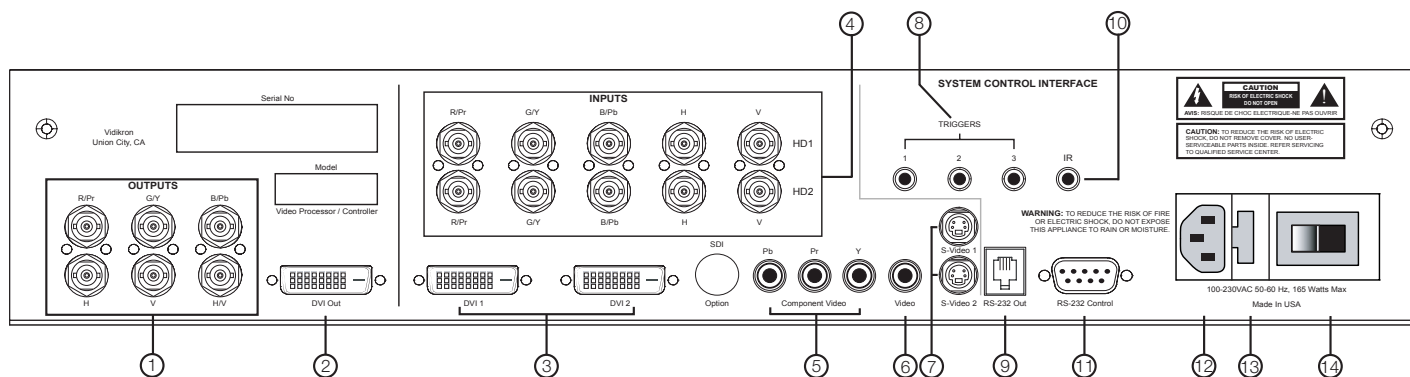

Figure 2-4. VHD Controller Rear Panel

### 1. ANALOG OUTPUTS (RGBHV)

Connect these to the **ANALOG RGB IN** input of the PlasmaView VHD, using a 5 x BNC-to-VGA breakout cable.

← **Outputs**

### 2. DVI OUT

Connect this to the **DIGITAL RGB (DVI-D)** input on the PlasmaView VHD.

### 3. DVI 1 / DVI 2 (Digital)

Two, HDCP-compliant digital video inputs for connecting a DVD player or HD tuner with a DVI or HDMI output.

← **Inputs**

### 4. HD1 / HD2 (5 x Analog BNCs)

Two inputs (five BNCs per input) for connecting either RGB or component high-definition television signals. The VHD Controller automatically detects the signal format: RGB(HV) or YPrPb, 480p, 720p, 480i, 576i or 1080i.

### 5. COMPONENT VIDEO (RCA connectors)

Standard Definition (480i/576i) Component (YPrPb) input. This is the input for component video from sources such as DVD players.



**Tip**

*For best results, do not run your DVD player in progressive mode.*

6. **COMPOSITE VIDEO INPUT**  
Standard composite video input for connecting a VCR, camcorder, laser disc player or other composite video source.
7. **S-VIDEO 1 / S-VIDEO 2**  
Two, standard S-Video inputs for connecting a DVD player, satellite receiver or Super VHS (S-VHS) VCR.
8. **12-VOLT (750 mA) TRIGGER OUTPUTS**  
Connection for up to three (3), 12-volt trigger-controlled devices.
9. **RS-232 OUTPUT (6-Wire, RJ-11 jack)**  
Connect this to the **RS-232C** input of the PlasmaView VHD, using the supplied serial port adapter and communication cable.
10. **IR**  
Wired input from an external remote control or infrared receiver. It is a 3.5-mm, mini phono jack, wired as follows:  
Ring = +5V  
Tip = IR Input  
Sleeve = Ground



**Note**

*When an external remote control or infrared receiver is connected to the wired IR input, the IR sensor on the front of the VHD Controller is disabled.*

11. **RS-232 CONTROL PORT**  
A female, 9-pin D-sub connector for interfacing with a PC or home theater automation/control system.
12. **POWER INPUT (100 to 240 VAC)**  
Connect the VHD Controller to power here.
13. **MAIN AC FUSE**  
This is the main AC input fuse (5mm x 20mm, 500 mA, 250V slow-blow).
14. **MAIN POWER SWITCH**  
Disconnects or applies power to the VHD Controller.

Figure 2-5 shows the VHD Controller remote control, and the paragraphs that follow describe its functionality.

## 2.4 VHD Controller Remote Control

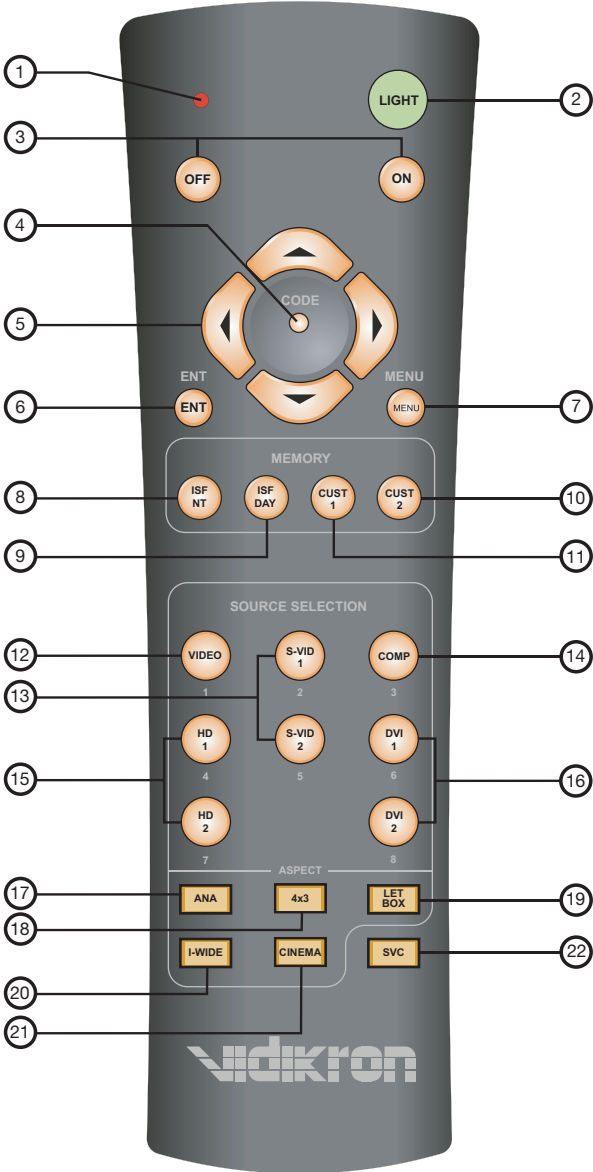

Figure 2-5. VHD Controller Remote Control

1. **IR OUTPUT INDICATOR**  
Lights when a button is pressed to indicate that an IR signal is being transmitted.
2. **LIGHT**  
Press to illuminate the buttons.
3. **ON / OFF**  
Press to turn the PlasmaView VHD on or off.
4. **CODE**  
For service use only.
5. **Cursor Keys (▲, ◀, ▼, ▶)**  
Use these buttons to select items or settings, adjust settings or switch display patterns.

When no menus are present on-screen, the **UP** and **DOWN** buttons toggle through the available aspect ratios, in this order:

**UP** Button = Anamorphic - Standard (4:3) - Letterbox - IntelliWide - Cinema

**DOWN** Button = Cinema - IntelliWide - Letterbox - Standard (4:3) - Anamorphic

Likewise, the **LEFT** and **RIGHT** buttons toggle through the different source inputs, in this order:

**LEFT** Button = HD2 Pass Thru - HD1 Pass Thru - DVI 2 - DVI 1 - HD/RGB2 - HD/RGB 1 - Component SD - S-Video 2 - S-Video 1 - Composite

**RIGHT** Button = Composite - S-Video 1 - S-Video 2 - Component SD - HD/RGB 1 - HD/RGB 2 - DVI 1 - DVI 2 - HD1 Pass Thru - HD2 Pass Thru

6. **ENT (Enter)**  
Press to select a highlighted menu item or confirm a changed setting.
7. **MENU**  
Press this button to access the OSD controls, or to exit the current menu and return to the previous one.

**Memory Preset Buttons:**

8. **ISF NT (Night)**  
Press to recall settings for the current input from the "ISF Night" memory preset.
9. **ISF DAY**  
Press to recall settings for the current input from the "ISF Day" memory preset.
10. **CUST 1**  
Press to recall settings for the current input from the "Custom 1" memory preset.
11. **CUST 2**  
Press to recall settings for the current input from the "Custom 2" memory preset.

---

**Input Selection Buttons:** Use these buttons to select an input source directly or to enter numeric characters, as follows.

12. **VIDEO (1)**  
Press to select Composite video input as the source.
13. **S-VID 1 (2)/ S-VID 2 (5) (S-Video)**  
Press to select an S-Video input.
14. **COMP (Component) (3)**  
Press to select Component SD (480i/576i) video input as the source.
15. **HD 1 (4) / HD 2 (7)**  
Press to select a HD (RGBHV or YPbPr component) input.
16. **DVI 1 (6) / DVI 2 (8)**  
Press to select a Digital Video input.

**Aspect Ratio Selection Buttons:** Use these buttons to select an aspect ratio directly or to enter numeric characters, as follows.

17. **ANA (16:9) (9)**  
For viewing 16:9 DVDs or HDTV programs in their native aspect ratio.
18. **4X3 (4:3) (0)**  
Scales the input signal to fit 4:3 display mode in the center of the screen.
19. **LETBOX (Letterbox)**  
For viewing LaserDisc movies or non-anamorphic DVDs on a 4:3 screen.
20. **I-WIDE (IntelliWide)**  
Enlarges a 4:3 image horizontally in a NON-linear fashion to fit 16:9 full screen display.
21. **CINEMA**  
For viewing 2.35:1 source material.
22. **SVC**  
Not used.

**Notes:**



# Installation

To install batteries in the remote control:

1. Press down the tab on the cover and pull the cover in the direction of the arrow.
2. Insert the included batteries. Ensure that the polarities correctly match the  $\oplus$  and  $\ominus$  markings inside the battery compartment.
3. Insert the lower tab of the cover into the opening, and press down the cover until it clicks in place.

- When installing batteries, make sure that the battery polarities are correct.
- Do not mix an old battery with a new one or different types of batteries.
- If you will not use the remote control for a long time, remove the batteries to avoid damage from battery leakage.

The remote control can be used to control the PlasmaView VHD within the ranges shown in Figure 3-1.

## 3.1 Remote Control

### ◀ Notes on Batteries

### ◀ Notes on Remote Control Operation



**Figure 3-1. Available Range of the Remote Control**

- Do not drop the remote control or expose it to moisture or high temperature.
- The remote control may malfunction under a fluorescent lamp. If that occurs, move the plasma display away from the fluorescent lamp.
- Make sure that there is nothing obstructing the infrared beam between the remote control and the IR receiver on the plasma display.



**Note**

*The signal from the remote control can be reflected by walls or other surfaces.*

- If the effective range of the remote control decreases, or it stops working, replace the batteries with new ones.
- Ambient conditions may possibly impede the operation of the remote control. If this happens, point the remote control at the plasma display and repeat the operation.

Table 3-1 gives a quick overview of the PlasmaView VHD installation process. The sections following this one provide detailed instructions.

## 3.2 Quick Setup



### Note

*Installation should be performed by a qualified custom video installation specialist.*

**Table 3-1. Installation Overview**

Step	Procedure	For Details, refer to page...
1	Mount the PlasmaView VHD on a wall or table stand	18
2	Connect the VHD Controller to the PlasmaView VHD	21
3	Connect signal sources to the VHD Controller	23
4	Connect external controller to VHD Controller RS-232 port (optional)	27
5	Apply power to the PlasmaView VHD	29
6	If using the PlasmaView VHD with a computer, adjust computer display properties	30
7	Display calibration: adjust the following <b>for each input</b> ; save settings when finished: <ul style="list-style-type: none"> <li>• Aspect ratio</li> <li>• Brightness</li> <li>• Contrast</li> <li>• Color level</li> <li>• Tint</li> <li>• Sharpness</li> </ul>	34 through 42

---

### 3.3 Installation Considerations

Proper installation of your PlasmaView VHD will ensure the highest possible picture quality. Whether you are installing the PlasmaView VHD temporarily or permanently, you should take the following into account to ensure that it performs optimally.

#### **High-Altitude Operation** ➤

Due to the design of all plasma glass panels made by every manufacturer, and the interaction between ambient air pressure and the plasma gases contained inside of the panel, reliable operation of your plasma display cannot be assured during operation at certain high-altitude locations.

Vidikron has found this plasma monitor to operate reliably at altitudes of up to 6000 MSL (mean sea level). At elevations higher than this, each panel may react differently, depending upon the altitude, air pressure, humidity and other meteorological factors.

For this reason, Vidikron makes no warranties or claims as to the reliable operation of the PlasmaView VHD at altitudes greater than 6000 feet above sea level. If you are planning to use this product at a location above 6000 feet, please contact Vidikron technical support for further information.

#### **Mounting the PlasmaView VHD on a Wall or Table Stand** ➤

To install the PlasmaView VHD, you will need either an optional table stand or wall-mounting kit. The PlasmaView VHD cannot be installed on its own.

If you do decide to wall-mount the PlasmaView VHD, ensure that the wall-mount bracket is installed according to the instructions included with it. The wall must be capable of supporting a redundant weight factor three (3) times the weight of the display, or be reinforced.

Vidikron recommends that this be done by a custom installation specialist.



#### **Note**

*Use only a Vidikron-approved wall-mount kit or table stand that is specifically designed for your display.*

You can attach your optional mounts or stand to the PlasmaView VHD in either of two ways:

- While it is upright.

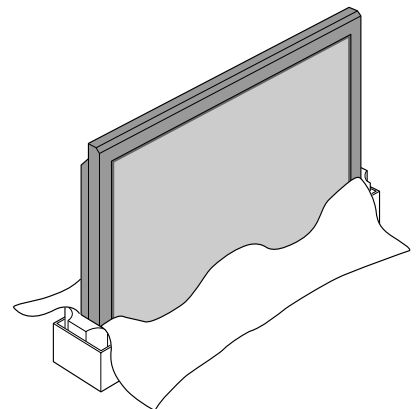

- As it lies flat with the screen face down. Place the protective sheet, which was wrapped around the plasma monitor when it was packaged, between the screen and your work surface to avoid scratching or otherwise damaging the screen surface.

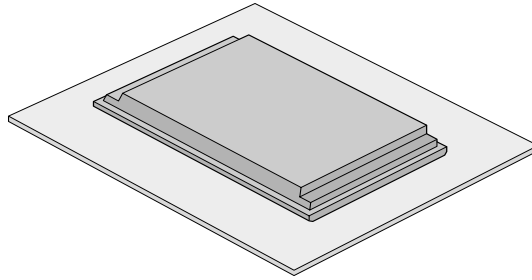

In general, minimize or eliminate light sources directed at the display. Contrast ratio in your images will be noticeably reduced if light directly strikes the display, such as when a shaft of light from a window or floodlight falls on the image. Images may then appear washed out and less vibrant.

◀ **Ambient Light**

If you are mounting the PlasmaView VHD in an enclosure, leave at least 2 inches (50 mm) of space on all sides between it and surrounding objects, as shown in Figure 3-2. This allows heat to disperse, maintaining the proper operating temperature.

◀ **Ventilation**

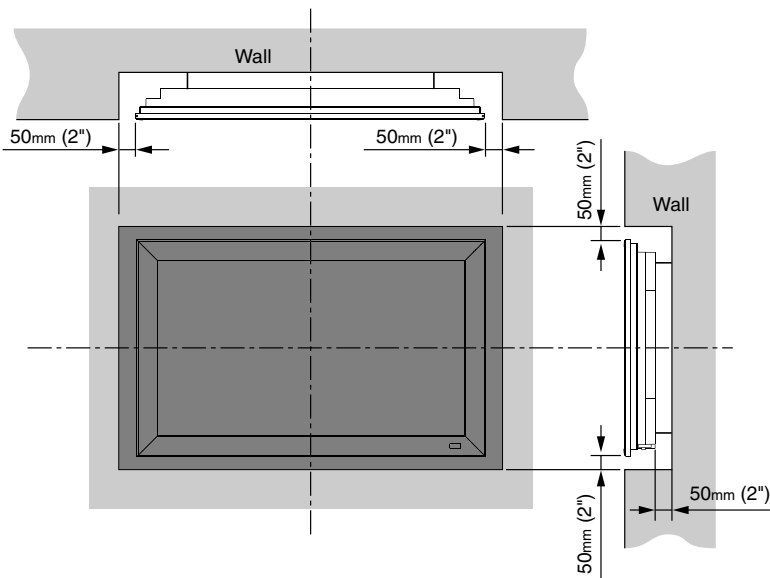

**Figure 3-2. Ventilation Requirements for Enclosure Mounting**

- Other Considerations** ➤ Other considerations and tips that can help improve your installation, avoid damage and prolong operating life:
- Keep the ambient temperature constant and below 35°C (95°F). Keep the display away from heating and/or air conditioning vents. Changes in temperature may cause drifts in the display circuitry, which may affect performance.
  - Keep the PlasmaView VHD away from devices that radiate electromagnetic energy such as motors and transformers. Common sources of these include slide projectors, speakers, power amplifiers and elevators.
  - Handle the unit carefully when installing or carrying it. Use the built-in handles; DO NOT touch or hold the screen face.
  - Set the unit away from heat, excessive dust, and direct sunlight.
  - Protect the inside of the unit from liquids and small metal objects. In case of accident, unplug the power cord and have it serviced by an authorized Service Center.
  - Do not hit or scratch the panel surface as this causes flaws on the surface of the screen.
  - For correct installation and mounting it is strongly recommended to use a trained, authorized dealer.
  - To avoid sulfurization, it is strongly recommended not to place the unit in a dressing room in a public bath or hot spring bath.

Proceed as follows to connect the PlasmaView VHD to the VHD Controller, your video sources, external controller(s) – if present – and AC power.

When connecting your equipment:

- Turn off all equipment before making any connections.
- Use the correct signal cables for each source.
- Ensure that the cables are securely connected. Tighten the thumbscrews on connectors that have them.

Connect the VHD Controller to the PlasmaView VHD as shown in Figure 3-3 and described in the sections that follow.

### 3.4 Connections to the PlasmaView VHD and VHD Controller

#### ◀ Connecting the PlasmaView VHD to the VHD Controller

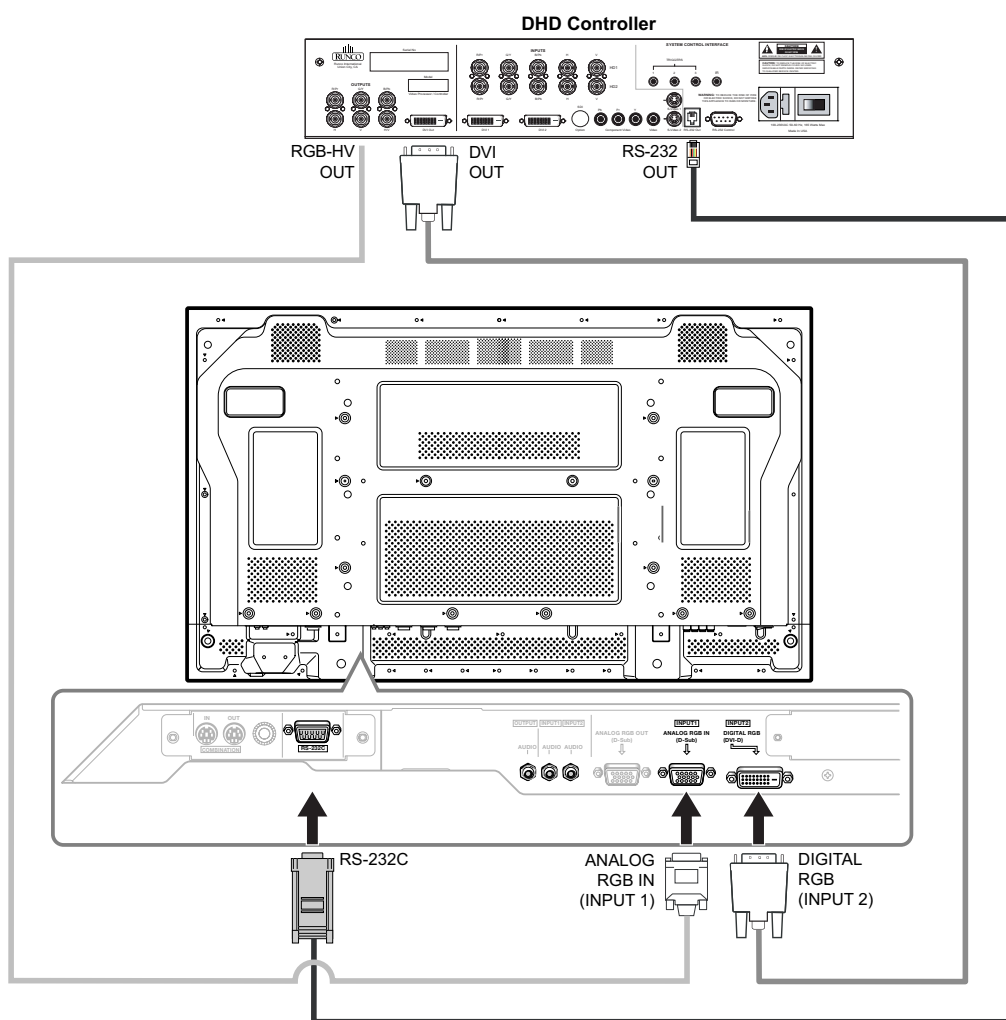
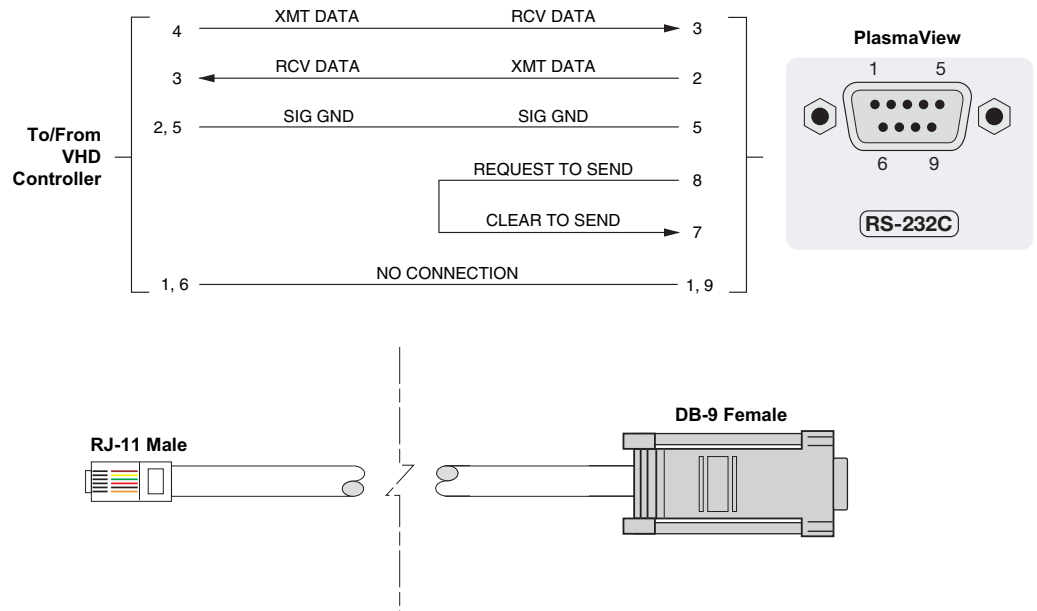

Figure 3-3. Connecting the PlasmaView VHD to the VHD Controller

**Digital Video Connection:** The PlasmaView VHD has a DVI input, labeled **DIGITAL RGB**. Connect the DVI output from the VHD Controller to this input, using a standard DVI cable.

**RGBHV Connection:** Connect the RGBHV output from the VHD Controller to the **ANALOG RGB IN** input on the PlasmaView VHD. Use a standard, RGBHV breakout cable with five BNCs at the controller end and a 15-pin, D-sub male connector at the PlasmaView VHD end.

**RS-232 Connection:** Connect the RS-232 output from the VHD Controller to the **RS-232C** input on the PlasmaView VHD. Use a standard, modular telephone cable with RJ11 plugs at both ends. On the PlasmaView VHD end, use the provided RJ11-to-DB9 adapter. This adapter is wired as shown in Figure 3-4.



**Figure 3-4. RS-232 Connection from the VHD Controller to the PlasmaView VHD**



Connect your video sources to the VHD Controller as shown and described in the sections that follow.

◀ **Connecting Source Components to the VHD Controller**

**DVI Connections:** See Figure 3-5.



**Tip**

Use the DVI inputs whenever possible. This ensures the highest video quality because the signal is carried in the digital domain throughout the entire signal path, from source component output into the display.

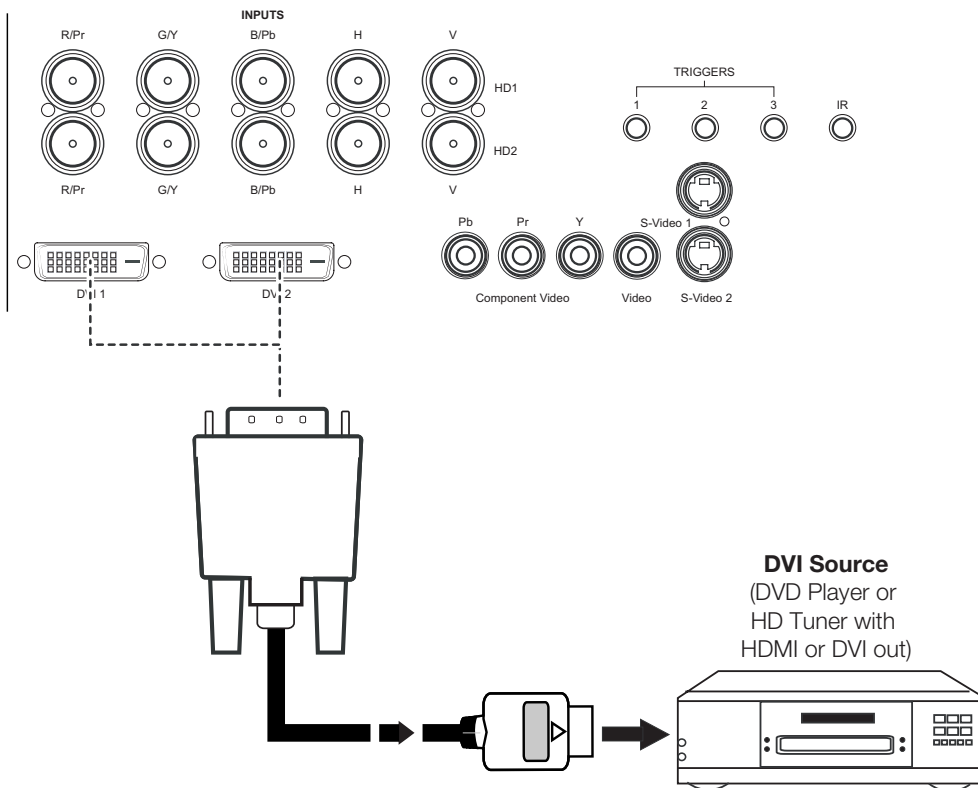

**Figure 3-5. DVI Source Connections**

**Digital (DTV) RGB Connections:** See Figure 3-6.

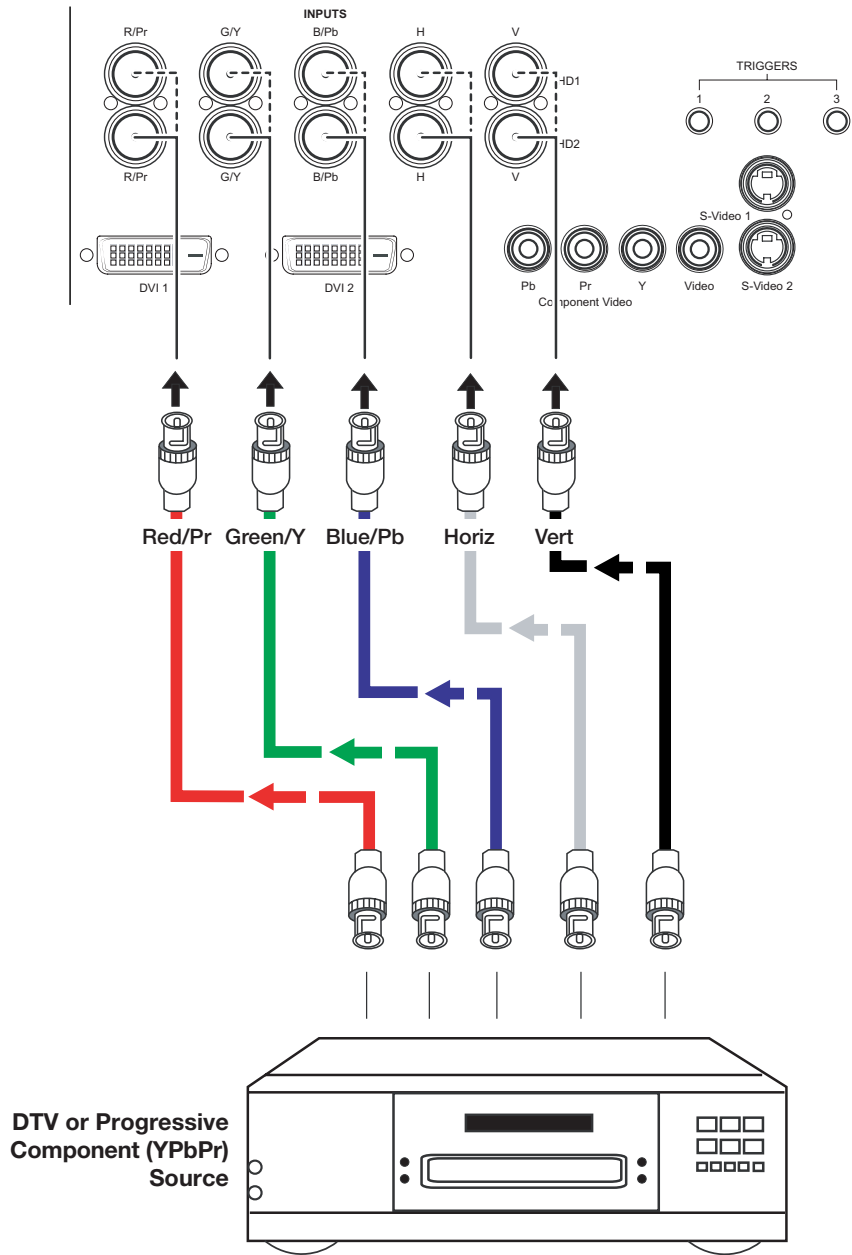

**Figure 3-6. Digital (DTV) RGB Connections**

**Analog (Computer) RGB Connections:** See Figure 3-7.



**Note**

1. Refer to **Computer/Video Signal Compatibility** on page 60 for a list of computer signals compatible with the PlasmaView VHD. Use with signals other than those listed may cause some functions not to work.
2. Some Macintosh computers may require a Macintosh video adapter. Contact your nearest authorized service center or dealer.

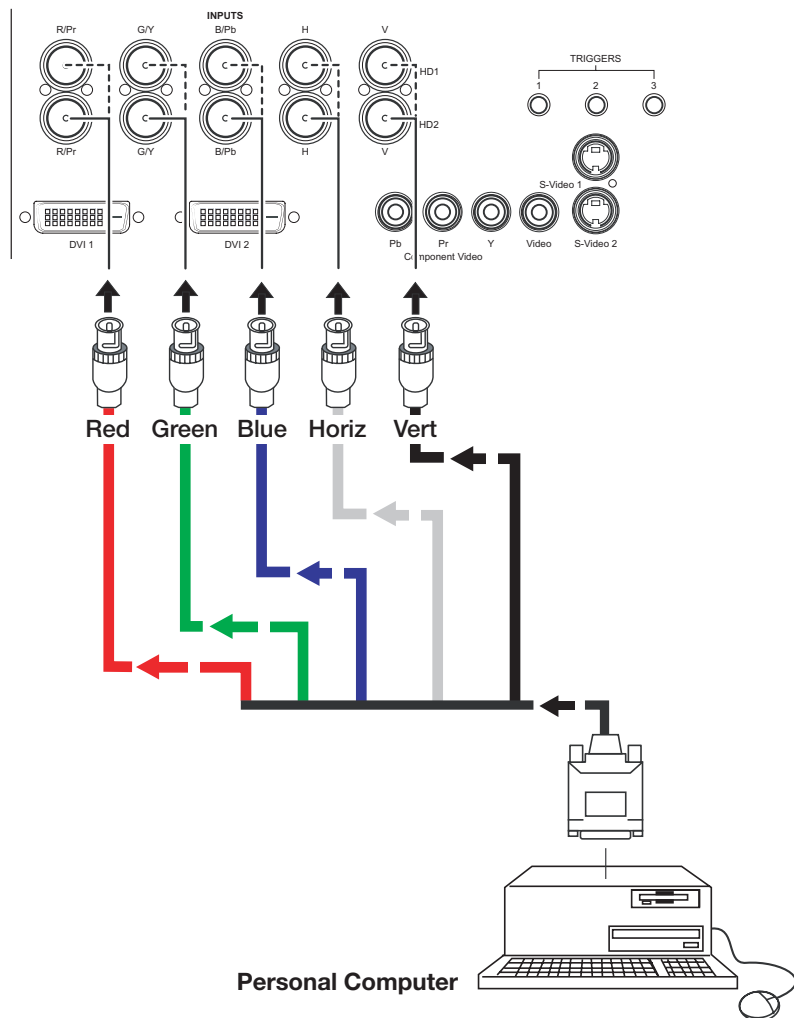

**Figure 3-7. Analog RGB Connections**

**Composite/S-Video/Component Video Connections:** See Figure 3-8.

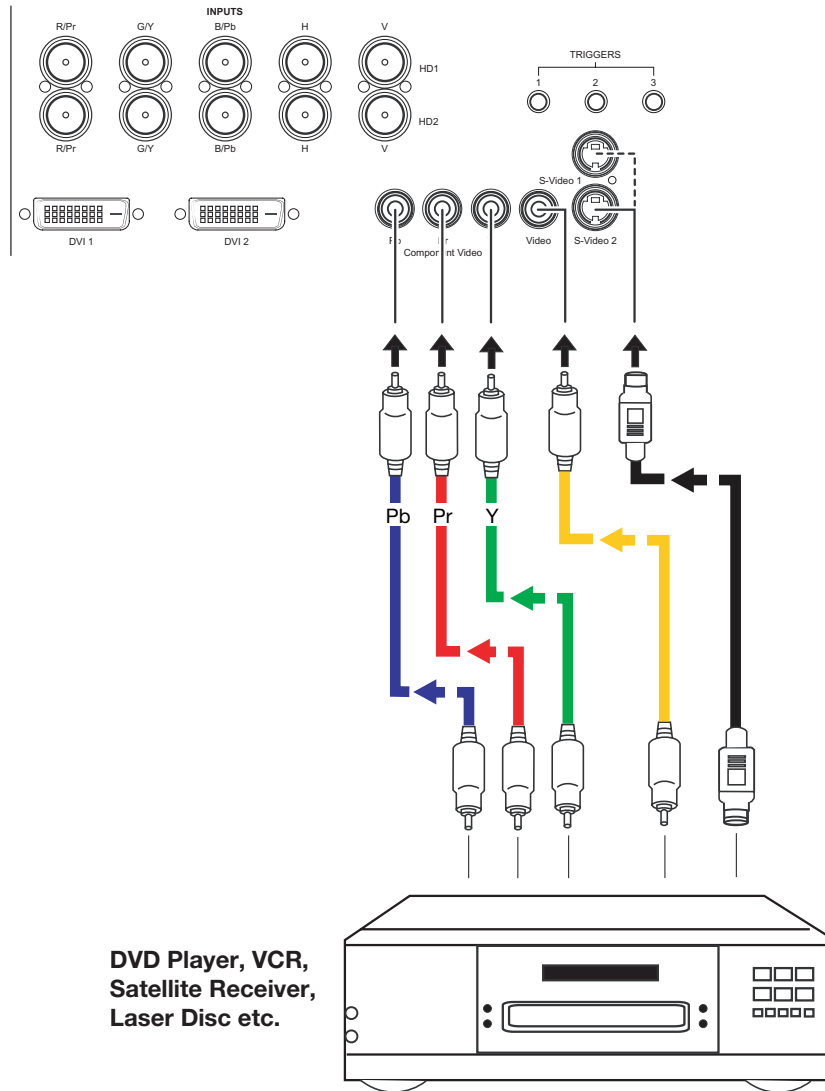
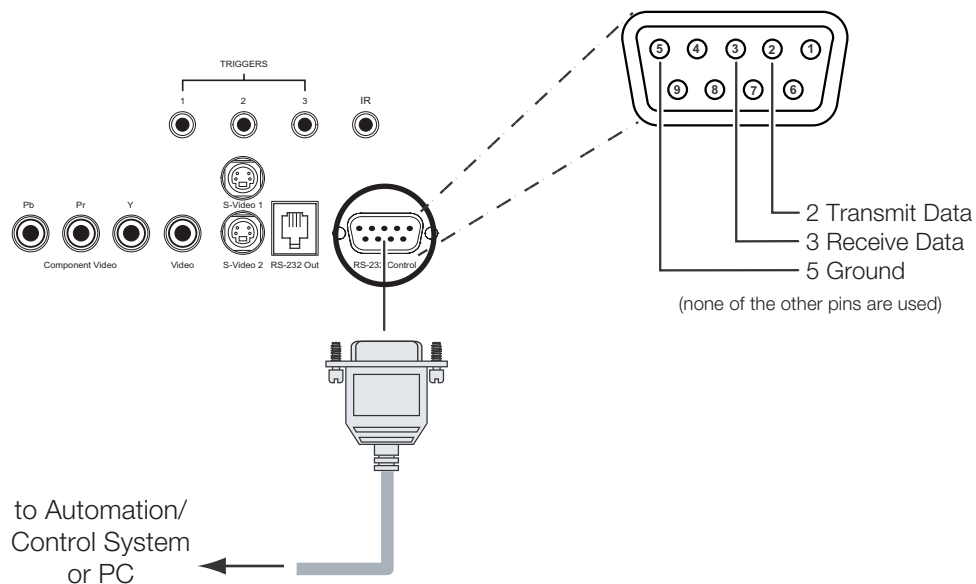

**Figure 3-8. Composite, S-Video and Component Video Connections**

Use a standard, 9-pin RS-232 cable to connect a PC or home theater control/automation system (if present) to the RS-232 Control port on the VHD Controller; see Figure 3-9.

For more information about using this connection, refer to **Serial Communications** on page 51.

◀ **RS-232 Controller Connection**



**Figure 3-9. RS-232 Control System Connection**

If your home theater contains equipment that responds to 12-Volt triggers, connect it to the 12-Volt trigger outputs as shown in Figure 3-10.

◀ **Connecting 12-Volt Trigger Outputs to External Equipment**

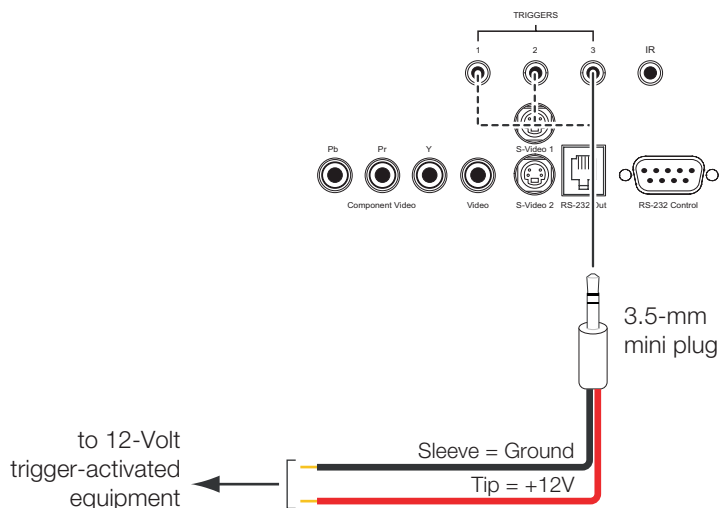

**Figure 3-10. Connecting 12-Volt Trigger Outputs**

**Connecting an External IR Receiver to the VHD Controller**

If infrared signals from the remote control cannot reach the VHD Controller due to excessive distance or obstructions such as walls or cabinet doors, you can connect an external IR receiver to the VHD Controller to extend the range of the remote control. See Figure 3-11.

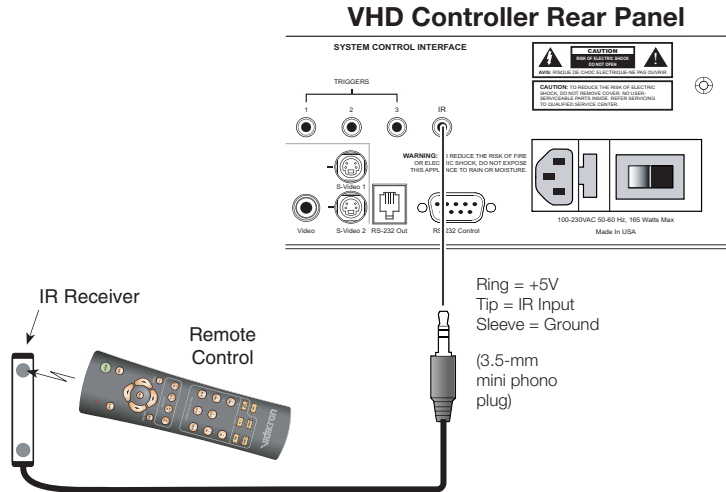

**Figure 3-11. External IR Receiver Connection**



**Note**

When an external IR receiver is connected to the wired IR input, the built-in IR sensor on the VHD Controller is disabled.

**Cable Management**

To minimize cable clutter, you can use the cable ties provided with the PlasmaView VHD to bundle the video, control and power cables at the back of the display. Install the cable ties as shown in Figure 3-12. Cables can be routed to the right or left.



**Note**

Do not allow excessive stress to be placed on the ends of cables.

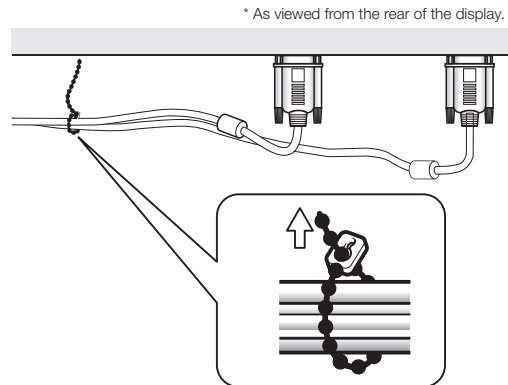

**Figure 3-12. Installing the Cable Ties**

1. Turn on your source components.
2. Plug the female end of the power cord into the AC receptacle on the rear of the PlasmaView VHD. Connect the other end to your AC power source.

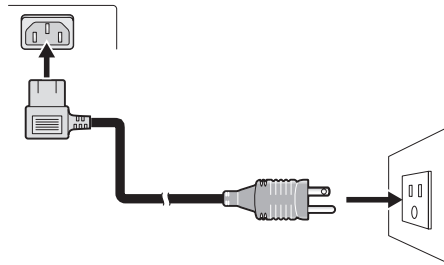

## 4.1 Turning on the Power

3. Similarly connect the VHD Controller to a nearby AC outlet.
4. Set the main power switch at the rear of the PlasmaView VHD (see Figure 2-2) to the "on" position. Its power indicator lights red.
5. Set the main power switch at the rear of the VHD Controller (see Figure 2-4) to the "on" position.
6. Press the **ON** button on the remote control to turn on the VHD Controller and PlasmaView VHD (or press the power button on the front of the VHD Controller). The power indicator on the VHD Controller lights solid blue.
7. After a brief warm-up period (approximately 10 seconds), the PlasmaView VHD will display an image.

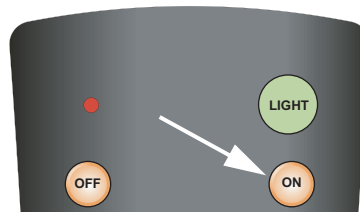

The fluorescent display indicates the active source, signal format (NTSC or PAL), input resolution and aspect ratio; for example:

Current Source	Format	Input Resolution
Component	SD NTSC	480i
Anamorphic		VP-6000
<hr/> Aspect Ratio		

## 4.2 Selecting the Input Source

By default, the PlasmaView VHD is configured to display the signal received on its RGBHV (ANALOG RGB IN) input. To use the DVI-D (DIGITAL RGB) input instead:

1. Press **MENU** and enter the Service Menu passcode.



**Note**

*You must enter a passcode to access the Service menu.*

2. Select **Service** from the Main Menu.
3. Select **Display Device** from the Service Menu.
4. Press **▼** to select DVI/HDMI, then press **ENTER**.

## 4.3 Setting the Computer Display Properties

To maximize image quality when using the PlasmaView VHD with a personal computer, you may need to adjust the display properties of your computer's video card. To do this on a Microsoft® Windows®-based PC:

1. Choose Settings from the Windows Start Menu and click on "Control Panel."

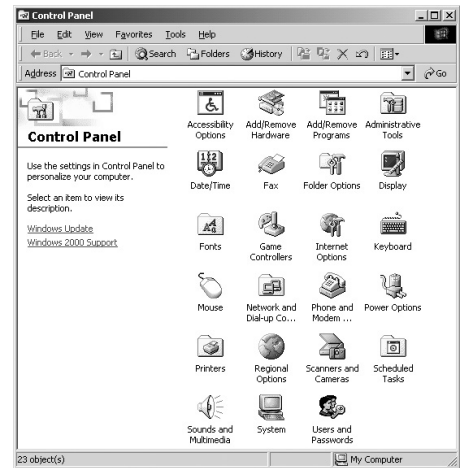

2. Double click on the **Display** icon.
3. Click the **Settings** tab on the display dialog box.
4. Adjust the resolution to 1024x768 pixels.

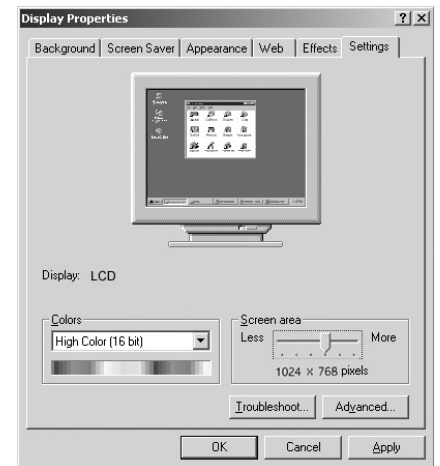

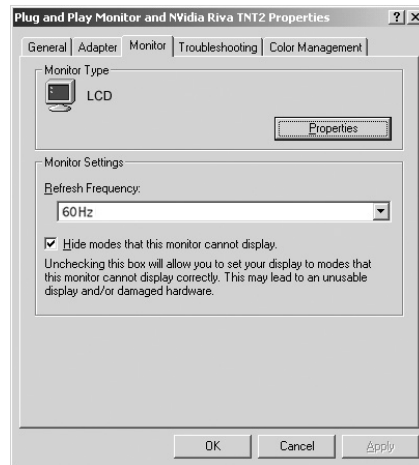

5. Click the **Advanced** button and click the **Monitor** tab on the dialog box. Set the vertical frequency to 60Hz and click **OK**.

**Note**

1. The native resolution of the PlasmaView VHD is 1365 x 768. Other horizontal or vertical resolutions may be scaled upward or downward to fit the display.
2. With most computers, you can get the best picture at 1024 x 768 @ 60Hz.
3. For best results when using a computer, set the input on the VHD Controller to HD1 Pass Thru or HD2 Pass Thru, depending on which RGB/HD input you are using.

**WARNING**

To prevent image retention (burn) on your display, **ALWAYS** use a screen saver and set it to the shortest possible time.

---

#### 4.4 Using the On-Screen Menus

Press the **MENU** button on either the remote control or the VHD Controller front panel to display the Main Menu. To select a menu item, use the UP ( ▲ ) and DOWN ( ▼ ) buttons on either the remote control or the VHD Controller front panel to highlight it. Press **ENTER** to confirm your selection.

The PlasmaView VHD OSD menus are arranged hierarchically, as shown in Figure 4-1. Depending on the selected input source and signal characteristics, some menu options may not be available.

<b>Input Source</b>	Composite
	S Video 1
	S Video 2
	Component SD
	HD/RGB 1
	HD/RGB 2
	DVI 1
	DVI 2
<b>Aspect Ratio</b>	HD1 Pass Thru / HD2 Pass Thru (available only when Display Device Input Source = RGB)
	Anamorphic
	Standard 4:3
	Letterbox
	IntelliWide
<b>Picture</b>	Cinema
	Brightness
	Contrast
	Color
	Tint
<b>Input Position</b>	Sharpness
	Left/Right
	Up/Down
	Width
	Height
<b>ISF Presets</b>	Overscan
	Recall ISF Night
	Recall ISF Day
	Recall/Save Custom 1
	Recall/Save Custom 2
<b>Information</b> (read-only)	Reset Custom 1 & 2 to Factory Default
	Serial Number
	Hardware
	Firmware
	Date

<b>Calibration</b>	ISF Night - Display Color	Gain
		Offset
		ISF Night - Input Image
	Brightness	
	Contrast	
	Color	
	ISF Night - Input Color	Tint
		Sharpness
		Gain
		Offset
	ISF Day - Display Color	Chroma Delay
		Phase
		Noise Filter
		Gain
	ISF Day - Input Image	Offset
		Color Temp. (available only when Display Device Input Source = RGB)
		Brightness
		Contrast
	ISF Day - Input Color	Color
		Tint
Sharpness		
Gain		
ISF Day - Input Color	Offset	
	Chroma Delay	
	Phase	
	Noise Filter	
Save ISF Settings	Back / Confirm	
Output Shift	Left/Right	
	Up/Down	
	Width	
	Height	
	Save	
Splash Configure	Owner Name	
	ISF Calibrated	
	ISF Other	
	Vidikron/ISF Logo Splash Screen Timers (2 ... 60 sec.)	
OSD Position		

<b>Service</b>	Test Video	Grey Bars 1	
		Grey Bars 2	
		Color Bars 1	
		Color Bars 2	
	Input Names	Rename, Restore or Save	
	Remote Control	Primary	
		Secondary	
	Display Device	Input Source	RGB or DVI/HDMI
		Configure	Left/Right
			Up/Down
			Width
	Height		
	HD Format	HD/RGB 1	Auto, RGB or YUV
		HD/RGB 2	
ADC Bandwidth		Auto, 75 MHz, 150 MHz or 300 MHz	
YPbPr Input Resolution		Auto, 480i/p, 576i/p, 720p or 1080i	
Triggers	1 / 2 / 3 / Save		
Miscellaneous	Language	(currently, English only)	
	Menu Mode		
	Timeout		
	Side Bar Color		
System Reset	Film Mode (SD src. only)		
Restore Saved Settings			

Figure 4-1. VHD Controller OSD Menu Structure for PlasmaView VHD

**Main Menu** ➤ The Main Menu is the starting point for accessing all display functions.

(The Calibration and Service menus are hidden and not accessible until you enter a passcode.)

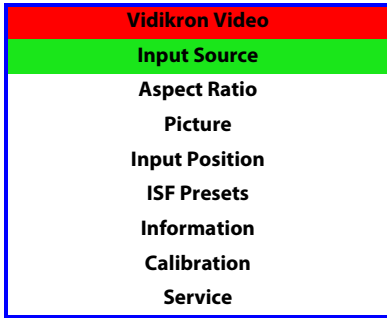

**Input Source** ➤ From the Main Menu, select Input Source to choose a video signal source.

The active source is indicated by an arrow (>) to its left; in the example at left, Composite is the active source.

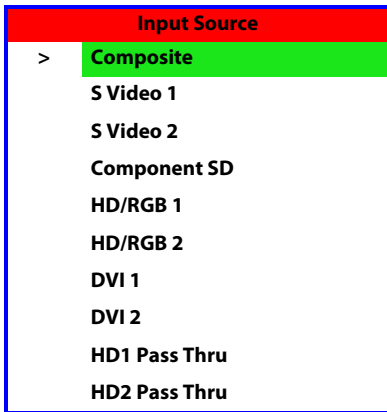

**Note**

1. HD1 Pass Thru and HD2 Pass Thru are available only when the Display Device Input Source is set to **RGB**; refer to **Display Device** on page 44.
2. Selecting HD1 Pass Thru or HD2 Pass Thru loops the HD/RGB 1 or HD/RGB 2 input signal respectively to the RGB output. This prevents display of the on-screen menus. To switch from HD1 Pass Thru or 2 to another source, use the direct access buttons on the remote control, or the left- or right-arrow buttons on the VHD Controller.
3. If the DVI 1 or DVI 2 input is active and the input signal is HDCP-encrypted, the RGBHV output of the VHD Controller is disabled.

**Aspect Ratio** ➤ To change the aspect ratio (size and shape) of the projected image, select Aspect Ratio from the Main Menu and press **ENTER**. Select the appropriate aspect ratio for your screen size and the type of program material being viewed; refer to Table 4-1.

The currently-selected aspect ratio is indicated by a "☒" to its left; in the example at left, Anamorphic is selected.

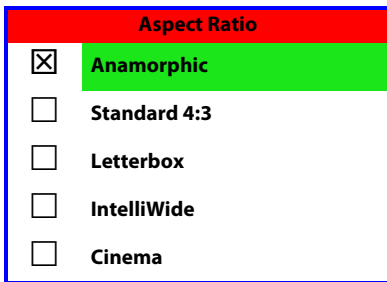

**Note**

The aspect ratio selection is automatically saved for each input and resolution.

**Table 4-1. Aspect Ratio Settings**

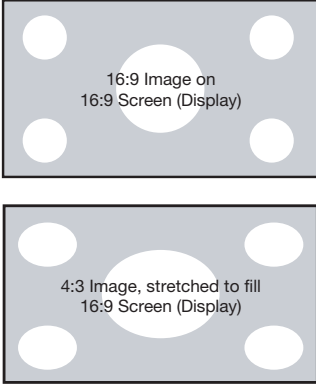
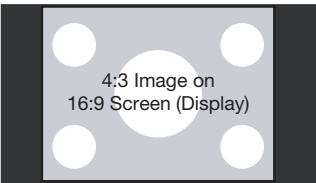
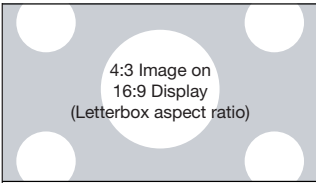
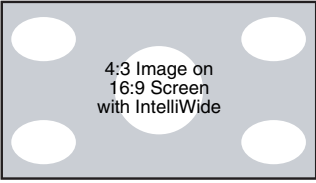
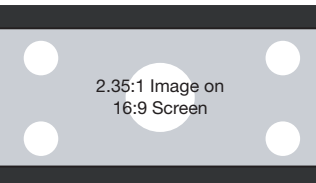
Aspect Ratio	Remote Control Key	Description	
16:9 (Anamorphic)	ANA	 <p>16:9 Image on 16:9 Screen (Display)</p> <p>4:3 Image, stretched to fill 16:9 Screen (Display)</p>	<p>Select 16:9 (Anamorphic) to view 16:9 DVDs and HDTV programs in their native aspect ratio.</p> <p>4:3 images are stretched horizontally to fit a 16:9 screen.</p>
Standard 4:3	4X3	 <p>4:3 Image on 16:9 Screen (Display)</p>	<p>Standard 4:3 scales the input signal to fit in the center of the 16:9 screen. 4:3 is the aspect ratio used by computer monitors, standard television programming and most VHS video cassettes.</p>
Letterbox	LET BOX	 <p>4:3 Image on 16:9 Display (Letterbox aspect ratio)</p>	<p>Letterbox mode scales (zooms in on) a 4:3 image linearly (by the same amount on all sides) to fill a 16:9 display. Letterbox is best suited for viewing LaserDisc movies or non-anamorphic DVDs on a 16:9 screen.</p>
IntelliWide	I-WIDE	 <p>4:3 Image on 16:9 Screen with IntelliWide</p>	<p>IntelliWide scales a 4:3 image NON-linearly (more on the sides than in the center) to fit a 16:9 screen.</p>
Cinema	CINEMA	 <p>2.35:1 Image on 16:9 Screen</p>	<p>Select Cinema to view 2.35:1 source material on a 16:9 screen. The upper and lower portions of the screen are masked, but the geometry of the active image area is not changed.</p>

**Picture** ➤

<b>Picture</b>
<b>Brightness</b>
<b>Contrast</b>
<b>Color</b>
<b>Tint</b>
<b>Sharpness</b>

Use the controls in the Picture Menu to calibrate your PlasmaView VHD for optimum picture quality.

The PlasmaView VHD has been designed to incorporate setup and calibration standards established by the Imaging Science Foundation (ISF). The ISF has developed carefully crafted, industry-recognized standards for optimal video performance and has implemented a training program for technicians and installers to use these standards to obtain optimal picture quality from Vidikron video display devices. Accordingly, Vidikron recommends that setup and calibration be performed by an ISF-certified installation technician.

All signal types require separate processing. Therefore, you need to calibrate each VHD Controller input separately.



**Note**

*When you change a picture quality setting, save the change to a preset afterwards. Otherwise, the change will be lost when a different input is selected. (Picture quality settings are saved for each input separately.) For information about saving settings, refer to **ISF Presets** on page 40.*

Although it may be possible to obtain satisfactory picture quality using the naked eye and regular program material, Vidikron recommends using the following calibration tools for best results:

- External test pattern source – Ovation Multimedia, Video Essentials or AVIA test DVD (or equivalent).
- A blue filter (provided with many test DVDs), for color level and tint adjustments.

Connect your test pattern source to the input that you are calibrating and proceed as follows. **Perform the adjustments in the order listed here.**

**Brightness:** On your external test pattern source, select a PLUGE pattern. (PLUGE is an acronym for “Picture Line-Up Generation Equipment.”) Figure 4-2 shows a typical PLUGE pattern.

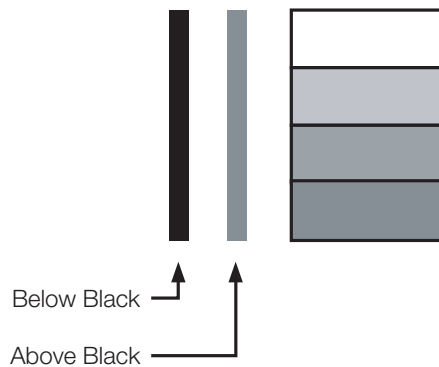

**Figure 4-2. Typical PLUGE Pattern for Adjusting Brightness**

PLUGE patterns vary but generally consist of some combination of black, white and gray areas against a black background. The example above includes two vertical bars and four shaded boxes.

Select Brightness from the Picture menu and press **ENTER**. Adjust the brightness so that:

- The darkest black bars disappear into the background.
- The dark gray areas are barely visible.
- The lighter gray areas are clearly visible.
- The white areas are a comfortable level of true white.
- The image contains only black, gray and white (no color).

**Contrast:** On your external test pattern source, select a stepped, gray-bar pattern like the one shown in Figure 4-3.



**Figure 4-3. Typical Gray Bar Pattern for Adjusting Contrast**

Select Contrast and press **ENTER**. Adjust the contrast to a point just below which the white rectangle starts to increase in size.



**Note**

*Brightness and contrast controls are interactive. A change to one may require a subtle change to the other in order to achieve the optimum setting.*

**Color Saturation:** On your external test pattern source, select a color bar pattern like the one shown in Figure 4-4.

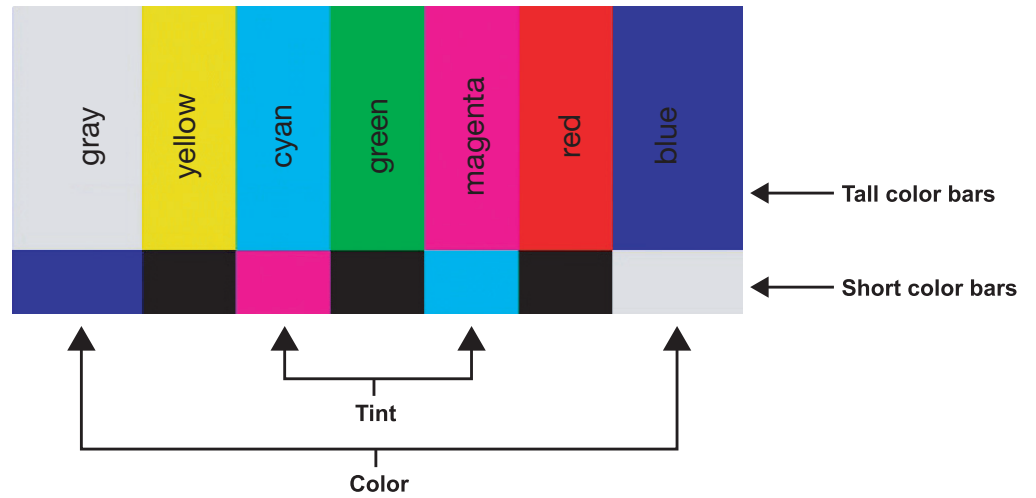

**Figure 4-4. Typical Color Bar Pattern for Adjusting Color Saturation and Tint**

Select Color and press **ENTER**. While looking at the color bar pattern through a blue filter, adjust the color saturation level until the outermost (gray and blue) color bars appear to be a single shade of blue:

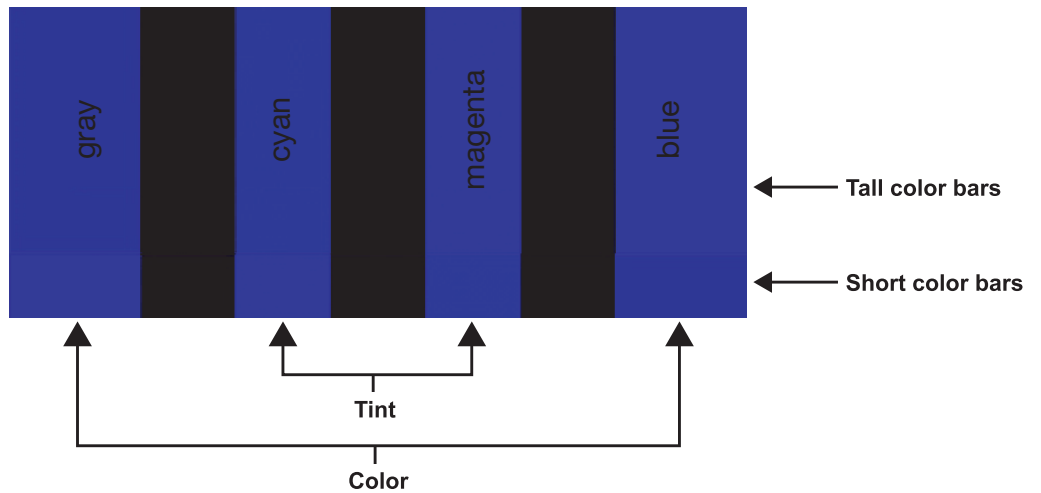

**Tint:** Tint or “hue” is essentially the ratio of red to green in the color portion of the image. When tint is decreased, the image appears redder; when it is increased the image appears greener. To set the tint, select Tint and press **ENTER**. While looking at the color bar pattern through a blue filter, adjust the tint level until the cyan and magenta color bars (on either side of the green bar) appear to be a single shade of blue.



**Note**

*Like the brightness and contrast controls, the color and tint controls are interactive. A change to one may require a subtle change to the other in order to achieve the optimum setting.*



**Sharpness:** “Sharpness” is the amount of high-frequency detail in the image. To adjust sharpness, select Sharpness from the Picture menu and press **ENTER**. On your external test pattern source, select a pattern like the one shown in Figure 4-5. Adjust as needed, looking for white edges around the transitions from black to gray and differently-sized lines in the “sweep” patterns at the top and bottom. Lower the sharpness setting to eliminate them.

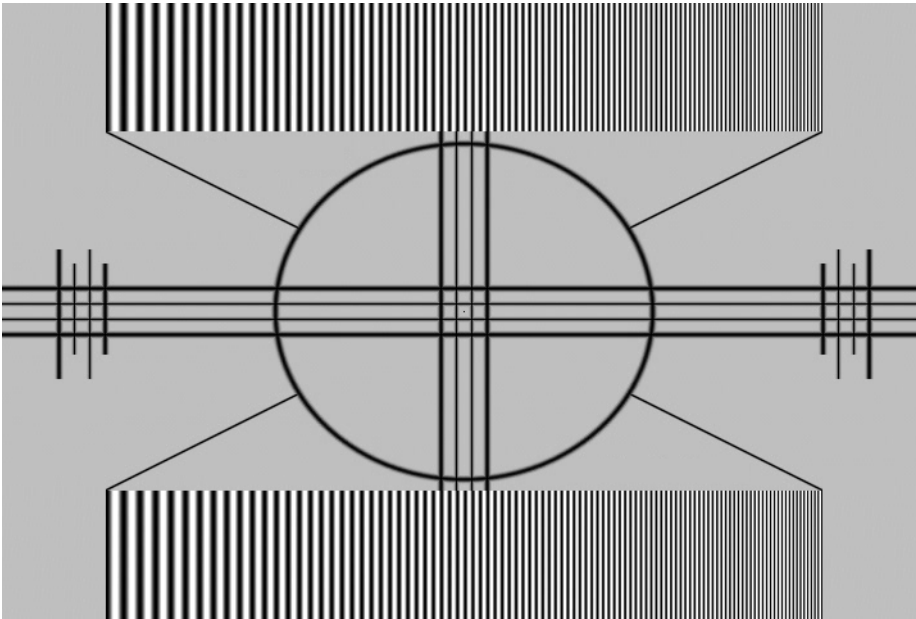

**Figure 4-5. Typical Test Pattern for Adjusting Sharpness**

Use the controls in the Input Position Menu to fine-tune the aspect ratio and image position for the current source.

◀ **Input Position**

<b>Input Position</b>
<b>Left/Right</b>
<b>Up/Down</b>
<b>Width</b>
<b>Height</b>
<b>Overscan</b>



**Note**

*The input position settings are automatically saved for each input and resolution.*

**Left/Right:** Select Left/Right from the Input Position menu to shift the projected image horizontally. Use the right or up cursor button to shift the image to the right; use the left or down button to shift it to the left.

**Up/Down:** Select Up/Down from the Input Position menu to shift the projected image vertically. Use the right or up cursor button to shift the image upward; use the left or down button to shift it downward.

**Width:** Select Width from the Input Position menu to change the projected image width. Use the right or up cursor button to increase the width; use the left or down button to decrease it.

**Height:** Select Height from the Input Position menu to change the projected image height. Use the right or up cursor button to increase the height; use the left or down button to decrease it.

**Overscan:** Image Overscan pushes the outside edge of the active picture area of the video signal out beyond the edge of the display area.

Some television programs are produced based on the assumption that older television sets may not display the outer edges of the broadcast picture area. Over scan effectively trims away these inactive, outer edges and enlarges the remaining portion of the image to fill the display area.

Select from 1% to 10% of Overscan, as desired.

For HDTV, DVDs and other video sources, Overscan is generally not necessary or desirable.

**ISF Presets** ➤

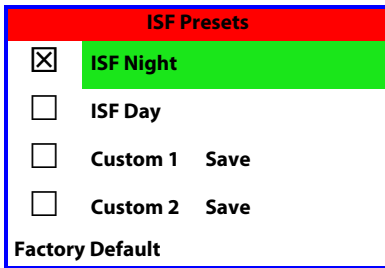

For each input, the PlasmaView VHD lets you save image quality settings as presets that you can recall at a later time. You can create up to four presets per input and resolution. Use the ISF Presets menu to recall saved image presets, or to save image settings in the “Custom 1” or “Custom 2” memory location. The currently-selected preset is indicated by a “☒” to its left; in the example shown here, ISF Night is selected.

You should save changes to any of the following settings to a preset; otherwise they will be lost when a new input source or resolution is selected:

- Brightness
- Contrast
- Color saturation
- Tint
- Sharpness

To reset the Custom 1 and Custom 2 image presets to their factory defaults, select Factory Default and press **ENTER**.

**Information** ➤

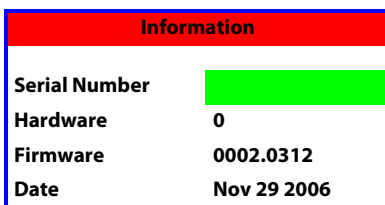

Select Information from the Main Menu to see information that uniquely identifies your display: its serial number, the installed hardware and firmware versions and the firmware version build date. Should you ever need to contact Vidikron Technical Support, this information will help them answer your questions or resolve product performance issues.

Use the Calibration menu to perform advanced picture quality adjustments. **This menu should be used by ISF-certified technicians only.**

◀ Calibration



**Note**

*You must enter a passcode to access the Calibration menu.*

To recall the ISF Night or ISF Day settings, select “ISF Night” or “ISF Day” from the ISF Presets menu (see above). Or, use the corresponding buttons on the remote control.

**ISF Night - Display Color:** Use the Display Color settings to adjust the color balance at the display device (as opposed to the VHD Controller). These settings are saved independently for each input.

- **Gain:** Use the Gain controls to correct color imbalances in the bright areas of the image. A good way to do this is to use a test pattern consisting mostly of solid white areas, such as an 80 IRE “window” pattern. If the white areas contain traces of red, green or blue, decrease the Gain for that color.
- **Offset:** Use the Offset controls in the White Balance sub-menu to correct color imbalances in the dark areas of the image. A good way to do this is to use a test pattern consisting mostly of dark gray areas, such as a 30 IRE “window” pattern. If the gray areas contain traces of red, green or blue, decrease the Offset for that color.
- **Color Temp (RGB Display Device only):** Select Color Temp from the Display Color menu to adjust the color temperature. The default setting is appropriate for most situations. Higher settings produce a “bluer” picture.

**ISF Night - Input Image:** The Input Image controls are similar to those in the Picture menu, but are accessible only by entering the Calibration menu passcode. This makes it possible to restore the picture quality settings to what they were when the display was installed, simply by recalling the “ISF Night” preset.

**ISF Night - Input Color:** The Input Color controls are similar to those in the Display Color menu (see above), but adjust the color balance at the VHD Controller (as opposed to the display device). These settings are also saved independently for each input.

- **Gain/Offset:** Refer to **ISF Night - Display Color**, above.
- **Chroma Delay:** use the Chroma Delay control to correct a mis-aligned image from a Composite, S-Video or Component video source. Chroma delay in an image causes color shifts to occur to the left of the vertical edge transitions, producing artificial shadows or a “halo” effect. If necessary, adjust this setting to eliminate them.
- **Phase:** Adjust the phase if the image (usually from an RGB source) shows shimmer or “noise.” Pixel phase adjusts the phase of the pixel sampling clock relative to the incoming signal. The effect of this control is similar to that of a tracking control on a VCR.

For best results, use a good test pattern such as a smooth gray consisting of a clear pattern of black and white pixels, or a similar “half on, half off” graphic image. (You may notice that you can stabilize the image at more than one point. Use either setting in this case.)

Calibration
<b>ISF Night</b>
<b>Display Color</b>
Input Image
Input Color
<b>ISF Day</b>
Display Color
Input Image
Input Color
Save ISF Settings
Output Shift
Splash Configure
OSD Position

- **Noise Filter:** To apply noise filtering to the input signal, select Noise Filter from the Input Color menu. The Noise Filter is useful for clearing up noisy images from 480i video sources.

Use the left- or right-arrow buttons to select the desired amount of noise reduction, keeping in mind that higher settings (which reduce high frequencies) may also “soften” the image.

**ISF Day - Display Color:** Refer to *ISF Night - Display Color*.

**ISF Day - Input Image:** Refer to *ISF Night - Input Image*.

**ISF Day - Input Color:** Refer to *ISF Night - Input Color*.

**Save ISF Settings:** Whenever you make a change to the ISF settings, you should always save it. Select Save ISF Settings from the ISF Calibration menu to do this. In the event you ever have to perform a System Reset, you can restore the saved ISF settings by selecting Restore Saved Settings in the Service menu. (System Reset and Restore Saved Settings are described on page 45.)

**Output Shift:** The controls in the Output Shift menu are similar to those in the Input Position menu, except that they change the characteristics of the output signal. These settings are saved independently **for each aspect ratio**.

**Splash Configure:** Use the Splash Configure menu to customize the appearance of the start-up message that appears on the vacuum fluorescent display upon power-up.

- **Owner Name/ISF Calibrated/ISF Other:** You can have the PlasmaView VHD display the owner’s name, your name, the phrase “ISF Calibrated” and/or any other string, up to 20 characters in length.

Use the up or down cursor button to select a character. Use the right and left cursor buttons to change the cursor position. Press **MENU** when you have finished entering text. Then, check the “Splash Enable” box to have the PlasmaView VHD display the information you enter here when it is turned on.

- **Vidikron/ISF Logo Splash Screen Timers:** When you turn on the PlasmaView VHD, it projects a welcome screen with the Vidikron logo followed by one with the ISF logo. Select Splash Timer from the Splash Configure menu to set the amount of time that these two images appear. The range is from 2 to 60 seconds, in one-second increments.

Use the up or down cursor button to select a timer value to adjust. Use the right or left cursor button to change the timer value. Press **MENU** when you have finished configuring both timers.

**OSD Position:** Select OSD Position, press **ENTER** and use the arrow buttons to change the size and position of the OSD controls.

Use the Service menu to access advanced display configuration settings. **This menu should be used by ISF-certified technicians only.**

◀ **Service**



**Note**

*You must enter a passcode to access the Service menu.*

**Test Video:** Select Test Video from the Service Menu to access the internal test patterns on the PlasmaView VHD. Four patterns are available, consisting of white/gray or colored bars. These are useful for calibrating other theater source components (DVD player, HD tuner etc.) that have their own picture controls.

Press **MENU** to exit test pattern mode.

**Input Names:** You can give each VHD Controller input a descriptive name. For example, you may want to change the default input name to the type of source component connected to it: "VCR," "DVD," "Laptop" et cetera. Composite, S-Video and Component SD input names can be up to 12 characters long; the others can be up to eight characters long.

To edit an input name, select Input Names from the Service menu. Press ▲ or ▼ to select an input and press **ENTER**. Use the ▲ or ▼ buttons to change a character; press ◀ or ▶ to select a character to change. When you have finished editing the input name, press **MENU**.

To restore the default input name, press ▼ repeatedly to highlight that input name in the "Restore" column. Then, press **ENTER**.

To save input names so that they can be restored after a System Reset (described on page 45), press ▼ repeatedly to highlight "Save." Then, press **ENTER**.

<b>Service</b>
<b>Test Video</b>
<b>Input Names</b>
<b>Remote Control</b>
<b>Display Device</b>
<b>HD Format</b>
<b>Triggers</b>
<b>Miscellaneous</b>
<b>System Reset</b>
<b>Restore Saved Settings</b>

<b>Input Names</b>	
	<b>Restore</b>
<b>Composite</b>	<b>Composite</b>
<b>S Video 1</b>	<b>S Video 1</b>
<b>S Video 2</b>	<b>S Video 2</b>
<b>Component SD</b>	<b>Component SD</b>
<b>HD/RGB 1</b>	<b>HD/RGB 1</b>
<b>HD/RGB 2</b>	<b>HD/RGB 2</b>
<b>DVI 1</b>	<b>DVI 1</b>
<b>DVI 2</b>	<b>DVI 2</b>
<b>Save</b>	



**Note**

*The ▼ button takes you from top to bottom in the left column, then from top to bottom in the right column. To highlight "Save," scroll through both columns.*

**Remote Control:** The Remote Control menu shows you the primary and secondary infrared (IR) codes to which the VHD Controller will respond. By default, both are set to 17. You can change these codes if either:

- Another device in the theater (a DVD player, for example) is responding to commands from the VHD Controller remote control (Figure 2-5) in ways that are unpredictable or undesirable.
- You have multiple VHD Controllers and want to control them independently, as opposed to broadcasting commands from a single remote to all of them. In this scenario, you can use multiple remotes programmed to use different IR codes. Or, you can use a single remote and change the IR code as needed to address a specific device.



**Tip**

*Use the VHD Controller front-panel keypad to change its IR code. Then, change the code sent by the remote to match as described below.*



**Note**

*Do not change the "Type" setting in this menu.*

When you change a remote code on the VHD Controller, you must re-program your remote control to send that same code. To do this:

1. Using a straightened paper clip or similar object, press and hold the **CODE** button on the remote control for approximately three seconds, or until the red LED on the remote lights solid red.
2. Enter a new two-digit code between 00 and 31 inclusive. Include a leading zero for single-digit codes; for example, enter 9 as "09."
3. The LED turns off to confirm the code change. If you enter an invalid code, the LED flashes for three or four seconds. Try again, entering a valid code.

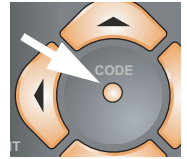

**Display Device:** The options in the Display Device menu allow you to perform certain adjustments at the plasma display.

- **Input Source:** Select **Input Source** from the Display Device menu to switch from one VHD Controller output/PlasmaView VHD input to the other. Use the ▲ or ▼ button to select **RGB** or **DVI/HDMI**, then press **ENTER**.



**Note**

*If the DVI 1 or DVI 2 VHD Controller input is active and the input signal is HDCP-encrypted, the RGBHV output of the VHD Controller is disabled.*



**Tip**

*Use the serial command `DISPLAY 1` or `DISPLAY 2` to set the Input Source to RGB or DVI/HDMI respectively, so that the VHD Controller retains this setting after a System Reset. (This is not the case when you change the Input Source in the Display Device menu.) For more information, refer to **Miscellaneous Commands** on page 55.*

- **Configure:** Select Configure from the Display Device menu to perform the following display device adjustments (these are global, independent of any input):
  - Select **Left/Right** or **Up/Down** and use the ◀ or ▶ buttons to fine-tune the displayed image position.
  - Select **Width** or **Height** and use the ◀ or ▶ buttons to fine-tune the display device aspect ratio.

**HD Format:** If the characteristics of the incoming signal on the HD1 or HD2 inputs are known, select HD Format from the Service menu and set them as described below. Doing so can reduce the time it takes the VHD Controller to switch from HD to 480i signals or vice versa.

This is generally not necessary unless the VHD Controller – for whatever reason – has difficulty determining the color space (RGB or YUV), bandwidth or resolution of the incoming HD signal. In most situations, the **Auto** settings work well.

- **HD/RGB 1 and HD/RGB 2 (Color Space):** Select Auto, RGB or YUV.
- **ADC Bandwidth:** Select Auto, 75 MHz, 150 MHz or 300 MHz.
- **YPbPr Input Resolution:** Select Auto or specify the input resolution, if known: 480i, 480p, 576i, 576p, 720p or 1080i.

**Triggers:** Select Triggers from the Service menu to configure the 12-volt trigger outputs. You can assign one or more trigger outputs to each aspect ratio. Those triggers are then activated by selecting that aspect ratio.

To save the trigger settings so that they can be restored after a System Reset (described below), press ▼ repeatedly to highlight "Save." Then, press **ENTER**.

**Miscellaneous:** Select Miscellaneous from the Service menu to set the following options:

- **Language:** Select Language from the Miscellaneous menu and press the up- or down-arrows to select the OSD language. (Currently, only English is supported.)
- **Menu Mode:** This is the manner in which the OSD menus appear and disappear when you press **MENU**. Choose one of the following:
  - 0 = No transition; menus abruptly appear and disappear.
  - 1 = Menus fade in and out.
  - 2 = "Checkerboard" dissolve; menus appear and disappear in sections.
  - 3 = "Window shade" effect; menus are drawn on a diagonal from top left to bottom right, and retract in the opposite direction.
- **Timeout - Short/Long:** These settings control how long the OSD menus stay on screen. Select a time-out period of from 2 to 60 seconds.
- **Side Bar Color:** This controls the color of the inactive image area. The range is from -100 (black) to 100 (white).

The inactive image area is on either side of the active image area when using the Standard 4:3 aspect ratio (or the entire screen when no incoming video signal is present).

- **Film Mode:** Enable Film Mode to smooth out moving images from interlaced, standard-definition (SD) sources. In most cases, the PlasmaView VHD detects the proper "pull-down" rate and vertical frequency. However, if your source is jittery and/or tearing you may wish to enable Film Mode to ensure stable processing for that source.

**System Reset:** To reset ALL VHD Controller settings (including image settings) back to their factory defaults, choose System Reset from the Service menu.

A confirmation message appears, reminding you to save your settings before you perform the reset, so that you can restore them afterwards. If you have done this, select Confirm to continue with the reset. Otherwise, click Back to cancel.



**Caution**

***This action is not undoable. Proceed with caution!*** Before you perform a System Reset, save ALL settings, including "Custom" ISF Presets (page 40), ISF Day/Night presets (page 40), Output Shift settings (page 42), Input Names (page 43) and Trigger settings (page 44).

**Restore Saved Settings:** Following a System Reset, select Restore Saved Settings to apply all previously-saved settings to the PlasmaView VHD and VHD Controller.

**Notes:**



## Maintenance and Troubleshooting

Regular cleaning will extend the life and performance of the PlasmaView VHD. Before cleaning, be sure to unplug the power cord from the power outlet.

Do not under any circumstances use solvents such as benzene or thinner to clean the PlasmaView VHD. Doing so may cause deterioration or peeling of paint from the display or remote control unit.

Wipe the display and remote control gently with a soft cloth. In the case of excessive dirt buildup, dampen a soft cloth with a diluted neutral cleaning detergent and after wringing the cloth thoroughly, wipe the component and then dry it with a dry soft cloth.

After dusting, wipe the screen gently using the supplied cleaning cloth or another soft cloth (cotton, flannel etc.). Do not use tissue or a rough cloth. The screen surface is easily scratched; do not rub it or hit it with a hard object.

If you clean the surface of the screen with a wet cloth, water droplets on the surface may enter into the product and cause a malfunction.

As a general rule, use a vacuum cleaner about once a month to clean the vents on the rear panel of the display of dust buildup (set the vacuum cleaner to its weakest setting when doing this). If not removed, accumulated dust can cause the internal temperature to increase, resulting in possible breakdown or fire.

---

### 5.1 Cleaning

#### ◀ *Cleaning the Display Panel Body and Remote Control*

#### ◀ *Cleaning the Screen*

#### ◀ *Cleaning the Vents*

## 5.2 Troubleshooting Tips

Table 5-1 provides some general guidelines for troubleshooting problems you may encounter with the PlasmaView VHD. If the suggested solutions fail to resolve the problem or if you encounter an issue not described here, please contact your Vidikron dealer or Vidikron Technical Support.

**Table 5-1. Troubleshooting Chart**

Symptom	Possible Cause(s)	Solution
The display does not turn on after initial installation.	<ul style="list-style-type: none"> <li>The PlasmaView VHD is not plugged in or the AC outlet is not active.</li> <li>The VHD Controller is not plugged in or the AC outlet is not active.</li> <li>The remote control batteries have run out.</li> <li>The serial connection from the VHD Controller to the PlasmaView VHD is incorrect.</li> </ul>	<ul style="list-style-type: none"> <li>Ensure that the PlasmaView VHD is plugged in and that the AC outlet is active.</li> <li>Ensure that the VHD Controller is plugged in and that the AC outlet is active.</li> <li>Replace the batteries.</li> <li>Ensure that the RS-232 output from the VHD Controller is properly connected to the RS-232C input on the PlasmaView VHD (see Figure 3-3).</li> </ul>
The PlasmaView VHD and VHD Controller are both on, but there is no picture and on-screen menus do not appear.	<ul style="list-style-type: none"> <li>Faulty or incorrect video connection between the VHD Controller and the PlasmaView VHD.</li> <li>Incorrect input source selection.</li> <li>Display Device input source is set to RGB, VHD Controller input is set to DVI 1 or DVI 2 and DVI source is HDCP-encrypted.</li> </ul>	<ul style="list-style-type: none"> <li>Ensure that the DVI and/or RGBHV outputs from the VHD Controller are properly connected to the video inputs on the PlasmaView VHD (see Figure 3-3).</li> <li>Choose the correct input source on the display (refer to <b>Selecting the Input Source</b> on page 30).</li> <li>Set the Display Device input source to DVI/HDMI or use a different input on the VHD Controller for the encrypted source material.</li> </ul>
The display is on and menus appear, but there is no picture.	<ul style="list-style-type: none"> <li>Incorrect source selection.</li> <li>Source component is not turned on.</li> <li>Source component is connected incorrectly or not at all.</li> </ul>	<ul style="list-style-type: none"> <li>Select the correct source.</li> <li>Turn on the source component.</li> <li>Check connections from source component to VHD Controller.</li> </ul>
Image is too bright and/or lacks definition in the bright areas of the image.	<ul style="list-style-type: none"> <li>Contrast is set too high.</li> </ul>	<ul style="list-style-type: none"> <li>Lower the contrast setting.</li> </ul>
Image appears "washed out" and/or dark areas appear too bright.	<ul style="list-style-type: none"> <li>Brightness is set too high.</li> </ul>	<ul style="list-style-type: none"> <li>Lower the brightness setting.</li> </ul>

**Table 5-1. Troubleshooting Chart (continued)**

<b>Symptom</b>	<b>Possible Cause(s)</b>	<b>Solution</b>
Colors in the image are swapped; for example, reds appear blue or vice versa.	<ul style="list-style-type: none"> <li>The Red/Pr, Green/Y or Blue/Pb outputs from the source are connected to the wrong inputs on the VHD Controller.</li> <li>The Red, Green or Blue (analog) outputs from the VHD Controller are connected to the wrong inputs on the PlasmaView VHD.</li> </ul>	<ul style="list-style-type: none"> <li>Ensure that the source outputs are connected to the correct VHD Controller input.</li> <li>Ensure that the VHD Controller outputs are connected to the correct inputs on the PlasmaView VHD.</li> </ul>
RGB-HD images appear "noisy."	<ul style="list-style-type: none"> <li>Clock and Phase settings need adjustment.</li> </ul>	<ul style="list-style-type: none"> <li>Adjust Clock and Phase settings (refer to <b>ISF Night - Display Color</b> on page 41).</li> </ul>
"Out of range" appears on-screen.	<ul style="list-style-type: none"> <li>The resolution and frequency of the video card in the computer are not compatible with the PlasmaView VHD.</li> </ul>	<ul style="list-style-type: none"> <li>Select a compatible resolution and vertical frequency (refer to <b>Computer/Video Signal Compatibility</b> on page 60).</li> </ul>
The image is too large or too small.	<ul style="list-style-type: none"> <li>Image size needs adjusting.</li> </ul>	<ul style="list-style-type: none"> <li>Adjust the image size (refer to <b>Input Position</b> on page 39).</li> </ul>

**Notes:**

## Serial Communications

To interface the PlasmaView VHD with a home theater automation/control system or a PC running terminal emulation software, connect it to the RS-232 output of the VHD Controller as shown in Figure 3-3. Connect your control system or PC to the RS-232 input of the VHD Controller as shown in Figure 3-9.

Configure the RS-232 controller or PC serial port as follows: no parity, eight (8) data bits, one (1) stop bit and no flow control. Set the baud rate to 19200, to match that of the VHD Controller RS-232 port.

Serial commands to the VHD Controller take the following form:

- Commands are not case-sensitive.
- For a single command that takes no parameters, type the command followed by a carriage return; for example, to set the aspect ratio to Letterbox, type `LETTERBOX <Enter>`.
- For a single command that takes a parameter, type the command, a space or a comma and the desired value followed by a carriage return; for example, to set the brightness to -10, type `BRIGHTNESS -10 <Enter>` or `BRIGHTNESS,-10 <Enter>`.
- You can also send a string of multiple commands on a single line, separated by commas. For example, `COMPOSITE,BRIGHTNESS 100,ANAMORPHIC <Enter>` switches to the Composite video input, sets the brightness to 100 and sets the aspect ratio to Anamorphic. Command strings can be up to 255 characters long.



### Note

Avoid combining the `ON` or `POWER 1` commands with other commands on a single line. After sending `ON` or `POWER 1`, allow at least five (5) seconds for the VHD Controller to power up. If you have enabled the ISF splash screen (refer to “Splash Configure” on page 42), allow 15 seconds for the VHD Controller to power up.

Once it does, it will accept and properly execute multiple serial commands.

---

### 6.1 RS-232 Connection and Port Configuration

---

### 6.2 Serial Command Syntax

Table 6-1 lists the RS-232 command set. The “Parameter (min/max)” column shows the valid parameter ranges, or “NA” for commands that take no parameters.

When you enter a valid command, the VHD Controller executes it and acknowledges it with a plus sign on the command line (+ >). When you enter an invalid command – one that is misspelled or followed by values outside the valid range for that command – the VHD Controller ignores it and returns a minus sign (- >).

**Table 6-1. Serial Commands**

Command	Parameter (min/max)	Value Stored?	Description
<b>Power On/Off Commands</b>			
OFF	NA	NA	Turns system off
ON	NA	NA	Turns system on
POWER	0/1	NA	Turns system on or off (toggles on/off state)
POWER?	NA	NA	Returns power status
<b>Input Selection Commands</b>			
COMPONENT	NA	YES	Selects the Component input
COMPOSITE	NA	YES	Selects the Composite video input
DVI1	NA	YES	Selects the DVI 1 input
DVI2	NA	YES	Selects the DVI 2 input
HD1	NA	YES	Selects the RGB HD 1 input
HD2	NA	YES	Selects the RGB HD 2 input
HD1PASS	NA	YES	Loops HD1 input to RGBHV output
HD2PASS	NA	YES	Loops HD2 input to RGBHV output
INPUT?	NA	NA	Returns active input
SVIDEO1	NA	YES	Selects the S-Video 1 input
SVIDEO2	NA	YES	Selects the S-Video 2 input
<b>Aspect Ratio Commands</b>			
ANAMORPHIC	NA	YES	Selects the Anamorphic aspect ratio
ASPECT?	NA	NA	Returns current aspect ratio
ASPECTIN?	NA	NA	Returns the input source aspect ratio
ASPECTOUT?	NA	NA	Returns output screen size
CINEMA	NA	YES	Selects the Cinema aspect ratio
LETTERBOX	NA	YES	Selects the Letterbox aspect ratio
STANDARD	NA	YES	Selects the Standard (4:3) aspect ratio
INTELLIWIDE	NA	YES	Selects the IntelliWide aspect ratio

**Table 6-1. Serial Commands (continued)**

Command	Parameter (min/max)	Value Stored?	Description
<b>Picture Adjust Commands</b>			
BRIGHTNESS	-100/100	YES	Sets a value for brightness
BRIGHTNESS?	NA	NA	Returns brightness setting value
CHROMADELAY	-12/12	YES	Sets a value for input color chroma delay
CHROMADELAY?	NA	NA	Returns input color chroma delay setting
COLOR	-100/100	YES	Sets a value for color
COLOR?	NA	NA	Returns color setting value
CONTRAST	-100/100	YES	Sets a value for contrast
CONTRAST?	NA	NA	Returns contrast setting value
FILMMODE	0/1	YES	Sets Film Mode off (0) or on (1)
FILMMODE?	NA	NA	Returns Film Mode setting (0 = off; 1 = on)
FILTER	0/15	YES	Sets a value for input color noise filter
FILTER?	NA	NA	Returns input color noise filter setting
PHASE	0/3	YES	Adjusts phase
PHASE?	NA	NA	Returns phase setting value
SHARPNESS	-6/6	YES	Sets a value for sharpness
SHARPNESS?	NA	NA	Returns sharpness setting value
TINT	-100/100	YES	Sets a value for tint
TINT?	NA	NA	Returns tint setting value
<b>Image Preset Commands</b>			
CUSTOM1	NA	YES	Loads "Custom 1" image preset
CUSTOM2	NA	YES	Loads "Custom 2" image preset
DAY	NA	YES	Loads "ISF Day" image preset
NIGHT	NA	YES	Loads "ISF Night" image preset
PRESET?	NA	NA	Returns currently-selected preset (ISF Day, ISF Night, Custom 1 or Custom 2)

**Table 6-1. Serial Commands (continued)**

<b>Command</b>	<b>Parameter (min/max)</b>	<b>Value Stored?</b>	<b>Description</b>
<b>Input Position Commands</b>			
IHEIGHT	-100/100	YES	Sets the value for input height
IHEIGHT?	NA	NA	Returns input height value
IHPOS	-100/100	YES	Sets a value for horizontal input position
IHPOS?	NA	NA	Returns input horizontal position value
IVPOS	-100/100	YES	Sets a value for vertical input position
IVPOS?	NA	NA	Returns input vertical position value
IWIDTH	-100/100	YES	Sets the value for input width
IWIDTH?	NA	NA	Returns input horizontal width value
OVERSCAN	0/10	YES	Sets the overscan percentage
OVERSCAN?	NA	NA	Returns overscan percentage
<b>Output Shift Commands</b>			
OHEIGHT	-100/100	YES	Sets the value for output height
OHEIGHT?	NA	NA	Returns output height value
OHPOS	-100/100	YES	Sets the value for output horizontal position
OHPOS?	NA	NA	Returns output horizontal position value
OVPOS	-100/100	YES	Sets the value for output vertical position
OVPOS?	NA	NA	Returns output vertical position value
OWIDTH	-100/100	YES	Sets the value for output width
OWIDTH?	NA	NA	Returns output horizontal width value



**Table 6-1. Serial Commands (continued)**

Command	Parameter (min/max)	Value Stored?	Description
<b>Miscellaneous Commands</b>			
BKGND	-100/100	YES	Sets the background color for 4:3 aspect ratio (-100 = black; 100 = white)
BKGND?	NA	NA	Returns background setting value
DATE?	NA	NA	Returns product manufacture date
DISPLAY	1 or 2	YES	Sets display device input source (1 = RGB; 2 = DVI/HDMI)
DISPLAY?	NA	NA	Returns display device input source value
HDINPUTRES	NA	YES	Sets YpPr input resolution and refresh rate for HD1/HD2, as follows: 0 = 480i 1 = 480p 2 = 576i 3 = 576p 4 = 720p / 60 Hz 5 = 1080i / 60 Hz 6 = 720p / 50 Hz 7 = 1080i / 25 Hz Any other value = Auto
HWVER?	NA	NA	Returns hardware version number
INRES?	NA	NA	Returns input resolution
OUTRES	0/5	YES	Sets output resolution, as follows: 0 = 480i 1 = 576i 2 = 480p 3 = 576p 4 = 720p 5 = 1080i
OUTRES?	NA	NA	Returns output resolution
RGBNN	NA	NA	Sets output color space to RGB with negative horizontal and vertical sync
RGBPP	NA	NA	Sets output color space to RGB with positive horizontal and vertical sync
RGBS	NA	NA	Sets output color space to RGB with composite sync
SWVER?	NA	NA	Returns software version number
TRIGGER	1/3	YES	Assigns trigger to currently-selected aspect ratio

**Table 6-1. Serial Commands (continued)**

Command	Parameter (min/max)	Value Stored?	Description
The following serial commands are meant to emulate buttons on the remote control or VHD Controller front panel. Each button has its own serial command, so effectively it is as if you were using the IR remote only you'll be doing so via serial commands. These commands provide active OSD responses just like the IR remote.			
DOWN	NA	NA	Down-Arrow (▼) key
ENTER	NA	NA	<b>ENTER</b> key
LEFT	NA	NA	Left-Arrow (◀) key
MENU	NA	NA	<b>MENU</b>
RIGHT	NA	NA	Right-Arrow (▶) key
UP	NA	NA	Up-Arrow (▲) key

# Specifications

Table 7-1 lists the PlasmaView VHD specifications.

**Table 7-1. PlasmaView VHD Specifications**

<b>Native Resolution:</b>	1365 x 768
<b>Screen Size (diagonal):</b>	60 in.
<b>Active Screen Area:</b>	51.93 x 29.21 in. (1319.0 x 741.9 mm)
<b>Screen Aspect Ratio:</b>	16:9
<b>Available Aspect Ratios:</b>	Refer to Table 7-2
<b>DTV Compatibility:</b>	480p, 720p, 1080i
<b>Contrast Ratio:</b>	1000:1
<b>ISF Settings:</b>	Yes
<b>Data/Graphics Compatibility:</b>	Refer to Table 7-3
<b>Inputs (from VHD Controller):</b>	(1) DVI 1.0 with HDCP (1) RGB/Component (15-pin D-sub) (1) RS-232 (9-pin, D-sub male)
<b>Outputs:</b>	(1) RGB (15-pin D-sub)
<b>Power Requirements:</b>	100 to 240 VAC, 50/60Hz
<b>Power Consumption:</b>	471 watts (10 watts in standby), maximum
<b>Operating Environment:</b>	40°F to 95°F (5°C to 35°C); 20% to 80% humidity (non-condensing) Altitude = up to 6,000 feet (1,828m)
<b>Dimensions:</b>	See Figure 7-1
<b>Weight (with Stand):</b>	150.5 lbs. (68.27 kg)
<b>Limited Warranty:</b>	Three (3) years parts and labor from the date of delivery to the end user (except for plasma glass panel). Plasma Glass Panel: One (1) year parts and labor from the date of delivery to the end user.
<b>Specifications are subject to change without notice.</b>	

## 7.1 PlasmaView VHD Specifications

## 7.2 VHD Controller Specifications

Table 7-2 lists the VHD Controller specifications.

**Table 7-2. VHD Controller Specifications**

<b>Aspect Ratios:</b>	4:3, Letterbox, 16:9 Anamorphic, IntelliWide, Cinema
<b>Video Standards:</b>	NTSC, PAL
<b>Output Resolution:</b>	480p, 576p, 720p, 840p, 960p, 1080i
<b>Inputs:</b>	(1) Composite; (2) S-Video; (1) Component; (2) HD-R (Pr), G (Y), B (Pb), H, V; (2) DVI with HDCP
<b>Outputs:</b>	(1) HD-R (Pr), G (Y), B (Pb), H, V (1) DVI-I with HDCP
<b>Control Options:</b>	<ul style="list-style-type: none"> <li>- Discrete infrared remote</li> <li>- Serial commands via RS-232</li> <li>- Front-panel controls</li> </ul>
<b>RS-232 Communication Parameters:</b>	19200 bps, no parity, 8 data bits, 1 stop bit, no flow control
<b>Trigger Outputs:</b>	(3) +12 VDC, each rated at 750 mA and thermal fuse-protected
<b>Bandwidth:</b>	150 Mega Samples per Second (MSPS)
<b>Power Requirements:</b>	100 to 240 VAC (auto-sensing), 50/60 Hz, 160 Watts
<b>Operating Environment:</b>	41°F to 95°F (5°C to 35°C), 0% to 90% humidity (non-condensing)
<b>Dimensions:</b>	Width = 17.50 inches (444.5 mm) Depth = 11.19 inches (284.1 mm) Height = 3.75 inches (95.3 mm)
<b>Weight:</b>	13.0 lbs. (5.90 kg)
<b>Regulatory Approvals:</b>	Complies with FCC, CE C-Tick
<b>Limited Warranty:</b>	Two (2) years parts and labor from the date of delivery to the end user.

**Specifications are subject to change without notice.**

Figure 7-1 show the PlasmaView VHD dimensions (all dimensions are in inches).

### 7.3 PlasmaView VHD Dimensions

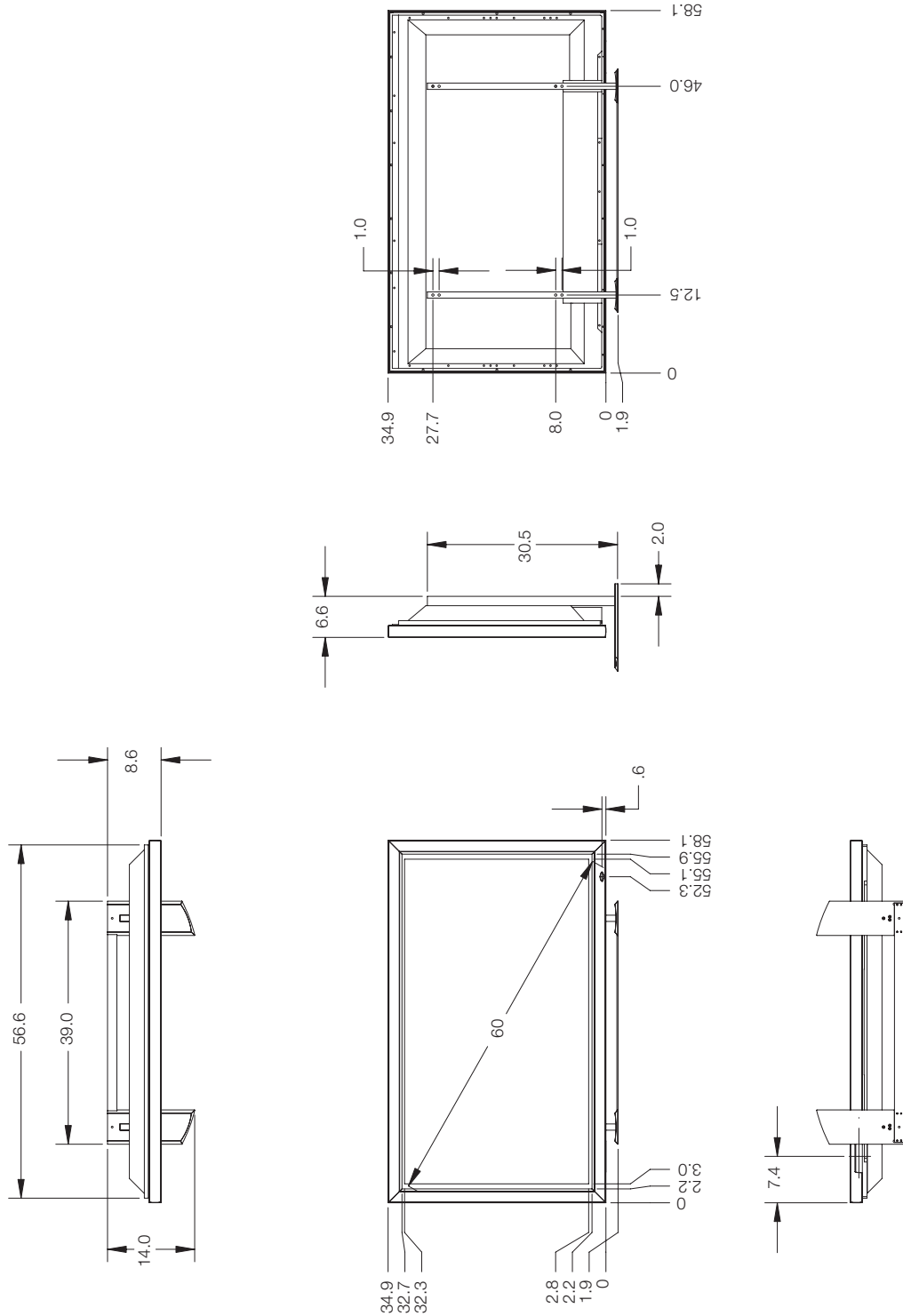

**Figure 7-1. PlasmaView VHD Dimensions (with Optional Table Stand)**

## 7.4 Computer/Video Signal Compatibility

The PlasmaView VHD can display video signals from a variety of computer sources via its RGB and DVI inputs.

Table 7-3 lists the signal types that are compatible with the PlasmaView VHD.

**Table 7-3. Computer/Video Signal Compatibility Chart**

Input Resolution (DotsxLines)	Refresh Rate		INPUT 1	INPUT 2	Remarks
	Vert. (Hz)	Horiz. (kHz)			
640x400	70.1	31.5	√	–	
720x400	70.1	31.5	√	√	
	85.1	37.9	√	√	
640x480	60.0	31.5	√	√	
	66.7	35.0	√	–	Apple® Macintosh® 13"
	72.8	37.9	√	√	
	75.0	37.5	√	√	
	85.0	43.3	√	√	
	100.4	51.1	√	√	I/O DATA
120.4	61.3	√	√	I/O DATA	
848x480	60.0	31.0	√	√	
852x480	60.0	31.7	√	√	I/O DATA
800x600	56.0	35.2	√	√	
	60.0	37.9	√	√	
	72.0	48.1	√	√	
	75.0	46.9	√	√	
	85.0	53.7	√	√	
	99.8	63.0	√	√	I/O DATA
120.0	75.7	√	√	I/O DATA	
832x624	74.6	49.7	√	–	Apple Macintosh 16"
1024x768	60.0	48.4	√	√	
	60.0	49.7	√	√	
	70.0	56.5	√	√	
	75.0	60.0	√	√	
	74.9	60.2	√	–	Apple Macintosh 19"
	85.0	68.7	√	√	
	100.6	80.5	√	√	I/O DATA
119.4	95.6	√	√		
1152x864	60.0	53.7	√	√	
	72.0	64.9	√	√	
	75.0	67.5	√	√	

**Table 7-3. Computer/Video Signal Compatibility Chart (continued)**

Input Resolution (DotsxLines)	Refresh Rate		INPUT 1	INPUT 2	Remarks
	Vert. (Hz)	Horiz. (kHz)			
1152x870	75.1	68.5	√	–	Apple Macintosh 21"
1152x900	66.0	61.8	√	√	Sun Microsystems LO
	76.0	71.7	√	√	Sun Microsystems HI
1280x768	56.0	45.1	√	√	
	60.0	47.8	√	√	
	70.0	56.1	√	√	
1280x800	60.0	49.7	√	√	CVT
1280x854	60.0	53.1	√	√	PC
1280x960	60.0	60.0	√	√	
	85.0	85.9	√	√	
1280x1024	60.0	64.0	√	√	Workstation (SGI)
	60.0	64.6	√	√	Workstation (EWS4800)
	71.2	75.1	√	√	Workstation (EWS4800)
	72.0	78.1	√	√	Workstation (HP)
	75.0	80.0	√	√	
	76.1	81.1	√	√	Workstation (SUN)
	85.0	91.2	√	√	
	100.1	108.5	√	–	I/O DATA
1360x765	60.0	47.7	√	–	
1360x768	60.0	47.7	√	√	I/O DATA
1376x768	59.9	48.3	√	√	I/O DATA
1400x1050	60.0	65.3	√	√	
	74.9	82.3	–	√	
	75.0	82.3	√	–	
	85.0	93.9	√	–	
1440x900	60.0	56.0	√	√	Apple Macintosh 17"
1600x1200	60.0	75.0	√	√	
	65.0	81.3	√	–	
	70.0	87.5	√	–	
	75.0	93.8	√	–	
	85.0	106.3	√	–	
1680x1050	60.0	65.3	√	√	
1920x1200	60.0	74.6	√	–	CVT
1920x1200RB	60.0	74.0	√	√	CVT

**Notes:**



# PlasmaView VHD Service Remote Control

The PlasmaView VHD system includes two remote control units: the standard VHD Controller remote control (see Figure 2-5) and the Service Remote Control, shown in Figure A-1 and described in the paragraphs that follow.

## A.1 Overview

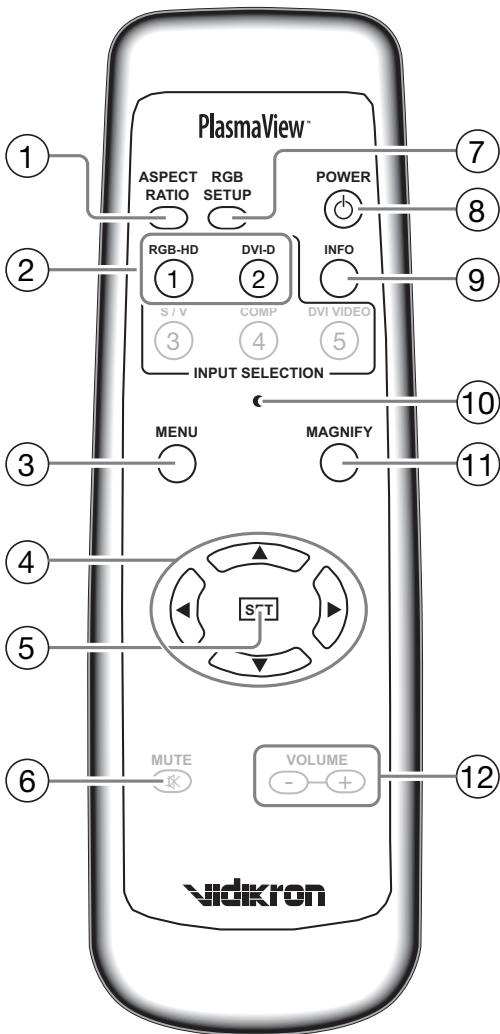

Figure A-1. PlasmaView VHD Service Remote Control



**Note**

**The PlasmaView VHD service remote control is intended for use only by authorized Vidikron dealers. Use it only as described here or as instructed to by Vidikron Technical Support.**

1. **ASPECT RATIO**  
Press this button repeatedly to select a display aspect ratio (this may be necessary with certain computer resolutions).
2. **Input Selection Buttons:**
  - RGB-HD**  
Selects INPUT 1 (ANALOG RGB IN) on the PlasmaView VHD.
  - DVI-D**  
Selects INPUT 2 (DIGITAL RGB) on the PlasmaView VHD.
3. **MENU**  
Pressing the **MENU** button brings up the main menu. Also, if you are in an adjustment mode or function, pressing **MENU** brings the menu back one level.
4. **Directional Buttons ( ▲ / ▼ / ◀ / ▶ )**  
Use these buttons to navigate the OSD menus and adjust various settings.
5. **SET BUTTON**  
When an item is highlighted on the On-Screen Display, the **SET** button selects the item.
6. **MUTE**  
Not used with the PlasmaView VHD.
7. **RGB SETUP**  
When using INPUT 1 to display images from a computer, press this button to automatically set the Position, Clock and Phase settings to their optimum values.
8. **STANDBY/ON ( ⏻ )**  
Press to put the display into operation or standby mode.
9. **INFO**  
Displays currently-selected input, aspect ratio and signal timing information.
10. **INSTALLER ADJUST (pin hole)**  
Used to access the INSTALLER ADJUST menu.
11. **MAGNIFY**  
Press this button to select and enlarge one part of the screen image.
12. **VOLUME + / -**  
Not used with the PlasmaView VHD.

For the vast majority of installations, the VHD Controller remote control gives you all the control you need over display quality settings. However, there are two settings internal to the PlasmaView VHD that can improve the displayed image quality on INPUT 1: VID NR (noise reduction) and MPEG FILTER. These settings can be found in the Setup Menu, shown in Figure A-2.

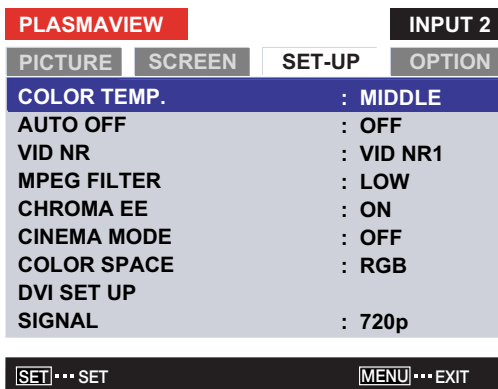

**Figure A-2. PlasmaView VHD Setup Menu**

To apply Digital Noise Reduction (DNR) to the input signal, select Video NR from the Set-Up menu. Noise reduction is useful for improving the signal-to-noise ratio of video signals.

◀ **Video NR (Noise Reduction)**

To change the Noise Reduction setting on INPUT 1:

1. Press **1** to switch to PlasmaView VHD INPUT 1.
2. Press **MENU** on the PlasmaView VHD Service Remote Control.
3. Press ◀ or ▶ to select SETUP.
4. Press ▼ to select VIDEO NR, then press **SET**.
5. Press ◀ or ▶ to select the desired amount of noise reduction (OFF, LOW, MIDDLE or HIGH).
6. Press **SET** to confirm your selection.

**MPEG Filter** ➤ Use the MPEG Filter to reduce or eliminate so-called “mosquito noise” in MPEG-compressed video signals (digital broadcasts or DVDs). Set it to LOW, MIDDLE or HIGH, as needed to minimize distortion around the edges of moving objects, moving artifacts around edges and/or blotchy noise patterns superimposed over the objects.

To change the MPEG Filter setting on INPUT 1:

1. Press **1** to switch to PlasmaView VHD INPUT 1.
2. Press **MENU** on the PlasmaView VHD Service Remote Control.
3. Press ◀ or ▶ to select SETUP.
4. Press ▼ to select MPEG FILTER, then press **SET**.
5. Press ◀ or ▶ to select the desired amount of filtering (OFF, LOW, MIDDLE or HIGH).
6. Press **SET** to confirm your selection.



RUMA-009820  
rev. 12-22-06 v1.1



Vidikron  
2900 Faber Street  
Union City, CA 94587  
510-324-5900  
Fax 510-324-5905  
1-888-4-VIDIKRON  
[www.vidikron.com](http://www.vidikron.com)



SERIAL NUMBER

