



# M48T212A

## 3.3V TIMEKEEPER<sup>®</sup> CONTROLLER

PRELIMINARY DATA

- CONVERTS LOW POWER SRAM into NVRAMs
- YEAR 2000 COMPLIANT (4-Digit Year)
- USES SUPER CAPACITOR or LITHIUM BATTERY (User Supplied)
- BATTERY LOW FLAG
- INTEGRATED REAL TIME CLOCK, POWER-FAIL CONTROL CIRCUIT
- AUTOMATIC POWER-FAIL CHIP DESELECT and WRITE PROTECTION
- WATCHDOG TIMER
- WRITE PROTECT VOLTAGES  
( $V_{PFD}$  = Power-fail Deselect Voltage):
  - M48T212A:  $2.7V \leq V_{PFD} \leq 3.0V$
- MICROPROCESSOR POWER-ON RESET
- PROGRAMMABLE ALARM OUTPUT ACTIVE in the BATTERY BACKED-UP MODE

### DESCRIPTION

The M48T212A is a self-contained device that includes a real time clock (RTC), programmable alarms, a watchdog timer, and two external chip enable outputs which provide control of up to four (two in parallel) external low-power static RAMs.

A built-in 32.768 kHz oscillator (external crystal controlled) is used for the clock/calendar function. Access to all TIMEKEEPER functions and the external RAM is the same as conventional byte-wide SRAM. The 16 TIMEKEEPER Registers offer Century, Year, Month, Date, Day, Hour, Minute, Second, Control, Calibration, Alarm, Watchdog, and Flags. Externally attached static RAMs are controlled by the M48T212A via the  $\overline{E1CON}$  and  $\overline{E2CON}$  signals (see Table 4).

Automatic backup and write protection for an external SRAM is provided through  $V_{OUT}$ ,  $\overline{E1CON}$  and  $\overline{E2CON}$  pins. (Users are urged to insure that voltage specifications, for both the controller chip and external SRAM chosen, are similar).

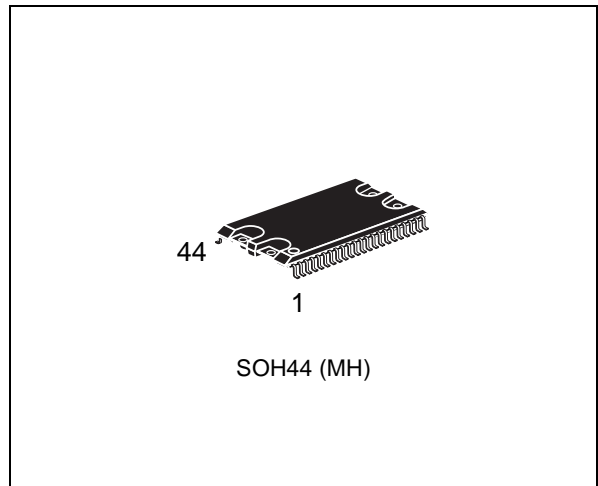

Figure 1. Logic Diagram

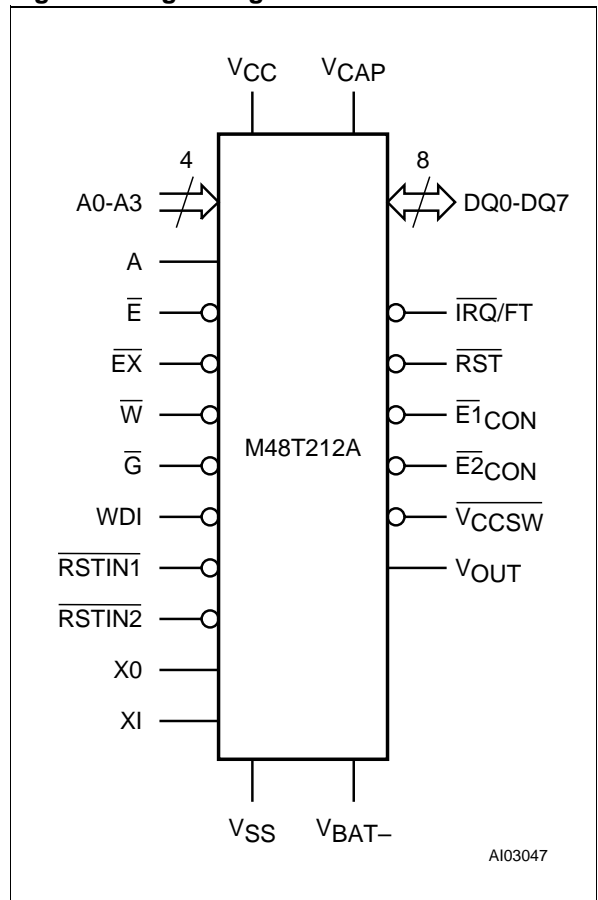

Figure 2. SOIC Connections

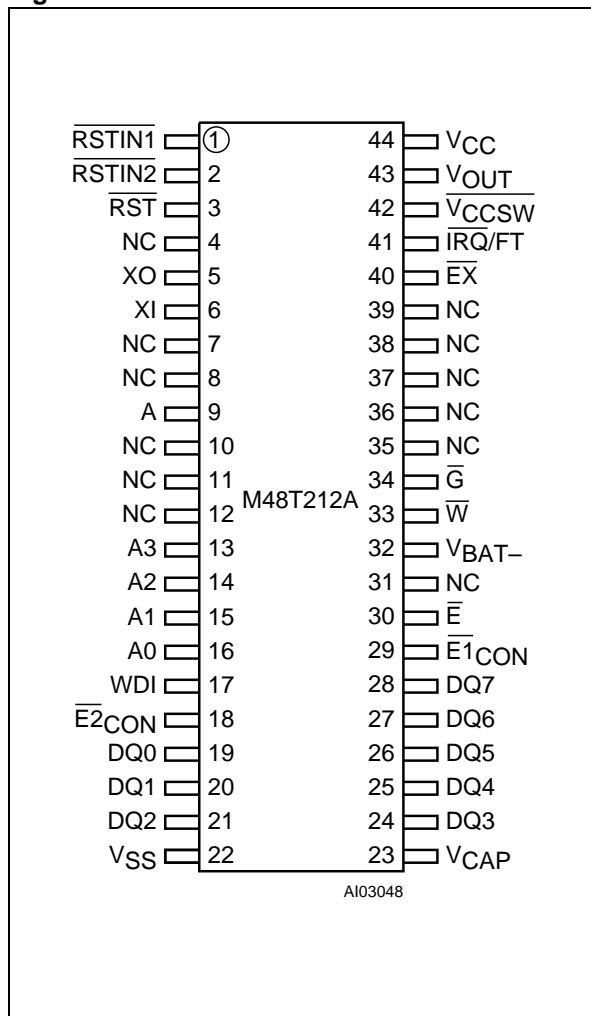

Table 1. Signal Names

A0-A3	Address Inputs
DQ0-DQ7	Data Inputs/Outputs
XO	Oscillator Output
XI	Oscillator Input
RSTIN1	Reset 1 Input
RSTIN2	Reset 2 Input
RST	Reset Output (Open Drain)
WDI	Watchdog Input
A	Bank Select Input
E	Chip Enable Input
EX	External Chip Enable Input
G	Output Enable Input
W	Write Enable Input
E1CON	RAM Chip Enable 1 Output
E2CON	RAM Chip Enable 2 Output
IRQ/FT	Int/Freq Test Output (Open Drain)
VCCSW	VCC Switch Output
VOUT	Supply Voltage Output
VCAP	Super Capacitor Input
VBAT-	Battery Ground Pin (optional)
VCC	Supply Voltage
VSS	Ground
NC	Not Connected internally

The lithium energy source (or super capacitor) used to permanently power the real time clock is also used to retain RAM data in the absence of VCC power through the VOUT pin.

The chip enable outputs to RAM (E1CON and E2CON) are controlled during power transients to prevent data corruption. The date is automatically adjusted for months with less than 31 days and corrects for leap years. The internal watchdog timer provides programmable alarm windows.

The nine clock bytes (Fh - 9h and 1h) are not the actual clock counters, they are memory locations consisting of BiPORT™ read/write memory cells within the static RAM array. Clock circuitry updates the clock bytes with current information once per second. The information can be accessed by the user in the same manner as any other location in the static memory array.

Byte 8h is the clock control register. This byte controls user access to the clock information and also stores the clock calibration setting. Byte 7h con-

tains the watchdog timer setting. The watchdog timer can generate either a reset or an interrupt, depending on the state of the Watchdog Steering bit (WDS). Bytes 6h-2h include bits that, when programmed, provide for clock alarm functionality.

Alarms are activated when the register content matches the month, date, hours, minutes, and seconds of the clock registers. Byte 1h contains century information. Byte 0h contains additional flag information pertaining to the watchdog timer, alarm and battery status.

The M48T212A also has its own Power-Fail Detect circuit. This control circuitry constantly monitors the supply voltage for an out of tolerance condition. When VCC is out of tolerance, the circuit write protects the TIMEKEEPER register data and external SRAM, providing data security in the midst of unpredictable system operation. As VCC falls, the control circuitry automatically switches to the battery, maintaining data and clock operation until valid power is restored.



**Table 2. Absolute Maximum Ratings (1)**

Symbol	Parameter	Value	Unit
T <sub>A</sub>	Ambient Operating Temperature	0 to 70	°C
T <sub>STG</sub>	Storage Temperature (V <sub>CC</sub> Off, Oscillator Off)	-55 to 125	°C
T <sub>SLD</sub> (2)	Lead Solder Temperature for 10 sec	260	°C
V <sub>IO</sub>	Input or Output Voltages	-0.3 to 4.6	V
V <sub>CC</sub>	Supply Voltage	-0.3 to 4.6	V
I <sub>O</sub>	Output Current	20	mA
P <sub>D</sub>	Power Dissipation	1	W

Note: 1. Stresses greater than those listed under "Absolute Maximum Ratings" may cause permanent damage to the device. This is a stress rating only and functional operation of the device at these or any other conditions above those indicated in the operational section of this specification is not implied. Exposure to the absolute maximum rating conditions for extended periods of time may affect reliability.

2. Soldering temperature not to exceed 260°C for 10 seconds (total thermal budget not to exceed 150°C for longer than 30 seconds).

**CAUTION:** Negative undershoots below -0.3V are not allowed on any pin while in the Battery Back-up mode.

**Table 3. Operating Modes (1)**

Mode	V <sub>CC</sub>	$\bar{E}$	$\bar{G}$	$\bar{W}$	DQ7-DQ0	Power
Deselect	3.0V to 3.6V	V <sub>IH</sub>	X	X	High-Z	Standby
Write		V <sub>IL</sub>	X	V <sub>IL</sub>	D <sub>IN</sub>	Active
Read		V <sub>IL</sub>	V <sub>IL</sub>	V <sub>IH</sub>	D <sub>OUT</sub>	Active
Read		V <sub>IL</sub>	V <sub>IH</sub>	V <sub>IH</sub>	High-Z	Active
Deselect	V <sub>SO</sub> to V <sub>PFD</sub> (min) (2)	X	X	X	High-Z	CMOS Standby
Deselect	≤ V <sub>SO</sub> (2)	X	X	X	High-Z	Battery Back-Up

Note: 1. X = V<sub>IH</sub> or V<sub>IL</sub>.

2. V<sub>SO</sub> = Battery Back-up Switchover Voltage. (See Table 7 for details).

**Table 4. Truth Table for SRAM Bank Select (1)**

Mode	V <sub>CC</sub>	$\bar{E}X$	A	$\bar{E}1CON$	$\bar{E}2CON$	Power
Select	3.0V to 3.6V	Low	Low	Low	High	Active
		Low	High	High	Low	Active
Deselect		High	X	High	High	Standby
Deselect	V <sub>SO</sub> to V <sub>PFD</sub> (min) (2)	X	X	High	High	CMOS Standby
Deselect	≤ V <sub>SO</sub> (2)	X	X	High	High	Battery Back-Up

Note: 1. X = V<sub>IH</sub> or V<sub>IL</sub>.

2. V<sub>SO</sub> = Battery Back-up Switchover Voltage. (See Table 7 for details).

Figure 3. Hardware Hookup

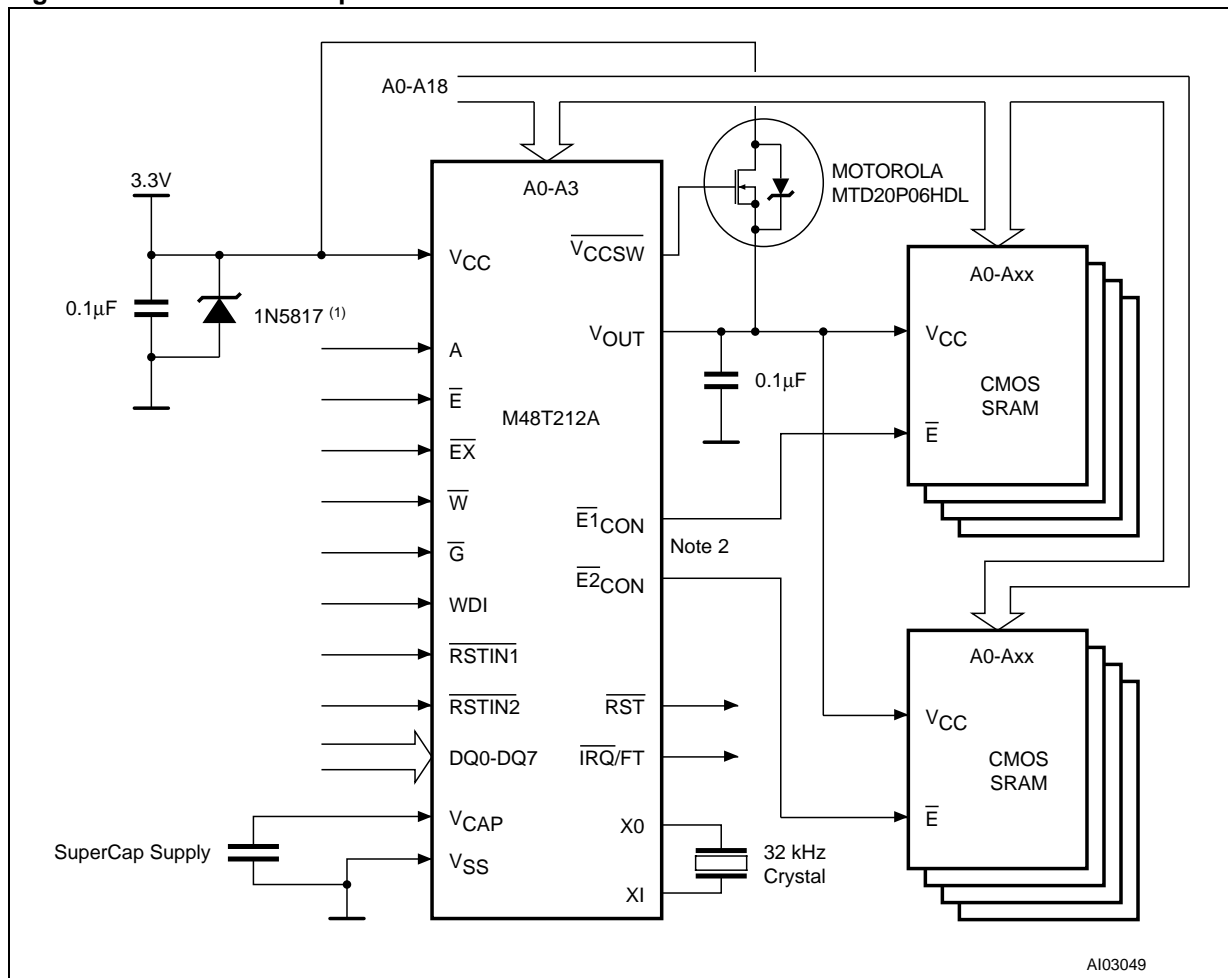

Note: 1. See description in Power Supply Decoupling and Undershoot Protection.  
 2. Traces connecting  $\overline{E1CON}$  and  $\overline{E2CON}$  to external SRAM should be as short as possible.

Figure 4. AC Testing Load Circuit (3,4)

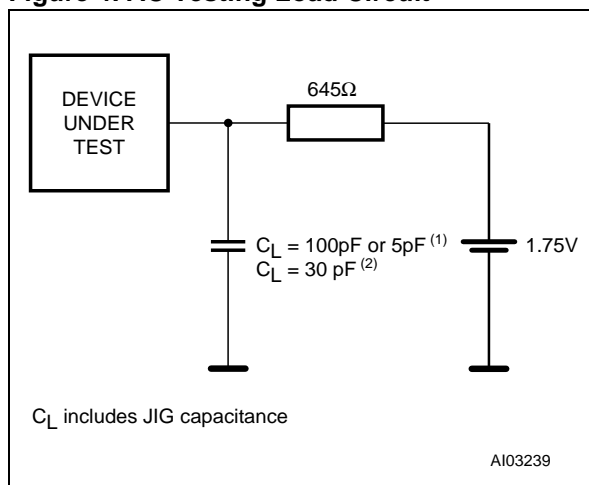

Note: 1. DQ0-DQ7  
 2.  $\overline{E1CON}$  and  $\overline{E2CON}$   
 3. Excluding open-drain output pins

Table 5. AC Measurement Conditions

Input Rise and Fall Times	≤ 5ns
Input Pulse Voltages	0 to 3V
Input and Output Timing Ref. Voltages	1.5V

Note that Output Hi-Z is defined as the point where data is no longer driven.

**Table 6. Capacitance (1)**(T<sub>A</sub> = 25 °C, f = 1 MHz)

Symbol	Parameter	Test Condition	Min	Max	Unit
C <sub>IN</sub>	Input Capacitance	V <sub>IN</sub> = 0V		10	pF
C <sub>OUT</sub> (2)	Input/Output Capacitance	V <sub>OUT</sub> = 0V		10	pF

Note: 1. Sampled only, not 100% tested.

2. Outputs deselected.

**Table 7. DC Characteristics**(T<sub>A</sub> = 0 to 70°C; V<sub>CC</sub> = 3V to 3.6V)

Symbol	Parameter	Test Condition	Min	Typ	Max	Unit
I <sub>LI</sub> (1,2)	Input Leakage Current	0V ≤ V <sub>IN</sub> ≤ V <sub>CC</sub>			±1	μA
I <sub>LO</sub> (1)	Output Leakage Current	0V ≤ V <sub>OUT</sub> ≤ V <sub>CC</sub>			±1	μA
I <sub>CC</sub>	Supply Current	Outputs Open		4	10	mA
I <sub>CC1</sub>	Supply Current (Standby) TTL	$\bar{E} = V_{IH}$			3	mA
I <sub>CC2</sub>	Supply Current (Standby) CMOS	$\bar{E} = V_{CC} - 0.2$			2	mA
I <sub>BAT</sub>	Battery Current OSC ON			575	800	nA
	Battery Current OSC OFF				100	nA
V <sub>IL</sub>	Input Low Voltage		-0.3		0.8	V
V <sub>IH</sub>	Input High Voltage		2.0		V <sub>CC</sub> + 0.3	V
V <sub>OL</sub>	Output Low Voltage	I <sub>OL</sub> = 2.1mA			0.4	V
	Output Low Voltage (open drain) (3)	I <sub>OL</sub> = 10mA			0.4	V
V <sub>OH</sub>	Output High Voltage	I <sub>OH</sub> = -1.0mA	2.4			V
V <sub>OHB</sub> (4)	V <sub>OH</sub> Battery Back-up	I <sub>OUT2</sub> = -1.0μA	2.0		3.6	V
I <sub>OUT1</sub> (5)	V <sub>OUT</sub> Current (Active)	V <sub>OUT1</sub> > V <sub>CC</sub> - 0.3			70	mA
I <sub>OUT2</sub>	V <sub>OUT</sub> Current (Battery Back-up)	V <sub>OUT2</sub> > V <sub>BAT</sub> - 0.3			100	μA
V <sub>PFD</sub>	Power-fail Deselect Voltage		2.7	2.9	3.0	V
V <sub>SO</sub>	Battery Back-up Switchover Voltage			V <sub>PFD</sub> - 100mV		V
V <sub>BAT</sub>	Battery Voltage			3.0		V
V <sub>CAP</sub>	Capacitor Voltage (6)			V <sub>CC</sub>		V

Note: 1. Outputs deselected.

2. RSTIN1 and RSTIN2 internally pulled-up to V<sub>CC</sub> through 100KΩ resistor. WDI internally pulled-down to V<sub>SS</sub> through 100KΩ resistor.3. For  $\overline{IRQ/FT}$  &  $\overline{RST}$  pins (Open Drain).4. Conditioned outputs ( $\bar{E}1_{CON}$  -  $\bar{E}2_{CON}$ ) can only sustain CMOS leakage currents in the battery back-up mode. Higher leakage currents will reduce battery life.5. External SRAM must match TIMEKEEPER Controller chip V<sub>CC</sub> specification.

6. When fully charged.

Figure 5. Power Down/Up AC Waveform

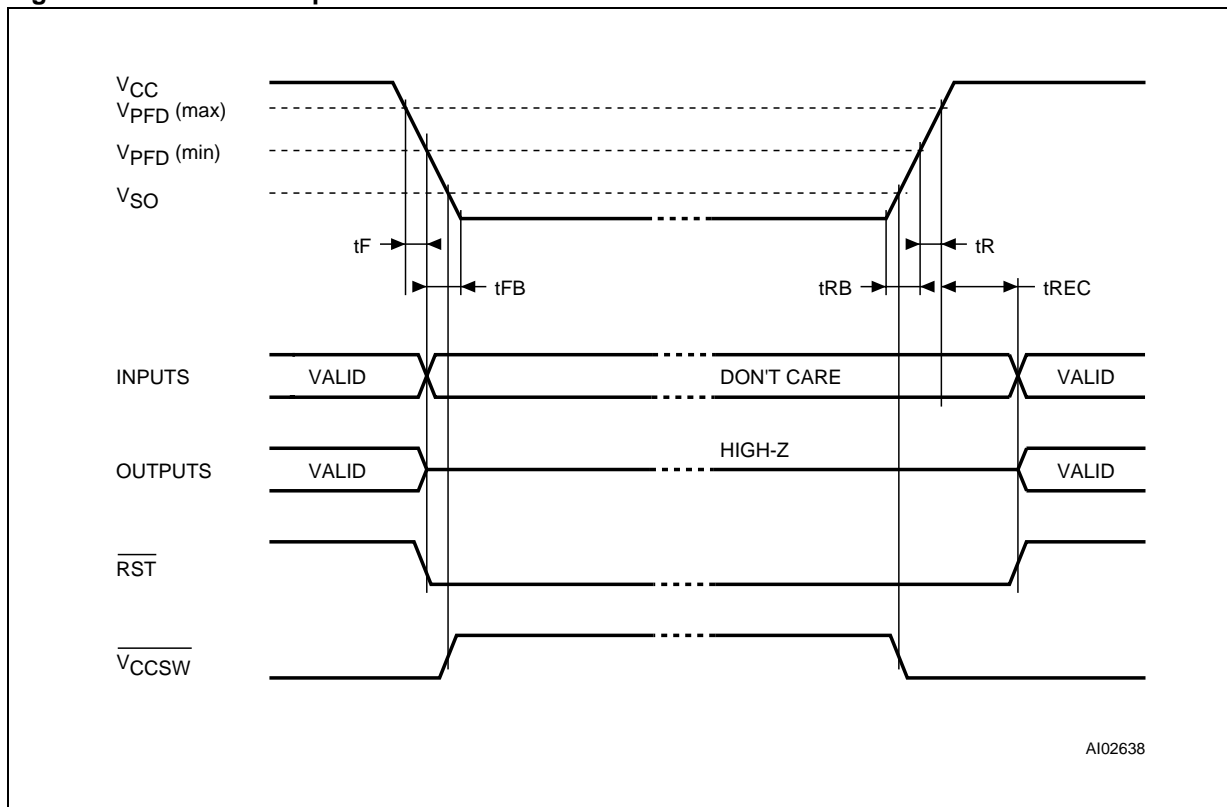

AI02638

Table 8. Power Down/Up AC Characteristics  
(T<sub>A</sub> = 0 to 70°C)

Symbol	Parameter	Min	Max	Unit
t <sub>F</sub>	V <sub>PF<sub>FD</sub></sub> (max) to V <sub>PF<sub>FD</sub></sub> (min) V <sub>CC</sub> Fall Time	300		μs
t <sub>FB</sub>	V <sub>PF<sub>FD</sub></sub> (min) to V <sub>SS</sub> V <sub>CC</sub> Fall Time	150		μs
t <sub>R</sub>	V <sub>PF<sub>FD</sub></sub> (min) to V <sub>PF<sub>FD</sub></sub> (max) V <sub>CC</sub> Rise Time	10		μs
t <sub>REC</sub>	V <sub>PF<sub>FD</sub></sub> (max) to RST High	40	200	ms
t <sub>RB</sub>	V <sub>SS</sub> to V <sub>PF<sub>FD</sub></sub> (min) V <sub>CC</sub> Rise Time	5		μs

**Table 9. Chip Enable Control and Bank Select Characteristics**  
( $T_A = 0$  to  $70^\circ\text{C}$ )

Symbol	Parameter	M48T212A		Unit
		-85		
		Min	Max	
$t_{\text{EXPD}}$	$\overline{\text{EX}}$ to $\overline{\text{E1CON}}$ or $\overline{\text{E2CON}}$ (Low or High)		15	ns
$t_{\text{APD}}$	A to $\overline{\text{E1CON}}$ or $\overline{\text{E2CON}}$ (Low or High)		15	ns

**Figure 6. Chip Enable Control and Bank Select Timing**

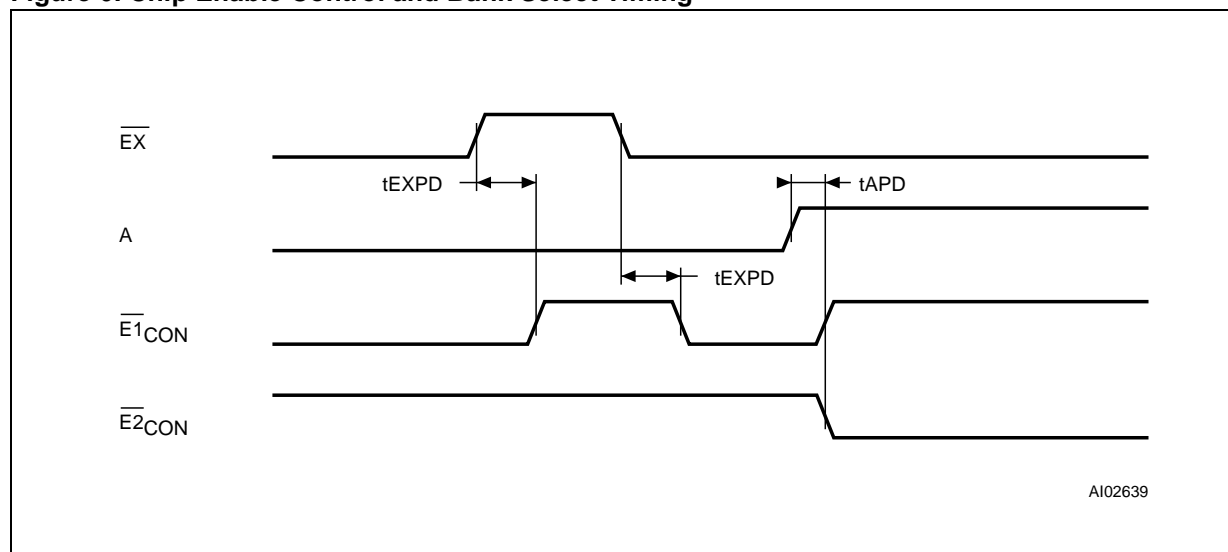

**Table 10. Read Mode Characteristics**  
( $T_A = 0$  to  $70^\circ\text{C}$ )

Symbol	Parameter	M48T212A		Unit
		-85		
		Min	Max	
$t_{\text{AVAV}}$	Read Cycle Time	85		ns
$t_{\text{AVQV}}$	Address Valid to Output Valid		85	ns
$t_{\text{ELQV}}$	Chip Enable Low to Output Valid		85	ns
$t_{\text{GLQV}}$	Output Enable Low to Output Valid		35	ns
$t_{\text{ELQX}}^{(1)}$	Chip Enable Low to Output Transition	5		ns
$t_{\text{GLQX}}^{(1)}$	Output Enable Low to Output Transition	0		ns
$t_{\text{EHQZ}}^{(1)}$	Chip Enable High to Output Hi-Z		25	ns
$t_{\text{GHQZ}}^{(1)}$	Output Enable High to Output Hi-Z		25	ns
$t_{\text{AXQX}}$	Address Transition to Output Transition	5		ns

Note: 1.  $C_L = 5\text{pF}$

## M48T212A

### Address Decoding

The M48T212A accommodates 4 address lines (A3-A0) which allow access to the sixteen bytes of the TIMEKEEPER clock registers. All TIMEKEEPER registers reside in the controller chip itself. All TIMEKEEPER registers are accessed by enabling  $\bar{E}$  (Chip Enable).

### READ MODE

The M48T212A executes a read cycle whenever  $\bar{W}$  (Write Enable) is high and  $\bar{E}$  (Chip Enable) is low. The unique address specified by the address inputs (A3-A0) defines which one of the on-chip TIMEKEEPER registers is to be accessed. When

the address presented to the M48T212A is in the range of 0h-Fh, one of the on-board TIMEKEEPER registers is accessed and valid data will be available to the eight data output drivers within  $t_{AVQV}$  after the address input signal is stable, providing that the  $\bar{E}$  and  $\bar{G}$  access times are also satisfied. If they are not, then data access must be measured from the latter occurring signal ( $\bar{E}$  or  $\bar{G}$ ) and the limiting parameter is either  $t_{ELQV}$  for  $\bar{E}$  or  $t_{GLQV}$  for  $\bar{G}$  rather than the address access time. When  $\bar{EX}$  input is low, an external SRAM location will be selected.

**Note:** Care should be taken to avoid taking both  $\bar{E}$  and  $\bar{EX}$  low simultaneously to avoid bus contention.

**Table 11. Write Mode AC Characteristics**

( $T_A = 0$  to  $70^\circ\text{C}$ )

Symbol	Parameter	M48T212A		Unit
		-85		
		Min	Max	
$t_{AVAV}$	Write Cycle Time	85		ns
$t_{AVWL}$	Address Valid to Write Enable Low	0		ns
$t_{AVEL}$	Address Valid to Chip Enable Low	0		ns
$t_{WLWH}$	Write Enable Pulse Width	55		ns
$t_{ELEH}$	Chip Enable Low to Chip Enable High	60		ns
$t_{WHAX}$	Write Enable High to Address Transition	0		ns
$t_{EHAX}$	Chip Enable High to Address Transition	0		ns
$t_{DVWH}$	Input Valid to Write Enable High	30		ns
$t_{DVEH}$	Input Valid to Chip Enable High	30		ns
$t_{WHDX}$	Write Enable High to Input Transition	0		ns
$t_{EHDX}$	Chip Enable High to Input Transition	0		ns
$t_{WLQZ}^{(1,2)}$	Write Enable Low to Output High-Z		25	ns
$t_{AVWH}$	Address Valid to Write Enable High	65		ns
$t_{AVEH}$	Address Valid to Chip Enable High	65		ns
$t_{WHQX}^{(1,2)}$	Write Enable High to Output Transition	5		ns

Note: 1.  $C_L = 5\text{pF}$ .

2. If  $\bar{E}$  goes low simultaneously with  $\bar{W}$  going low, the outputs remain in the high impedance state.



Figure 7. Read Cycle Timing: RTC Control Signals

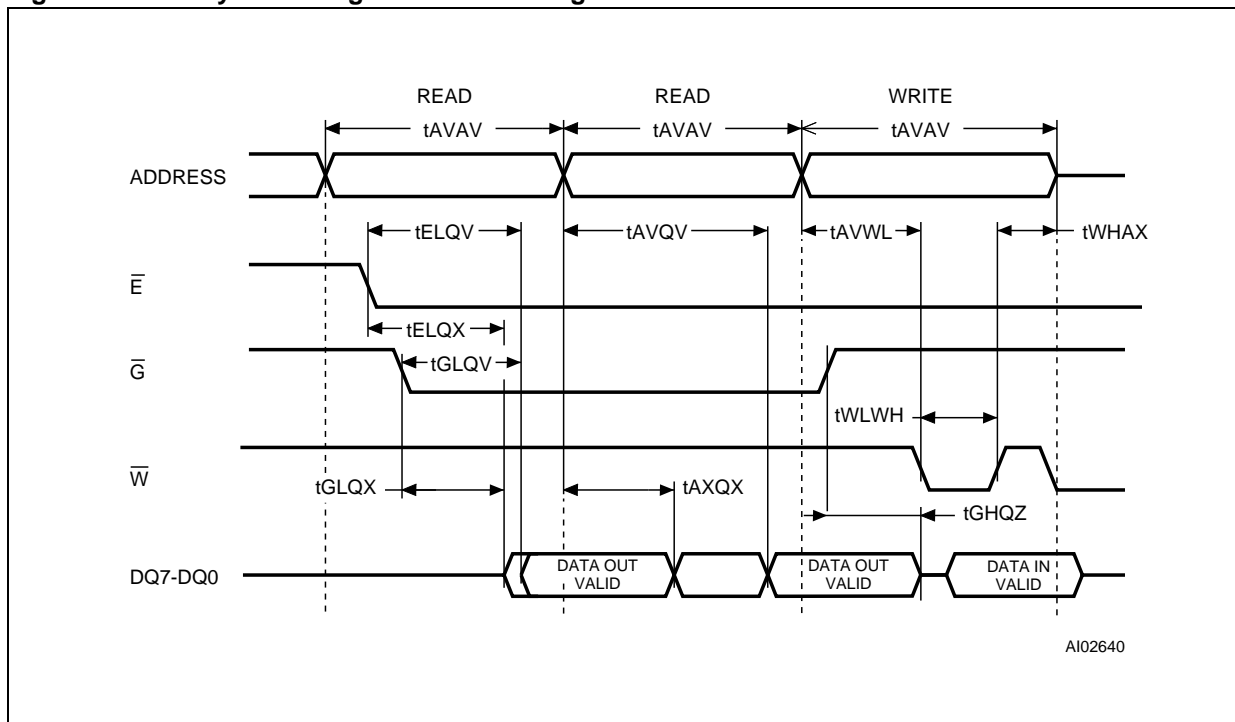

Figure 8. Write Cycle Timing: RTC Control Signals

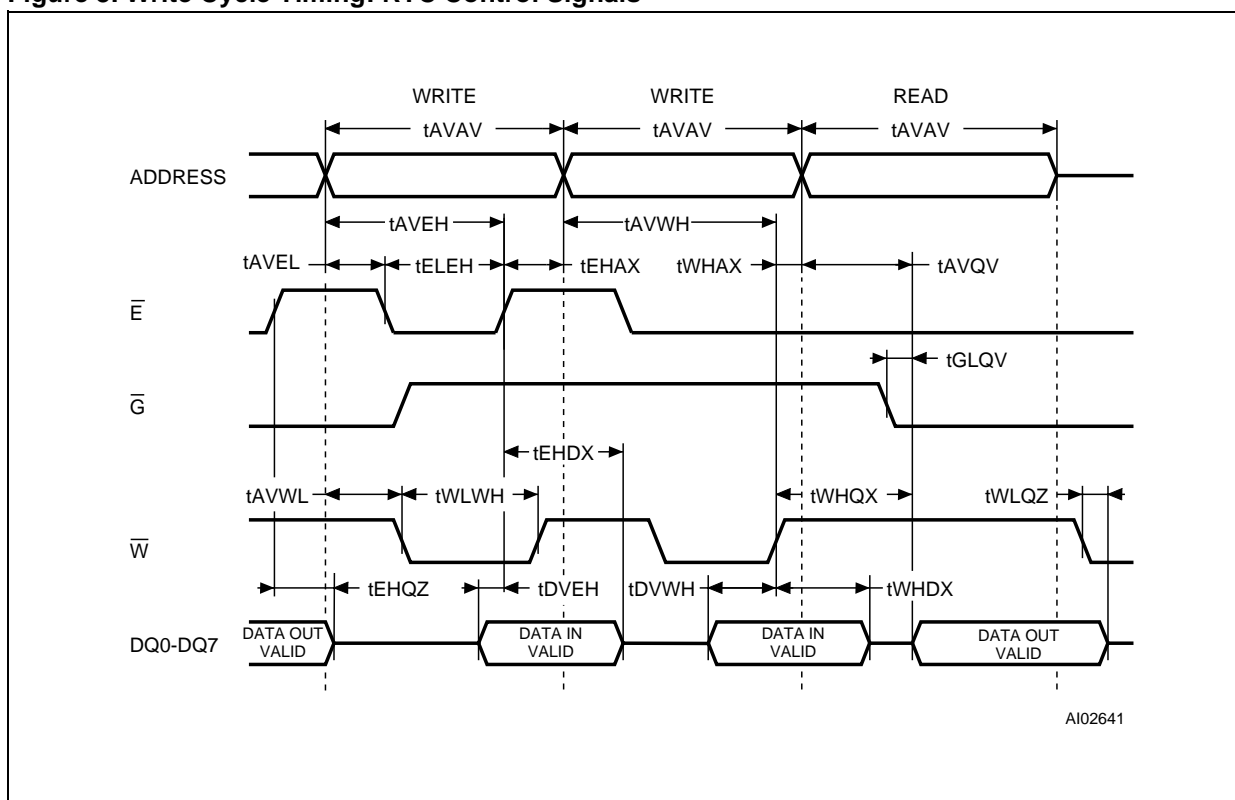
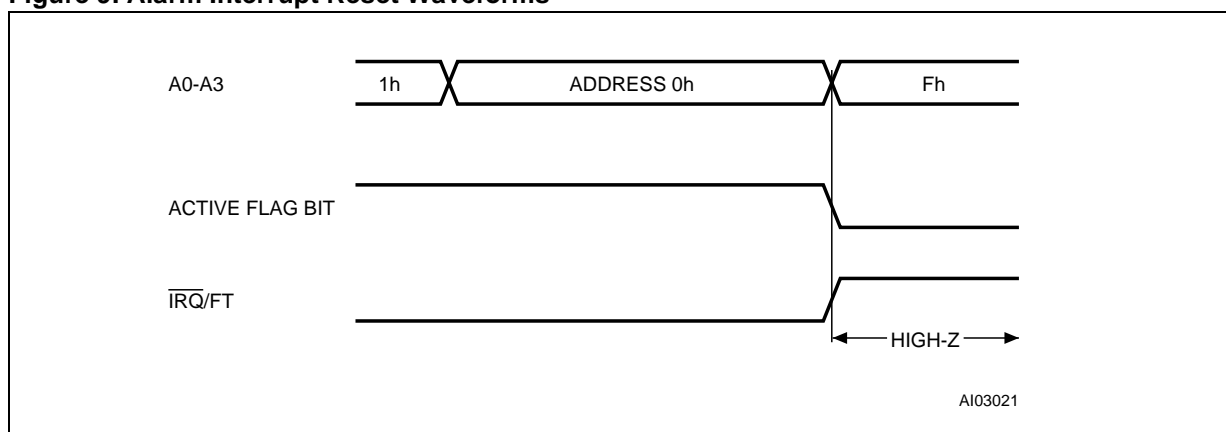

Table 12. Alarm Repeat Modes

RPT5	RPT4	RPT3	RPT2	RPT1	Alarm Setting
1	1	1	1	1	Once per Second
1	1	1	1	0	Once per Minute
1	1	1	0	0	Once per Hour
1	1	0	0	0	Once per Day
1	0	0	0	0	Once per Month
0	0	0	0	0	Once per Year

Figure 9. Alarm Interrupt Reset Waveforms



**WRITE MODE**

The M48T212A is in the Write Mode whenever  $\overline{W}$  (Write Enable) and  $\overline{E}$  (Chip Enable) are in a low state after the address inputs are stable. The start of a write is referenced from the latter occurring falling edge of  $\overline{W}$  or  $\overline{E}$ . A write is terminated by the earlier rising edge of  $\overline{W}$  or  $\overline{E}$ . The addresses must be held valid throughout the cycle.  $\overline{E}$  or  $\overline{W}$  must return high for a minimum of  $t_{EHAX}$  from Chip Enable or  $t_{WHAX}$  from Write Enable prior to the initiation of another read or write cycle. Data-in must be valid  $t_{DVWH}$  prior to the end of write and remain valid for  $t_{WHDX}$  afterward.

$\overline{G}$  should be kept high during write cycles to avoid bus contention; although, if the output bus has been activated by a low on  $\overline{E}$  and  $\overline{G}$  a low on  $\overline{W}$  will disable the outputs  $t_{WLQZ}$  after  $\overline{W}$  falls.

When  $\overline{E}$  is low during the write, one of the on-board TIMEKEEPER registers will be selected and data will be written into the device. When  $\overline{EX}$  is low (and  $\overline{E}$  is high) an external SRAM location is selected.

**Note:** Care should be taken to avoid taking both  $\overline{E}$  and  $\overline{EX}$  low simultaneously to avoid bus contention.

**DATA RETENTION MODE**

With valid  $V_{CC}$  applied, the M48T212A can be accessed as described above with read or write cycles. Should the supply voltage decay, the M48T212A will automatically deselect, write protecting itself (and any external SRAM) when  $V_{CC}$  falls between  $V_{PFD}(\max)$  and  $V_{PFD}(\min)$ . This is accomplished by internally inhibiting access to the clock registers via the  $\overline{E}$  signal. At this time, the Reset pin (RST) is driven active and will remain active until  $V_{CC}$  returns to nominal levels.

External RAM access is inhibited in a similar manner by forcing  $\overline{E1CON}$  and  $\overline{E2CON}$  to a high level. This level is within 0.2V of the  $V_{BAT}$ .  $\overline{E1CON}$  and  $\overline{E2CON}$  will remain at this level as long as  $V_{CC}$  remains at an out-of-tolerance condition.

When  $V_{CC}$  falls below the level of the battery ( $V_{BAT}$ ), power input is switched from the  $V_{CC}$  pin to the battery and the clock registers and external SRAM are maintained from the attached battery supply. All outputs become high impedance. The  $V_{OUT}$  pin is capable of supplying 100 $\mu$ A of current to the attached memory with less than 0.3V drop under this condition. On power up, when  $V_{CC}$  returns to a nominal value, write protection continues for 200ms (max) by inhibiting  $\overline{E1CON}$  or  $\overline{E2CON}$ .

Table 13. TIMEKEEPER Register Map

Address									Function/Range BCD Format	
	D7	D6	D5	D4	D3	D2	D1	D0		
Fh	10 Years				Year				Year	00-99
Eh	0	0	0	10M	Month				Month	01-12
Dh	0	0	10 Date		Date: Day of Month				Date	01-31
Ch	0	FT	0	0	0	Day of Week			Day	01-7
Bh	0	0	10 Hours		Hours (24 Hour Format)				Hour	00-23
Ah	0	10 Minutes			Minutes				Min	00-59
9h	ST	10 Seconds			Seconds				Sec	00-59
8h	W	R	S	Calibration					Control	
7h	WDS	BMB4	BMB3	BMB2	BMB1	BMB0	RB1	RB0	Watchdog	
6h	AFE	0	ABE	AI 10M	Alarm Month				A Month	01-12
5h	RPT4	RPT5	AI 10 Date		Alarm Date				A Date	01-31
4h	RPT3	0	AI 10 Hour		Alarm Hour				A Hour	00-23
3h	RPT2	Alarm 10 Minutes			Alarm Minutes				A Min	00-59
2h	RPT1	Alarm 10 Seconds			Alarm Seconds				A Sec	00-59
1h	1000 Year				100 Year				Century	00-99
0h	WDF	AF	Y	BL	Y	Y	Y	Y	Flag	

Keys: S = Sign Bit  
 FT = Frequency Test Bit  
 R = Read Bit  
 W = Write Bit  
 ST = Stop Bit  
 0 = Must be set to zero  
 BL = Battery Low Flag  
 BMB0-BMB4 = Watchdog Multiplier Bits

AFE = Alarm Flag Enable Flag  
 RB0-RB1 = Watchdog Resolution Bits  
 WDS = Watchdog Steering Bit  
 ABE = Alarm in Battery Back-Up Mode Enable Bit  
 RPT1-RPT5 = Alarm Repeat Mode Bits  
 WDF = Watchdog flag  
 AF = Alarm flag  
 Y = '1' or '0'

The  $\overline{RST}$  signal also remains active during this time (see Figure 5).

**Note:** Most low power SRAMs on the market today can be used with the M48T212A TIMEKEEPER Controller. There are, however some criteria which should be used in making the final choice of an SRAM to use. The SRAM must be designed in a way where the chip enable input disables all other inputs to the SRAM. This allows inputs to the M48T212A and SRAMs to be Don't Care once  $V_{CC}$  falls below  $V_{PFD}(\min)$ . The SRAM should also guarantee data retention down to  $V_{CC} = 2.0V$ . The chip enable access time must be sufficient to meet the system needs with the chip enable output propagation delays included.

If the SRAM includes a second chip enable pin (E2), this pin should be tied to  $V_{OUT}$ .

If data retention lifetime is a critical parameter for the system, it is important to review the data retention current specifications for the particular SRAMs being evaluated. Most SRAMs specify a data retention current at 3.0V. Manufacturers generally specify a typical condition for room temperature along with a worst case condition (generally at elevated temperatures). The system level requirements will determine the choice of which value to use.

The data retention current value of the SRAMs can then be added to the  $I_{BAT}$  value of the M48T212A to determine the total current requirements for data retention. The available battery capacity can then be divided by this current to determine the amount of data retention available.

For a further more detailed review of lifetime calculations, please see Application Note AN1012.

### TIMEKEEPER REGISTERS

The M48T212A offers 16 internal registers which contain TIMEKEEPER, Alarm, Watchdog, Flag, and Control data. These registers are memory locations which contain external (user accessible) and internal copies of the data (usually referred to as BiPORT™ TIMEKEEPER cells).

The external copies are independent of internal functions except that they are updated periodically by the simultaneous transfer of the incremented internal copy. TIMEKEEPER and Alarm Registers store data in BCD. Control, Watchdog and Flags Registers store data in Binary Format.

### CLOCK OPERATIONS

#### Reading the Clock

Updates to the TIMEKEEPER registers should be halted before clock data is read to prevent reading data in transition. Because the BiPORT TIMEKEEPER cells in the RAM array are only data registers, and not the actual clock counters, updating the registers can be halted without disturbing the clock itself.

Updating is halted when a '1' is written to the READ bit, D6 in the Control Register (8h). As long as a '1' remains in that position, updating is halted. After a halt is issued, the registers reflect the count; that is, the day, date, and time that were current at the moment the halt command was issued.

All of the TIMEKEEPER registers are updated simultaneously. A halt will not interrupt an update in progress. Updating occurs 1 second after the READ bit is reset to a '0'.

#### Setting the Clock

Bit D7 of the Control Register (8h) is the WRITE bit. Setting the WRITE bit to a '1', like the READ bit, halts updates to the TIMEKEEPER registers. The user can then load them with the correct day, date, and time data in 24 hour BCD format (see Table 13).

Resetting the WRITE bit to a '0' then transfers the values of all time registers (Fh-9h, 1h) to the actual TIMEKEEPER counters and allows normal operation to resume. After the WRITE bit is reset, the next clock update will occur one second later.

**Note:** Upon power-up following a power failure, the READ bit will automatically be set to a '1'. This will prevent the clock from updating the TIME-

KEEPER registers, and will allow the user to read the exact time of the power-down event.

Resetting the READ Bit to a '0' will allow the clock to update these registers with the current time. The WRITE Bit will be reset to a '0' upon powerup.

#### Stopping and Starting the Oscillator

The oscillator may be stopped at any time. If the device is going to spend a significant amount of time on the shelf, the oscillator can be turned off to minimize current drain on the battery. The STOP bit is located at Bit D7 within the Seconds Register (9h). Setting it to a '1' stops the oscillator. When reset to a '0', the M48T212A oscillator starts within one second.

**Note:** It is not necessary to set the WRITE bit when setting or resetting the FREQUENCY TEST bit (FT) or the STOP bit (ST).

### SETTING ALARM CLOCK REGISTERS

Address locations 6h-2h contain the alarm settings. The alarm can be configured to go off at a prescribed time on a specific month, date, hour, minute, or second or repeat every year, month, day, hour, minute, or second. It can also be programmed to go off while the M48T212A is in the battery back-up to serve as a system wake-up call.

Bits RPT5-RPT1 put the alarm in the repeat mode of operation. Table 12 shows the possible configurations. Codes not listed in the table default to the once per second mode to quickly alert the user of an incorrect alarm setting.

When the clock information matches the alarm clock settings based on the match criteria defined by RPT5-RPT1, the AF (Alarm Flag) is set.

If AFE (Alarm Flag Enable) is also set, the alarm condition activates the  $\overline{\text{IRQ/FT}}$  pin. The  $\overline{\text{IRQ/FT}}$  output is cleared by a read to the Flags register as shown in Figure 9. A subsequent read of the Flags register will reset the Alarm Flag (D6; Register 0h).

The  $\overline{\text{IRQ/FT}}$  pin can also be activated in the battery back-up mode. The  $\overline{\text{IRQ/FT}}$  will go low if an alarm occurs and both ABE (Alarm in Battery Back-up Mode Enable) and AFE are set. The ABE and AFE bits are reset during power-up, therefore an alarm generated during power-up will only set AF. The user can read the Flag Register at system boot-up to determine if an alarm was generated while the M48T212A was in the deselect mode during power-up. Figure 10 illustrates the back-up mode alarm timing.

Figure 10. Back-Up Mode Alarm Waveforms

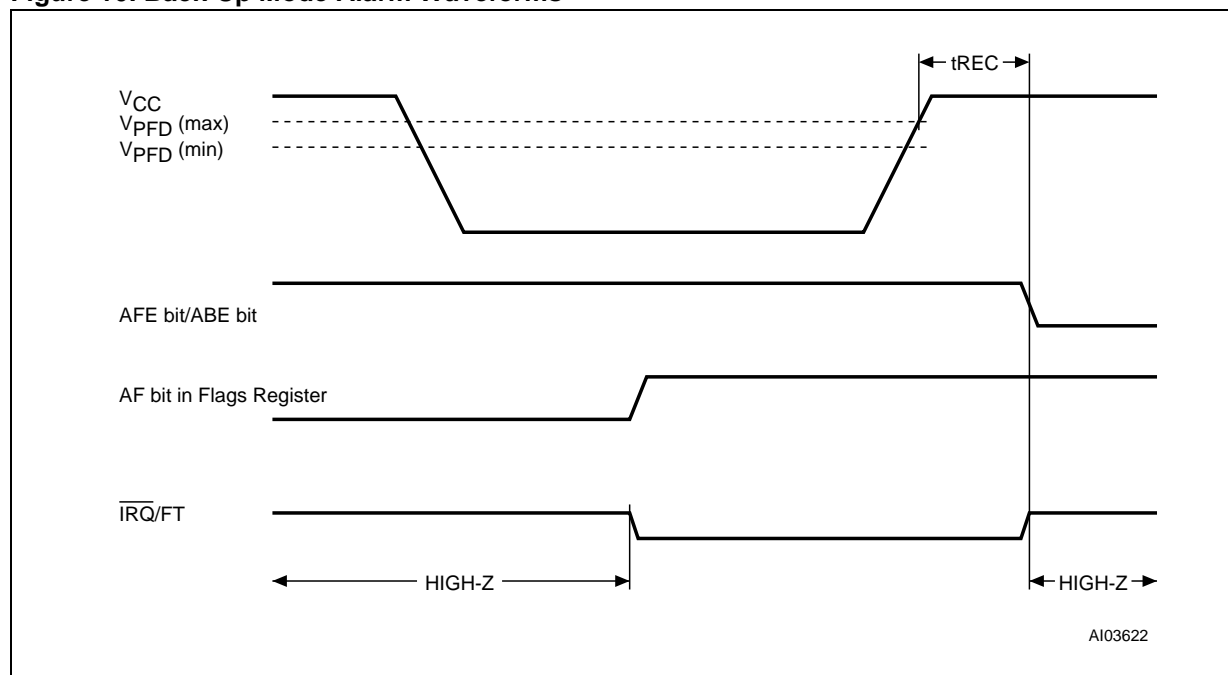

### WATCHDOG TIMER

The watchdog timer can be used to detect an out-of-control microprocessor. The user programs the watchdog timer by setting the desired amount of time-out into the Watchdog Register, address 7h.

Bits BMB4-BMB0 store a binary multiplier and the two lower order bits RB1-RB0 select the resolution, where 00=1/16 second, 01=1/4 second, 10=1 second, and 11=4 seconds. The amount of time-out is then determined to be the multiplication of the five bit multiplier value with the resolution. (For example: writing 00001110 in the Watchdog Register =  $3 \times 1$  or 3 seconds). If the processor does not reset the timer within the specified period, the M48T212A sets the WDF (Watchdog Flag) and generates a watchdog interrupt or a microprocessor reset.

The most significant bit of the Watchdog Register is the Watchdog Steering Bit (WDS). When set to a '0', the watchdog will activate the  $\overline{IRQ/FT}$  pin when timed-out. When WDS is set to a '1', the watchdog will output a negative pulse on the  $\overline{RST}$  pin for 40 to 200 ms. The Watchdog register and the FT bit will reset to a '0' at the end of a Watchdog time-out when the WDS bit is set to a '1'.

The watchdog timer can be reset by two methods:

1. a transition (high-to-low or low-to-high) can be applied to the Watchdog Input pin (WDI) or
2. the microprocessor can perform a write of the Watchdog Register.

The time-out period then starts over. The WDI pin should be tied to  $V_{SS}$  if not used. The watchdog will be reset on each transition (edge) seen by the WDI pin. In the order to perform a software reset of the watchdog timer, the original time-out period can be written into the Watchdog Register, effectively restarting the count-down cycle.

Should the watchdog timer time-out, and the WDS bit is programmed to output an interrupt, a value of 00h needs to be written to the Watchdog Register in order to clear the  $\overline{IRQ/FT}$  pin. This will also disable the watchdog function until it is again programmed correctly. A read of the Flags Register will reset the Watchdog Flag (Bit D7; Register 0h).

The watchdog function is automatically disabled upon power-up and the Watchdog Register is cleared. If the watchdog function is set to output to the  $\overline{IRQ/FT}$  pin and the frequency test function is activated, the watchdog function prevails and the frequency test function is denied.

### V<sub>CC</sub> SWITCH OUTPUT

V<sub>CCSW</sub> output goes low when V<sub>OUT</sub> switches to V<sub>CC</sub> turning on a customer supplied P-Channel MOSFET (see Figure 3). The Motorola MTD20P06HDL is recommended. This MOSFET in turn connects V<sub>OUT</sub> to a separate supply when the current requirement is greater than I<sub>OUT1</sub> (see Table 7). This output may also be used simply to indicate the status of the internal battery switch-over comparator, which controls the source (V<sub>CC</sub> or battery) of the V<sub>OUT</sub> output.

### POWER-ON RESET

The M48T212A continuously monitors V<sub>CC</sub>. When V<sub>CC</sub> falls to the power fail detect trip point, the  $\overline{\text{RST}}$  pulls low (open drain) and remains low on power-up for 40 to 200ms after V<sub>CC</sub> passes V<sub>PF<sub>DD</sub></sub>. The  $\overline{\text{RST}}$  pin is an open drain output and an appropriate pull-up resistor to V<sub>CC</sub> should be chosen to control rise time.

**Note:** If the  $\overline{\text{RST}}$  output is fed back into either of the  $\overline{\text{RSTIN}}$  inputs (for a microprocessor with a bi-directional reset) then a 1k $\Omega$  (max) pull-up resistor is recommended.

### Reset Inputs ( $\overline{\text{RSTIN1}}$ & $\overline{\text{RSTIN2}}$ )

The M48T212A provides two independent inputs which can generate an output reset. The duration and function of these resets is identical to a reset generated by a power cycle. Table 14 and Figure 12 illustrate the AC reset characteristics of this function. During the time  $\overline{\text{RST}}$  is enabled (t<sub>R1HRH</sub> & t<sub>R2HRH</sub>), the Reset Inputs are ignored.

**Note:**  $\overline{\text{RSTIN1}}$  and  $\overline{\text{RSTIN2}}$  are each internally pulled up to V<sub>CC</sub> through a 100k $\Omega$  resistor.

### Calibrating the Clock

The M48T212A is driven by a quartz controlled oscillator with a nominal frequency of 32,768 Hz. The devices are tested not to exceed  $\pm 35$  ppm (parts per million) oscillator frequency error at 25°C, which equates to about  $\pm 1.53$  minutes per month. When the Calibration circuit is properly employed, accuracy improves to better than +1/-2 ppm at 25°C.

The oscillation rate of crystals changes with temperature. The M48T212A design employs periodic counter correction. The calibration circuit adds or subtracts counts from the oscillator divider circuit at the divide by 256 stage, as shown in Figure 11. The number of times pulses which are blanked (subtracted, negative calibration) or split (added, positive calibration) depends upon the value loaded into the five Calibration bits found in the Control Register. Adding counts speeds the clock up, subtracting counts slows the clock down.

The Calibration bits occupy the five lower order bits (D4-D0) in the Control Register 8h. These bits can be set to represent any value between 0 and

31 in binary form. Bit D5 is a Sign bit; '1' indicates positive calibration, '0' indicates negative calibration. Calibration occurs within a 64 minute cycle. The first 62 minutes in the cycle may, once per minute, have one second either shortened by 128 or lengthened by 256 oscillator cycles.

If a binary '1' is loaded into the register, only the first 2 minutes in the 64 minute cycle will be modified; if a binary 6 is loaded, the first 12 will be affected, and so on.

Therefore, each calibration step has the effect of adding 512 or subtracting 256 oscillator cycles for every 125,829,120 actual oscillator cycles, that is +4.068 or -2.034 ppm of adjustment per calibration step in the calibration register. Assuming that the oscillator is running at exactly 32,768 Hz, each of the 31 increments in the Calibration byte would represent +10.7 or -5.35 seconds per month which corresponds to a total range of +5.5 or -2.75 minutes per month.

Two methods are available for ascertaining how much calibration a given M48T212A may require. The first involves setting the clock, letting it run for a month and comparing it to a known accurate reference and recording deviation over a fixed period of time. Calibration values, including the number of seconds lost or gained in a given period, can be found in Application Note AN934: TIMEKEEPER Calibration.

This allows the designer to give the end user the ability to calibrate the clock as the environment requires, even if the final product is packaged in a non-user serviceable enclosure. The designer could provide a simple utility that accesses the Calibration byte.

The second approach is better suited to a manufacturing environment, and involves the use of the  $\overline{\text{IRQ/FT}}$  pin. The pin will toggle at 512Hz, when the Stop bit (ST, D7 of 9h) is '0', the Frequency Test bit (FT, D6 of Ch) is '1', the Alarm Flag Enable bit (AFE, D7 of 6h) is '0', and the Watchdog Steering bit (WDS, D7 of 7h) is '1' or the Watchdog Register (7h = 0) is reset.

Any deviation from 512 Hz indicates the degree and direction of oscillator frequency shift at the test temperature. For example, a reading of 512.010124 Hz would indicate a +20 ppm oscillator frequency error, requiring a -10 (WR001010) to be loaded into the Calibration Byte for correction. Note that setting or changing the Calibration Byte does not affect the Frequency test output frequency.

The  $\overline{\text{IRQ/FT}}$  pin is an open drain output which requires a pull-up resistor to V<sub>CC</sub> for proper operation. A 500-10k $\Omega$  resistor is recommended in order to control the rise time. The FT bit is cleared on power-up.

**Table 14. Reset AC Characteristics**(T<sub>A</sub> = 0 to 70°C; V<sub>CC</sub> = 3V to 3.6V)

Symbol	Parameter	Min	Max	Unit
t <sub>R1</sub> <sup>(1)</sup>	$\overline{\text{RSTIN1}}$ Low to $\overline{\text{RSTIN1}}$ High	200		ns
t <sub>R2</sub> <sup>(2)</sup>	$\overline{\text{RSTIN2}}$ Low to $\overline{\text{RSTIN2}}$ High	100		ms
t <sub>R1HRH</sub> <sup>(3)</sup>	$\overline{\text{RSTIN1}}$ High to $\overline{\text{RST}}$ High	40	200	ms
t <sub>R2HRH</sub> <sup>(3)</sup>	$\overline{\text{RSTIN2}}$ High to $\overline{\text{RST}}$ High	40	200	ms

Note: 1. Pulse width less than 50ns will result in no  $\overline{\text{RESET}}$  (for noise immunity).

2. Pulse width less than 20ms will result in no  $\overline{\text{RESET}}$  (for noise immunity).

3. C<sub>L</sub> = 5pF (see Figure 4).

**Table 15. Crystal Electrical Characteristics (Externally Supplied)**

Symbol	Description	Min	Typ	Max	Unit
f <sub>O</sub>	Resonant Frequency		32,768		kHz
R <sub>S</sub>	Series Resistance		50	70	kΩ
C <sub>L</sub>	Load Capacitance		12.5		pF

Note: Load capacitors are integrated within the M48T212A. Circuit board layout considerations for the 32kHz crystal of minimum trace lengths and isolation from RF generating signals should be taken into account. ST recommends the KDS DT-38 Tuning Fork Type quartz crystal for all temperature operations. KDS can be contacted at 913-491-6825 or at <http://www.kdsj.co.jp> for further information on this crystal type.

### BATTERY LOW WARNING

The M48T212A automatically performs battery voltage monitoring upon power-up and at factory-programmed time intervals of approximately 24 hours. The Battery Low (BL) bit, Bit D4 of Flags Register 0h, will be asserted if the battery voltage is found to be less than approximately 2.5V. The BL bit will remain asserted until completion of battery replacement and subsequent battery low monitoring tests, either during the next power-up sequence or the next scheduled 24-hour interval.

If a battery low is generated during a power-up sequence, this indicates that the battery is below approximately 2.5 volts and may not be able to maintain data integrity in the SRAM. Data should be considered suspect and verified as correct. A fresh battery should be installed.

If a battery low indication is generated during the 24-hour interval check, this indicates that the battery is near end of life. However, data is not compromised due to the fact that a nominal V<sub>CC</sub> is supplied. In order to insure data integrity during

subsequent periods of battery back-up mode, the battery should be replaced. The battery should be replaced with V<sub>CC</sub> powering the device to avoid data loss.

The M48T212A only monitors the battery when a nominal V<sub>CC</sub> is applied to the device. Thus applications which require extensive durations in the battery back-up mode should be powered-up periodically (at least once every few months) in order for this technique to be beneficial.

Additionally, if a battery low is indicated, data integrity should be verified upon power-up via a checksum or other technique.

**Note:** Battery Low warning is only valid when using a 3V button cell battery. Use a super capacitor for back-up supply causes the BL flag to be invalid.

### INITIAL POWER-ON DEFAULTS

Upon application of power to the device, the following register bits are set to a '0' state: WDS, BMB0-BMB4, RB0-RB1, AFE, ABE, W and FT (See Table 16).

Figure 11. Calibration Waveform

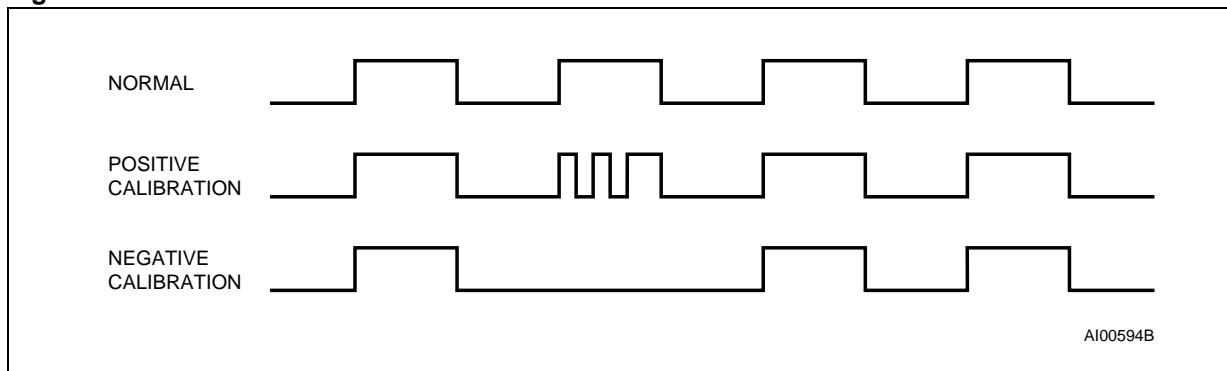
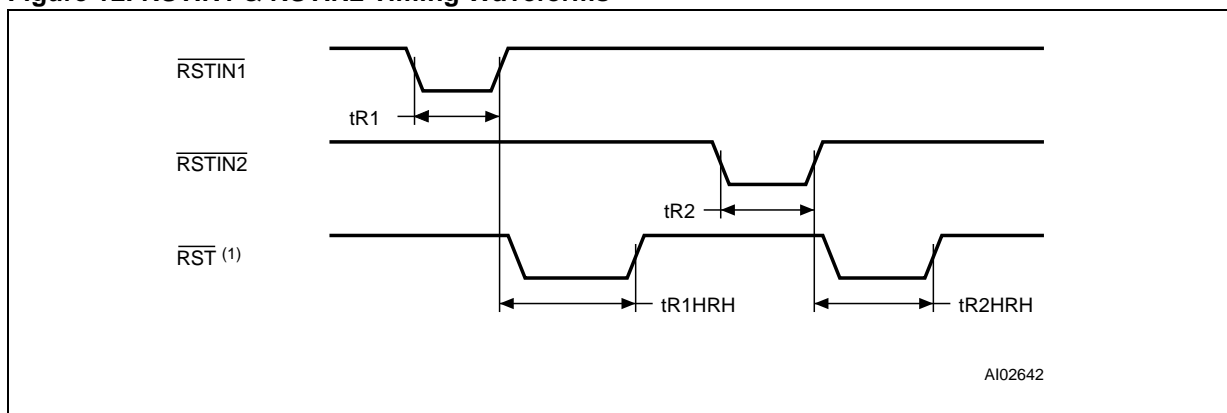

Figure 12.  $\overline{\text{RSTIN1}}$  &  $\overline{\text{RSTIN2}}$  Timing Waveforms



Note: 1. With pull-up resistor.

Table 16. Default Values

Condition	W	R	FT	AFE	ABE	WATCHDOG Register <sup>(1)</sup>
Initial Power-up (Battery Attach for SNAPHAT) <sup>(2)</sup>	0	0	0	0	0	0
RESET <sup>(3)</sup>	0	0	0	0	0	0
Power-down <sup>(4)</sup>	0	1	0	1	1	0
Subsequent Power-up	0	1	0	0	0	0

Note: 1. WDS, BMB0-BMB4, RB0, RB1.  
 2. State of other control bits undefined.  
 3. State of other control bits remains unchanged.  
 4. Assuming these bits set to '1' prior to power-down.



### POWER SUPPLY DECOUPLING AND UNDERSHOOT PROTECTION

Note:  $I_{CC}$  transients, including those produced by output switching, can produce voltage fluctuations, resulting in spikes on the  $V_{CC}$  bus. These transients can be reduced if capacitors are used to store energy, which stabilizes the  $V_{CC}$  bus. The energy stored in the bypass capacitors will be released as low going spikes are generated or energy will be absorbed when overshoots occur.

A ceramic bypass capacitor value of  $0.1\mu\text{F}$  is recommended in order to provide the needed filtering. In addition to transients that are caused by normal SRAM operation, power cycling can generate negative voltage spikes on  $V_{CC}$  that drive it to values below  $V_{SS}$  by as much as one volt. These negative spikes can cause data corruption in the SRAM while in battery backup mode.

To protect from these voltage spikes, ST recommends connecting a schottky diode from  $V_{CC}$  to  $V_{SS}$  (cathode connected to  $V_{CC}$ , anode to  $V_{SS}$ ). (Schottky diode 1N5817 is recommended for through hole and MBR120T3 is recommended for surface mount).

Figure 13. Supply Voltage Protection

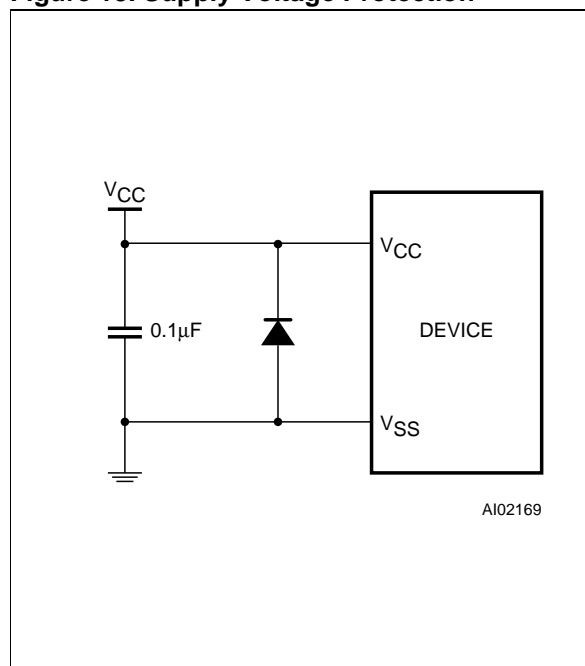

## M48T212A

---

**Table 17. Ordering Information Scheme**

Example:	M48T212A	-85	MH	1	TR
<b>Device Type</b>					
M48T					
<b>Supply Voltage and Write Protect Voltage</b>					
212A = V <sub>CC</sub> = 3.0V to 3.6V; V <sub>PPD</sub> = 2.7V to 3.0V					
<b>Speed</b>					
-85 = 85ns					
<b>Package</b>					
MH = SOH44					
<b>Temperature Range</b>					
1 = 0 to 70 °C					
6 = -40 to 85 °C					
<b>Shipping Method for SOIC</b>					
blank = Tubes					
TR = Tape & Reel					

For a list of available options (Speed, Package, etc...) or for further information on any aspect of this device, please contact the STMicroelectronics Sales Office nearest to you.

**Table 18. Revision History**

Date	Revision Details
October 1999	First Issue
03/01/00	SNAPHAT Battery & Crystal removed Hardware Hookup scheme changed (Figure 3) Back-Up Mode Alarm Waveforms changed (Figure 10) Default Values Table added (Table 16) SOH44 package silhouette, mechanical drawings and mechanical data changed (Figure 14)

Table 19. SOH44 - 44 lead Plastic Small Outline SNAPHAT, Package Mechanical Data

Symb	mm			inches		
	Typ	Min	Max	Typ	Min	Max
A			3.05			0.120
A1		0.05	0.36		0.002	0.014
A2		2.34	2.69		0.092	0.106
B		0.36	0.46		0.014	0.018
C		0.15	0.32		0.006	0.012
D		17.71	18.49		0.697	0.728
E		8.23	8.89		0.324	0.350
e	0.81	–	–	0.032	–	–
H		11.51	12.70		0.453	0.500
L		0.41	1.27		0.016	0.050
$\alpha$		0°	8°		0°	8°
N		44			44	
CP			0.10			0.004

Figure 14. SOH44 - 44 lead Plastic Small Outline SNAPHAT, Package Outline

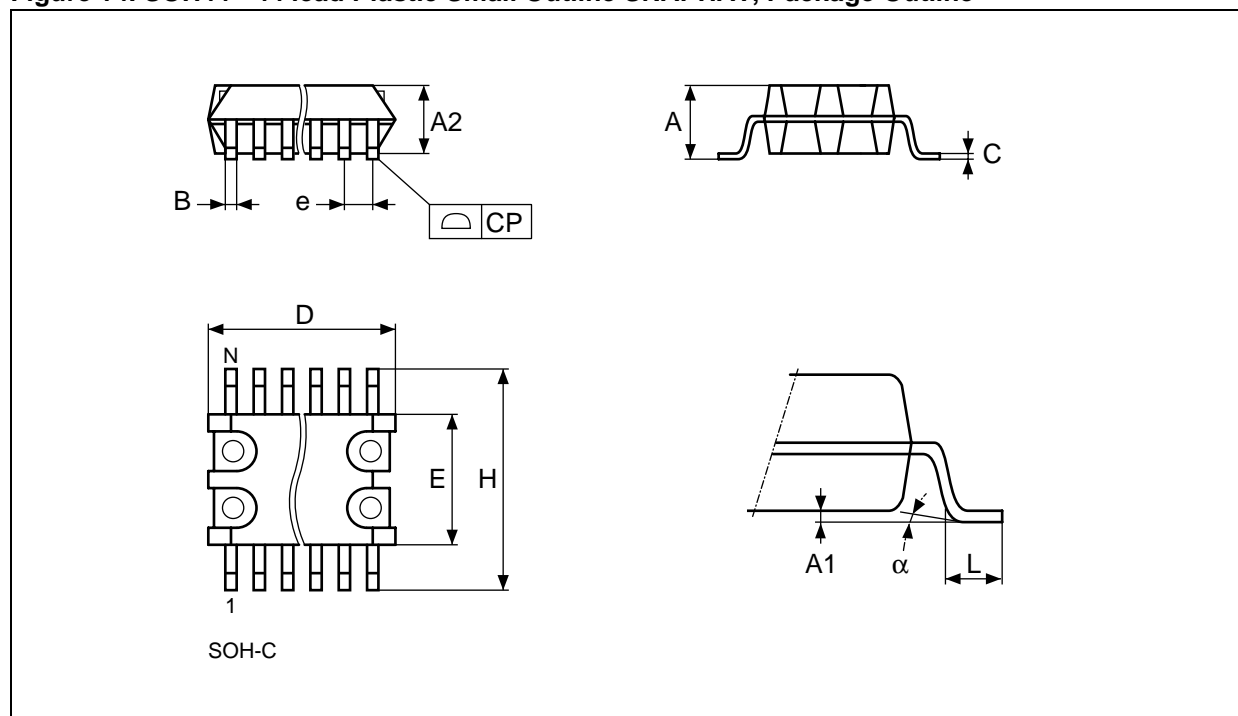

Drawing is not to scale.

Information furnished is believed to be accurate and reliable. However, STMicroelectronics assumes no responsibility for the consequences of use of such information nor for any infringement of patents or other rights of third parties which may result from its use. No license is granted by implication or otherwise under any patent or patent rights of STMicroelectronics. Specifications mentioned in this publication are subject to change without notice. This publication supersedes and replaces all information previously supplied. STMicroelectronics products are not authorized for use as critical components in life support devices or systems without express written approval of STMicroelectronics.

The ST logo is registered trademark of STMicroelectronics  
© 2000 STMicroelectronics - All Rights Reserved

All other names are the property of their respective owners.

STMicroelectronics GROUP OF COMPANIES  
Australia - Brazil - China - Finland - France - Germany - Hong Kong - India - Italy - Japan - Malaysia - Malta - Morocco -  
Singapore - Spain - Sweden - Switzerland - United Kingdom - U.S.A.

<http://www.st.com>