

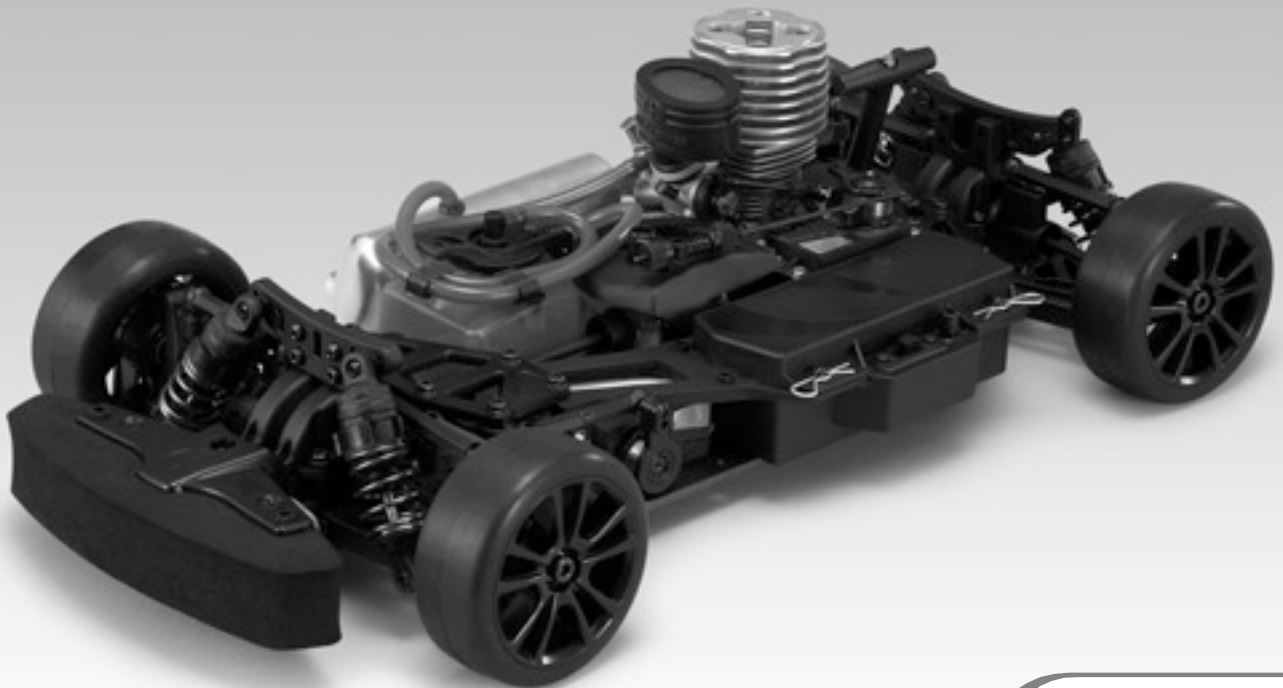

# TOMAHAWK

**1/10 SCALE NITRO POWERED 4WD TOURING CAR SERIES**  
**1:10 引擎動力四驅房車系列**



No.6194-F  
No.6196-F



This radio control model car is not a toy! Before beginning operation, please read this manual thoroughly.

本產品為高性能模型非一般玩具，操作前請詳閱本產品說明書。

The contents are subject to change without prior notice due to product improvements and specification changes.

本套件所附之零件可能跟圖示有所差異。因產品後續之設計研發或功能不斷改善之原因，我們將保留產品規格變更權力，不再另行通知使用者。

## Instruction Manual 操作說明書

### WARRANTY 品質保證事項

Thunder Tiger Corporation guarantees this model kit to be free from defects in both material and workmanship. The total monetary value under warranty will in no case exceed the cost of the original kit purchased. This warranty does not cover any components damaged by use or modification. Part or parts missing from this kit must be reported within 60 days of purchase. No part or parts will be sent under warranty without proof of purchase. To receive part or parts under warranty, the service center must receive a proof of purchase and/or the defective part or parts. Should you find a defective or missing part, contact the authorized Thunder Tiger Service/Distributor nearest you. Under no circumstances can a dealer or distributor accept return of a kit if assembly has started.

本公司對於製造過程中產生之瑕疵，負完全品質保證責任。

保證事項僅限於產品本身與隨產品所附之零配件。

品質保證不包含下列事項

因使用、組裝或調整本產品所發生之損壞。

其他所有非產品本身品質所造成之損壞。



## INTRODUCTION 前言

Thank you for your purchase of this Thunder Tiger product. You should enjoy many hours of fun and excitement from this advanced R/C model. Thunder Tiger strives to bring you the highest level of quality and service we can provide. We race and test our cars around the world to bring you state-of-the-art products.

We offer on-line help on our [www.acehobby.com](http://www.acehobby.com) or [www.thundertiger.com](http://www.thundertiger.com) forum and our product specialists are ready to take your call if you have any technical questions. Please read all instructions and familiarize yourself with the systems and controls of this model before running. Have fun and enjoy the exciting world of R/C!

感謝您購買雷虎科技TOMAHAWK VX / MX引擎四驅房車。雷虎科技以提供最高品質的產品及服務作為持續努力的目標。並藉由參與競賽及重覆測試產品，不斷累積經驗，進而提昇設計及製成品質，期望能呈現給您最頂級之工藝產品。本使用說明書包含了操作本產品前所需注意的重要事項，建議您在開始準備及操作本產品之前，能詳閱此說明書，並熟悉本產品之操控系統。若是您在產品的操作及使用上有任何的疑問，歡迎多加利用我們所提供的24小時諮詢留言版或洽詢雷虎科技授權經銷商。雷虎科技的全球英文網址為[www.thundertiger.com](http://www.thundertiger.com) 中文網址為[www.tiger.com.tw](http://www.tiger.com.tw)，我們將竭誠為您服務！

## CAUTION 注意事項

Thank you for purchasing a Thunder Tiger Product.

**Please read all instructions and familiarize yourself with the products and controls before operation.**

1. This product is not a toy. It is a high performance model product. It is important to familiarize yourself with the model, its manual, and its construction before assembly or operation. A child operating under the supervision of the adults is necessary.
2. Always keep this instruction manual ready at your hand for your assembling and operating reference, even after completing the assembly.
3. Make sure all the screws are properly tightened and all the parts are checked after running the car for a long period of time.
4. For the best performance, it is important to make sure all the moveable parts work free without binding.
5. Do not operate model products in rain, on public roads, near crowds, near airport, or near areas with restricted radio operation.
6. Always keep fuel away from heat and open flame. Only operate in open, well-ventilated area. Store fuel in cool, dry area. Keep the fuel bottle cap tightly closed. Clean up any leak or excess fuel before starting the engine.
7. This product, its parts, and its construction tools can be harmful to your health. Always exercise extreme caution when assembling and/or operating this product. Do not touch any part of the model that rotates.
8. Check your radio frequency with the proper operating frequency of the area or country. Always check to see if there are any modelers operating on the same frequency as yours. Also, check your radio for proper operation before operating a model.

感謝您購買雷虎科技產品，在您開始操作本產品前，請詳閱本產品說明書。

1. 本產品為高性能模型產品非一般玩具，組裝與操作過程皆須由成人陪同。請詳讀此本使用說明書，避免因組裝錯誤與操作不當造成損壞。
2. 請妥善保管此說明書，對於後續維修、操控說明將可提供您協助。
3. 請定時巡檢車輛上之所有螺絲是否鎖緊，零件是否鬆動。
4. 請檢視所有活動部位零件是否不受干涉，可靈動作動，以達到車輛最佳性能。
5. 請勿於雨天、公眾空間、道路、機場附近與其他限制遙控模型活動區域，操控本項產品。
6. 遙控模型專用燃料，具相當高的揮發性與低燃點特性，請您於使用或儲存時遵照使用燃油之相關規定；使用時必須遠離火源，儲藏時必須避免日曬並放置於乾燥陰涼處，以及兒童無法取得處。
7. 此項產品具有相當之危險性，於組裝、調整、操控上的不熟悉都可能造成自身或他人的傷害，當發生這些傷害事件時製造商是可以免除責任的，建議您於初次使用本產品前，先行請教具有相當程度經驗同好或是專業雷虎經銷商與模型專賣店。
8. 請您確認您所在地區對於頻率規定之相關法規，來選用適當的頻率。避免與其他同好使用相同頻率造成失控事件。

## INDEX 索引

- |   |      |  |       |
|---|------|--|-------|
| INTRODUCTION 前言                                     | ▶▶ 1 | FUELLING 燃油的添加                           | ▶▶ 8  |
| IMPORTANT NOTES & WARNING 重要注意事項                    | ▶▶ 2 | PREPARING THE ENGINE FOR STARTING 引擎整備工作 | ▶▶ 8  |
| ITEMS REQUIRED FOR OPERATION 周邊配件                   | ▶▶ 3 | STARTING THE ENGINE 發動引擎                 | ▶▶ 9  |
| UNWRAPPING CONTENTS FROM BOX 束帶的使用                  | ▶▶ 4 | SHOCK ADJUSTMENT 避震器懸吊調整                 | ▶▶ 9  |
| CHARGING THE GLOW PLUG IGNITER 電夾充電方式               | ▶▶ 4 | ENGINE BREAK-IN & ENGINE SETTING 引擎磨合&設定 | ▶▶ 10 |
| PREPARING THE RADIO 遙控器使用準備                         | ▶▶ 4 | STOPPING ENGINE 停止引擎                     | ▶▶ 11 |
| RADIO BATTERY INSTALLATION 遙控器電池安裝                  | ▶▶ 5 | WHEEL AND TIRE PREPARATION 輪胎及輪轂         | ▶▶ 11 |
| RADIO OPERATION 遙控器操作                               | ▶▶ 5 | STORING AND MAINTENANCE 儲存及保養            | ▶▶ 11 |
| OPERATING RADIO STEERING FUNCTION 遙控器設定-轉向          | ▶▶ 5 | 2 SPEED SETUP 2段變速之調整                    | ▶▶ 12 |
| OPERATING RADIO THROTTLE/BRAKE FUNCTION 遙控器設定-油門、煞車 | ▶▶ 6 | BODY CUTTING 車殼剪裁                        | ▶▶ 12 |
| ADJUSTING THE THROTTLE LINKAGE 油門、煞車連桿調整            | ▶▶ 6 | DRIVING TIPS 駕駛的小技巧                      | ▶▶ 13 |
| ADJUSTING CARBURETOR 化油器調整                          | ▶▶ 7 | TROUBLESHOOTING 常見問題與解決辦法                | ▶▶ 14 |

## IMPORTANT NOTES & WARNING 重要注意事項

### FUEL 燃油



1. Choose a fuel from a reputable, brand name company that is approved for car/truck use. Do not use airplane or boat fuels in your car/truck. Never use gasoline in a glow model engine.
  2. Fuel color is for identification purpose only and is not important to performance or durability of your engine.
  3. Always store fuel in a well ventilated place, away from heating devices, open flames, direct sunlight, or batteries. Keep glow fuel away from children. Always keep your fuel bottle closed when not in use.
  4. Do not dispose of fuel or empty fuel containers in a fire. It may possibly cause fire or explosion.
1. 請選擇具品牌知名度且經過認可、標準的遙控車專用燃油。模型專用燃油以甲醇為主，內含硝基甲烷10%~30%，合成或半合成潤滑油約5%~18%，一般車用燃油建議以含20%硝基甲烷比例的燃油，較為適中。請勿使用一般汽車用燃油於模型專用引擎上。
2. 燃油的顏色主要是辨識用，對於引擎的性能及耐久性並無影響。
3. 儲存燃油時請置放於通風良好的地方，遠離熱源、高溫電器用品或蓄電池，並儘量避免陽光直射。燃油不用時請儲藏於幼兒無法接觸之處並請隨時關緊瓶蓋。
4. 勿將燃油及燃油空瓶接近火源，高溫可能會引起爆炸起火的危險。

### ENGINE 引擎

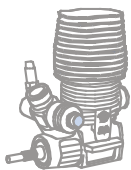

1. For proper engine break-in procedure, please refer to the manual of your engine.
  2. Never run your vehicle without the air filter. If the vehicle will be operated in an area with fine dust, use filter oil or castor oil on the air filter element. It is important that the foam is only moist to trap dirt and allow air passage. With the foam too wet, limited air can pass through; therefore, limiting engine performance.
  3. The parts around engine could be dangerously hot after operation. Do not touch it without any protection!
1. 引擎的磨合步驟，請參考引擎手冊。
2. 引擎沒裝空氣濾清器，請勿發動引擎。在有粉塵的場地操作車輛時，空氣濾清器棉需加入空氣濾清器油或蓖麻油，用以吸附粉塵。空濾油加入空濾棉中需適量。太多，會影響引擎進氣效率，引擎性能會受到限制。太少，粉塵容易進入引擎內部，造成損壞。
3. 車輛操作過後，引擎及排氣管的溫度很高，請勿接觸這些危險部位。

### OPERATION 遙控系統



1. Choose the right place to operate your R/C model. Do not run on public streets or highways. This could cause serious accidents, personal injuries, and/or property damage. Never run R/C models near people or animals. To avoid injury, do not run in confined spaces. Do not run where loud noises can disturb others, such as hospitals and residential areas. Never run indoors. There is a high risk of fire and/or damage.
  2. Inspect your model before operation. Make sure all the screws are properly tightened and all the parts are checked after running the car for a long period of time. Always use fresh batteries for your transmitter and for your receiver to avoid losing control of the model. Always test the brakes and the throttle before starting your engine to avoid losing control of the model.
  3. Check your radio frequency with the proper operating frequency of the area or country. Always check to see if there are any modelers operating on the same frequency as yours. Also, check your radio for proper operation before operating a model.
  4. Do not touch any part of the model that rotates.
1. 請勿於雨天、公眾空間、道路、機場附近與其他限制遙控模型活動區域，操控本項產品。
2. 車輛操作前，請檢查電池電量是否充足，巡檢車輛上之所有螺絲是否鎖緊，零件是否鬆動，並測試煞車及油門裝置是否正常以免發生失控情形。
3. 請您確認您所在地區對於頻率規定之相關法規，來選用適當的頻率。避免與其他同好使用相同頻率造成失控事件。
4. 請勿將手指或任何物品接觸正在轉動的裝置。

### FIRST AID 安全注意事項



1. If you drink nitro fuel by accident, immediately drink large quantities of water and try to induce vomiting. Consult with physician right after then.
  2. If the nitro fuel gets into your eyes, rinse them well with water. Consult with physician right after then.
  3. If the fuel gets onto your skin, wash it well with soap and water.
1. 如果您誤食燃油，請立即喝大量的水稀釋且立即催吐，並立即送醫檢查。
2. 如果眼睛不慎接觸到燃油，請立即以清水沖洗，並送醫檢查。
3. 如果燃油接觸到皮膚，請以肥皂及清水洗淨。

### WARNING 警告



1. Improper operations may cause personal and/or property damage. Thunder Tiger and its distributor have no control over damage resulting from shipping, improper construction, or improper usage.
  2. Thunder Tiger assumes and accepts no responsibility for personal and/or property damages resulting from the use of improper building materials, equipment and operations. By the act of assembling or operating this product, the user accepts all resulting liability. If the buyer is not prepared to accept this liability, then he/she should return this kit in new, unassembled, and unused condition to the place of purchase.
1. 本產品為高性能模型產品非一般玩具，組裝與操作過程皆須由成人陪同。請詳讀此本使用說明書，避免因組裝錯誤與操作不當造成損壞。
2. 此項產品具有相當之危險性，於組裝、調整、操控上的不熟悉都可能造成自身或他人的傷害，當發生這些傷害事件時，製造商及其經銷商是可以免除責任的。建議您於初次使用本產品前，先行請教具有相當程度經驗同好或是專業雷虎經銷商與模型專賣店。

# ITEMS REQUIRED FOR OPERATION 周邊配件



Screw Drivers, Lexan Body Reamer, Hobby Knife, Lexan Scissors.  
十字起子、一字起子、挖孔器、車殼剪、美工刀



Glow Starter w/ Charger  
電夾及充電器



Glow Fuel, Methanol 10% to 30% Nitro 5% to 18% Caster / Synthetic Oil  
模型專用燃料(含10%~30%硝基甲烷、5%~18%潤滑油)

## TOOL INCLUDED



Hex Wrench Set, 1.5mm / 2.0mm / 2.5mm / 3.0mm  
六角扳手, 1.5mm / 2.0mm / 2.5mm / 3.0mm



Fuel Bottle  
加油壺



5-Way Wrench  
六角螺帽套筒扳手



No.2931 Ni-MH battery  
Pack/Flat, 6V/1200mAh 2/3A  
鎳氫充電電池包



No.2932 Ni-MH battery  
Pack/Hump, 6V/1200mAh 2/3A  
鎳氫充電電池包



\*AA Rechargeable Ni-MH  
battery 4 pieces for receiver  
接收機用電池



AA Alkaline dry batteries 8  
pieces for transmitter  
發射機用電池

### Note:

Battery life is short when using Alkaline batteries. For safety, we recommend using Alkaline batteries for only 30 minutes before testing; mostly changing. Battery strength affects braking power and radio range. If voltage drops while running the car, you will loose control and destroy your car! This is **NOT** covered under warranty. To increase run time, upgrade receiver battery to a 5-cell flat /hump pack (TT#2931 Flat , TT#2932 Hump). But, the most important step you can make, "is to always use fully charged or fresh batteries when running your car".

### 註:

一般碳鋅或鹼性乾電池的使用壽命有限，為了安全起見，我們建議玩家能使用電池蓄電力較佳及具有較高電流輸出特性之鎳氫充電電池，可有效延長產品操作時間並大幅增加煞車制動力以及增強遙控操作距離來確保產品操作之安全性。請注意！玩家操控本模型前請先確認安裝符合本產品需求且充電完全之電池。如玩家因為使用充電量不足之電池操作本產品而導致失控，造成任何財產及人身之損害並不在本公司之保固及賠償範圍之內！如欲選購高容量之鎳氫充電電池包，請參考雷虎網站之產品資訊或依需求選購TT#2931 5-Cell 6V Hump 或 TT#2932 5-Cell 6V Flat 鎳氫充電電池包。

## 1 UNWRAPPING CONTENTS FROM BOX 束帶的使用

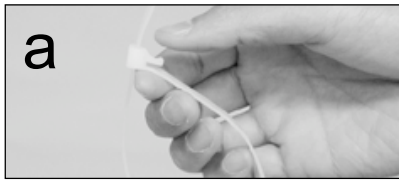

- Contents of the box are secured with reusable zip-ties. To unlock zip-tie, press on the small lever.
- Pull on the zip-tie while keeping the small lever pressed. Pull the zip-tie out completely.

束帶為可活動拆卸式，操作方式如圖示

## 2 CHARGING THE GLOW PLUG IGNITER 電夾充電方式



- Plug the charger into an AC outlet, and then pull on the igniter lever to accept the charging adapter.
- At this point, the small red LED indicator on the charger should light up indicating the charging sequence is in progress.
- When the charging complete, pull on the glow plug igniter lever to unplug the glow igniter. Charge the new glow plug igniter for 16 to 24 hours on the first charge. For subsequent charges, charge it about 12 hours before next use.

### NOTE:

If the igniter gets warm or hot during the charge, unplug the igniter from charger immediately. A warm / hot igniter means the igniter is overcharged. Overcharging can damage the internal battery in the igniter; thus, shortening its life.

- 將充電器插入家用110V插座中，再接上電夾
- 充電過程中，紅色LED燈會保持亮的狀態，如不亮表示為短路，電池無法充電
- 充電完成，將充電器自插座拔下，再分開電夾；新電夾首次充電時間需16到20小時，之後只需充大約12小時即可

### 注意：

充電過程中，電夾電池如出現高溫現象(40~45°C)，表示已過度充電，需立即停止充電。過度充電容易造成電池損壞，更可能產生爆炸起火，請謹慎使用。

## 3 PREPARING THE RADIO 遙控器使用準備

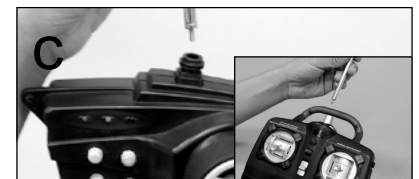
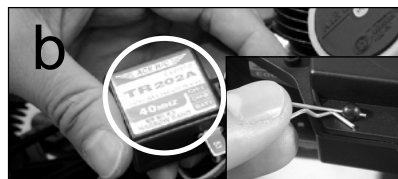
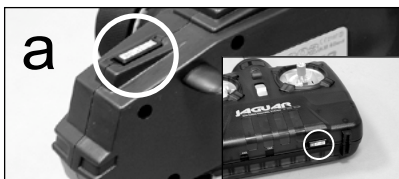

- Check the frequency printed on the transmitter crystal.
- Remove the radio receiver from box. Check the frequency printed on the receiver crystal, and make sure it matches with the transmitter crystal. Make sure no one will operate on the same frequency when you are. When there is a radio glitch, it will most likely be caused by improper crystal, damaged crystal, or people operating on the same frequency. Ensure all wires are securely connected to the receiver:

**steering servo connector plug - into the channel 1 slot** 連接孔1 (CH1)—轉向伺服機

**throttle servo connector plug - into the channel 2 slot** 連接孔2 (CH2)—油門伺服機

**battery switch connector plug - into battery slot.** 電池連接孔 (BATT)—接收機電池

Then thread the receiver antenna/wire through the antenna mount. Thread the receiver antenna/wire all the way through the antenna tube and install the antenna tube onto the mount. After checking, place the receiver back in the box and secure the receiver box top.

- Install the antenna into transmitter.
- 檢查發射機頻率。
- 檢查接收機晶體頻率，確認發射機與接收機頻率是否相同。大部份遙控器會失靈可能都是頻率造成或附近有人使用相同的操控頻率。並確認所有的電子接線都牢固，且依序連結在接收機的連結插孔，確認完畢後，將接收機放回接收機盒並且安全的固定好。
- 裝上發射機天線。

## 4 RADIO BATTERY INSTALLATION 遙控器電池安裝

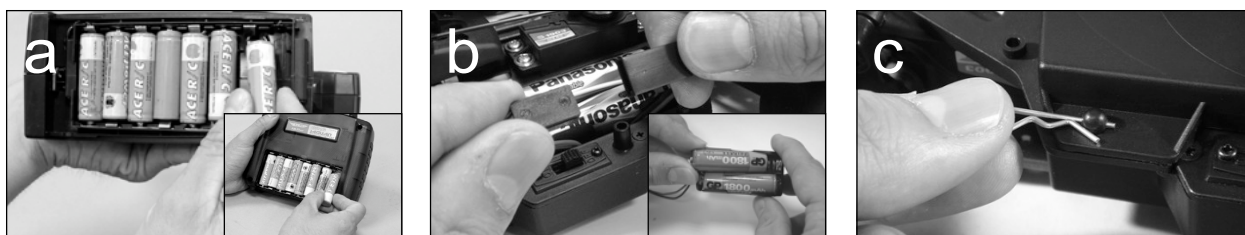

- Install 8 AA size alkaline batteries into transmitter.
  - Install 4 AA size alkaline batteries in receiver battery box to the receiver switch.
  - Install the battery into the receiver box, secure the box with a body clip.
- 安裝8顆3號電池於發射機上，請注意正負極正確安裝方向。
  - 安裝4顆3號接收機電池於電池盒上，並連接接收機電源線、開關線，請注意正、負極正確安裝方向。
  - 將接收機電池安裝於接收盒中並使用R型插銷固定。

## 5 RADIO OPERATION 遙控器操作

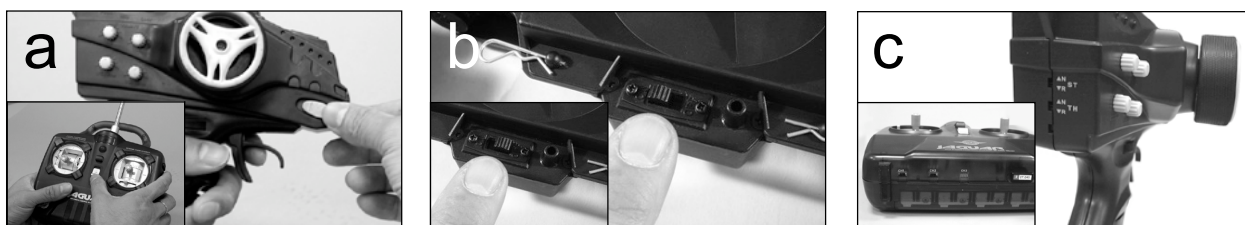

- When turning radio on, first turn on the transmitter.
  - Then, turn on the receiver. When turning off, first turn the receiver off, then the transmitter off.
  - To reverse the functions of servos, use the small, white servo reverse switches located on side of the pistol transmitter (or the inset servo reverse switches located at the bottom of the stick transmitter). To trim the servos on pistol transmitter, use the trim switches on side of the steering wheel (the ST. trims steering, and the TH trims throttle/brake). On a stick transmitter, the trim levers are located accordingly around the sticks.
  - For more details, please check the transmitter instruction manual.
- 先開啓發射機電源。
  - 接著開啓接收機電源。電源的關閉則是相反的順序，先關接收機電源，再關發射機電源。
  - 伺服機的正逆轉開關，槍型發射機在左側(桿型發射機在底部)。
  - 更詳細的使用說明，請參考遙控器使用說明。

## 6 OPERATING RADIO STEERING FUNCTION 遙控器設定－轉向

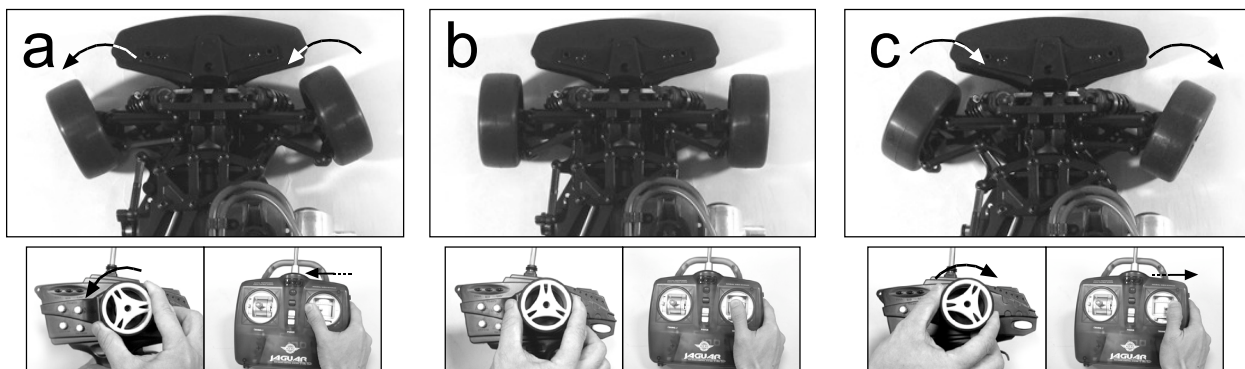

- Check the radio steering functions. With the radio transmitter and receiver on, turn the steering wheel / stick to the left. The front tires/wheels should turn left accordingly. If not, flip the steering servo reverse switch.
  - Return the steering wheel / stick to neutral. The front tires/wheels should point straight forward. If not, use the steering trim lever to correct it.
  - Turn the steering wheel / stick to the right. The front tires/wheels should turn right accordingly.
- 確認轉向功能。打開發射機及接收機電源，方向轉左邊時，輪胎將朝左邊，若方向不一致，請調整方向的正逆轉開關。
  - 方向舵(桿)回中立點時，前輪應筆直向前，若有偏差，請調整方向舵(桿)微調旋鈕。
  - 方向舵(桿)轉向右邊時，前輪應轉向右邊。

## 7 OPERATING RADIO THROTTLE/ BRAKE FUNCTION 遙控器設定－油門、煞車

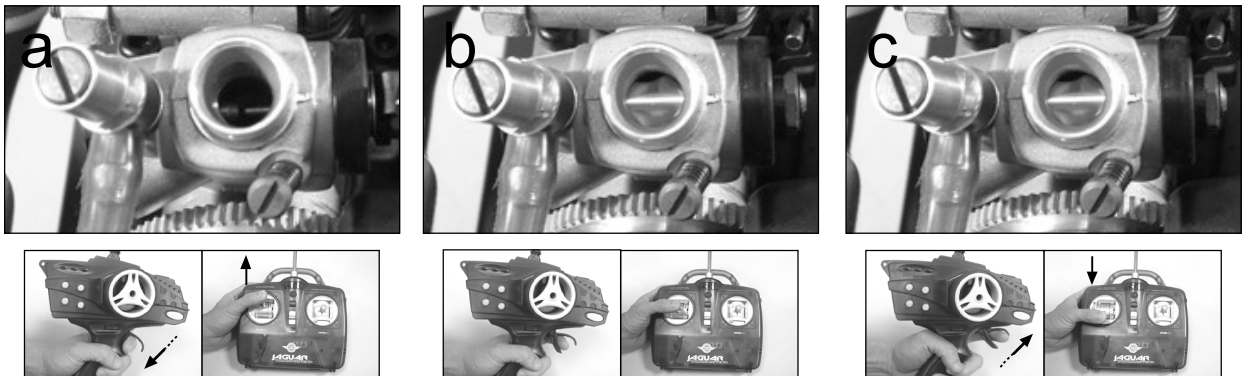

- Check the radio throttle/brake functions. With the radio transmitter and receiver on, pull the trigger / push the stick forward. The carburetor should be fully opened and the brake disengaged. To reverse this function, flip the throttle/brake servo reverse switch.
  - Return the trigger / stick to neutral. The carburetor should be closed to a point where the idle has been set (see step 8 for settings), and the brake still disengaged. If not, use the throttle/brake trim lever to correct it.
  - Push the trigger / pull the stick backward. The carburetor opening should still be the same at neutral, throttle spring compressed slightly, and the brake engaged.
- 確認油門、煞車功能。請先將發射機與接收機電源開關打開，以檢查油門、煞車作動是否正常作動。將油門板機(桿)向內拉上推到底時，化油器應完全開啓，煞車脫離(可輕輕轉動輪子，確認煞車是否完全脫離)，若方向不一致，請調整油門的正逆轉開關。
  - 將油門板機(桿)推回中立點時，化油器應關閉至定點，煞車仍為脫離狀態；若狀態有所偏差，請調整油門微調鈕。(油門、煞車連桿的正確設定，請參考步驟8)
  - 油門板機(桿)向煞車方向推時，化油器應關閉至定點，但煞車須為鎖死狀態。

## 8 ADJUSTING THROTTLE / BRAKE LINKAGE 油門及煞車連桿調整

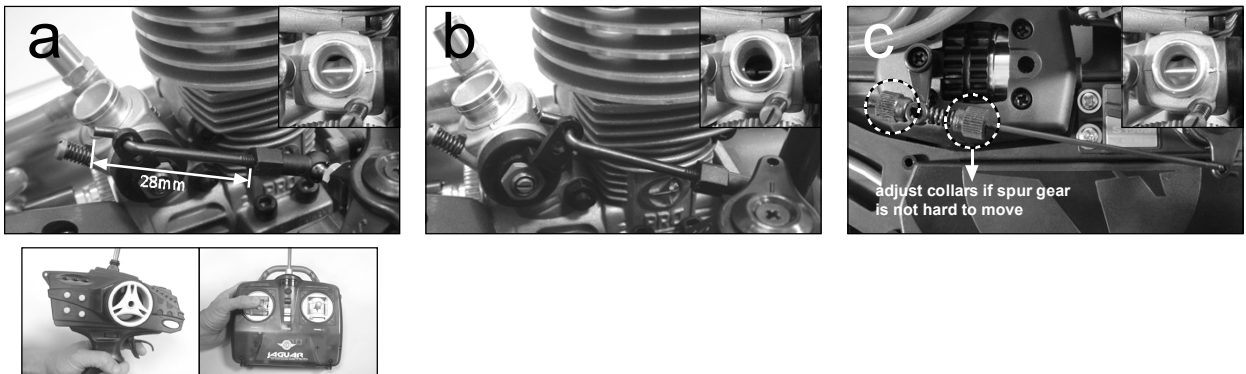

- Idle:** To set the throttle/brake linkage, first the radio should be on ( but do not start the engine)and the servo is at neutral position. The factory setup of throttle linkage is about 28mm.(see picture) If it is not, please adjust the linkage to the proper length. The carburetor opening should be in the idle position. (almost closed, but remain about 0.5~1mm opening inside the carburetor)
  - Full throttle:** Now pull the full throttle. The brakes should disengage immediately. The carburetor should be fully open. If the carburetor is not fully open, adjust the throttle linkage into 28mm (see above) to get the carburetor fully open. You may also adjust your throttle trim according to your radio's instructions.
  - Brake:** Push the trigger / pull the tick backward. The carburetor opening should be in the idle position. (almost closed, but remain about 0.5~1mm opening inside the carburetor), but the spur gear will be hard to move. If it is not engaged, adjust the collars (next to the spring) or setup in your radio to get the brake to engage properly. Be ware that the servo spring should not be completely compressed.
- 怠速：設定油門與煞車連桿，第一步驟應先確認發射機及接收機電源皆已開啓，且伺服機位置與發射機油門撥桿應位於中立點。原廠油門連桿設定為28mm(見圖示)，如果連桿長度不正確，請取下連桿重新調整。此時化油器應該幾乎呈現關閉狀態(引擎怠速點為油門尚留有0.5~1mm的開口)
  - 全油門：將油門全部開啓，此時煞車不應該咬合，此時化油器應該全部開啓。如果化油器油門不正確，請取下油門連桿重新調整，或是調整發射機上的油門微調來調整油門(各家廠牌功能不一，請以發射機說明書指示為依據)。
  - 煞車：煞車時，化油器應該跟怠速狀態一樣(引擎怠速點為油門尚留有0.5~1mm的開口)，且煞車應該立即咬合。如果煞車沒有立即咬合，請調整煞車連桿上的塑膠軸環(靠近彈簧那一個)或是調整發射機上的煞車微調來調整煞車的咬合度(各家廠牌功能不一，請以發射機說明書指示為依據)。請注意油門伺服機連桿的彈簧不可受到完全壓縮!



# 9 ADJUSTING CARBURETOR 化油器調整

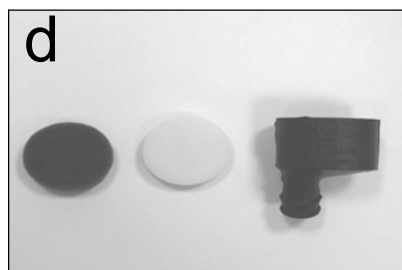
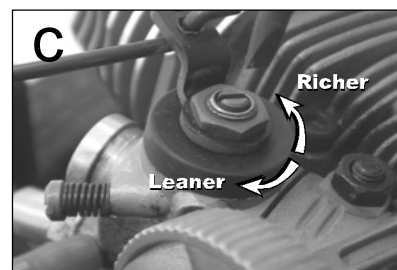
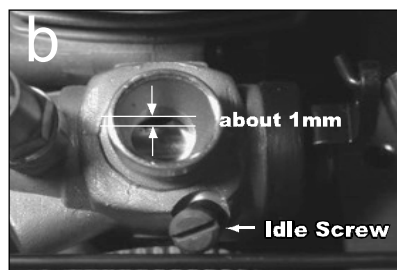
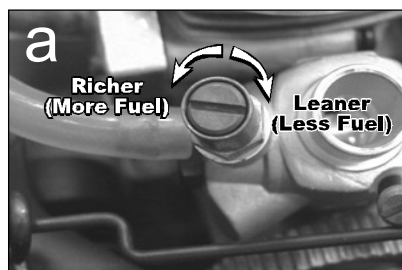

- To set the high speed needle:** (large needle sticking out from the carburetor body), turn the screw as pictured. Initial high speed needle setting should be 3~3.5 turns (close the needle completely, then back out 3~3.5 turns). Clockwise turn will provide leaner setting (lower fuel to air mixture), and counterclockwise turn will provide richer setting (higher fuel to air mixture).
- To set the carburetor idle:** (small needle sticking out from the carburetor body), turn the screw as pictured. Initial idle setting should leave 1mm carburetor gap. Clockwise turn will provide higher idle (larger carburetor opening), and counterclockwise turn will provide lower idle (smaller carburetor opening). For more details about the engine setting, please refer to ENGINE BREAK-IN/SETTING procedures to properly set the engine.
- To set the low speed needle:** (The low-speed mixture screw is located in the end of the carburetor). turn the screw as pictured. This screw controls how much fuel enters the engine at idle and low throttle. This adjustment will smooth the idle and improve the acceleration to mid speed. Make this adjustment with the throttle closed, after setting the idle. Turn the screw clockwise gently until it bottoms out. DO NOT over tighten. Now turn the low-speed mixture screw counter-clock 6 1/2 turns.
- Remove the outer foam from filter and make it moist evenly with a few drops of fuel. Put the filter in a plastic bag and knead it until the foam is saturated, but not soaked.
- Finally, make sure the air cleaner boot is securely fastened with a zip-tie.

Never run your vehicle without the air filter. If the vehicle will be operated in an area with fine dust, use filter oil or castor oil instead of fuel. It is important that the foam is only moist to trap dirt and allow air passage. With the foam too wet, limited air can pass through; therefore, limiting engine performance.

- 高速油針調整：**調整高速油針（突出於化油器本體之較大螺絲），如圖示。於調整前應先保持油針於開啓3~3.5圈的位置（油針完全鎖緊後再鬆開3~3.5圈）。高速油針順時針旋轉，化油器將會呈現較為貧油設定；逆時針旋轉將會呈現較為富油設定。請參考引擎使用手冊來設定您愛車的引擎。
- 怠速設定：**設定引擎怠速轉速用螺絲，突出於化油器本體之較小螺絲（如b圖示），於調整前注意化油器應保持1mm的開口。怠速螺絲順時針旋轉，怠速轉速提高；逆時針旋轉，怠速轉速降低。請參考引擎磨合建議來設定您愛車的引擎。
- 低速油針調整：**調整低速油針時需卸上半部車殼（低速油針位於化油器本體末端），如c圖示。於調整前應先保持油針於開啓6.5圈的位置（油針完全鎖緊後再鬆開6.5圈）。正確調整此油針可讓怠速與中低速更加順暢，調整此油針時需將油門關閉，以及怠速設定完成後。
- 原廠搭配的高性能空氣濾清器，建議您於使用前於濾清器上塗抹適量濾清器專用油，可加強過濾粉塵，避免進入化油器造成引擎損壞。
- 最後確認固定濾清器之束帶是否確實綁緊。

引擎請勿於未安裝空氣濾清器情況下運轉，並且注意濾清器的清潔工作，以避免造成引擎的損壞與壽命簡短。建議使用適當的濾清器專用油，強化過濾的功能。

## 10 FUELLING 燃油的添加



- Remove the cap from fuel bottle nozzle.
- Squeeze the fuel bottle, insert into fuel, and draw fuel into the fuel bottle. The fuel used should be methanol based model engine glow fuel (available at hobby shops) with 10% to 30% nitro content and 5% to 18% castor/synthetic oil content for lubrication.
- Fill car's fuel tank with glow fuel.

- 移開注油器上之封蓋。
- 擠壓注油器將桶裝燃油吸入注油器內。
- 打開油箱上蓋，擠壓注油器將燃油注入油箱內。

## 11 PREPARING THE ENGINE FOR STARTING 引擎整備工作

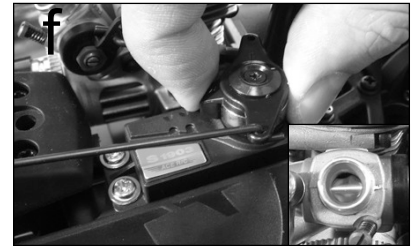
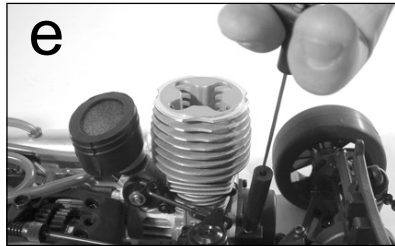
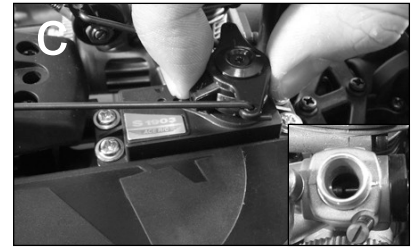
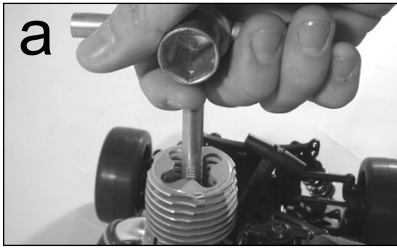

- To start an engine, first remove the glow plug with the included wrench.
- Check the glow plug by plugging it into the glow plug igniter. The glow plug element should light up brightly. If it lights up dimly, then the glow plug igniter is low (and it needs recharging). If it doesn't light up, or the plug element looks distorted, then the glow plug is bad (replace with new one). After checking, reinstall the glow plug.

The glow plug used for this engine can be: Thunder Tiger 9281, McCoy #9 / #59, Novarossi C4S / C5S / C6S, OS #8 / #A3 / #A5, and Picco P6S / P7S.

- With the radio off, manually turn the servo to open the carburetor (open throttle).
- Plug the tuned pipe exhaust tip.
- Keeping the exhaust tip plugged, pull on the engine's starter. Keep doing it until fuel reaches engine's carburetor, then pull it 3 more times to prime the engine.
- Manually return the servo back to neutral.

- 首次啟動引擎前，請使用扳手將火星塞卸下。
- 將火星塞塞入電夾內檢查，若火星塞呈現明亮、紅熱的現象表示正常，若火星塞無法正常點火，請將電夾充飽電再檢查一次；如果仍無法正常點火，請更換電夾或火星塞，再檢查一次。確認無誤後，將火星塞裝回引擎。

本引擎可適用於下列火星塞：雷虎No.9281, McCoy #9 / #59, Novarossi C4S / C5S / C6S, OS #8 / #A3 / #A5, and Picco P6S / P7S.

- 關掉遙控器電源，用手移動油門伺服器片，打開化油器節氣閥。
- 塞住加速管排氣口。
- 拉手拉器3~4次，將燃油自油箱吸到化油器裡。
- 用手移動油門伺服器片，關閉化油器節氣閥。

# 12 STARTING THE ENGINE 發動引擎



- Turn on the radio (transmitter first, then receiver).
- Clip the glow plug igniter onto engine's glow plug.
- Pull on the engine starter, release, repeat until the engine starts. Throttle maybe required to be opened momentarily, but release back to neutral immediately after it starts.

Remove the glow plug igniter from engine after engine has started and warmed up. If the engine stops right after the igniter is removed, the carburetor setting is too rich. Please refer to engine setting section.

If engine starter becomes hard to pull, the engine maybe flooded. To unflood an engine, remove the glow plug from engine, flip the car upside down, and pull on the starter to release excess fuel. Then, reinstall the glow plug and repeat the engine starting procedure.

- 打開遙控器電源(先打開發射機電源，再開接收機電源)。
- 將電夾接上引擎的火星塞。
- 拉動手拉器啟動引擎。油門微調可稍微提高一些，方便引擎的啟動。注意：手拉器拉出之長度必須保持在20~35公分之內，不可超過35公分，避免將手拉器繩索拉出過長，造成損壞。

當引擎發動達到工作溫度後，將電夾移開。假如引擎立刻熄火，表示引擎設定過於富油，請參考引擎設定單元，調整出最佳設定。假如引擎很難拉動，甚至拉不動，表示引擎已呈現積油狀態，請先將火星塞拆下，拉動手拉器數次，排油後裝回火星塞，重新啟動引擎。

# 13 SHOCK ADJUSTMENT 避震器懸吊調整

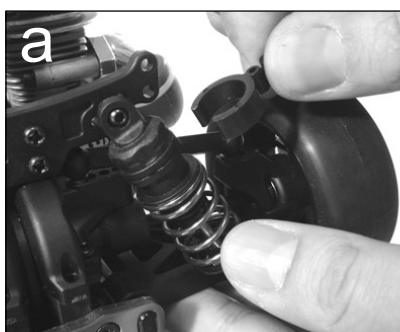

- Use the included shock clips to adjust for spring pre-load. Pressing the entire car down, release, and the car should return to ride height (indicated on set-up page). More pre-load clips will produce higher ride height, and less clips will produce lower ride height. Amount of clips used to front and rear shocks can be different, but clips should be the same for the left and right.
- a. 使用內附的調整環，調整車身高度。將車身下壓觸地後放開，如太低則增加調整環，如太高則減少調整環。一般調整至下擺臂呈水平狀態即可，更詳細的調整方式請參考設定表。

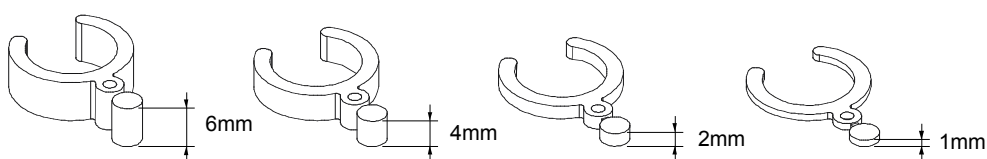

Hard Suspension  
懸吊較硬



Soft Suspension  
懸吊較軟

## 14 ENGINE BREAK-IN 引擎磨合

For a new engine (break-in setting), the high speed needle needs to be set as rich as possible. Turn the high speed needle 1/4 turn counterclockwise from initial setting (3~3.5 turns from fully closed). Repeat step 14b. Keep doing this until the engine stalls at full throttle, then turn the high speed needle 1/4 turn clockwise. Run the car in an open parking lot with this rich engine setting for at least 5 tanks of fuel to complete the break-in process. It is normal for new engines to stall many times during this time due to the rich setting. When it does, just restart the engine. After break-in, follow the engine setting procedure to set the carburetor for normal operations.

磨合新引擎時，需將高速油針盡可能設定在富油的狀態。從原廠設定好之高速油針位置（約3~3.5圈），每次逆時針退出1/4圈（全油門狀態下），直到引擎因富油而熄火；再將高速油針順時針轉進1/4圈。重新發動引擎，並保持此設定下（富油、全油門狀態下），磨合引擎約5桶油（車上之油箱），完成引擎磨合工作（引擎進行磨合時，因油針設定較為富油，常常會發生引擎熄火的正常現象，重新發動引擎即可）。

完成引擎磨合工作後，請參照下述引擎設定步驟，設定您愛車的引擎。

## ENGINE SETTING 引擎設定

Due to different fuel formula, operating elevation, humidity . . . etc. The engine may / may not operate properly at initial setting. Please follow the following procedure to achieve proper carburetor setting. Do not perform this procedure until the engine has been properly broken in.

- a. Start the engine.
- b. With a running engine, run the car back and forth in a straight line (full throttle achieved during each passage) in an open parking lot. Repeat, and note the sound of the exhaust. Do not hold the throttle open with car off the ground or the engine connect rod may break.
- c. If the exhaust does not reach a high pitch note, turn the high speed needle (long needle, extending from carburetor, pointing up) 1/4 turn clockwise, and repeat step 14b.  
If the exhaust reaches a high pitch note immediately, turn the high speed needle 1/4 turn counterclockwise, and repeat step 16b.
- d. Repeat step 14c until the engine reaches optimum setting (turning in the high speed needle will no longer have an effect at full throttle and turning out the needle will cause the engine's full throttle rpm to drop a little).  
For normal operations, turn the high speed needle 1/4 turn counterclockwise from the optimum high speed needle setting.
- e. To set the idle, turn the idle screw in (higher rpm) or out (lower rpm).  
Basically, the idle needs to be set at the lowest possible point before the engine stalls.
- f. To set the low speed needle (larger needle on the side of carburetor body), the engine needs to be broken-in and high speed needle needs to be set first.
- g. Repeating step 14b every 10 seconds (1 second of full throttle and 10 seconds of idle). If the engine rpm at idle drops after a few seconds and stalls, then turn in the low speed needle (clockwise) 1/4 turn. If the engine rpm stays the same or goes up at idle, then turn out the low speed needle (counterclockwise) 1/4 turn.
- h. Keep repeating step 14g until the engine rpm drops (goes to idle rpm, then drops a few more rpm after a few seconds) but does not stall at idle.

引擎因使用之燃油配方不同、操作習慣、氣候等影響，必須適時調整設定化油氣器，以保持引擎正常運作。  
注意：引擎設定工作開始前，必需完成引擎磨合工作。

- a. 發動引擎
- b. 於空曠安全的場地，重複進行直線來回的動作（適時將油門全開），調整高速（主）油針，並注意排氣管聲浪的變化。當車子在瞬間離地的狀態時，油門需放開，否則容易損傷活塞連桿。
- c. 若無法達到高速行走，請每次順時針轉進高速（主）油針1/8~1/4圈，再重複14b步驟。若引擎已達到高速行走，而產生吸不到油汽的間斷現象，請每次逆時針退出高速（主）油針1/8~1/4圈，再重複14b步驟。
- d. 重複步驟14b、14c完成高速（主）油針最佳設定（順時針旋轉主油針，引擎轉速反應會提高，逆時針旋轉主油針，引擎轉速少許降低）。在一般情況下使用引擎，請將高速（主）油針從最佳設定點退出1/4圈，可提高引擎使用壽命。
- e. 設定怠速時，請利用怠速螺絲設定，順時針轉進為提高怠速，逆時針轉出為降低怠速。在引擎不熄火狀態下，儘可能將引擎怠速設定在最低點（不熄火）。
- f. 設定低速（副）油針時，需完成引擎磨合以及高速油針設定後進行。
- g. 重複步驟14b每十秒鐘一個循環（一秒全油門、10秒怠速）。若引擎於怠速時轉速下降並熄火，順時針旋轉低速油針1/8圈；若引擎於怠速時轉速上升且偏高，逆時針旋轉低速油針1/8圈。
- h. 重複步驟14g，設定低速（副）油針及引擎正常怠速運作時之最低轉速（不熄火）。

# 15 STOPPING ENGINE 停止引擎

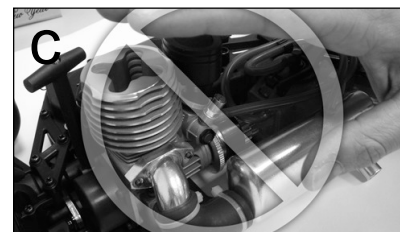
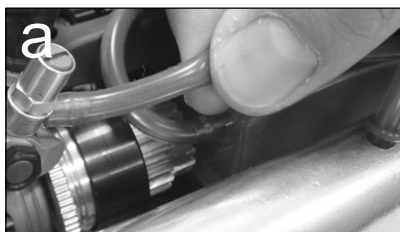

- a. Pinch fuel tube to stop fuel flow.
- b. After stopping the engine, turn off the receiver switch first, then the transmitter.
- c. Be careful! The engine and muffler will be getting extremely hot during operation! Don't touch them during or just after operation.
- a. 用手捏住輸油管使燃料無法輸送直到引擎停止。
- b. 引擎停止後先關掉接收機電源，然後再關發射機電源。
- c. 請注意！引擎及排氣管在運轉時或剛運轉後將處於高熱狀態，請勿徒手碰觸。

# 16 WHEEL AND TIRE PREPARATION 輪胎及輪轂



- a. Remove wheel cap screw using equipped 3mm hex wrench and detach wheels.
- b. Replace fresh tires and wheels if the original tires worn out seriously.
- c. Tighten the wheel cap screw down with the washer.
- a. 使用內附之六角板手將輪轂上六角固定螺絲取下。
- b. 將已磨損嚴重之輪胎組取下後換上新的輪胎組。
- c. 將六角固定螺絲及墊片重新鎖緊。

# 17 STORING AND MAINTENANCE 儲存及保養

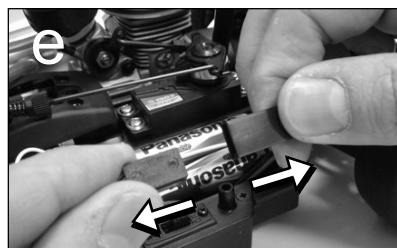
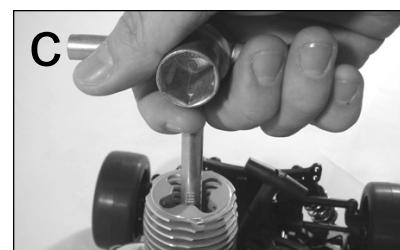
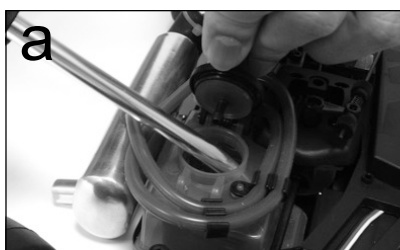

- a. Before storing you car, draw out any fuel from the tank.
- b. Next, restart the engine to combust remaining fuel.
- c. Unplug the glow plug and put after engine oil inside the engine, re-plug the glow plug.
- d. Wipe off the dirt and oil on your car.
- e. Make sure you have disconnected the power (batteries).
- a. 遙控車長時間不使用時請先使用注油壺將燃油吸乾。
- b. 然後重新發動引擎將引擎內剩餘燃油完全燃燒。
- c. 將火星塞取下並使用引擎潤滑油保養引擎內活塞，重新裝上火星塞。
- d. 清除車體及車殼上之油污。
- e. 再次確認電源線（電池）處於非連結狀態。

## 18 TWO-SPEED ADJUSTMENT 兩段變速之調整

**⚠ SKIP IF 2-SPEED NOT EQUIPPED**  
如購買型號未安裝二段變速，請跳過此篇調整。

- Your car's two-speed shift point is preset at factory. It should shift into 2nd gear within 16-19 feet (5-6m) on a full-throttle, standing-start acceleration.
  - If the shift point needs to be re-adjusted, please shut down the engine. First align the BLACK adjustment set screw with the opening on the 2nd gear as shown on the diagram.
  - Using a 2mm Allen wrench, turn the black adjustment set screw clockwise to make the two-speed shift later; turn it counter-clockwise to make the two-speed shift earlier. Only use 1/4 turn increments whenever you adjust your two-speed. Do not screw out the black set screw too much or it may cause set screw and spring to fall out.
  - If it is screwed in or out too much, reset the black set screw as following. First, screw in the black set screw clockwise gently until it is fully compressed. Be careful not over-tighten the black set screw; otherwise the spring inside the shoes may be damaged. And then turn the black set screw counter-clockwise about 1 1/2 - 1 3/4 turns.
- 車上的換檔（變速）點在出廠時即已預先調整。油門全開時，在16-19英尺（5-6公尺）內會轉入第二段齒輪然後開始加速。
  - 如果變速點需要調整時，引擎請先熄火。首先，打開第二段齒輪校準黑色調整螺絲，如圖示。
  - 以2mm的L形內六角扳手轉動黑色調整螺絲：順時鐘方向轉動讓2段變速的換檔時間晚些；逆時鐘方向轉動則會提早2段變速的換檔時間。每次調整兩段變速時，扳手轉動角度為90度。若轉動的角度過大，調整螺絲及彈簧可能會因而掉落。
  - 重新安裝調整螺絲及彈簧回復原廠設定值：首先，順時鐘方向慢慢的將調整螺絲鎖入直到完全鎖緊。請注意別將調整螺絲鎖入過緊，否則護套內的彈簧可能會因此受損。然後逆時鐘方向將黑色調整螺絲轉約1 1/2 - 1 3/4圈。

BLACK adjustment screw  
黑色調整螺絲

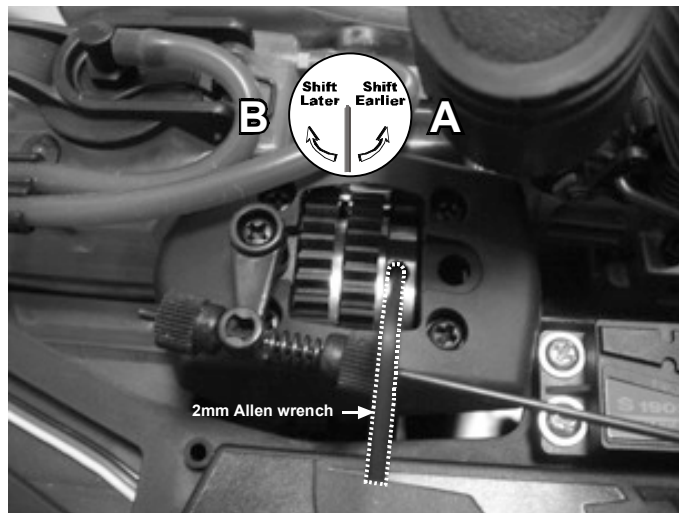
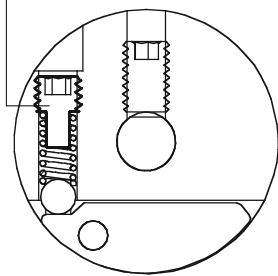

A. Shift timing becomes quicker.  
Shifts at lower RPM

B. Shift timing becomes slower.  
Shifts at higher RPM

A. 在低轉速時換檔，轉換時間變快  
B. 在高轉速時換檔，轉換時間變慢

Picture shows 6194-F TOMAHAWK VX 2-SPEED TRANSMISSION  
展示圖片為6194-F TOMAHAWK VX之二段變速。

## 19 BODY CUTTING 車殼剪裁

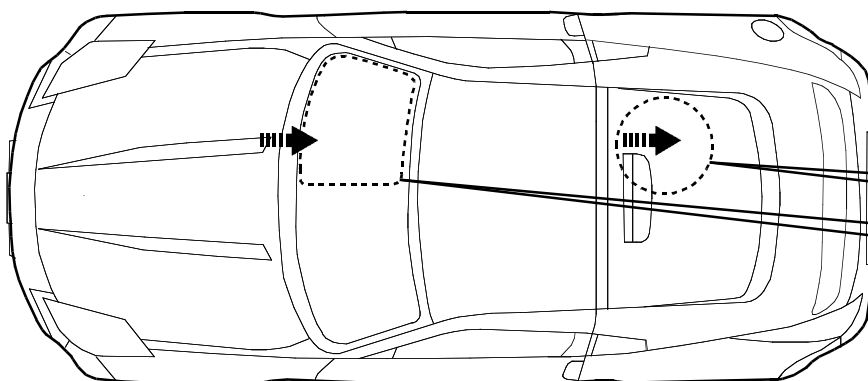

It is recommended to cut the window opening out to let cool air in for good circulation.

將車殼剪裁剪讓空氣流通，幫助引擎散熱。

# 20 DRIVING TIPS 駕駛的小技巧

a. Hold your elbows in and keep the transmitter antenna pointing straight up.

a. 手持發射機時請將雙肘靠緊身體並保持發射機天線朝上。

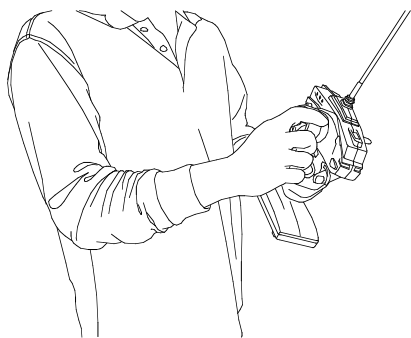

b. Squeeze the throttle trigger or pull the throttle stick gently and steer the car to left and right.

b. 開始操控前按扣油門板機(油門拉桿)時請緩慢增加油門並試著熟悉前輪轉向操作。



c. Squeeze the throttle trigger and release. Repeat this action to control car speed.

c. 初學者請先熟悉油門操控再慢慢加快車子行進速度。

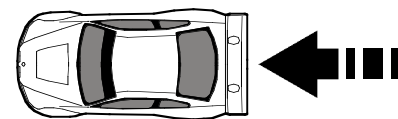
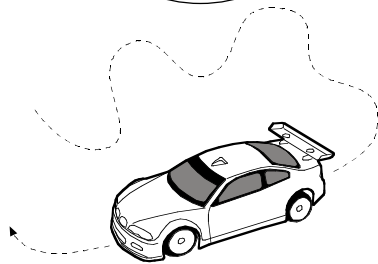
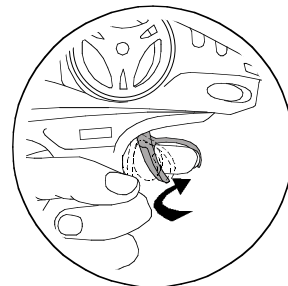

d. If you are of unsure of the steering direction, practice with the transmitter facing towards you.

d. 假設你不確定發射機的轉向，將發射機轉輪面向自己，先熟悉左右轉向。

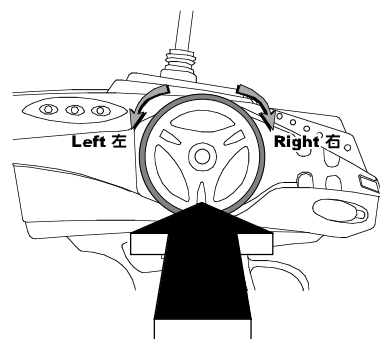

e. At first, set the steering D/R function for less steering response.

e. 初學者可參考發射機說明書調整D/R功能，以避免轉向太過靈活不易操控。

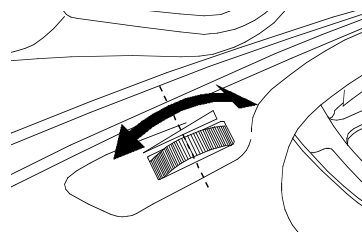

f. Be careful not to squeeze the throttle trigger abruptly while steering.

f. 轉向時請勿將油門全開以避免速度過快導致失控翻覆。

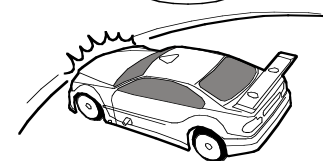
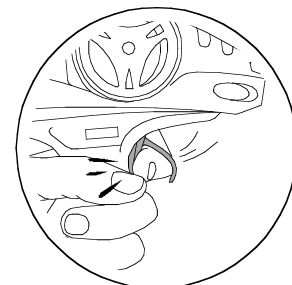

g. After you become used to the controls, experiment with high performance possible at full throttle and full steering.

g. 熟悉前述基本操控後再試著將油門全開進行高速操控。

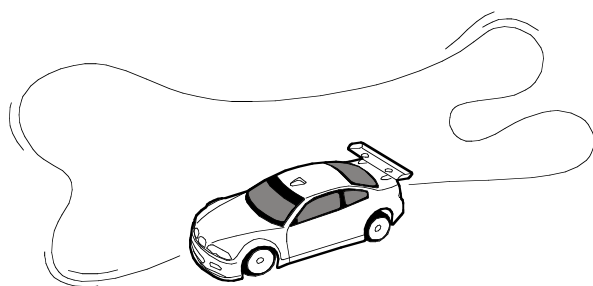

h. Practice doing figure 8S.

h. 建議可以使用繞8字來熟悉發射機操控動作。

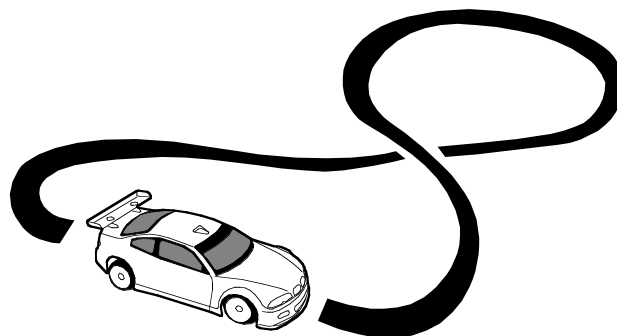



## TROUBLESHOOTING 常見問題與解決辦法

If you have trouble starting or keeping your TOMAHAWK VX/MX running, here's a quick checklist of what to look for first.  
 如果您的 TOMAHAWK VX/MX 有引擎及行駛上的問題，您可以參考下表的說明。如果問題無法解決，請與原購買經銷商聯絡。

Description 問題	Problem 可能原因	Solution 解決方法
Engine will not start 引擎無法啟動	Out of fuel 油箱沒油 .....	Fill fuel tank 加油
	Contaminated fuel 燃油過期 .....	Replace fuel 更換新油
	Glow plug igniter not charged 電夾沒電 .....	Charge glow igniter 請將電夾充電
	Glow plug bad 火星塞故障 .....	Replace glow plug, see "Glow Plug Problems" section below. 更換火星塞
	Fuel not getting to carburetor 燃油未進入化油器 .....	Open and close fuel tank lid twice. 塞住油箱回壓管，拉開並瞬間放開油箱上蓋幾次，將燃油壓進化油器
	Engine flooded 引擎積油 .....	See "Flooding" section below. 將火星塞拆開，進行排油步驟後，再裝回引擎，重新發動
	Engine overheating 引擎過熱.....	Allow engine to cool, richen fuel mixture, see "Fuel Mixture" section below 待引擎冷卻後，重新調整引擎至富油狀態
	Carburetor incorrectly adjusted 化油器調整不當.....	Re-adjust carburetor, see "Fuel Mixture" or "Factory Carburetor Settings" section below. 重新調整引擎，參考引擎調整步驟
	Exhaust blocked 排氣不順暢 .....	Check exhaust, remove blockage. 檢查排氣系統，將阻塞物移除
Air cleaner blocked 空氣濾清器阻塞 .....	Check air cleaner, remove blockage. 清洗或更換空氣濾棉	
Engine starts, then stalls 引擎容易熄火	Idle speed set to low 怠速太低.....	Adjust idle speed screw, see "Fuel Mixture" section below. 將怠速調高
	Air bubbles in fuel line 油管有空氣跑入.....	Check for leaks in fuel line 檢查漏氣部位予以更換
	Glow plug is fouled 火星塞效率不佳.....	Replace glow plug, see "Glow Plug Problems" Section below. 更換火星塞
Starter rope will not pull 手拉器無法拉動	Engine is flooded 引擎積油.....	See "Flooding" section below. 將火星塞拆開，進行排油步驟後，再裝回引擎，重新發動
	Engine is seized 引擎卡死.....	Examine engine for damage 詳細檢查引擎是否損壞



### Glow Plug Problems. 火星塞問題

The glow plug in your engine must be replaced periodically to maintain peak performance and easy starting. Most starting problems or erratic performance can be traced back to the glow plug. The easiest way to check for a faulty glow plug is to simply install a new one and see if the problem is corrected. However, to test the glow plug, remove the glow plug from the cylinder head with a 5/16" nut driver (make sure there is no dirt on top of the head which could fall into the engine. Do not lose the copper gasket which seals the glow plug.) Connect the glow plug to the glow igniter. All of the coils should glow bright white. Sometimes, the first few coils will not glow, while the rest are bright orange. This indicates a bad glow plug or low igniter battery. Try recharging the igniter, or replacing the glow plug.



為維持引擎的性能及易於啟動，火星塞需定期更換。啟動困難及影響引擎性能的原因，大部分都是火星塞故障，最簡單的測試方法，就是更換新的火星塞試試看。火星塞的拆裝請使用8mm的套筒扳手(拆裝前請先確認火星塞孔周圍是乾淨的，火星塞墊片勿弄丟)。將火星塞接上電夾，所有的電熱絲應該呈現炙熱的狀態。若剛夾上電夾，前幾圈電熱絲未立刻呈現炙熱狀態，過一下子才呈現橘色亮光，這表示火星塞已故障了或電夾沒電了，請更換火星塞或將電夾充電。

### Flooding 引擎積油

Symptoms of a flooded engine include difficulty in starting, muffled sounds coming from the exhaust, pull starter won't operate, and excess fuel draining from the exhaust outlet. Remove the glow plug with a 5/16" nut driver and also remove the air cleaner. Turn the car upside down and pull the starter a couple of times to drain the excess fuel out of the engine and carburetor. Re-install the glow plug and try starting again.

如果出現以下狀況，表示引擎積油了：啟動困難、無排氣聲音、手拉器無法拉動、多餘未燃燒的燃油自排氣管排出。這時候需進行排油步驟，拆下火星塞及空氣濾清器，將車子側傾一邊，拉動手拉器幾下，將積油排出。最後，裝回火星塞及空氣濾清器，重新啟動。

### Fuel Mixture 燃油混合比

The fuel mixture is controlled by three different adjustments on the carburetor, and should come preset from the factory (see photos below). Your engine should start and run slightly rich with these settings (rich is good for break-in). **Tuning Tip:** Always make sure you can see some exhaust smoke coming out of the exhaust outlet during operation. This is a good sign that enough fuel is getting to the engine.

燃油混合比的調整，由化油器的三個部分所控制，原廠設定值請參考右圖所示。建議您的引擎設定值，可以此為基準再稍微富油一些，以維持引擎壽命。引擎調整小秘訣：永遠保持排氣管可看到白煙排出，這表示引擎是處於正常運轉的狀態，引擎可發揮其性能又可延長壽命。

### Factory Carburetor Settings. 原廠設定值

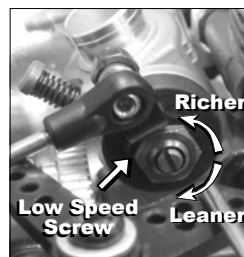

Low speed mixture  
6<sup>1</sup>/<sub>2</sub> turns out  
Clockwise=Leaner  
Counterclockwise-Richer

中低速混合比：  
6<sup>1</sup>/<sub>2</sub> 圈(鎖到底退回)  
順時針=貧油  
逆時針=富油

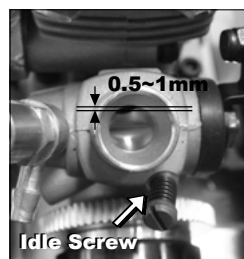

Idle speed:  
0.5~1mm)  
Adjust Idle Screw until  
0.5~1mm is obtained.

怠速：  
開口調整為0.5~1mm

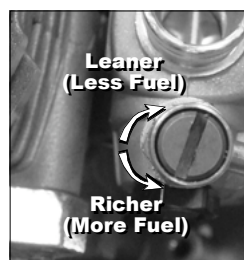

High speed mixture:  
3<sup>1</sup>/<sub>2</sub> turns out  
Clockwise = Leaner  
Counterclockwise-Richer

高速混合比：  
3<sup>1</sup>/<sub>2</sub> 圈(鎖到底退回)  
順時針=貧油  
逆時針=富油

NAME		TEMP		ENGINE		MUFFLER	
DATA		ST SERVO TYPE		HEAD CLEARANCE		FUEL TYPE	
TRACK		TH SERVO TYPE		PLUG NO.		RADIO	

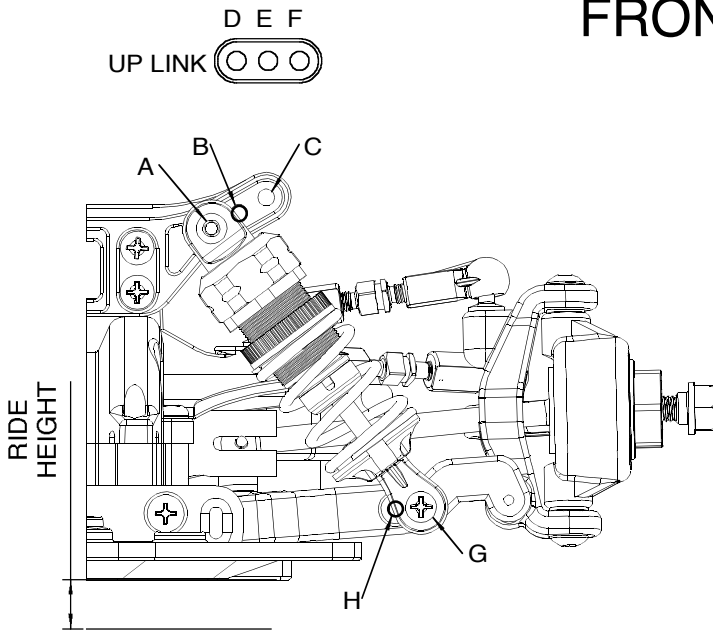

### FRONT

SHOCK OIL	
SHOCK PISTON	Ø1.2 Ø1.3 Ø1.4
SPRING	
SHOCK POSITION	A B C H G
CASTER ANGLE	
CAMBER ANGLE	
TOE IN	
TIRE TYPE	
TIRE HARDNESS	
TIRE DIAMETER	
RIDE HEIGHT	
LOWER ARM POSITION	⊙ ⊙ ⊙
UPPER ARM POSITION	D E F
SWAY BAR	
REAR DIFF	

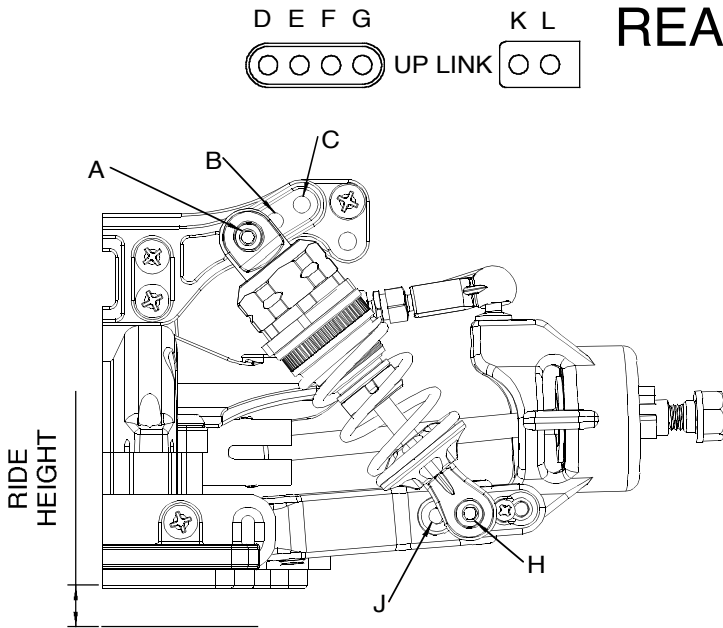

### REAR

SECOND SPEED SPRING	
SHOCK OIL	
SHOCK PISTON	Ø1.2 Ø1.3 Ø1.4
SPRING	
SHOCK POSITION	A B C J H
CASTER ANGLE	
CAMBER ANGLE	
TOE IN	
TIRE TYPE	
TIRE HARDNESS	
TIRE DIAMETER	
RIDE HEIGHT	
LOWER ARM POSITION	⊙ ⊙ ⊙
UPPER ARM POSITION	D E F G K L
SWAY BAR	
REAR DIFF	

CLUTCH TYPE		PINION (1)	t	PINION (2)	t
CLUTCH SPRING		SPUR (1)	t	SPUR (2)	t
DIFF RATE		TOTAL RATIO (1)		TOTAL RATIO (2)	

# ST-1

1/8<sup>th</sup> Nitro Powered 4WD

## STADIUM RACING TRUCK

No.6233-F



### Specifications

Length	11.8" (300mm)
Width	12" (305mm excl. tires)
Height	7.0" (178mm)
Wheelbase	11.75" - 14.37" (298mm - 365mm)
Wheel Track	11.2" - 14.37" (285mm - 365mm) (30mm)
Weight	6.04 lbs (2740g)



**2CH TRANSMITTER**  
Front Grip or Rear Stick For Choice

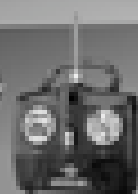

Thunder Tiger PRO-280X-R  
**PRO-280X-R 4.60CC**  
PULL-START NITRO ENGINE

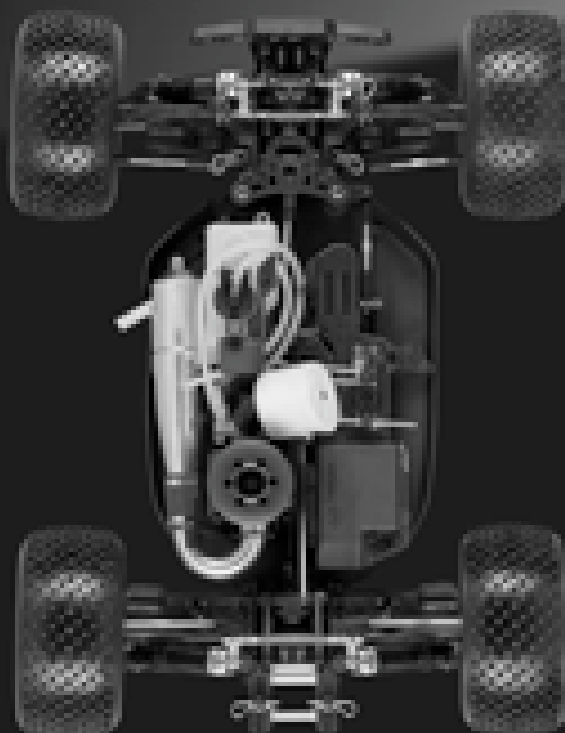

### FEATURES

- Powerful 4.60c.c. PRO-280X-R pull start engine with 2 needle slide carb.
- Ti color anodized radio tray and steering brace.
- Extra long and rigid suspension arms provide superior handling, and better cornering ability than other trucks.
- 3 sets of durable gear differentials.
- Eight-spoke chrome wheels & race ready high grip tires.
- Lowest C.G., provides stable handling and resists rollovers.
- Fully equipped C.V. driveshafts, front, rear and center.
- Enclosed radio box enables to install 5 aa size batteries.
- 150c.c. large capacity fuel tank with large fuel splash guard.
- 4 machined aluminum oil-filled shocks with 3.5mm shafts, maximum for 6 shocks installed possibly.
- Tuned pillow ball front susp. system for ease of camber tuning.
- Variable toe & squat blocks equipped.
- Aluminum tuned pipe & header.
- High torque 8.4g metal gear steering & Throttle/Brake servo included.
- Full set of ball bearings to keep drivetrain components spinning freely.
- Composite 3-shoe clutch.
- Dual oil-resistant fiber disc brakes.
- 3.5mm front/rear sway bar included.
- 17mm hex drives fit pro-line 40 series tires.

